

128-Channel Serial to Parallel Converter with Push-Pull Outputs

Features

- 128 High-Voltage Channels
 - Up to 80V Operating Output Voltage
 - 30 mA Peak Output Sink/Source Current
 - Output Diodes to Ground for Efficient Power Recovery
- Four Separate Shift Registers
 - Clockwise and Counter-Clockwise Data Shifting via DIR Pin
- 40 MHz Data Rate

Applications

- Inkjet Printer Driver
- Plasma Display Driver
- 3D Printer Driver

Related Devices

- **HV582:** 96-Channel Serial to Parallel Converter with Push-Pull Outputs

Description

HV583 is a unipolar, 128-channel low-voltage serial to high-voltage parallel converter with push-pull outputs. This device has been designed for applications requiring multiple high-voltage outputs with current sinking and sourcing capabilities, such as plasma displays and inkjet printers.

The device consists of four parallel 32-bit shift registers, a 128-bit latch and 128 high-voltage outputs. Data can be input at 40 MHz or up to 25 MHz when cascaded in a multiple device configuration.

HV583 is offered in a 169-ball 10 x 10 x 1.1 mm TFBGA package.

Package Type

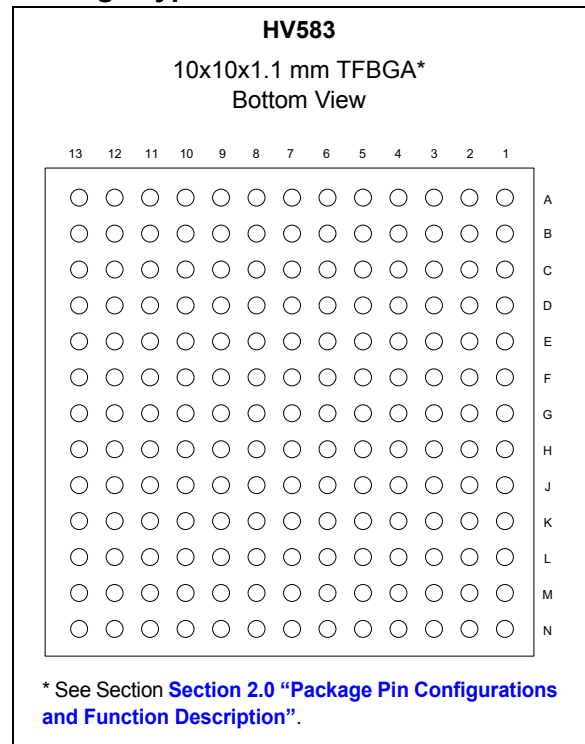

HV583

Block Diagram

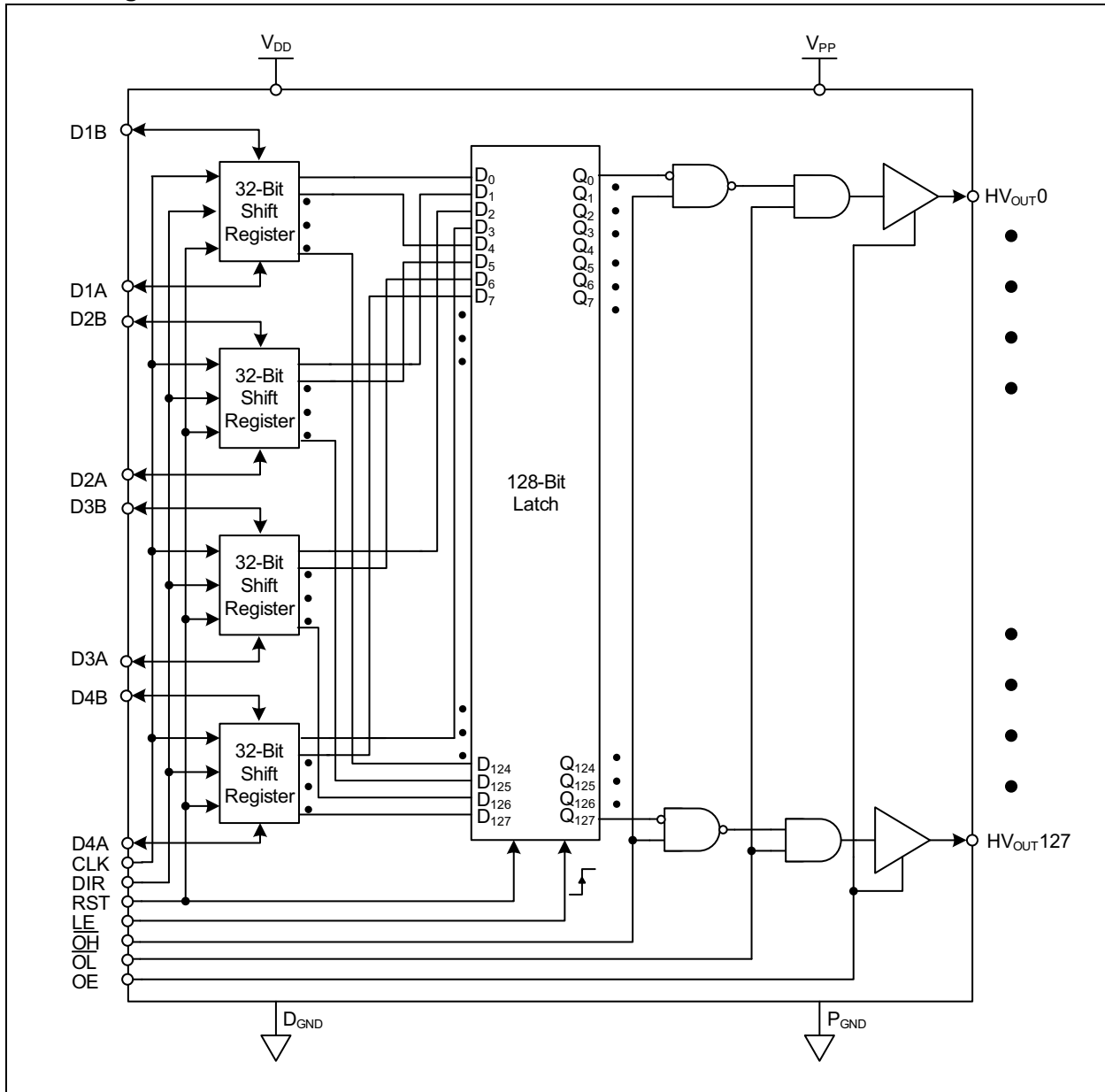

1.0 ELECTRICAL CHARACTERISTICS

Absolute Maximum Rating†

Supply Voltage V_{DD}	-0.5V to +6.5V
High-Voltage Supply V_{PP}	-0.5V to +90V
Output Sink and Source Current I_{OUT}	-65 mA to +40 mA
Output Body Diode Current I_{DIODE}	-65 mA to +65 mA
Logic Input Voltage.....	-0.5V to V_{DD} +0.5V
Operating Junction Temperature.....	-25°C to +125°C
Storage Temperature	-40°C to +150°C

†**Notice:** Stresses above those listed under “Absolute Maximum Ratings” may cause permanent damage to the device. This is a stress rating only and functional operation of the device at those or any other conditions above those indicated in the operational listings of this specification is not implied. Exposure to maximum rating conditions for extended periods may affect device reliability. Device is ESD sensitive. Use appropriate ESD precautions.

RECOMMENDED OPERATING CONDITIONS

Parameter	Symbol	Min.	Typ.	Max.	Units	Conditions
High-Voltage Supply	V_{PP}	15	-	80	V	
Low-Voltage Supply	V_{DD}	4.5	5.0	5.5	V	
HV _{OUT} Peak Output Current	I_{OUT}	-30	—	30	mA	
V_{PP} Power Supply Slew Rate	SR	-	—	8.0	V/μs	
Clock Frequency	f_{CLK}	-	—	40	MHz	Data Read
		-	—	25	MHz	Cascaded Devices

TABLE 1-1: POWER SEQUENCES

Sequence Type	Steps
Power-Up Sequence	<ol style="list-style-type: none"> 1. Connect ground. 2. Apply V_{DD}. 3. Set all inputs (data, CLK, etc.) to a known state. 4. Apply V_{PP}.
Power-Down Sequence	Repeat the power-up sequence in reverse order.

DC ELECTRICAL CHARACTERISTICS

Electrical specifications: Unless otherwise specified, $T_A = T_J = +25^\circ\text{C}$, $V_{DD} = 5.0\text{V}$ and $V_{PP} = 80\text{V}$.

Parameter	Symbol	Min.	Typ.	Max.	Units	Conditions
V_{PP} Quiescent Supply Current	I_{PPQ}	—	—	10	μA	
V_{DD} Quiescent Supply Current	I_{DDQ}	—	—	10	μA	
High-Level Output Voltage	HV_{OH}	73	76	—	V	$I_{OUT} = 15\text{ mA}$, $V_{PP} = 80\text{V}$
		10	—	—		$I_{OUT} = 10\text{ mA}$, $V_{PP} = 20\text{V}$
Output P-Channel Body Diode	HV_{OHD}	—	—	81.5	V	$I_{OUT} = -30\text{ mA}$, $V_{PP} = 80\text{V}$ (Note 1)
Low-Level Output Voltage	HV_{OL}	—	3.0	6.0	V	$I_{OUT} = -15\text{ mA}$
Output N-Channel Body Diode	HV_{OLD}	-1.5	—	—	V	$I_{OUT} = 30\text{ mA}$ (Note 1)

Note 1: Specification is for design guidance only.

HV583

DC ELECTRICAL CHARACTERISTICS (CONTINUED)

Electrical specifications: Unless otherwise specified, $T_A = T_J = +25^\circ\text{C}$, $V_{DD} = 5.0\text{V}$ and $V_{PP} = 80\text{V}$.						
Parameter	Symbol	Min.	Typ.	Max.	Units	Conditions
Logic Input High Voltage	V_{IH}	2.3	—	V_{DD}	V	$V_{DD} = 4.5\text{V to } 5.5\text{V}$
Logic Input Low Voltage	V_{IL}	0	—	0.7		$V_{DD} = 4.5\text{V to } 5.5\text{V}$
Logic Input High Current	I_{IH}	—	—	1.0	μA	$V_{IH} = 5.3\text{V}$, $V_{DD} = 5.0\text{V}$
		10	30	60		$V_{IH} = 5.0\text{V}$, for DIR only
Logic Input Low Current	I_{IL}	-1.0	—	—		$V_{IL} = -0.3\text{V}$
Logic Output High	V_{OH}	4.5	—	—	V	$I_{OUT} = 1.0\text{ mA}$
Logic Output Low	V_{OL}	—	—	0.5		$I_{OUT} = -1.0\text{ mA}$

Note 1: Specification is for design guidance only.

AC ELECTRICAL CHARACTERISTICS

Electrical specifications: Unless otherwise specified $T_A = T_J = 25^\circ\text{C}$, $V_{DD} = 5.0\text{V}$ and $V_{PP} = 80\text{V}$							
Parameter	Symbol	Min.	Typ.	Max.	Units	Conditions	
Clock Pulse Width, High and Low ⁽¹⁾	t_{wCLK}	10	—	—	ns	$V_{DD} = 4.5\text{V to } 5.5\text{V}$ $T_J = -25^\circ\text{C to } +125^\circ\text{C}$	
LE Pulse Width, High and Low ⁽²⁾	t_{wLE}	10	—	—			
Setup Time, DnA/B to CLK ⁽¹⁾	t_{su1}	5	—	—			
Setup Time, CLK to LE ⁽¹⁾	t_{su2}	10	—	—			
Setup Time, LE to $\overline{\text{OL}}$, $\overline{\text{OH}}$ ⁽¹⁾	t_{su3}	25	—	—			
Setup Time, RST to CLK ⁽²⁾	t_{su4}	5	—	—			
Setup Time, RST to LE ⁽²⁾	t_{su5}	5	—	—			
Hold Time, CLK to DnA/B ⁽¹⁾	t_{h1}	5	—	—			
Hold Time, LE to CLK ⁽¹⁾	t_{h2}	10	—	—			
Hold Time, CLK to RST ⁽²⁾	t_{h3}	5	—	—			
Hold Time, LE to RST ⁽²⁾	t_{h4}	5	—	—			
CLK to DnA/B (High-to-Low)	t_{pdHL}	—	—	25			$C_L = 15\text{ pF}$
CLK to DnA/B (Low-to-High)	t_{pdLH}	—	—	25			$C_L = 15\text{ pF}$
LE, $\overline{\text{OL}}$, $\overline{\text{OH}}$ to HV_{OUTn} (High-to-Low)	t_{pHL}	—	—	150			$C_L = 50\text{ pF}$
LE, $\overline{\text{OL}}$, $\overline{\text{OH}}$ to HV_{OUTn} (Low-to-High)	t_{pLH}	Typ-40	$t_{pHL} + t_f$	Typ+40	$C_L = 80\text{ pF}$		
OE to HV_{OUTn} (High-to-Low)	t_{pHZL}	—	—	150	$C_L = 50\text{ pF}$		
OE to HV_{OUTn} (Low-to-High)	t_{pLZH}	Typ-40	$t_{pHL} + t_f$	Typ+40	$C_L = 80\text{ pF}$		
OE to HV_{OUTn} (High-to-Low)	t_{pHZ}	—	—	300	$R_L = 10\text{K}$, $C_L = 50\text{ pF}$		
OE to HV_{OUTn} (Low-to-High)	t_{pLZ}	—	—	300	$R_L = 10\text{K}$, $C_L = 50\text{ pF}$		
Rise Time HV_{OUTn}	t_r	—	—	120	$C_L = 50\text{ pF}$		
Fall Time HV_{OUTn}	t_f	—	—	120	$C_L = 50\text{ pF}$		

Note 1: Specification is obtained by characterization and is not 100% tested.

Note 2: Specification is for design guidance only.





TEMPERATURE SPECIFICATIONS

Parameters	Sym.	Min.	Typ.	Max.	Units	Conditions
Temperature Ranges						
Operating Junction Temperature	T_J	-25	—	+125	°C	
Storage Temperature	T_A	-40	—	+150	°C	
Package Thermal Resistance						
Thermal Resistance, 169-Ball TFBGA	θ_{JA}	—	27	—	°C/W	

HV583

1.1 Logic Characteristics

TABLE 1-2: SHIFT REGISTER TRUTH TABLE

DIR	CLK	State	Direction
L or Open		Shift	DnB to DnA
L or Open		Hold	DnB to DnA
H		Shift	DnA to DnB
H		Hold	DnA to DnB

Legend:

D = Data

H = Level High

L = Level Low

X = Don't Care

Z = High Impedance

 = Low-to-High Transition

 = High-to-Low Transition

TABLE 1-3: LATCH TRUTH TABLE

LE	Output State of Latch
L to H	Latch Execution
H to L	Hold

TABLE 1-4: HV_{OUTn} TRUTH TABLE

OE	\overline{OL}	\overline{OH}	DnA/DnB	HV _{OUTn}
L	X	X	X	Z
H	L	X	X	L
H	H	L	X	H
H	H	H	L	L
H	H	H	H	H

TABLE 1-5: RESET TRUTH TABLE





RST	CLK	LE	Shift Register	Latches
0		X	Shift	X
0	X		X	Latch
1		X	Clear	X
1	X		X	Clear

TABLE 1-6: OUTPUT SHIFT OPERATION

Input	Output	DIR	Shift Operation
D1A = D	D1B	H	D to D124...D0 to D1B
D2A = D	D2B	H	D to D125...D1 to D2B
D3A = D	D3B	H	D to D126...D2 to D3B
D4A = D	D4B	H	D to D127...D3 to D4B
D1B = D	D1A	L or Open	D to D0...D124 to D1A
D2B = D	D2A	L or Open	D to D1...D125 to D2A
D3B = D	D3A	L or Open	D to D2....D126 to D3A
D4B = D	D4A	L or Open	D to D3....D127 to D4A

1.2 Timing Diagram

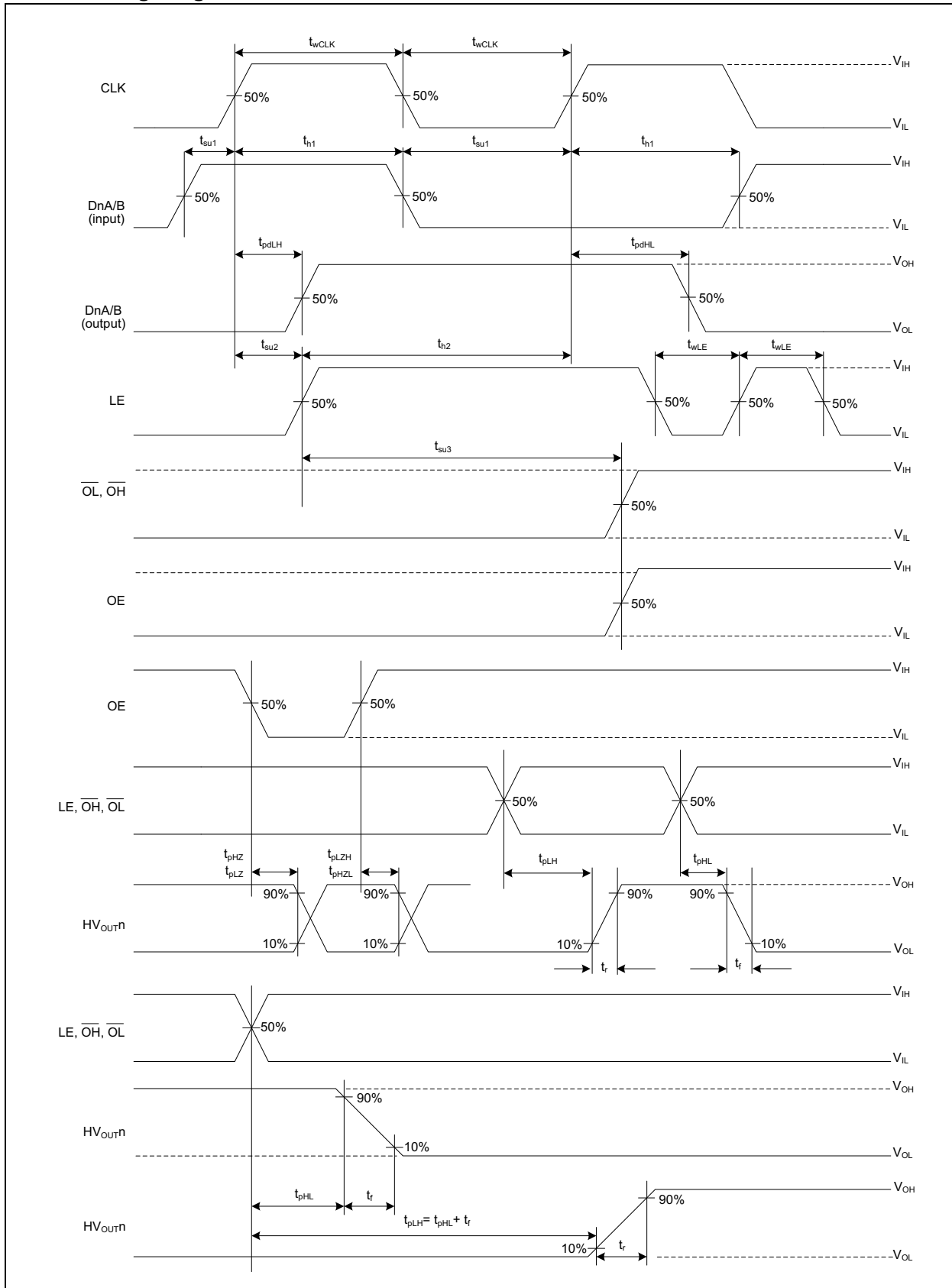

2.0 PACKAGE PIN CONFIGURATIONS AND FUNCTION DESCRIPTION

This section details the pin designation for the 169-Ball TFBGA package (Figure 2-1). The descriptions of the pins are listed in Table 2-1.

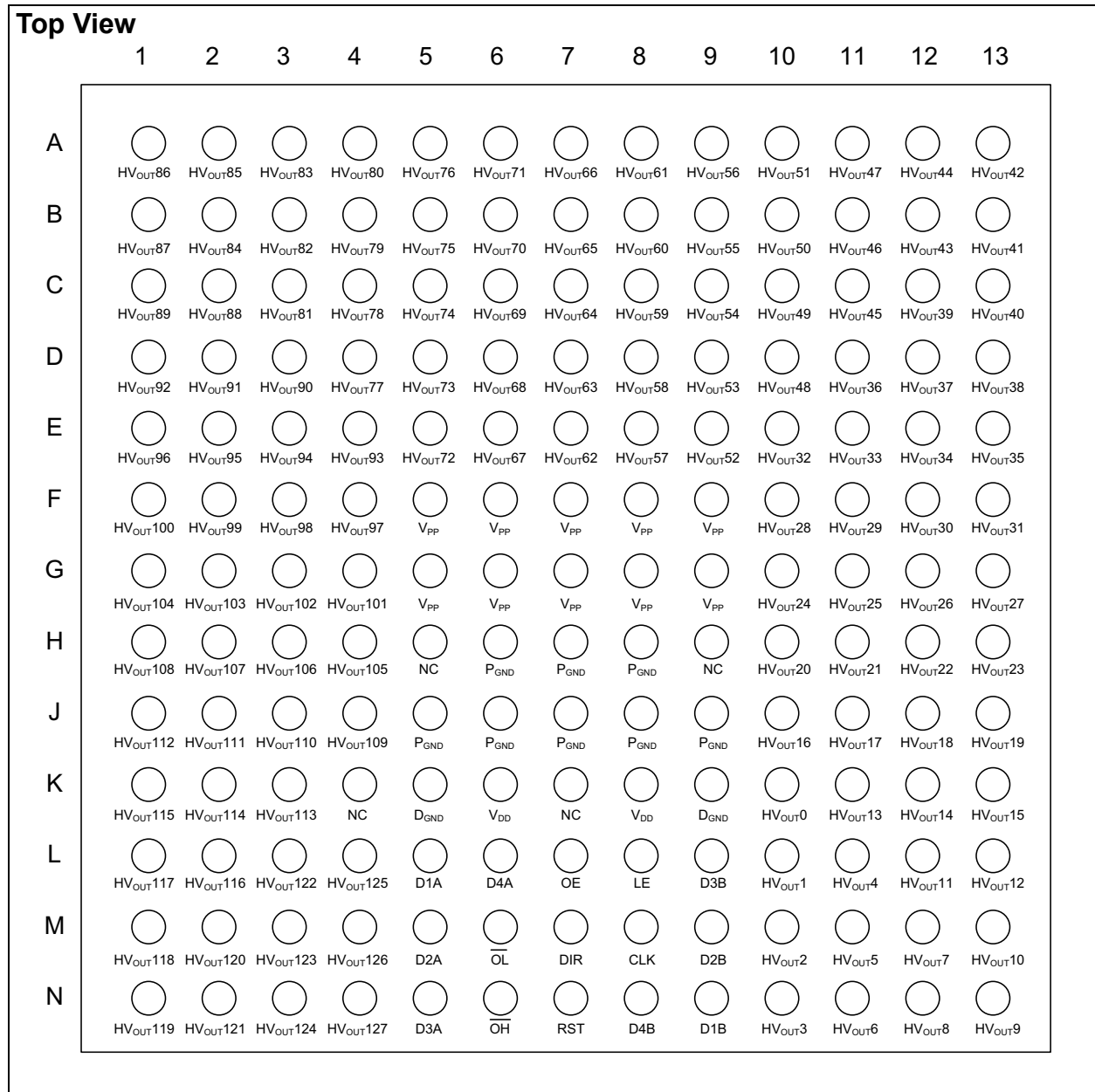

FIGURE 2-1: 169-Ball TFBGA Package.

HV583

TABLE 2-1: PIN ASSIGNMENT

Pin #	Name	Pin #	Name	Pin #	Name	Pin #	Name
A1	HV _{OUT} 86	D5	HV _{OUT} 73	H5, H9, K4, K7	NC	M8	CLK
A2	HV _{OUT} 85	D6	HV _{OUT} 68	H6, H7, H8, J5, J6, J7, J8, J9	P _{GND}	M9	D2B
A3	HV _{OUT} 83	D7	HV _{OUT} 63	H10	HV _{OUT} 20	M10	HV _{OUT} 2
A4	HV _{OUT} 80	D8	HV _{OUT} 58	H11	HV _{OUT} 21	M11	HV _{OUT} 5
A5	HV _{OUT} 76	D9	HV _{OUT} 53	H12	HV _{OUT} 22	M12	HV _{OUT} 7
A6	HV _{OUT} 71	D10	HV _{OUT} 48	H13	HV _{OUT} 23	M13	HV _{OUT} 10
A7	HV _{OUT} 66	D11	HV _{OUT} 36	J1	HV _{OUT} 112	N1	HV _{OUT} 119
A8	HV _{OUT} 61	D12	HV _{OUT} 37	J2	HV _{OUT} 111	N2	HV _{OUT} 121
A9	HV _{OUT} 56	D13	HV _{OUT} 38	J3	HV _{OUT} 110	N3	HV _{OUT} 124
A10	HV _{OUT} 51	E1	HV _{OUT} 96	J4	HV _{OUT} 109	N4	HV _{OUT} 127
A11	HV _{OUT} 47	E2	HV _{OUT} 95	J10	HV _{OUT} 16	N5	D3A
A12	HV _{OUT} 44	E3	HV _{OUT} 94	J11	HV _{OUT} 17	N6	$\overline{\text{OH}}$
A13	HV _{OUT} 42	E4	HV _{OUT} 93	J12	HV _{OUT} 18	N7	RST
B1	HV _{OUT} 87	E5	HV _{OUT} 72	J13	HV _{OUT} 19	N8	D4B
B2	HV _{OUT} 84	E6	HV _{OUT} 67	K1	HV _{OUT} 115	N9	D1B
B3	HV _{OUT} 82	E7	HV _{OUT} 62	K2	HV _{OUT} 114	N10	HV _{OUT} 3
B4	HV _{OUT} 79	E8	HV _{OUT} 57	K3	HV _{OUT} 113	N11	HV _{OUT} 6
B5	HV _{OUT} 75	E9	HV _{OUT} 52	K5, K9	D _{GND}	N12	HV _{OUT} 8
B6	HV _{OUT} 70	E10	HV _{OUT} 32	K6, K8	V _{DD}	N13	HV _{OUT} 9
B7	HV _{OUT} 65	E11	HV _{OUT} 33	K10	HV _{OUT} 0		
B8	HV _{OUT} 60	E12	HV _{OUT} 34	K11	HV _{OUT} 13		
B9	HV _{OUT} 55	E13	HV _{OUT} 35	K12	HV _{OUT} 14		
B10	HV _{OUT} 50	F1	HV _{OUT} 100	K13	HV _{OUT} 15		
B11	HV _{OUT} 46	F2	HV _{OUT} 99	L1	HV _{OUT} 117		
B12	HV _{OUT} 43	F3	HV _{OUT} 98	L2	HV _{OUT} 116		
B13	HV _{OUT} 41	F4	HV _{OUT} 97	L3	HV _{OUT} 122		
C1	HV _{OUT} 89	F5, F6, F7, F8, F9, G5, G6, G7, G8, G9	V _{PP}	L4	HV _{OUT} 125		
C2	HV _{OUT} 88	F10	HV _{OUT} 28	L5	D1A		
C3	HV _{OUT} 81	F11	HV _{OUT} 29	L6	D4A		
C4	HV _{OUT} 78	F12	HV _{OUT} 30	L7	OE		
C5	HV _{OUT} 74	F13	HV _{OUT} 31	L8	LE		
C6	HV _{OUT} 69	G1	HV _{OUT} 104	L9	D3B		
C7	HV _{OUT} 64	G2	HV _{OUT} 103	L10	HV _{OUT} N1		
C8	HV _{OUT} 59	G3	HV _{OUT} 102	L11	HV _{OUT} 4		
C9	HV _{OUT} 54	G4	HV _{OUT} 101	L12	HV _{OUT} 11		
C10	HV _{OUT} 49	G10	HV _{OUT} 24	L13	HV _{OUT} 12		
C11	HV _{OUT} 45	G11	HV _{OUT} 25	M1	HV _{OUT} 118		
C12	HV _{OUT} 39	G12	HV _{OUT} 26	M2	HV _{OUT} 120		
C13	HV _{OUT} 40	G13	HV _{OUT} 27	M3	HV _{OUT} 123		
D1	HV _{OUT} 92	H1	HV _{OUT} 108	M4	HV _{OUT} 126		
D2	HV _{OUT} 91	H2	HV _{OUT} 107	M5	D2A		
D3	HV _{OUT} 90	H3	HV _{OUT} 106	M6	$\overline{\text{OL}}$		
D4	HV _{OUT} 77	H4	HV _{OUT} 105	M7	DIR		

2.1 High-Voltage Output Pins (HV_{OUT0} to HV_{OUT127})

These are the high-voltage output channels (Push-Pull).

2.2 High-Voltage Power Supply Pins (V_{PP})

High-voltage power supply pins for the output channels (HV_{OUTn}).

2.3 No Connection Pins (NC)

NC pins do not have any functionality on the IC. These pins should not be connected.

2.4 High-Voltage Ground Pins (P_{GND})

High-voltage ground pins provide the reference ground level for the high-voltage output channels.

2.5 Digital Logic Ground Pins (D_{GND})

Digital Logic Ground pins provide a reference ground level for the low-voltage section of the IC, shift registers, latches and decoders.

2.6 Logic Power Supply Pins (V_{DD})

Logic power supply pins for the 32-bit shift registers, 128-bit latch and decoders.

2.7 Data Input/Output Pins (D1A, D2A, D3A, D4A)

Data Input/Output pins are configurable as inputs or outputs for the shift registers depending on the state of the Direction pin (DIR).

When DIR is High, pins D1A to D4A are configured as inputs to the data shift registers. When DIR is Low, these pins are configured as outputs of the data shift registers.

2.8 Output Enable Pin (OE)

The Output Enable pin controls the functionality of the high-voltage output channels.

When OE is High, all HV_{OUTn} channels are enabled and form a push-pull configuration to operate according to input data, \overline{OL} or \overline{OH} configuration states. When OE is Low, all HV_{OUTn} channels are forced to a high-impedance state, regardless of the data stored in the 128-bit latch or the state of the \overline{OL} and \overline{OH} pins.

2.9 Latch Enable Pin (LE)

The Latch Enable pin controls the data transfer from the input shift registers to the 128-bit latch and the HV_{OUTn} channels.

When LE transitions from Low to High (rising edge), data is transferred from the 128-bit data latch to the HV_{OUTn} output channels. When LE is Low, new data can be clocked into the shift registers.

2.10 Data Input/Output Pins (D1B, D2B, D3B, D4B)

Data Input/Output pins are configurable as inputs or outputs for the shift registers, depending on the state of the Direction pin (DIR).

When DIR is Low, pins D1B to D4B are configured as inputs to the data shift registers. When DIR is High, pins are configured as outputs of the data shift registers.

2.11 Output Low Pin (\overline{OL})

The Output Low pin sets all high-voltage output channels (HV_{OUT0} to HV_{OUT127}) to a Low-level state (P_{GND}).

When \overline{OL} is set Low and OE is High, all the HV_{OUTn} channels are forced to a Low-level state (P_{GND}), regardless of the data stored in the 128-bit latch.

2.12 Direction Pin (DIR)

The DIR pin controls the direction of the input data flow for the input registers, whether it is clockwise (DnB to DnA) or counter-clockwise (DnA to DnB).

When the DIR pin is set High, data flows from DnA to DnB. When DIR pin is set Low, data flows from DnB to DnA. See [Table 1-6](#) for more information.

2.13 Clock Input Pin (CLK)

This is the Clock Input pin for 32-bit input shift registers.

2.14 Output High Pin (\overline{OH})

The Output High pin sets all high-voltage output channels (HV_{OUT0} to HV_{OUT127}) to a High-level state (V_{PP}).

When \overline{OH} is Low while OE and \overline{OL} are High, all the HV_{OUTn} channels are forced to a High-level state (V_{PP}), regardless of the data stored in the 128-bit latch. See [Table 1-4](#) for more information.

2.15 Reset Pin (RST)

The RST pin clears shift registers and the 128-bit latch data content when it is set High during the rising edge of the CLK and LE, respectively. See [Table 1-5](#) for more information.

HV583

3.0 FUNCTIONAL DESCRIPTION

The HV583 is a unipolar, 128-channel, low-voltage serial to high-voltage parallel converter. The device consists of four parallel 32-bit shift registers, a 128-bit latch and 128 high-voltage outputs.

The four independent shift registers allow data to be updated into the 128-bit latch at four times the speed of a single register, providing a fast update rate for the 128 output channels. The 128-bit latch holds the data for the high-voltage output channels, whether it is a High-level or Low-level state. The flow of the input data can switch direction from clockwise (DnB to DnA) to counter-clockwise (DnA to DnB) by controlling the DIR pin. A reset pin (RST) is provided to clear the contents of the latches. All channels can be set at the same time to a high-impedance state (high Z), Low-level state, or High-level state through the OE, $\overline{\text{OL}}$ and $\overline{\text{OH}}$ pins, respectively.

The high-output voltages ($\text{HV}_{\text{OUT}n}$) can operate from 15V-80V with a maximum current source and sink capability of 30 mA.

3.1 Application Information

HV583 is designed for applications requiring multiple high-voltage outputs with current sinking and sourcing capabilities in the range of ± 30 mA. Typical applications where the HV583 is utilized are in plasma displays, Inkjet printer drivers and 3D printer drivers.

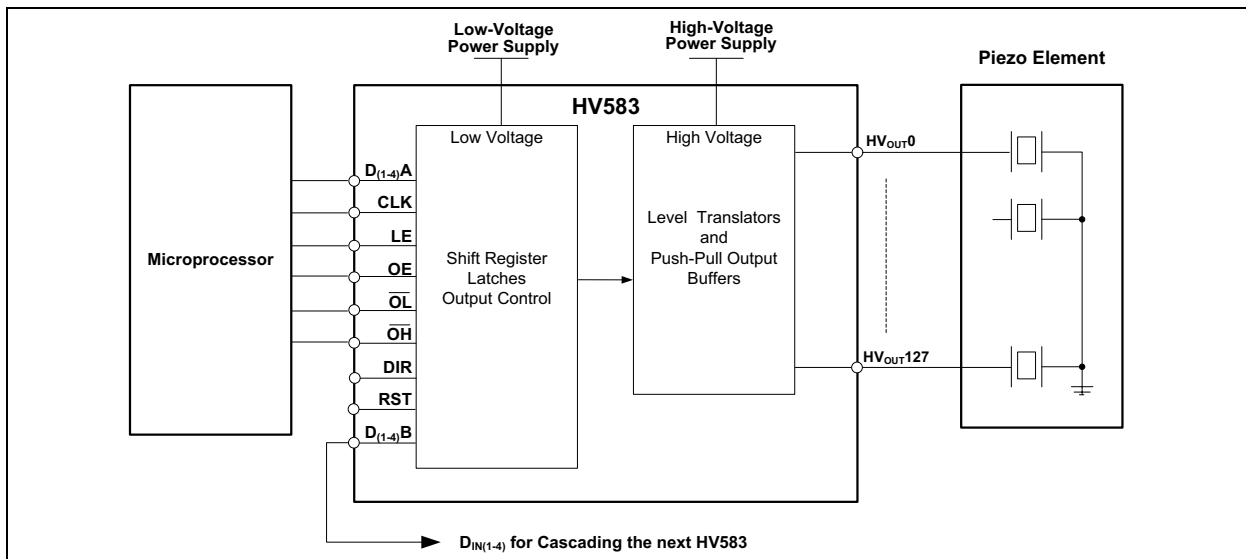

FIGURE 3-1: Typical Application Block Diagram.

4.0 PACKAGING INFORMATION

4.1 Package Marking Information

169-Ball TFBGA (10 x10 x1.1 mm)

Example

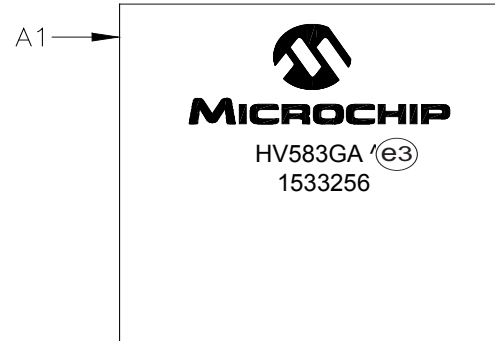
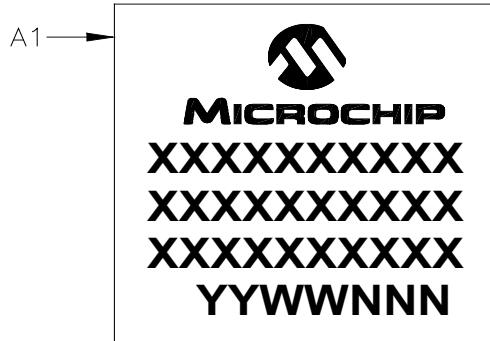

Legend:	XX...X	Product Code or Customer-specific information
	Y	Year code (last digit of calendar year)
	YY	Year code (last 2 digits of calendar year)
	WW	Week code (week of January 1 is week '01')
	NNN	Alphanumeric traceability code
	(e3)	Pb-free JEDEC designator for Matte Tin (Sn)
	*	This package is Pb-free. The Pb-free JEDEC designator (e3) can be found on the outer packaging for this package.

Note: In the event the full Microchip part number cannot be marked on one line, it will be carried over to the next line, thus limiting the number of available characters for customer-specific information. Package may or may not include the corporate logo.

HV583

169-Ball Thin Fine Pitch Ball Grid Array (7G) - 10x10x1.10 mm Body [TFBGA] (Complies with JEDEC Terminal Assignment recommendations)

Note: For the most current package drawings, please see the Microchip Packaging Specification located at <http://www.microchip.com/packaging>

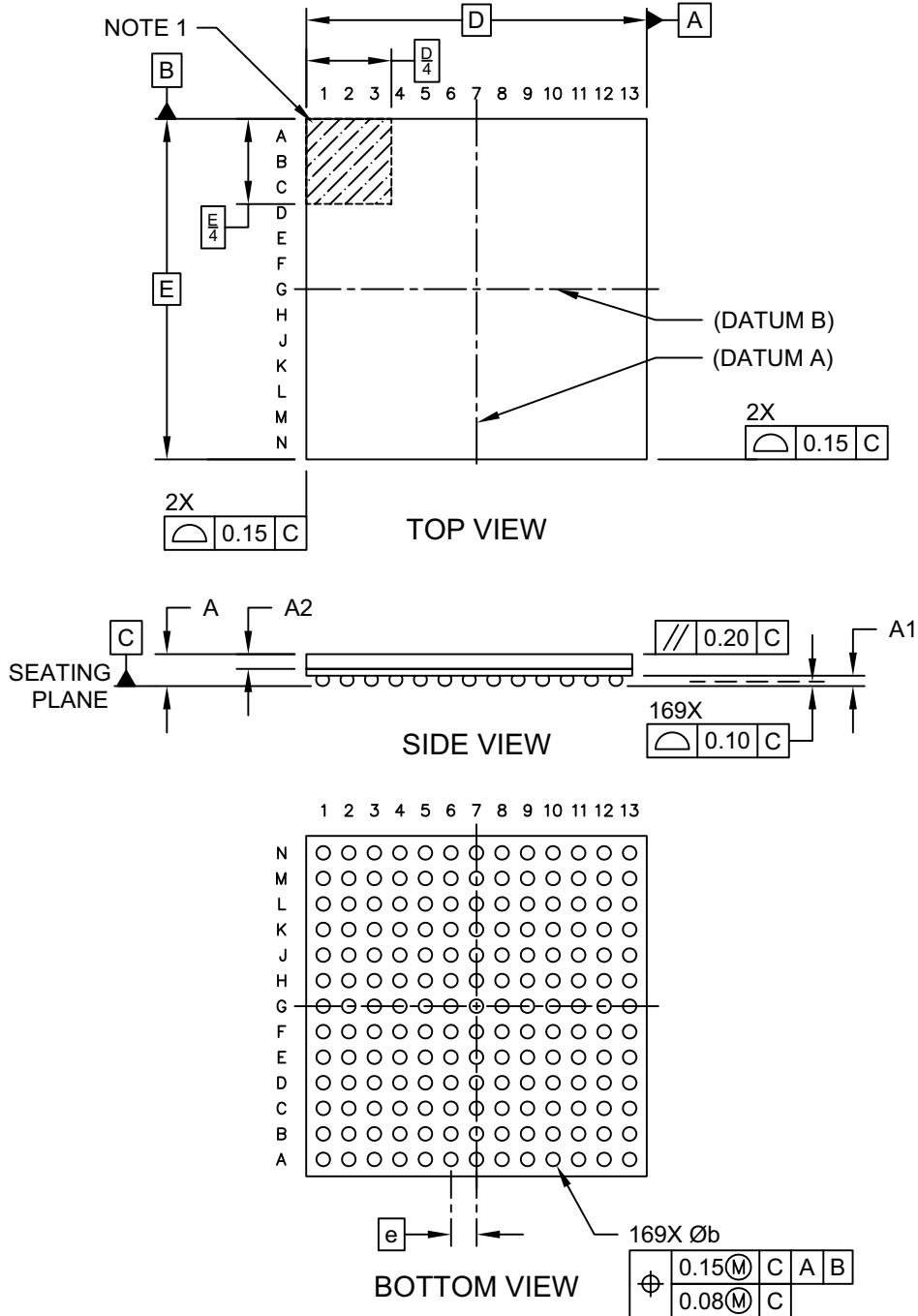

Microchip Technology Drawing C04-377-J Rev C Sheet 1 of 2

169-Ball Thin Fine Pitch Ball Grid Array (7G) - 10x10x1.10 mm Body [TFBGA] (Complies with JEDEC Terminal Assignment recommendations)

Note: For the most current package drawings, please see the Microchip Packaging Specification located at <http://www.microchip.com/packaging>

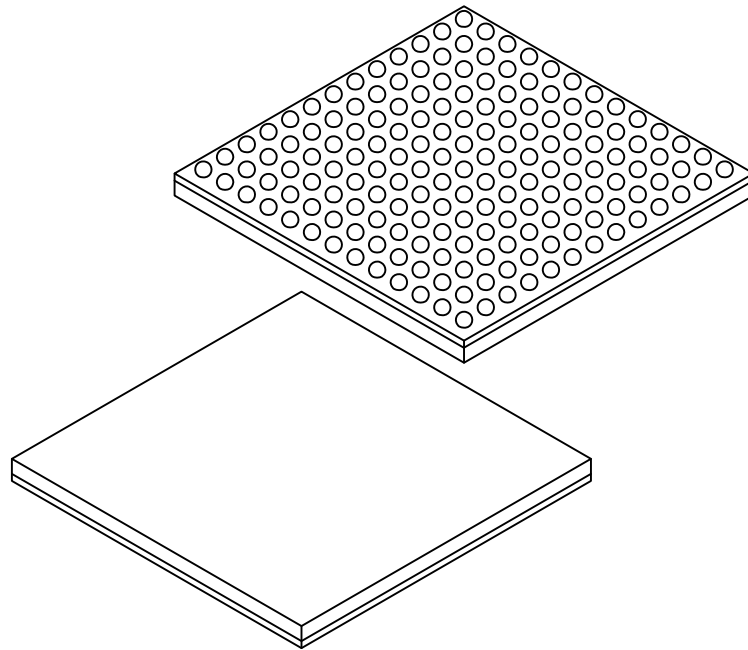

		MILLIMETERS		
		MIN	NOM	MAX
Number of Terminals	N	169		
Pitch	e	0.75 BSC		
Overall Height	A	-	-	1.10
Standoff	A1	0.21	0.32	-
Mold Cap Thickness	A2	0.50	0.45	0.50
Overall Length	D	10.00		
Overall Width	E	10.00		
Ball Diameter	b	0.35	0.40	0.45

Notes:

1. Terminal A1 visual index feature may vary, but must be located within the hatched area.
2. Package is saw singulated
3. Dimensioning and tolerancing per ASME Y14.5M

BSC: Basic Dimension. Theoretically exact value shown without tolerances.

REF: Reference Dimension, usually without tolerance, for information purposes only.

Microchip Technology Drawing C04-377-J Rev C Sheet 2 of 2

HV583

169-Ball Thin Fine Pitch Ball Grid Array (7G) - 10x10x1.10 mm Body [TFBGA] (Complies with JEDEC Terminal Assignment recommendations)

Note: For the most current package drawings, please see the Microchip Packaging Specification located at <http://www.microchip.com/packaging>

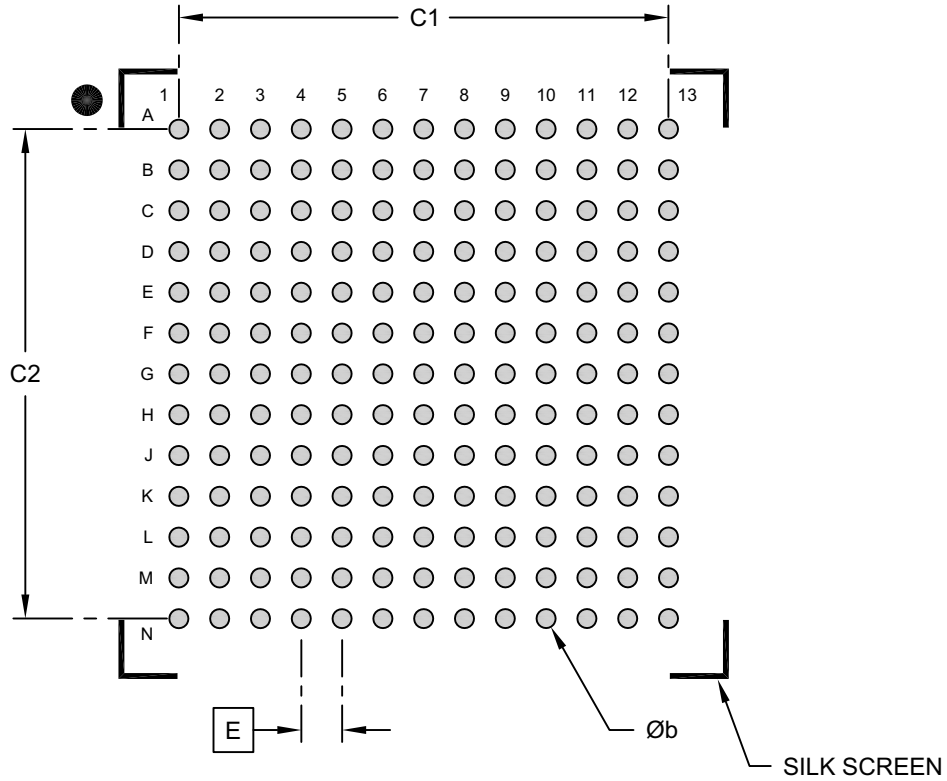

RECOMMENDED LAND PATTERN

Dimension Limits	Units	MILLIMETERS		
		MIN	NOM	MAX
Contact Pitch	E	0.75 BSC		
Contact Pad Spacing	C1		9.00	
Contact Pad Spacing	C2		9.00	
Contact Pad Diameter (X169)	b		0.35	

Notes:

1. Dimensioning and tolerancing per ASME Y14.5M

BSC: Basic Dimension. Theoretically exact value shown without tolerances.

Microchip Technology Drawing C04-2377-J Rev C

APPENDIX A: REVISION HISTORY

Revision B (February 2017)

The following is the list of modifications:

- Updated [AC Electrical Characteristics](#) table.
- Minor typographical corrections.

Revision A (December 2015)

- Original Release of this Document.

HV583

NOTES:

PRODUCT IDENTIFICATION SYSTEM

To order or obtain information, e.g., on pricing or delivery, refer to the factory or the listed sales office.

<u>PART NO.</u>	<u>XX-X</u>
Device	Package
Device:	HV583: Low-Voltage Serial to High-Voltage Parallel Converter with HV Outputs
Package:	GA-G = Thin Fine Pitch Ball Grid Array - 10 x 10 x 1.1 mm Body, 169-lead (TFBGA)

Examples:
a) HV583GA-G: 169-Ball 10x10 TFBGA package

HV583

NOTES:

Note the following details of the code protection feature on Microchip devices:

- Microchip products meet the specification contained in their particular Microchip Data Sheet.
- Microchip believes that its family of products is one of the most secure families of its kind on the market today, when used in the intended manner and under normal conditions.
- There are dishonest and possibly illegal methods used to breach the code protection feature. All of these methods, to our knowledge, require using the Microchip products in a manner outside the operating specifications contained in Microchip's Data Sheets. Most likely, the person doing so is engaged in theft of intellectual property.
- Microchip is willing to work with the customer who is concerned about the integrity of their code.
- Neither Microchip nor any other semiconductor manufacturer can guarantee the security of their code. Code protection does not mean that we are guaranteeing the product as “unbreakable.”

Code protection is constantly evolving. We at Microchip are committed to continuously improving the code protection features of our products. Attempts to break Microchip's code protection feature may be a violation of the Digital Millennium Copyright Act. If such acts allow unauthorized access to your software or other copyrighted work, you may have a right to sue for relief under that Act.

Information contained in this publication regarding device applications and the like is provided only for your convenience and may be superseded by updates. It is your responsibility to ensure that your application meets with your specifications. MICROCHIP MAKES NO REPRESENTATIONS OR WARRANTIES OF ANY KIND WHETHER EXPRESS OR IMPLIED, WRITTEN OR ORAL, STATUTORY OR OTHERWISE, RELATED TO THE INFORMATION, INCLUDING BUT NOT LIMITED TO ITS CONDITION, QUALITY, PERFORMANCE, MERCHANTABILITY OR FITNESS FOR PURPOSE. Microchip disclaims all liability arising from this information and its use. Use of Microchip devices in life support and/or safety applications is entirely at the buyer's risk, and the buyer agrees to defend, indemnify and hold harmless Microchip from any and all damages, claims, suits, or expenses resulting from such use. No licenses are conveyed, implicitly or otherwise, under any Microchip intellectual property rights unless otherwise stated.

Microchip received ISO/TS-16949:2009 certification for its worldwide headquarters, design and wafer fabrication facilities in Chandler and Tempe, Arizona; Gresham, Oregon and design centers in California and India. The Company's quality system processes and procedures are for its PIC® MCUs and dsPIC® DSCs, KEELOQ® code hopping devices, Serial EEPROMs, microperipherals, nonvolatile memory and analog products. In addition, Microchip's quality system for the design and manufacture of development systems is ISO 9001:2000 certified.

**QUALITY MANAGEMENT SYSTEM
CERTIFIED BY DNV
= ISO/TS 16949 =**

Trademarks

The Microchip name and logo, the Microchip logo, AnyRate, AVR, AVR logo, AVR Freaks, BeaconThings, BitCloud, CryptoMemory, CryptoRF, dsPIC, FlashFlex, flexPWR, Helder, JukeBlox, KEELOQ, KEELOQ logo, Klear, LANCheck, LINK MD, maXStylus, maXTouch, MediaLB, megaAVR, MOST, MOST logo, MPLAB, OptoLyzer, PIC, picoPower, PICSTART, PIC32 logo, Prochip Designer, QTouch, RightTouch, SAM-BA, SpyNIC, SST, SST Logo, SuperFlash, tinyAVR, UNI/O, and XMEGA are registered trademarks of Microchip Technology Incorporated in the U.S.A. and other countries.

ClockWorks, The Embedded Control Solutions Company, EtherSynch, Hyper Speed Control, HyperLight Load, IntelliMOS, mTouch, Precision Edge, and Quiet-Wire are registered trademarks of Microchip Technology Incorporated in the U.S.A.

Adjacent Key Suppression, AKS, Analog-for-the-Digital Age, Any Capacitor, AnyIn, AnyOut, BodyCom, chipKIT, chipKIT logo, CodeGuard, CryptoAuthentication, CryptoCompanion, CryptoController, dsPICDEM, dsPICDEM.net, Dynamic Average Matching, DAM, ECAN, EtherGREEN, In-Circuit Serial Programming, ICSP, Inter-Chip Connectivity, JitterBlocker, KlearNet, KlearNet logo, Mindi, MiWi, motorBench, MPASM, MPF, MPLAB Certified logo, MPLIB, MPLINK, MultiTRAK, NetDetach, Omniscient Code Generation, PICDEM, PICDEM.net, PICKit, PICtail, PureSilicon, QMatrix, RightTouch logo, REAL ICE, Ripple Blocker, SAM-ICE, Serial Quad I/O, SMART-I.S., SQI, SuperSwitcher, SuperSwitcher II, Total Endurance, TSHARC, USBCheck, VariSense, ViewSpan, WiperLock, Wireless DNA, and ZENA are trademarks of Microchip Technology Incorporated in the U.S.A. and other countries.

SQTP is a service mark of Microchip Technology Incorporated in the U.S.A.

Silicon Storage Technology is a registered trademark of Microchip Technology Inc. in other countries.

GestIC is a registered trademark of Microchip Technology Germany II GmbH & Co. KG, a subsidiary of Microchip Technology Inc., in other countries.

All other trademarks mentioned herein are property of their respective companies.

© 2015-2017, Microchip Technology Incorporated, All Rights Reserved.

ISBN: 978-1-5224-1394-3



MICROCHIP

Worldwide Sales and Service

AMERICAS

Corporate Office

2355 West Chandler Blvd.
Chandler, AZ 85224-6199
Tel: 480-792-7200
Fax: 480-792-7277
Technical Support:
<http://www.microchip.com/support>

Web Address:
www.microchip.com

Atlanta

Duluth, GA
Tel: 678-957-9614
Fax: 678-957-1455

Austin, TX

Tel: 512-257-3370

Boston

Westborough, MA
Tel: 774-760-0087
Fax: 774-760-0088

Chicago

Itasca, IL
Tel: 630-285-0071
Fax: 630-285-0075

Dallas

Addison, TX
Tel: 972-818-7423
Fax: 972-818-2924

Detroit

Novi, MI
Tel: 248-848-4000

Houston, TX

Tel: 281-894-5983

Indianapolis

Noblesville, IN
Tel: 317-773-8323
Fax: 317-773-5453
Tel: 317-536-2380

Los Angeles

Mission Viejo, CA
Tel: 949-462-9523
Fax: 949-462-9608
Tel: 951-273-7800

Raleigh, NC

Tel: 919-844-7510

New York, NY

Tel: 631-435-6000

San Jose, CA

Tel: 408-735-9110
Tel: 408-436-4270

Canada - Toronto

Tel: 905-695-1980
Fax: 905-695-2078

ASIA/PACIFIC

Asia Pacific Office

Suites 3707-14, 37th Floor
Tower 6, The Gateway
Harbour City, Kowloon

Hong Kong

Tel: 852-2943-5100
Fax: 852-2401-3431

Australia - Sydney

Tel: 61-2-9868-6733
Fax: 61-2-9868-6755

China - Beijing

Tel: 86-10-8569-7000
Fax: 86-10-8528-2104

China - Chengdu

Tel: 86-28-8665-5511
Fax: 86-28-8665-7889

China - Chongqing

Tel: 86-23-8980-9588
Fax: 86-23-8980-9500

China - Dongguan

Tel: 86-769-8702-9880

China - Guangzhou

Tel: 86-20-8755-8029

China - Hangzhou

Tel: 86-571-8792-8115
Fax: 86-571-8792-8116

China - Hong Kong SAR

Tel: 852-2943-5100
Fax: 852-2401-3431

China - Nanjing

Tel: 86-25-8473-2460
Fax: 86-25-8473-2470

China - Qingdao

Tel: 86-532-8502-7355
Fax: 86-532-8502-7205

China - Shanghai

Tel: 86-21-3326-8000
Fax: 86-21-3326-8021

China - Shenyang

Tel: 86-24-2334-2829
Fax: 86-24-2334-2393

China - Shenzhen

Tel: 86-755-8864-2200
Fax: 86-755-8203-1760

China - Wuhan

Tel: 86-27-5980-5300
Fax: 86-27-5980-5118

China - Xian

Tel: 86-29-8833-7252
Fax: 86-29-8833-7256

ASIA/PACIFIC

China - Xiamen

Tel: 86-592-2388138
Fax: 86-592-2388130

China - Zhuhai

Tel: 86-756-3210040
Fax: 86-756-3210049

India - Bangalore

Tel: 91-80-3090-4444
Fax: 91-80-3090-4123

India - New Delhi

Tel: 91-11-4160-8631
Fax: 91-11-4160-8632

India - Pune

Tel: 91-20-3019-1500

Japan - Osaka

Tel: 81-6-6152-7160
Fax: 81-6-6152-9310

Japan - Tokyo

Tel: 81-3-6880-3770
Fax: 81-3-6880-3771

Korea - Daegu

Tel: 82-53-744-4301
Fax: 82-53-744-4302

Korea - Seoul

Tel: 82-2-554-7200
Fax: 82-2-558-5932 or
82-2-558-5934

Malaysia - Kuala Lumpur

Tel: 60-3-6201-9857
Fax: 60-3-6201-9859

Malaysia - Penang

Tel: 60-4-227-8870
Fax: 60-4-227-4068

Philippines - Manila

Tel: 63-2-634-9065
Fax: 63-2-634-9069

Singapore

Tel: 65-6334-8870
Fax: 65-6334-8850

Taiwan - Hsin Chu

Tel: 886-3-5778-366
Fax: 886-3-5770-955

Taiwan - Kaohsiung

Tel: 886-7-213-7830

Taiwan - Taipei

Tel: 886-2-2508-8600
Fax: 886-2-2508-0102

Thailand - Bangkok

Tel: 66-2-694-1351
Fax: 66-2-694-1350

EUROPE

Austria - Wels

Tel: 43-7242-2244-39
Fax: 43-7242-2244-393

Denmark - Copenhagen

Tel: 45-4450-2828
Fax: 45-4485-2829

Finland - Espoo

Tel: 358-9-4520-820

France - Paris

Tel: 33-1-69-53-63-20
Fax: 33-1-69-30-90-79

France - Saint Cloud

Tel: 33-1-30-60-70-00

Germany - Garching

Tel: 49-8931-9700

Germany - Haan

Tel: 49-2129-3766400

Germany - Heilbronn

Tel: 49-7131-67-3636

Germany - Karlsruhe

Tel: 49-721-625370

Germany - Munich

Tel: 49-89-627-144-0
Fax: 49-89-627-144-44

Germany - Rosenheim

Tel: 49-8031-354-560

Israel - Ra'anana

Tel: 972-9-744-7705

Italy - Milan

Tel: 39-0331-742611
Fax: 39-0331-466781

Italy - Padova

Tel: 39-049-7625286

Netherlands - Drunen

Tel: 31-416-690399
Fax: 31-416-690340

Norway - Trondheim

Tel: 47-7289-7561

Poland - Warsaw

Tel: 48-22-3325737

Romania - Bucharest

Tel: 40-21-407-87-50

Spain - Madrid

Tel: 34-91-708-08-90
Fax: 34-91-708-08-91

Sweden - Gothenberg

Tel: 46-31-704-60-40

Sweden - Stockholm

Tel: 46-8-5090-4654

UK - Wokingham

Tel: 44-118-921-5800
Fax: 44-118-921-5820

Mouser Electronics

Authorized Distributor

Click to View Pricing, Inventory, Delivery & Lifecycle Information:

[Microchip:](#)

[HV583GA-G](#)