

MAXWINGDEMO1# Evaluation Kit

Evaluates: MAX44009, MAX31723,
MAX98300, MAX5216

General Description

The MAXWINGDEMO1# evaluation kit is a serial bus experimentation platform that builds upon the MAX32620FTHR board by adding several SPI and I²C peripherals in a featherwing form factor. The MAX32620FTHR is available separately.

The kit includes the following items:

- MAXWINGDEMO1# Featherwing printed circuit board

Features

- MAX44009 Optical Sensor (I²C)
- MAX31723 Temperature Sensor (SPI)
- MAX5216 Digital-to-Analog Convertor (SPI)
- MAX98300 Class-D Audio Amplifier with On-Board SMD Speaker

Ordering Information appears at end of data sheet.

Quick Start

The MAXWINGDEMO1 kit requires a host featherboard or similar MCU platform. This section assumes the a MAX32620FTHR is used. The MAX32620FTHR can require female SIP headers be obtained and soldered in by the user. One 12-pin and one 16-pin 0.1in pitch female header is required.

Demonstration firmware specific to the MAXWINGDEMO1 and the MAX32620FTHR can be obtained through the product web page for the MAXWINGDEMO1 kit. The firmware package contains source code compatible with the Maxim Eclipse Toolchain and a bin file to use directly with the MAX32620FTHR. Refer to the MAX32620FTHR data sheet concerning the programming procedure. Refer to Application Note 6245: *Getting Started with Eclipse* for information about building and debugging firmware images.

Once the image is successfully programmed, the device responds to changes in ambient light level (e.g., passing your hand between the board and a light source) with verbalized temperature measurements.

MAXWINGDEMO1# EV Kit Photo

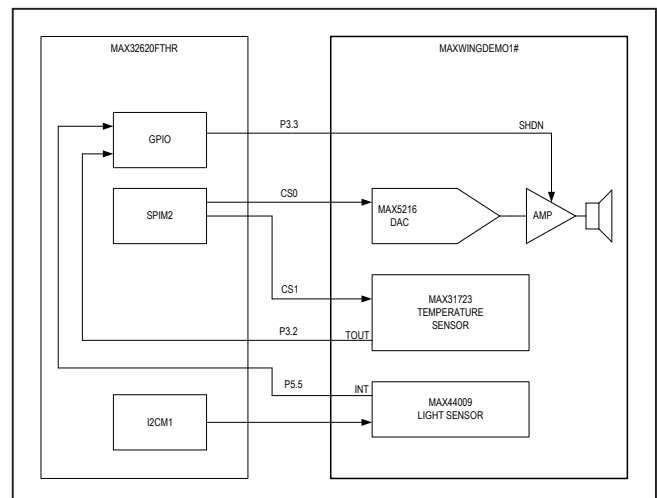
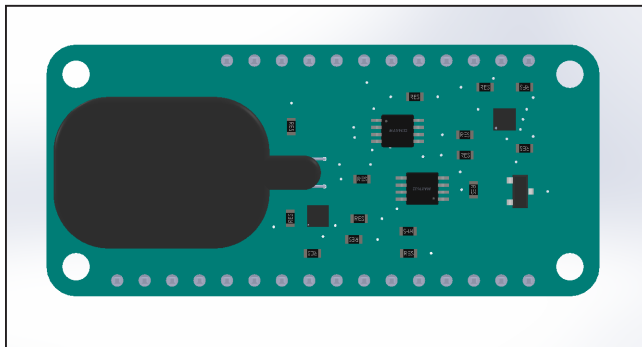

Figure 1. Block Diagram

MAXWINGDEMO1# Evaluation Kit

Evaluates: MAX44009, MAX31723,
MAX98300, MAX5216

Detailed Description

The MAXWINGDEMO1# is designed to attach to the top side of the MAX32620FTHR and provides several I²C and SPI peripherals to the featherboard.

The MAX5216 is a 16-bit digital-to-analog convert that drives an onboard speaker through the MAX98300 audio amplifier. The DAC is connected to the host MCU through the SPIM2 module and uses chip select zero. The MAX31723 temperature sensor is connected to the same SPI bus and uses chip select one. This configuration allows for easy experimentation with SPI bus multiplexing using the SPIM and the peripheral management unit (PMU) in the MAX32620.

The MAX44009 is a light sensor that can measure luminosity from 0.045 lux to 188000 lux. It is connected to the host MCU through the I2CM1 module.

Ordering Information

PART	TYPE
MAXWINGDEMO1#	Evaluation Kit

#Denotes RoHS compliance.

MAXWINGDEMO1# EV Kit Bill of Materials

COMPONENT	MANUFACTURER	PART NUMBER	DESCRIPTION
C1, C3, C4	TDK	C1608X7R1E104K080AA	4.7µF capacitor
C7	TDK	C1608X5R1E106M080AC	10µF capacitor
C5, C6	KEMET	C0603C102K5RAC	1000pF capacitor
J1	SULLINS	PPTC121LFBN-RC	12-pin inline connector
J2	SULLINS	PPPC161LFBN-RC	16-pin inline connector
R1, R2	BOURNS	CR0603-FX-1001ELF	1kΩ resistor
R3–R6	VISHAY	CRCW06030000Z0	0 resistor
R7	VISHAY	PNM0603E5001BS	5kΩ resistor
R8, R8	PANASONIC	ERJ-3GEYJ104	100kΩ resistor
SP1	DB UNLIMITED	SM200808-2	Speaker
U2	MAXIM	MAX44009EDT+	Lux sensor
U3	MAXIM	MAX5216BGUA+	DAC
U4	MAXIM	MAX31723MUA+	Thermometer
U5	MAXIM	MAX98300ETA+	2.6W Class-D audio amplifier
U6	MAXIM	MAX6102EUR+	Voltage reference

MAXWINGDEMO1# EV Kit Schematic

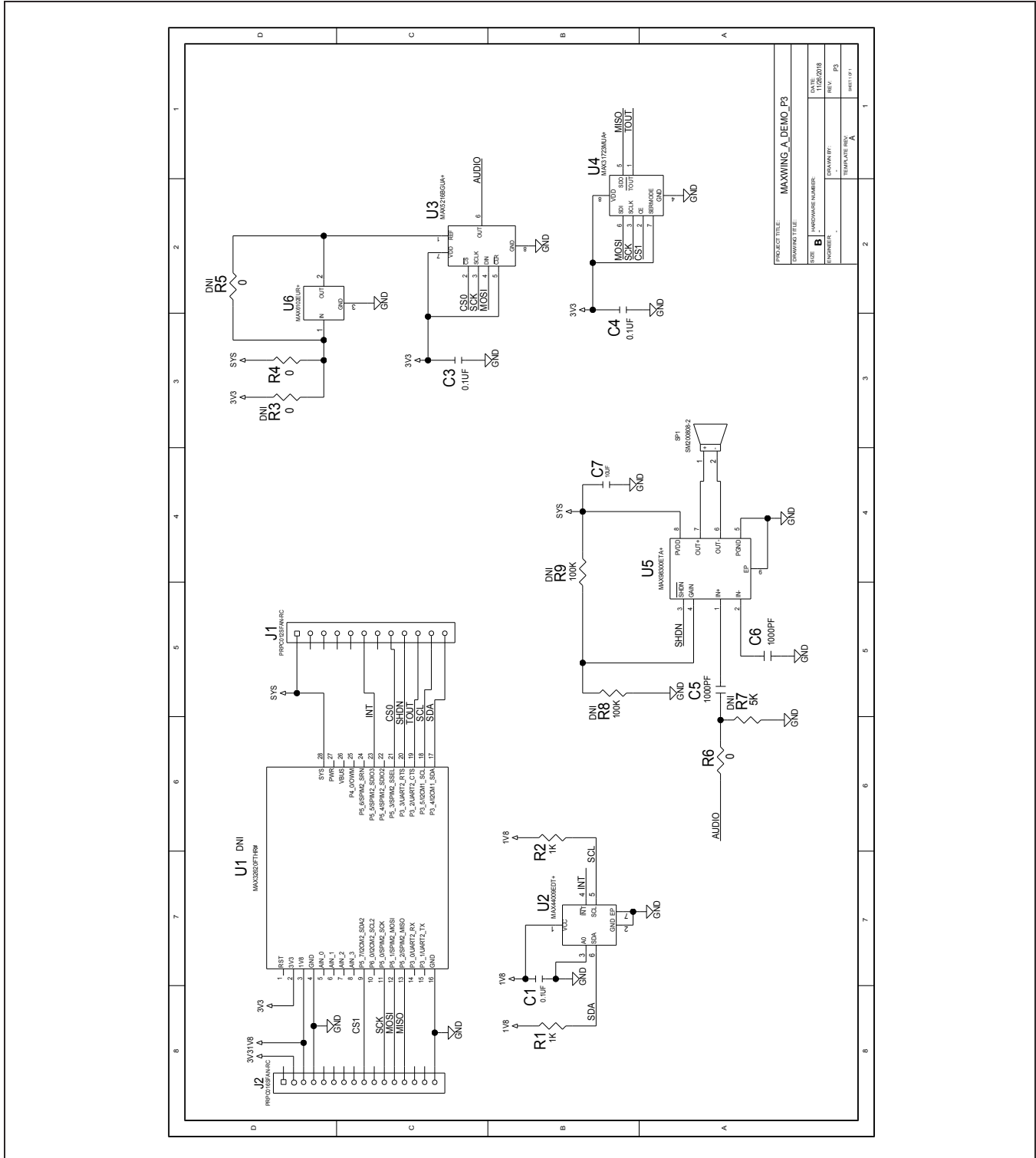

MAXWINGDEMO1# EV Kit PCB Layouts

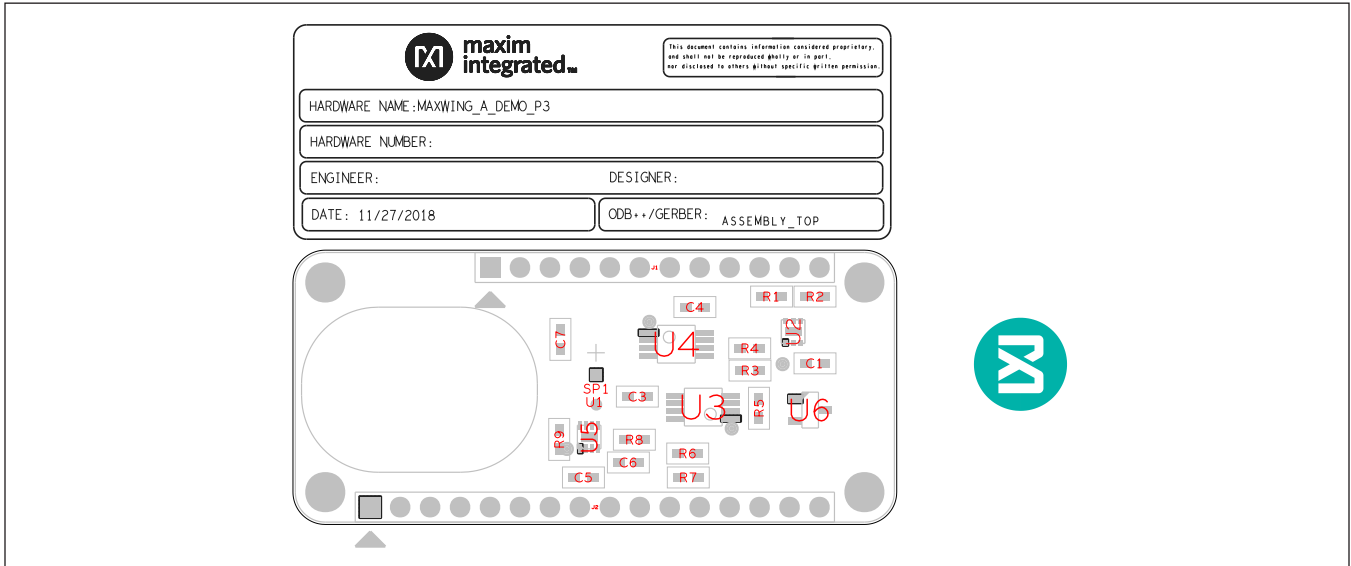

MAXWINGDEMO1#
Evaluation Kit

Evaluates: MAX44009, MAX31723,
MAX98300, MAX5216

Revision History

REVISION NUMBER	REVISION DATE	DESCRIPTION	PAGES CHANGED
0	5/19	Initial release	—

For pricing, delivery, and ordering information, please visit Maxim Integrated's online storefront at <https://www.maximintegrated.com/en/storefront/storefront.html>.

Maxim Integrated cannot assume responsibility for use of any circuitry other than circuitry entirely embodied in a Maxim Integrated product. No circuit patent licenses are implied. Maxim Integrated reserves the right to change the circuitry and specifications without notice at any time.

Mouser Electronics

Authorized Distributor

Click to View Pricing, Inventory, Delivery & Lifecycle Information:

[Maxim Integrated:](#)

[MAXWINGDEMO1#](#)