

## MAX16171 Evaluation Kit

Evaluates: MAX16171

### General Description

The MAX16171 EV kit is designed to evaluate the MAX16171, an ideal diode controller that protects systems against reverse current and reverse voltage faults in automotive applications. The EV kit operates with a supply voltage range of 4V to 57V over the automotive temperature range of -40°C to +125°C. A jumper (J1) helps place the EV kit into low power shutdown mode. The EV kit PCB is available with the MAX16171ATA/VY+ installed.

### Benefits and Features

- 4V to 57V Operating Voltage Range
- Shutdown Mode Jumper
- -40°C to +125°C Temperature Range
- Lead(Pb)-Free and RoHS Compliant
- Proven PCB Layout
- Fully Assembled and Tested

[Ordering Information](#) appears at end of data sheet.

### Quick Start

#### Required Equipment

- MAX16171 EV Kit
- ±25V, 10A DC Power Supply
- Electronic Load
- Oscilloscope
- Two Digital Voltmeters (DVM1, DVM2)

#### Procedure

The MAX16171 EV kit is fully assembled and tested. Follow the steps to verify operation. **Caution:** Do not turn on the power supply until all connections are completed.

- 1) Verify that the jumper (J1) is in its default position as shown in [Table 1](#).
- 2) Connect the DC power supply across IN and PWRGND PCB pads.
- 3) Connect the electronic load between OUT and PGND.
- 4) Connect the positive terminal of DVM1 to GATE and the negative terminal to IN.
- 5) Connect the positive terminal of DVM2 to IN and the negative terminal to OUT.
- 6) Connect channel 1 of the scope to IN to monitor the input voltage.
- 7) Connect channel 2 of the scope to OUT to monitor the output voltage.
- 8) Turn on the power supply and increase the input voltage, while monitoring the input and output on the oscilloscope. The output should follow the input when the input voltage exceeds 0.7V.
- 9) Increase the input voltage up to 12V. DVM1 should read about 2.5V, while DVM2 should read about 20mV with no load at the output.
- 10) Slowly increase the load current while monitoring DVM1 and DVM2. The voltage on DVM1 should increase as the load is increased, while DVM2 should read close to 20mV. The EV kit is ready for further evaluation. Refer to the *MAX16171 data sheet* for more details.

## Detailed Description

The MAX16171 EV kit evaluates the MAX16171, an ideal diode controller and protection device that protects systems against fault conditions such as reverse current, reverse voltage, and negative transients. The MAX16171 controls a single N-channel MOSFET connected between the source and load. In shutdown mode, the MAX16171 turns off the MOSFET(Q1) by pulling GATE to SRC but allows power-flow to the load through the body diode of the MOSFET. Thus, the system can remain in standby mode while the MAX16171 consumes 1 $\mu$ A (typ) of current. In light load applications, the MAX16171 controls gate voltage to maintain a 20mV regulation voltage between source and drain of the MOSFET. At higher load currents, the MAX16171's charge pump increases the gate-to-source voltage to drive the MOSFET into an enhanced mode of operation. When the gate-to-source voltage reaches its maximum drive voltage due to increased load current, the MOSFET should be fully on and the drop across the MOSFET is determined by its  $R_{DS(ON)}$  and load current.

### Enable Input, EN

The MAX16171 EV kit provides a jumper (J1) to enable or disable the MAX16171. See [Table 1](#) for J1 jumper settings. Pulling EN to ground allows the MAX16171 to enter the shutdown mode and reduce the device supply current to 1 $\mu$ A (typ). While in shutdown, the power can still flow to the load through the body diode of the MOSFET. Therefore, excessive load current while the device is in shutdown should be avoided to minimize power loss.

**Table 1. EN Input (J1)**

SHUNT POSITION	DESCRIPTION
Installed*	Enabled. VEN = VIN
Not Installed	Disabled. VEN = GND

\*Default Position

## Input Transient Protection

The MAX16171 EV kit tolerates input transients from +76V down to -42V without damage to the MAX16171 and on-board components. To increase the positive and negative transient beyond the absolute maximum ratings of the MAX16171, the EV kit features optional footprints for external TVS diodes (D1 and D2) to clamp input transients exceeding the protection range offered by the IC. See the [MAX16171 EV Kit Schematic Diagrams](#) for proper orientation and connection.

## Optional Components

The EV kit features optional components to facilitate the evaluation of the MAX16171 in a system. A Schottky diode (D4) in the SOD123 package between the system and IC grounds provides an alternative protection scheme in case D2 is not desirable. If D4 is installed, the path underneath its footprint must be cut to disconnect the IC ground from the system ground. In such a configuration, the IC ground remains a diode drop above the system ground during normal operation. In reverse voltage conditions, D4 is reverse biased and blocks the negative input transients while D1 is forward biased keeping the voltage drop across the MAX16171 to -0.7V.

The MAX16171 also features optional input/output capacitors, C2 and C3. For systems that do not require a huge capacitive load, C2 provides the option to evaluate the MAX16171 with smaller capacitor values. Similarly, bypassing the capacitor (C3) offers the ability to optimize and modify the bypassing scheme in case having C1 alone on the board does not meet system requirements.

**Note:** These optional components are not necessary for the proper operation of the MAX16171 but are provided to optimize system operation, facilitate testing, and evaluation of the IC.

## Component List

PART	QTY	DESCRIPTION
C1	2	0.1 $\mu$ F $\pm$ 10%, 100V X7R ceramic capacitors (1206) Murata: GRM319R72A104KA01 TDK: C3216X7R2A104K160AA Kemet: C1206C104K1RAC
C2	0	Not installed. Ceramic capacitor (1206)
C3	0	Not installed. Ceramic capacitor (1206)
C4	1	100 $\mu$ F $\pm$ 20%, 80V (Case 1213), Aluminum Electrolytic, Vishay: MAL214699706E3
D1	0	Not installed. TVS diode
D2	0	Not installed. TVS diode
D4	0	Not installed. Schottky diode (SOD123)

PART	QTY	DESCRIPTION
GATE	1	Test Point Keystone 5012
ICGND, IN, OUT, PWRGND, PWRGND1	5	20G bus wire formed into "U" shape loop; NATURAL; SOLID; WEICO WIRE; SOFT DRAWN BUS TYPE-S; 20AWG
IN1, OUT1, PGND, TP2	4	Banana Jacks
J1	1	Banana Jacks
Q1	1	100V, 75A, N-channel MOSFET (TO-263) Vishay: SQM70060EL_GE3
U1	4	MAX16171ATA+
—	1	PCB: MAX16171 EVALUATION KIT

## Component Suppliers

SUPPLIER	PHONE	WEBSITE
Würth Electronics Inc.	248 756-5355	www.we-online.com
Murata Electronics North America, Inc.	770-436-1300	www.murata.com
TDK Corp.	847-803-6100	www.component.tdk.com
Vishay Semiconductors	402-563-6866	www.vishay.com

**Note:** Indicate that you are using the MAX16171 when contacting these component suppliers.

## Ordering Information

PART	TYPE
MAX16171EVKIT#	EV Kit

#Denotes RoHS compliant.

MAX16171 EV Kit Schematic Diagrams

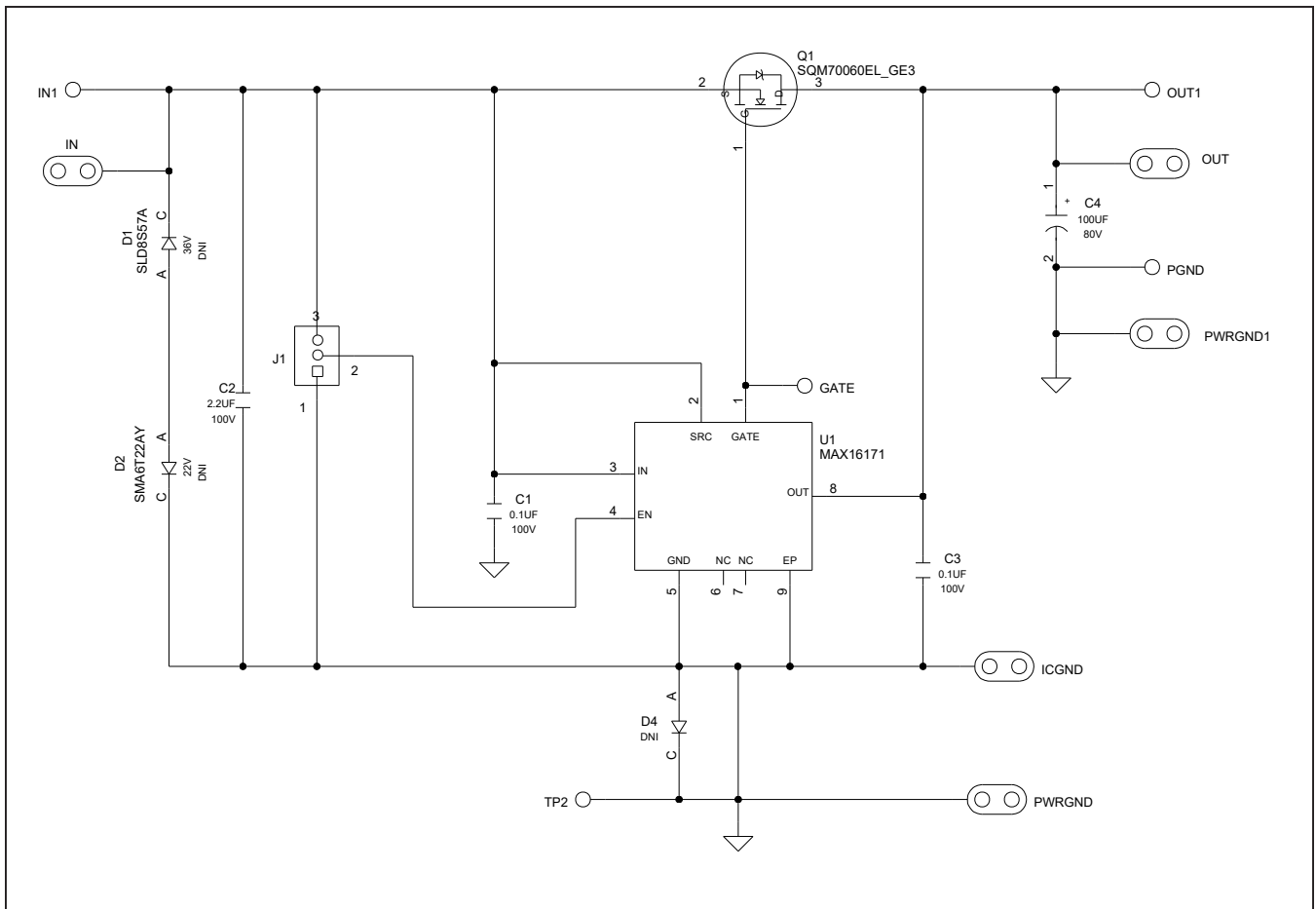
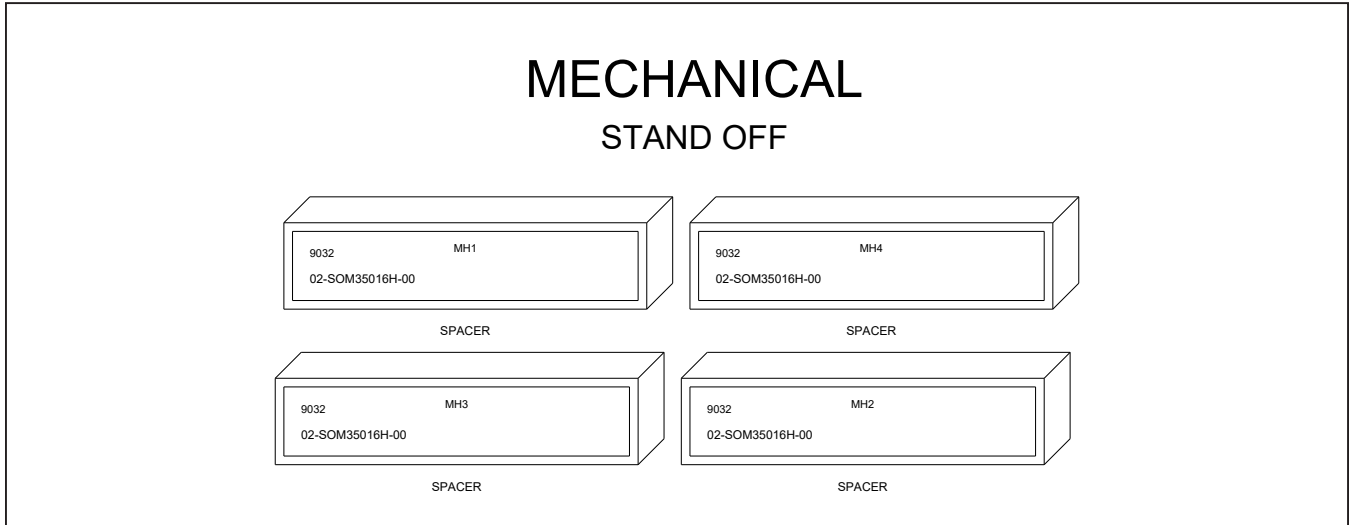

### MAX16171 EV Kit PCB Layout Diagrams

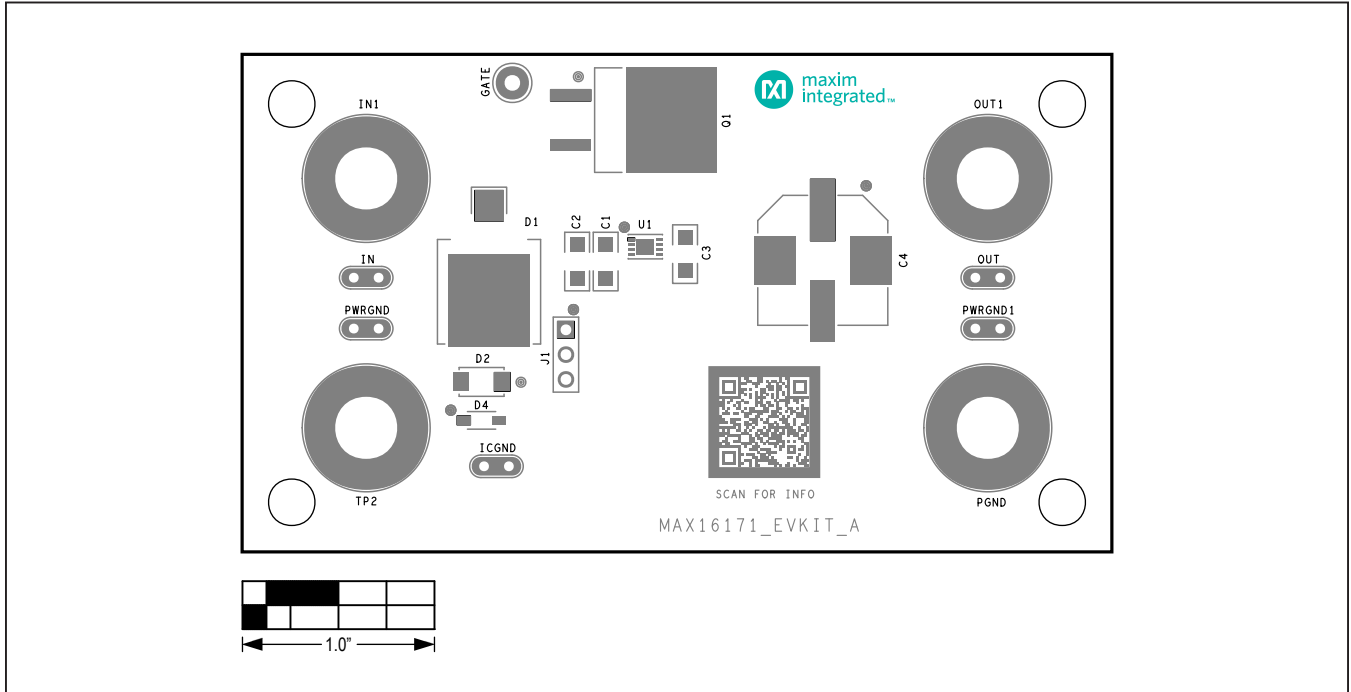

MAX16171 EV Kit PCB Layout—Top Silkscreen

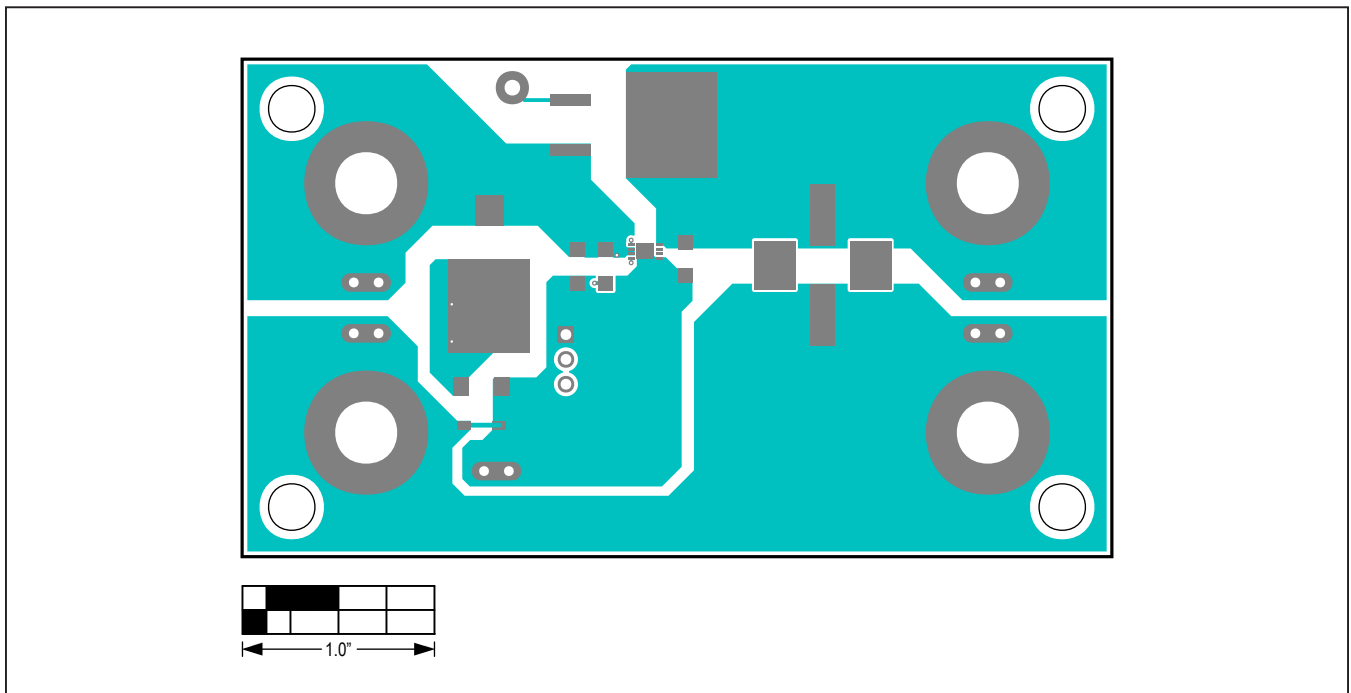

MAX16171 EV Kit PCB Layout—Top View

MAX16171 EV Kit PCB Layout Diagrams (continued)

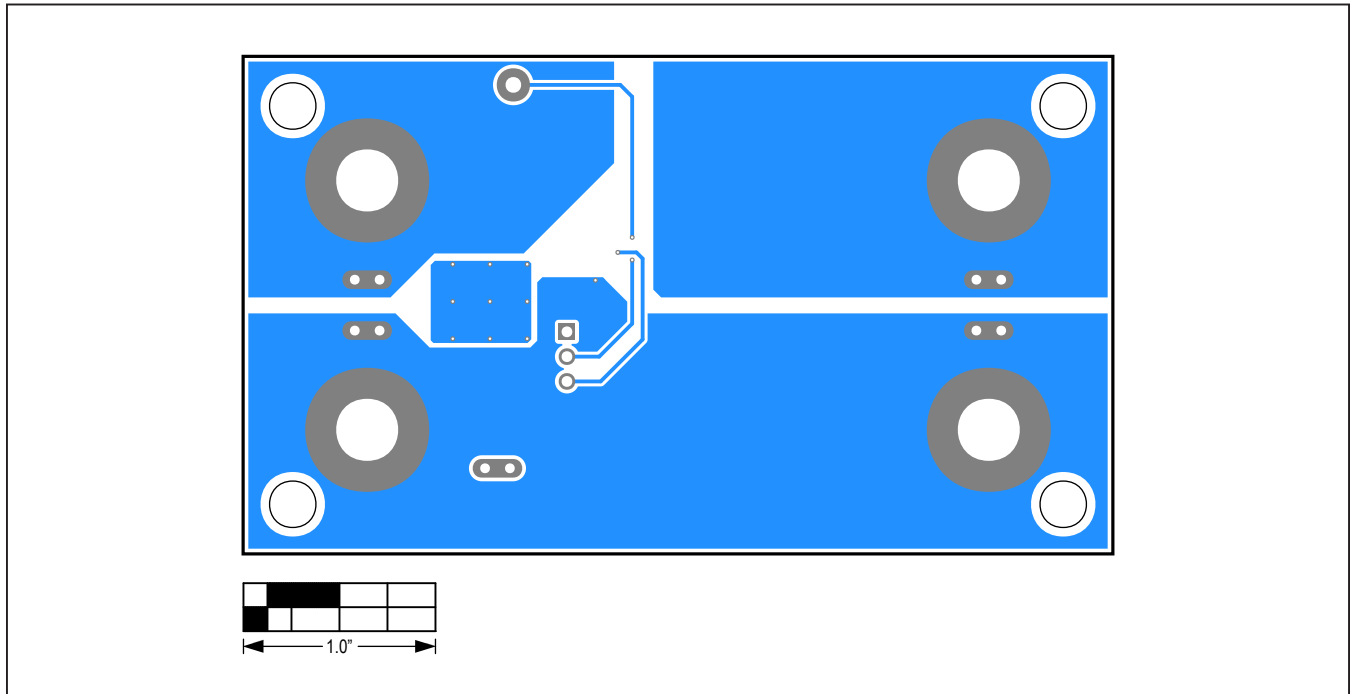

MAX16171 EV Kit PCB Layout—Bottom View

### Revision History

REVISION NUMBER	REVISION DATE	DESCRIPTION	PAGES CHANGED
0	10/20	Initial release	—

For pricing, delivery, and ordering information, please visit Maxim Integrated's online storefront at <https://www.maximintegrated.com/en/storefront/storefront.html>.

*Maxim Integrated cannot assume responsibility for use of any circuitry other than circuitry entirely embodied in a Maxim Integrated product. No circuit patent licenses are implied. Maxim Integrated reserves the right to change the circuitry and specifications without notice at any time.*

# Mouser Electronics

Authorized Distributor

Click to View Pricing, Inventory, Delivery & Lifecycle Information:

[Maxim Integrated:](#)

[MAX16171EVKIT#](#)