

Low Noise FTTx Amplifier 50 - 1000 MHz

Rev. V1

Features

- Low Distortion
- Low Noise Figure
- Lead-Free 4 mm 20-Lead PQFN Package
- Halogen-Free “Green” Mold Compound
- 260°C Reflow Compatible

Description

The MAAM-010239 is a GaAs pHEMT MMIC amplifier in a lead-free 4mm 20-lead PQFN package. The amplifier is designed to meet the high gain, high linearity and low noise requirements of FTTx receivers.

Ordering Information ^{1,2}

Part Number	Package
MAAM-010239-TR1000	1000 piece reel
MAAM-010239-TR3000	3000 piece reel
MAAM-010239-001SMB	Sample Test Board

1. Reference Application Note M513 for reel size information.
2. All sample boards include 5 loose parts.

Absolute Maximum Ratings ^{3,4,5}

Parameter	Absolute Maximum
Max Input Power	-5 dBm
Operating Voltage	+10.0 V
Operating Temperature	-20°C to +85°C
Junction Temperature ⁶	+150°C
Storage Temperature	-65°C to +150°C

3. Exceeding any one or combination of these limits may cause permanent damage to this device.
4. M/A-COM Technology Solutions does not recommend sustained operation near these survivability limits.
5. These operating conditions will ensure MTTF > 1 x 10⁶ hours.
6. Junction Temperature (T_J) = T_A + Θ_{Jc} * (V * I)
Typical thermal resistance (Θ_{Jc}) = 51 °C/W.
 - a) For T_A = 25°C,
T_J = 80 °C @ 5.0 V, 215 mA
 - b) For T_A = 85°C,
T_J = 140 °C @ 5.0 V, 215 mA

* Restrictions on Hazardous Substances, European Union Directive 2002/95/EC.

Functional Schematic

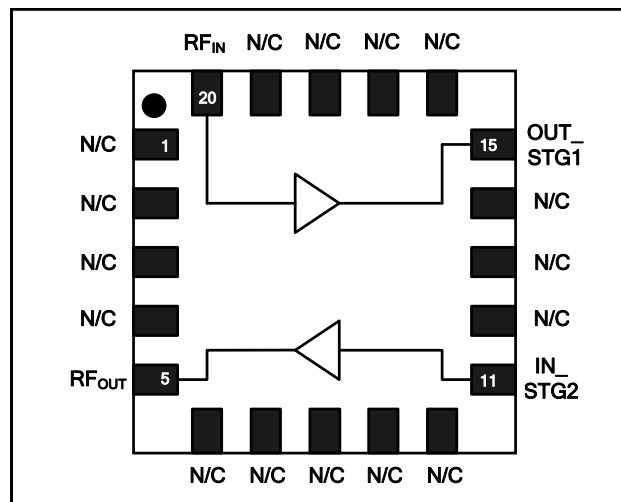

Pin Configuration

Pin No.	Pin Name	Description
1	N/C	No Connection
2	N/C	No Connection
3	N/C	No Connection
4	N/C	No Connection
5	RF _{OUT}	RF Output
6	N/C	No Connection
7	N/C	No Connection
8	N/C	No Connection
9	N/C	No Connection
10	N/C	No Connection
11	IN_STG2	STAGE 2 RF Input
12	N/C	No Connection
13	N/C	No Connection
14	N/C	No Connection
15	OUT_STG1	STAGE 1 RF Output
16	N/C	No Connection
17	N/C	No Connection
18	N/C	No Connection
19	N/C	No Connection
20	RF _{IN}	RF Input
21	Paddle ⁷	RF and DC Ground

7. The exposed pad centered on the package bottom must be connected to RF and DC ground.

Low Noise FTTx Amplifier 50 - 1000 MHz

Rev. V1

Electrical Specifications: $T_A = 25^\circ\text{C}$, Freq: 50 - 1000 MHz, $V_{DD} = +5$ Volts, $Z_0 = 75 \Omega$

Parameter	Test Conditions	Units	Min.	Typ.	Max.
Gain	RF _{IN} to RF _{OUT} 51 MHz 1 GHz	dB	29 29.5	30 30.5	31 31.5
Gain Flatness	RF _{IN} to RF _{OUT}	dB	-	0.5	1
Noise Figure	RF _{IN} to RF _{OUT}	dB	-	3.5	4.5
Input Return Loss	RF _{IN}	dB	-	15	-
Output Return Loss	RF _{OUT}	dB	-	15	-
Reverse Isolation	RF _{OUT} to RF _{IN}	dB	-	37	-
P1dB	400 MHz	dBm	-	20	-
Output IP2	Two tones, 400 MHz, +5 dBm output per tone	dBm	-	62	-
Output IP3	Two tones, 400 MHz, +5 dBm output per tone	dBm	-	35	-
Composite Triple Beat, CTB	132 Channels, +30 dBmV/Channel at the Output	dBc	-60	-65	-
Composite Second Order, CSO	132 Channels, +30 dBmV/Channel at the Output	dBc	-55	-60	-
Cross modulation	132 Channels, +30 dBmV/Channel at the Output	dBc	-	-65	-
I _{DD}	V _{DD} = +5 Volts	mA	-	215	250

Recommended PCB Layout

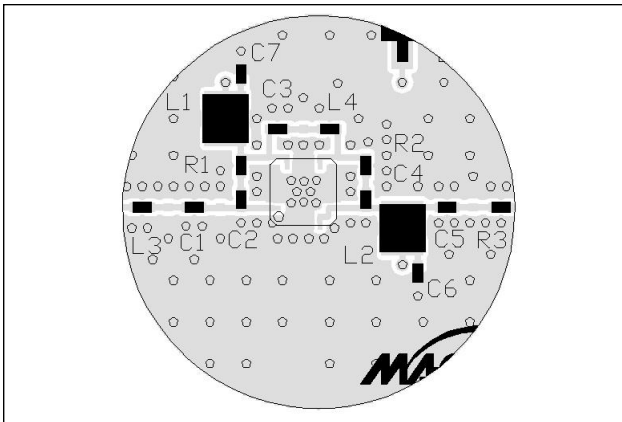

Test Circuit Schematic

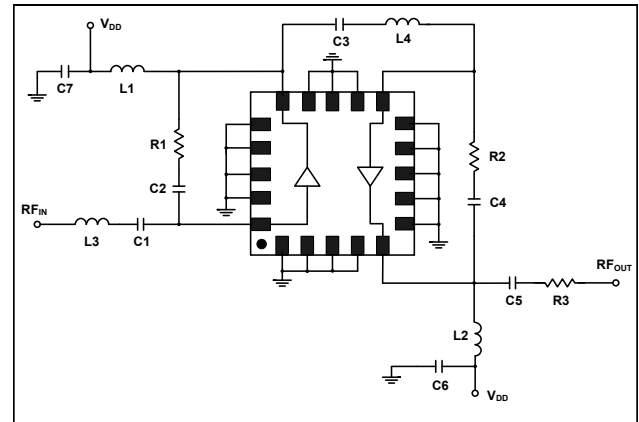

Off-Chip Component Values

Component	Value	Package
C1-C7	0.01 μF	0402
L1, L2 ⁸	1.0 μH	1210
L3	6.8 nH	0402
L4	1.8 nH	0402
R1	470 Ω	0402
R2	430 Ω	0402
R3	0 Ω	0402

8. L1 and L2 supplied from EPCOS, part number B82422A1102K100.

Typical Performance Curves:

Gain to 1 GHz over Temperature

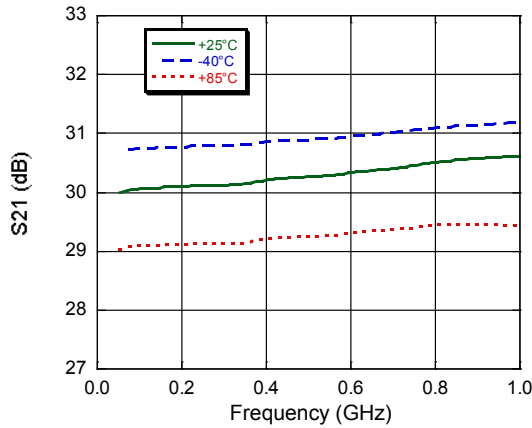

Gain to 3 GHz over Temperature

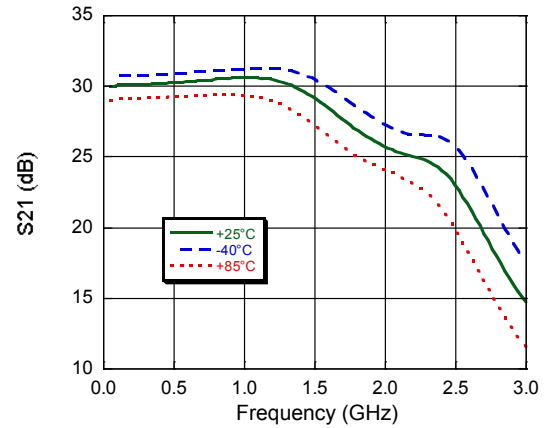

Input Return Loss over Temperature

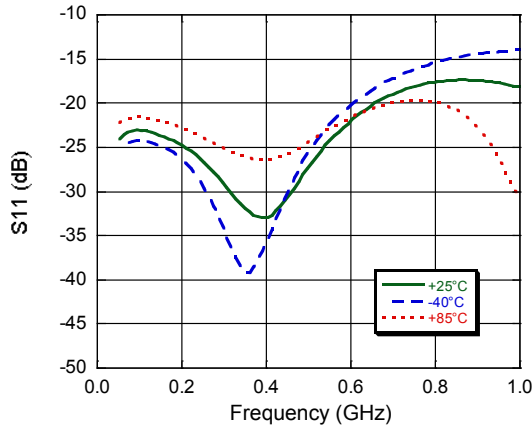

Output Return Loss over Temperature

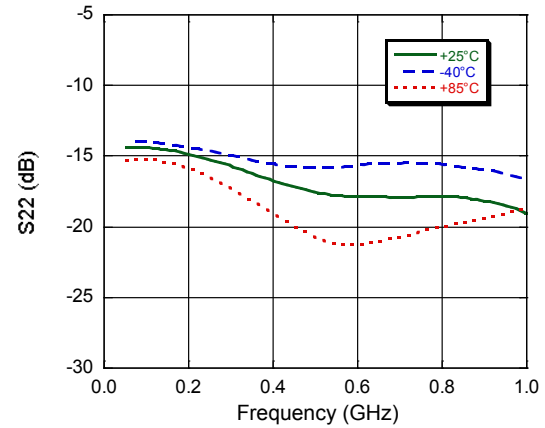

Reverse Isolation

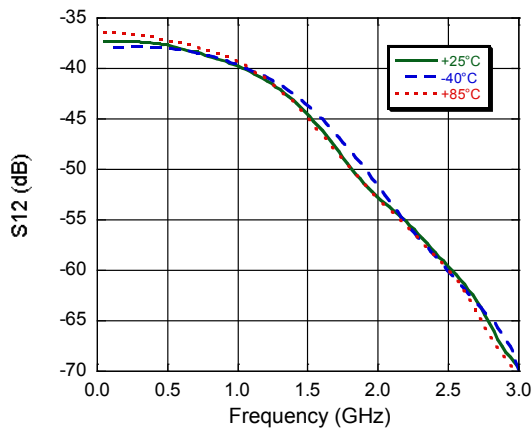

Noise Figure

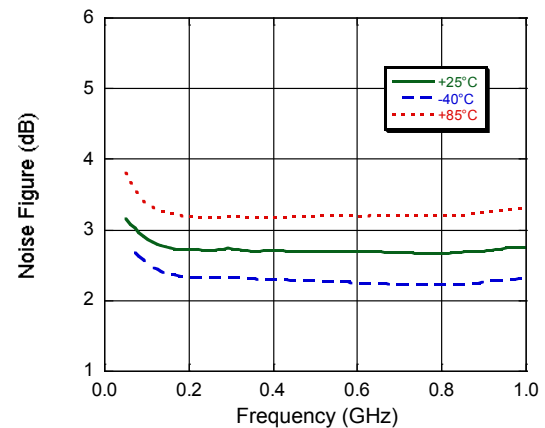

Lead-Free 4 mm 20-Lead PQFN†

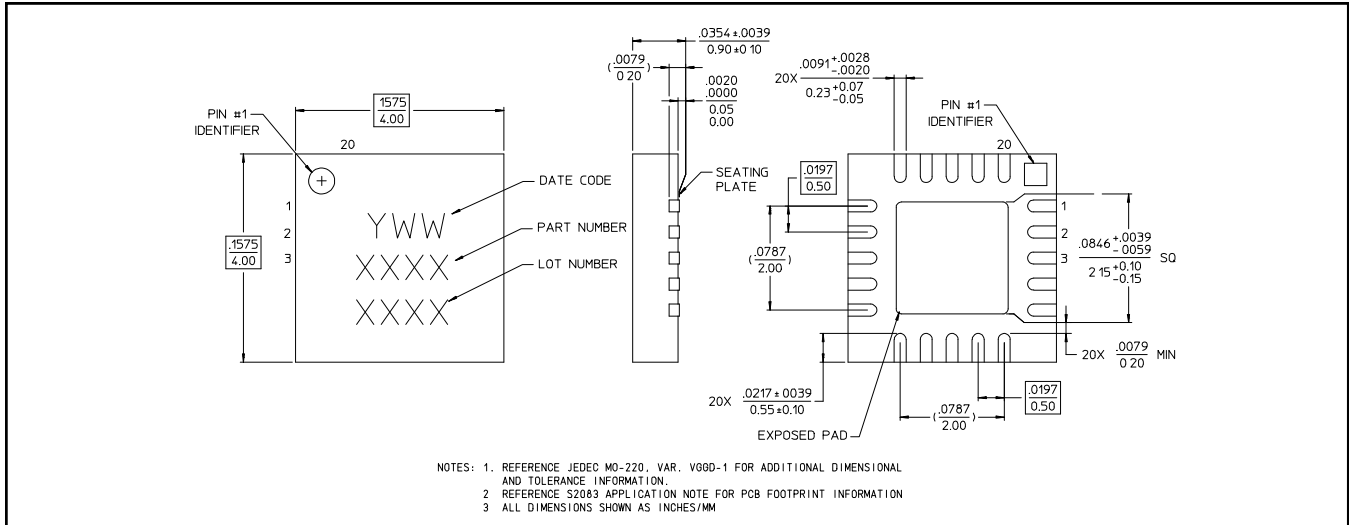

† Reference Application Note S2083 for lead-free solder reflow recommendations.
 Meets JEDEC moisture sensitivity level 1 requirements.
 Plating is 100% matte tin over copper.

Handling Procedures

Please observe the following precautions to avoid damage:

Static Sensitivity

Gallium Arsenide Integrated Circuits are sensitive to electrostatic discharge (ESD) and can be damaged by static electricity. Proper ESD control techniques should be used when handling these devices.

An external protection circuit using an inexpensive anti-parallel diode pair can be used to protect the IC. Please reference application note AN3028 on <http://www.macomtech.com> for further detail.

M/A-COM Technology Solutions Inc. All rights reserved.

Information in this document is provided in connection with M/A-COM Technology Solutions Inc ("MACOM") products. These materials are provided by MACOM as a service to its customers and may be used for informational purposes only. Except as provided in MACOM's Terms and Conditions of Sale for such products or in any separate agreement related to this document, MACOM assumes no liability whatsoever. MACOM assumes no responsibility for errors or omissions in these materials. MACOM may make changes to specifications and product descriptions at any time, without notice. MACOM makes no commitment to update the information and shall have no responsibility whatsoever for conflicts or incompatibilities arising from future changes to its specifications and product descriptions. No license, express or implied, by estoppel or otherwise, to any intellectual property rights is granted by this document.

THESE MATERIALS ARE PROVIDED "AS IS" WITHOUT WARRANTY OF ANY KIND, EITHER EXPRESS OR IMPLIED, RELATING TO SALE AND/OR USE OF MACOM PRODUCTS INCLUDING LIABILITY OR WARRANTIES RELATING TO FITNESS FOR A PARTICULAR PURPOSE, CONSEQUENTIAL OR INCIDENTAL DAMAGES, MERCHANTABILITY, OR INFRINGEMENT OF ANY PATENT, COPYRIGHT OR OTHER INTELLECTUAL PROPERTY RIGHT. MACOM FURTHER DOES NOT WARRANT THE ACCURACY OR COMPLETENESS OF THE INFORMATION, TEXT, GRAPHICS OR OTHER ITEMS CONTAINED WITHIN THESE MATERIALS. MACOM SHALL NOT BE LIABLE FOR ANY SPECIAL, INDIRECT, INCIDENTAL, OR CONSEQUENTIAL DAMAGES, INCLUDING WITHOUT LIMITATION, LOST REVENUES OR LOST PROFITS, WHICH MAY RESULT FROM THE USE OF THESE MATERIALS.

MACOM products are not intended for use in medical, lifesaving or life sustaining applications. MACOM customers using or selling MACOM products for use in such applications do so at their own risk and agree to fully indemnify MACOM for any damages resulting from such improper use or sale.

5

M/A-COM Technology Solutions Inc. (MACOM) and its affiliates reserve the right to make changes to the product(s) or information contained herein without notice.
Visit www.macom.com for additional data sheets and product information.

Mouser Electronics

Authorized Distributor

Click to View Pricing, Inventory, Delivery & Lifecycle Information:

[MACOM:](#)

[MAAM-010239-TR1000](#)