



Z8F08200100KITG

**Z8 Encore! XP[®] F0822 Series
Development Kit**

User Manual

UM015009-0608

Revision History

Each instance in Revision History reflects a change to this document from its previous revision. For more details, refer to the corresponding pages and appropriate links in the table below.

Date	Revision Level	Description	Page No
June 2008	09	Updated Hardware section.	1
May 2008	08	Added Z8F0822SJ020 to the Introduction .	1
March 2008	07	Changed title to Z8 Encore! XP® F0822 Series Development Kit User Manual	All
December 2007	06	Updated document with new Zilog logo and disclaimer. Implemented Style Guide. Replaced Z8 Encore!® 8K/4K Series with Z8 Encore! XP® F0822 Series Flash Microcontrollers.	All
November 2006	05	Changed Figure 14 to Figure 2.	5
November 2005	04	Removed the word Preliminary from all page footers and updated trademarks.	All

Table of Contents

Introduction	1
Safeguards	1
Kit Contents	1
Hardware	1
Software (on CD-ROM)	2
Documentation	3
System/Software Requirements	3
Supported Host System Configuration	3
Installation	4
Z8 Encore! XP® F0822 Series Evaluation Board	5
Features	6
MCU	6
UART with IrDA Endec	8
Crystal Oscillator	8
Power and Communication Interfaces	8
External Interface Headers JP1 and JP2	9
Schematics	10
Customer Support	12

Introduction

Zilog's Z8 Encore! XP® F0822 Series is a part of Zilog® microcontroller products. The Z8 Encore! XP® MCU development kit (Z8F08200100KITG) allows you to get familiar with the hardware and software tools available with this product. This kit consists of the 8 KB version of the Z8 Encore! XP evaluation board that supports and presents the features of the Z8 Encore! XP F0822 Series. This kit allows you to write application software and contains all supporting documents.

Z8F0822SJ020 is the silicon used in the board. For more details, refer to *Z8 Encore! XP® F0822 Series Flash Microcontrollers Product Specification (PS0225)* available for download at www.zilog.com.

This user manual acquaints you with the Z8 Encore! XP F0822 Series development kit and provides instructions on setting up and using the tools to start building designs and applications.

Safeguards

The following precaution must be observed when working with the devices described in this document.



Caution: *Always use a grounding strap to prevent damage resulting from electrostatic discharge (ESD).*

Kit Contents

Z8 Encore! XP F0822 Series development kit (see [Figure 1](#) on page 2) contains the following:

Hardware

The hardware included are:

- Z8 Encore! XP F0822 Series evaluation board

- USB Smart Cable for PC to Z8 Encore! XP[®] F0822 series development board (previous versions of the development kit use a Serial Smart Cable. Refer to your original documentation for information on using the Serial Smart Cable).
- 5 V DC power supply



Figure 1. Z8 Encore! XP[®] MCU Development Kit Contents

Software (on CD-ROM)

The software (on CD-ROM) includes:

- Zilog Developer Studio (ZDS II)- Z8 Encore! IDE with ANSI C-Compiler
- Sample code

- Document browser
- Acrobat Reader

Documentation

The documentation includes:

- Quick Start Guide
- Z8 Encore! XP F0822 Series technical documentation (on CD-ROM):
 - Development kit User Manual
 - ZDS II - IDE User Manual
 - eZ8™ CPU User Manual
 - Product Specification
 - Product Brief
 - Programmer's Reference Sheet

The sample code is installed with ZDS II and resides in the disk drive at:
<installation directory>\samples

The documentation can be installed with the DemoShield interface or can be viewed on the CD-ROM using the DemoShield menus and a PDF reader. A copy of the Acrobat installer is provided on the CD-ROM and can be installed from the DemoShield install screen. After installing the documentation, Windows Explorer can be used to select any document to be viewed with PDF file viewer.

System/Software Requirements

An IBM PC (or compatible computer) with the following minimum configurations:

Supported Host System Configuration

The host system configuration for Z8 Encore! XP F0822 Series development kit includes:

- Win98 Second Edition/ WinNT 4.0 Service Pack 6/ Win2000 Service Pack 3/ WinXP Service Pack 1
- Pentium II/233 MHz processor or higher up to Pentium IV, 2.8 GHz

- 96 MB RAM or more
- 25 MB hard disk space or more
- Super VGA video adapter
- CD-ROM
- One or more RS-232 communication ports

Installation

Follow the directions in the Quick Start Guide for software installation and setup of the Z8 Encore! XP development kit.

Z8 Encore! XP[®] F0822 Series Evaluation Board

Z8 Encore! XP[®] F0822 Series evaluation board (see [Figure 2](#)) is an evaluation and prototyping board for the Z8 Encore! XP F0822 Series. The board provides you with a tool to evaluate features of Z8 Encore! XP F0822 Series, and to start developing an application before building the hardware.

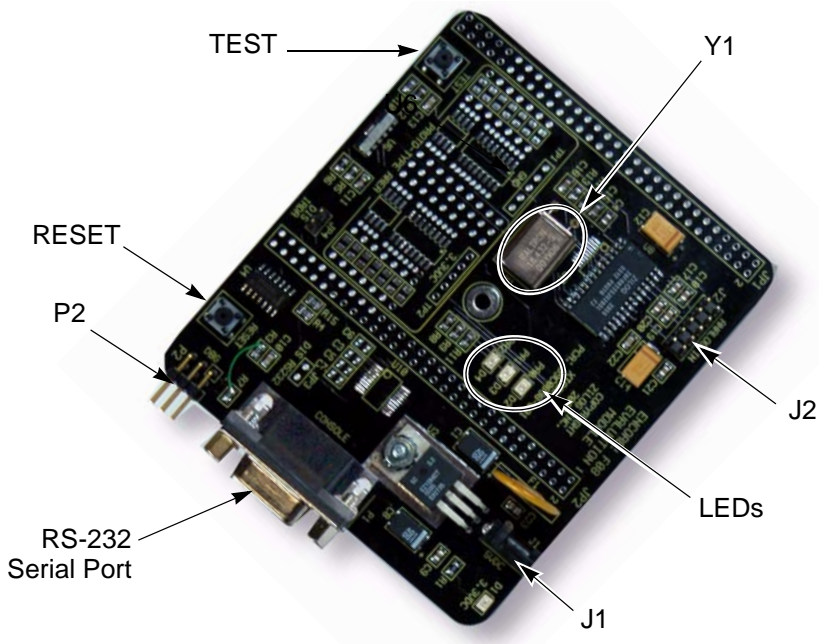

Figure 2. Z8 Encore! XP F0822 Series Evaluation Board

Features

The features of Z8 Encore! XP F0822 Series evaluation board include:

- Z8 Encore! XP MCU (28-pin SOIC)
- 3 LEDs
- RS-232 interface
- IrDA transceiver
- Two pushbuttons—RESET and TEST
- 5 V DC power connector
- On-Chip Debugger (OCD) interface
- Crystal Oscillator at 18.432 MHz
- Header for ADC input
- Prototyping area
- External interface connectors JP1 and JP2
- 2.7 V to 3.6 V operating voltage with 5 V-tolerant inputs

MCU

Z8 Encore! XP F0822 Series is member of Zilog family of microcontroller products based upon the 8-bit eZ8™ core CPU. The Flash in-circuit programming capability allows for faster development time and program changes in the field. The eZ8 core CPU is upward compatible with existing Z8® instructions. The rich peripheral set of Z8 Encore! XP F0822 Series makes it suitable for various applications including motor control, security systems, home appliances, personal electronic devices, and sensors.

The evaluation board contains circuitry to support and present all the features of the Z8 Encore! XP F0822 Series.

The main features of Z8 Encore! XP F0822 Series include:

- eZ8™ core CPU
- 8 KB Flash memory with in-circuit programming capability
- 1 KB register RAM
- 5-channel, 10-bit Analog-to-Digital Converter (ADC)
- Full-duplex UART
- I²C interface (Master Mode only)
- Serial Peripheral Interface (SPI)
- Infrared Data Association (IrDA)-compliant infrared encoder/decoder (Endec)
- Two 16-bit timers with capture, compare, and PWM capability
- Watchdog Timer (WDT) with internal RC oscillator
- Eleven or nineteen I/O pins
- Programmable priority interrupts
- On-Chip Debugger
- Voltage Brownout Protection (VBO)
- Power-On Reset (POR)
- 2.7 V to 3.6 V operating voltage with 5 V-tolerant inputs
- Operating temperatures: 20 °C ±10 °C

For further information on the Z8 Encore! XP family of devices, refer to *Z8 Encore! XP® F0823 Series Product Specification (PS0243)* available for download at www.zilog.com.

UART with IrDA Endec

The Z8 Encore! XP F0822 Series contains a fully-functional, high-performance UART with Infrared Encoder/Decoder, component U6. The Infrared ENDEC is integrated with an on-chip UART allowing easy communication between the Z8 Encore! XP F0822 Series Flash MCU and IrDA transceivers. Infrared communication provides secure, reliable, low-cost, point-to-point communication between PCs, PDAs, cell phones, printers, and other infrared enabled devices.

Crystal Oscillator

The evaluation board is shipped with an 18.432 MHz Crystal Oscillator (Y1). To change the crystal oscillator you must change the clock frequency of ZDS II. The frequency settings is found at **Project** → **Settings** → **Debugger** → **ZDB: Configure ZDB Driver: Clock Frequency**. For supported frequencies, refer to Z8 Encore! XP® Product Specification .

Power and Communication Interfaces

[Table 1](#) provides jumper information concerning the shunt status, functions, devices and defaults affected by jumpers JP3 and JP4.

Table 1. Jumpers JP3 and JP4

Jumper	Status	Device Affected	Status	Default
JP3**	OUT*	RS-232 interface	Enabled	X
JP3	IN	RS-232 interface	Disabled	
JP4	OUT*	IrDA interface	Enabled	
JP4	IN	IrDA interface	Disabled	X
<p>* These jumpers must not be OUT at the same time. ** If the module is plugged onto an eZ80® Evaluation platform or eZ80 demonstration board the local RS-232 can be disabled by connecting header JP2 pin 50 to the corresponding GND on the mating connector.</p>				

External Interface Headers JP1 and JP2

The external interface headers, JP1 and JP2 contain no connectors when the board is shipped. You can insert 0.1" space connectors of choice.

Schematics

Figure 3 and Figure 4 displays the schematics for Z8 Encore! XP® F0822 Series Evaluation Board.

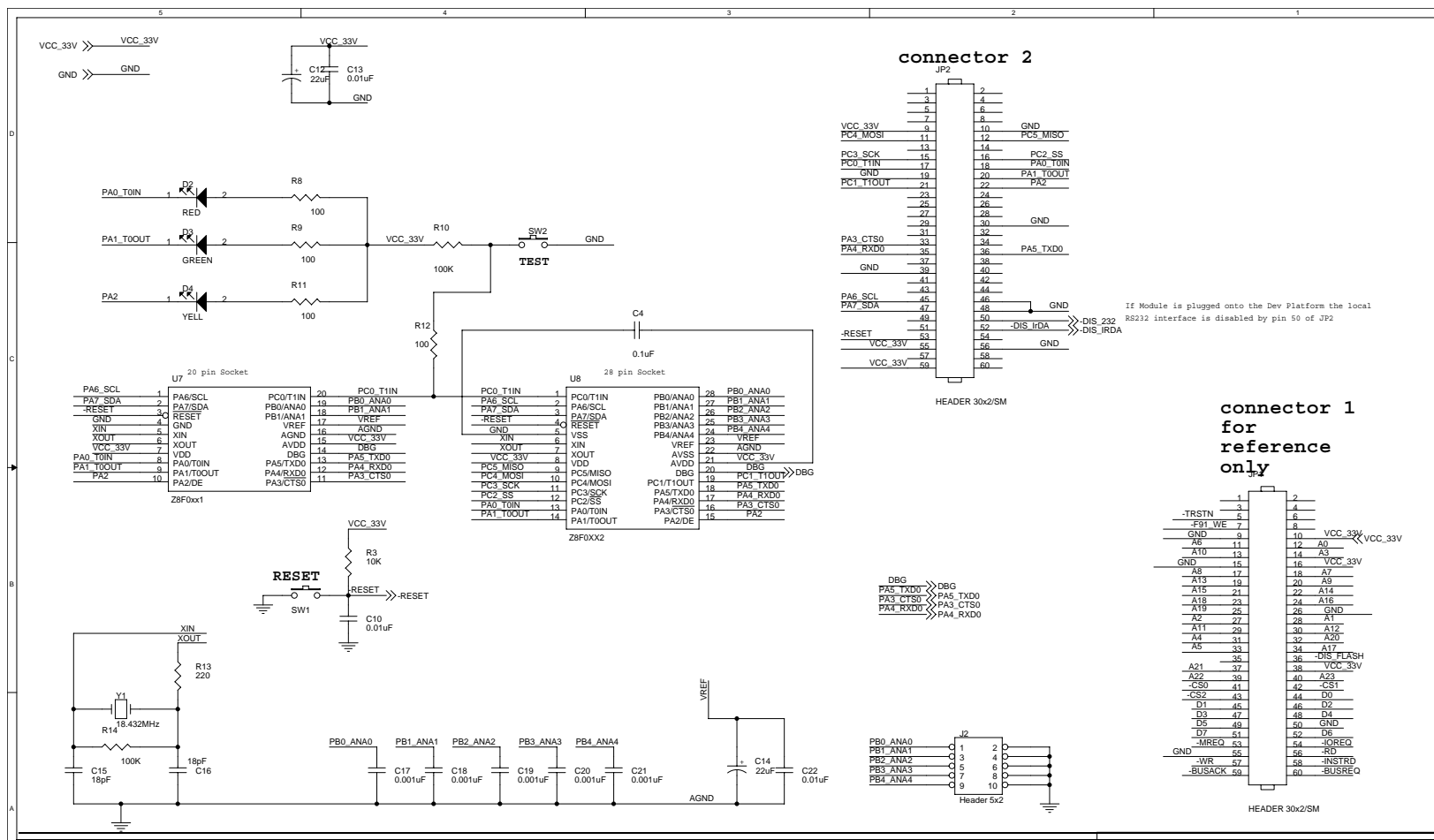

Figure 3. Schematic for Z8 Encore! XP F0822 Series Evaluation Board

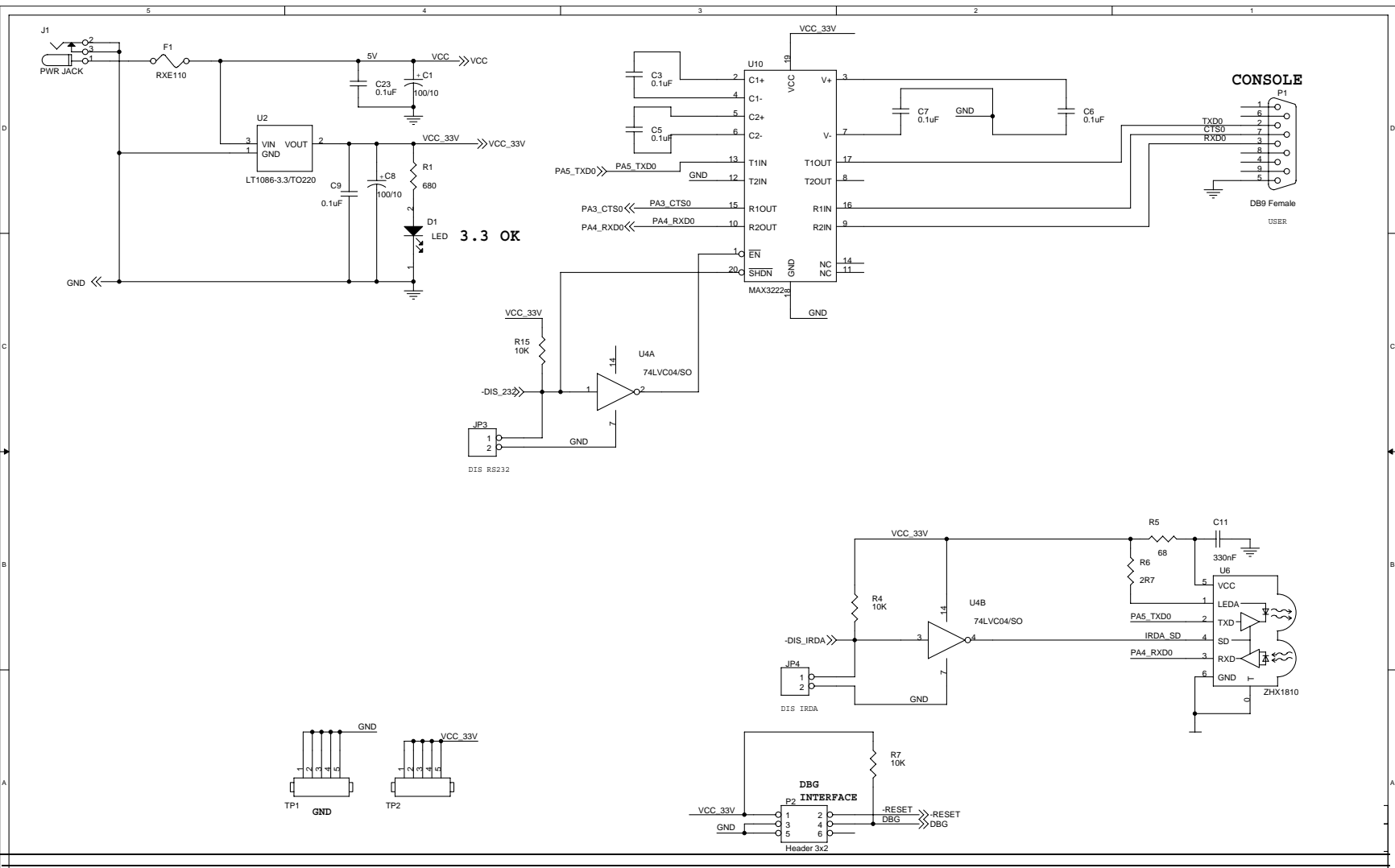

Figure 4. Schematic for Z8 Encore! XP F0822 Series Evaluation Board

Customer Support

For answers to technical questions about the product, documentation, or any other issues with Zilog's offerings, please visit Zilog's Knowledge Base at <http://www.zilog.com/kb>.

For any comments, detail technical questions, or reporting problems, please visit Zilog's Technical Support at <http://support.zilog.com>.



Warning: DO NOT USE IN LIFE SUPPORT

LIFE SUPPORT POLICY

ZILOG'S PRODUCTS ARE NOT AUTHORIZED FOR USE AS CRITICAL COMPONENTS IN LIFE SUPPORT DEVICES OR SYSTEMS WITHOUT THE EXPRESS PRIOR WRITTEN APPROVAL OF THE PRESIDENT AND GENERAL COUNSEL OF ZILOG CORPORATION.

As used herein

Life support devices or systems are devices which (a) are intended for surgical implant into the body, or (b) support or sustain life and whose failure to perform when properly used in accordance with instructions for use provided in the labeling can be reasonably expected to result in a significant injury to the user. A critical component is any component in a life support device or system whose failure to perform can be reasonably expected to cause the failure of the life support device or system or to affect its safety or effectiveness.

Document Disclaimer

©2008 by Zilog, Inc. All rights reserved. Information in this publication concerning the devices, applications, or technology described is intended to suggest possible uses and may be superseded. ZILOG, INC. DOES NOT ASSUME LIABILITY FOR OR PROVIDE A REPRESENTATION OF ACCURACY OF THE INFORMATION, DEVICES, OR TECHNOLOGY DESCRIBED IN THIS DOCUMENT. ZILOG ALSO DOES NOT ASSUME LIABILITY FOR INTELLECTUAL PROPERTY INFRINGEMENT RELATED IN ANY MANNER TO USE OF INFORMATION, DEVICES, OR TECHNOLOGY DESCRIBED HEREIN OR OTHERWISE. The information contained within this document has been verified according to the general principles of electrical and mechanical engineering.

eZ8, Z8, eZ80, Z8 Encore!, and Z8 Encore! XP are trademarks or registered trademarks of Zilog, Inc. All other product or service names are the property of their respective owners.

Mouser Electronics

Authorized Distributor

Click to View Pricing, Inventory, Delivery & Lifecycle Information:

[ZiLOG:](#)

[Z8F08200100KIT](#) [Z8F08200100KITG](#)