

## PSM Series

True RMS 3-Phase Voltage Monitoring Relay



### Description

PSM series is a 3-phase mains monitoring relay. It operates on 3P systems, monitoring phase loss, phase sequence and undervoltage. Power supply provided by the monitored mains. For mounting on DIN-rail.

### Main Features & Benefits

- **Wide Voltage Range:** Working in systems from 208 to 480 VAC.
- **Adjustable Undervoltage Level:** To allow a correct response to real alarm conditions with easy-to-use front dial
- **Output and Status LED Indication:** For quick troubleshooting.
- **Regenerated Voltage Detection:** To detect phase loss even while the motor is running.
- **High Compactness:** 17.5 mm DIN-rail housing.
- **Monitoring:** 3-phase mains with 3 wires (3P).
- **Detection:** Identify the correct phase sequence and phase loss.
- **Changeover Relay Output:** Single-Pole Double-Throw

### Part Numbering System

Code	Option	Description
PSM		Product Series
-	02	DIN Rail Mount
-	A	SPDT Configuration, 17.5 mm Package
-	208	Power Supply: 208 to 240 VAC
-	380	Power Supply: 380 to 480 VAC

Example: **PSM**    **02**    **A**    **208**

Series	DIN-Rail Mount	Configuration	Power Supply
--------	----------------	---------------	--------------

### Structure

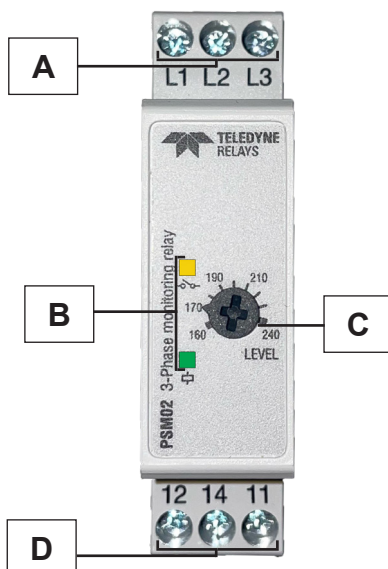

Element	Component	Function
A	Input Terminals	Connection of the line voltages
B	Information LEDs	Yellow for relay output status Green for device ON
C	Voltage setpoint dial	Undervoltage setpoint adjustment
D	Output Terminals	SPDT relay output

## Outline

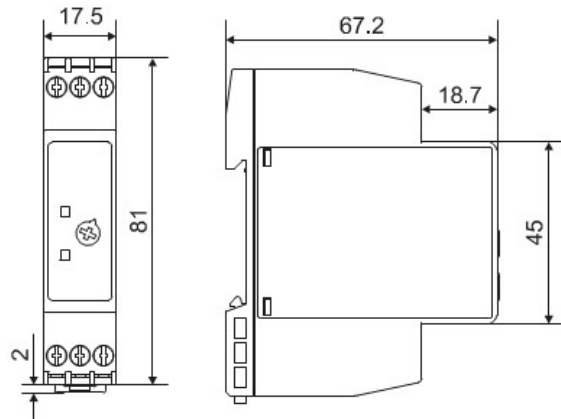

Dimensions in mm

## Power Supply

<b>Power Supply</b>	Supplied by measured phases (L1, L3)	
<b>Oversvoltage Category</b>	III (IEC 60664)	
<b>Voltage Range</b>	<b>PSM02A208</b>	208 to 240 V <sub>L-L</sub> AC ± 15% (177 to 276 V)
	<b>PSM02A380</b>	380 to 480 V <sub>L-L</sub> AC ± 15% (323 to 552 V)
<b>Frequency Range</b>	50 to 60 Hz ±10% sinusoidal waveform	
<b>Consumption</b>	<b>PSM02A208</b>	< 7 VA
	<b>PSM02A380</b>	< 13 VA

## Inputs

<b>Terminals</b>	L1, L2, L3
<b>Measured Variables</b>	Phase Sequence Phase Loss 3P: Voltages V <sub>L12</sub> , V <sub>L23</sub> , V <sub>L31</sub>

## Outputs

<b>Terminals</b>	11, 12, 14
<b>Number of Outputs</b>	1
<b>Type</b>	SPDT electromechanical relay with changeover contacts
<b>Logic</b>	Output de-energized
<b>Contact Rating</b>	<b>I<sub>th</sub></b> : 5 A @ 250 VAC <b>AC15</b> : 2.5 A @ 250 VAC <b>DC12</b> : 5 A @ 24 VDC <b>DC13</b> : 2.5 A @ 24 VDC
<b>Electrical Lifetime</b>	≥ 50 x 10 <sup>3</sup> operations (at 5 A, 250 V, cos φ = 1)
<b>Mechanical Lifetime</b>	> 30 x 10 <sup>6</sup> operations
<b>Assignment</b>	Associated to all alarm types

## Insulation

<b>Terminals</b>	Basic Insulation
<b>Inputs: L1, L2, L3 to Output: 11, 12, 14</b>	2.5 kVrms, 4 kV impulse 1.2/50 µs

## General

<b>Material</b>	Polyamide (Nylon) (PA66/6) or Phenylene ether + Polystyrene (PPE-PS) Flammability rating: HB according to UL 94
<b>Colour</b>	RAL7035 (Light Grey)
<b>Dimensions (W x H x D)</b>	17.5 x 81 x 67.2 mm (0.68 x 3.19 x 2.65 in)
<b>Weight</b>	75 g (2.65 oz)
<b>Terminals</b>	Cable size from 0.05 to 2.5 mm <sup>2</sup> (AWG30 to AWG13), stranded or solid
<b>Tightening Torque</b>	Max. 0.5 Nm (4.425 lbin)
<b>Terminal Type</b>	Screw terminals

## Environmental

<b>Operating Temperature</b>	50 Hz: -20 to 60°C (-4 to 140°F) 60 Hz: -20 to 50°C (-4 to 122°F)
<b>Storage Temperature</b>	-30 to 80°C (-22 to 176°F)
<b>Relative Humidity</b>	5 - 95% Non-condensing
<b>Protection Degree</b>	IP20
<b>Pollution Degree</b>	2
<b>Operating Max Altitude</b>	2000 m amsl (6560 ft)
<b>Salinity</b>	Non saline environment
<b>UV Resistance</b>	No





Test Condition	Test	Level
<b>Tests with Unpacked Device</b>	Vibration response (IEC60255-21-1)	Class 1
	Vibration endurance (IEC 60255-21-1)	Class 1
	Shock (IEC 60255-21-2)	Class 1
	Bump (IEC 60255-21-2)	Class 1

Test Condition	Test	Level
<b>Tests with packed Device</b>	Vibration random (IEC60068-2-64)	Class 1
	Shock (IEC 60255-21-2)	Class 1
	Bump (IEC 60255-21-2)	Class 1

Class 1: monitoring devices for normal use in power plants, substations and industrial plants and for normal transportation conditions.

The packaging type is designed and implemented in such manner that the severity class parameters will not be exceeded during transportation.

## Compatibility and Conformity

Marking	 
Directives	2014/35/EU (LVD - Low voltage) 2014/30/EU (EMC - Electromagnetic compatibility)
Standards	Insulation coordination: EN 60664-1 Immunity: EN61000-6-2 Emission: EN61000-6-3
Approvals	  

## Operating Description

### Device configuration

The relay operates when all the phases are present, the phase sequence is correct and the phase-phase voltage levels are above the adjusted setpoint.



Undervoltage Adjustment Dial		
Typology	PSM02A208	Linear selection from 160 to 240 V
	PSM02A380	Linear selection from 320 to 480 V
Resolution	PSM02A208	10 V increase per notch
	PSM02A380	20 V increase per notch
Function		Undervoltage setpoint

Phase Loss Alarm		
Input Variables		L1-L2, L2-L3 and L3-L1
Alarm Setpoint		One phase $\leq$ 85% of the rated value (regenerated voltage detection)
Restore Setpoint		All phases $>$ 85% of the rated value + Hysteresis
Reaction Time		Alarm ON : $<$ 100 ms Alarm OFF : $<$ 300 ms
Hysteresis	PSM02A208	3% on full scale
	PSM02A380	4% on full scale
Delay ON		None
Delay OFF		None

Phase Sequence Alarm		
Input Variables		Connection L1, L2, L3
Reaction Time		Alarm ON : $<$ 100 ms Alarm OFF : $<$ 300 ms
Delay ON		None
Delay OFF		None

Undervoltage Alarm		
Input Variables		3P: voltages $V_{L12}$ , $V_{L23}$ , $V_{L31}$
Reaction Time		Alarm ON : < 100 ms Alarm OFF : < 300 ms
Undervoltage Setting Range	PSM02A208	From 160 to 240 VAC
	PSM02A380	From 320 to 480 VAC
Repeatability		0.5% on full scale
Hysteresis	PSM02A208	3% on full scale
	PSM02A380	4% on full scale
Delay ON		None
Delay OFF		None

### Information LEDs

Color	Status		Description
Green (  )	Power Supply	ON	Power Supply ON
		OFF	Power Supply OFF
Yellow (  )	Relay Output	ON	Energized
		OFF	De-energized

### Operating Diagram

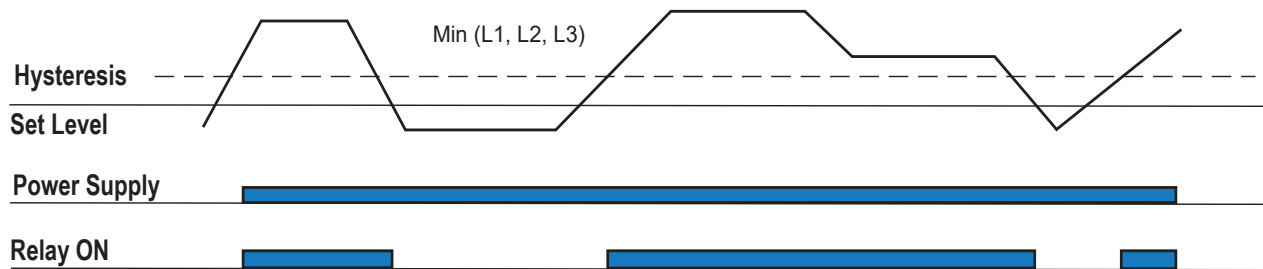

Fig. 1 Undervoltage Monitoring

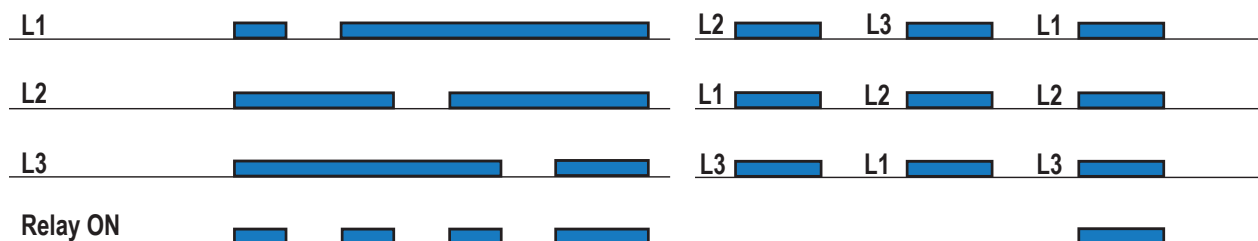
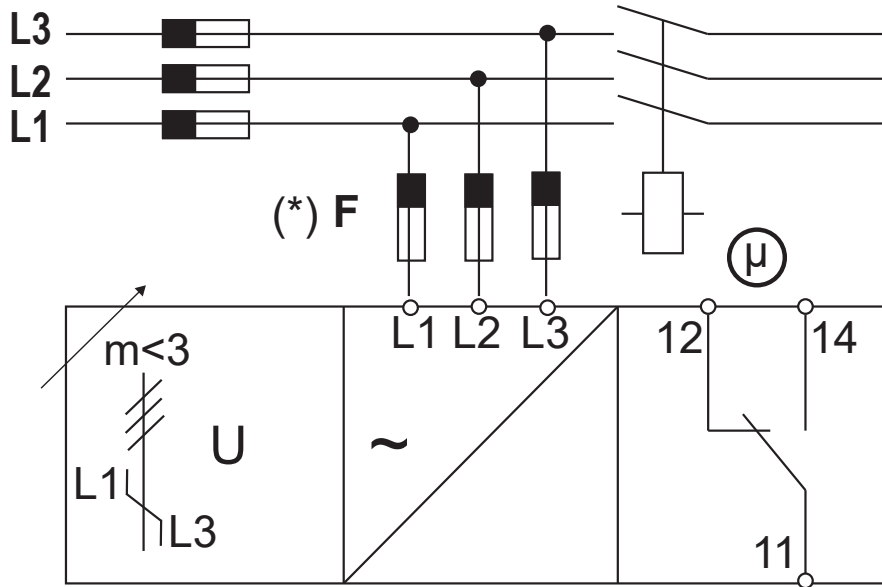

Fig 2. Total Phase Loss, Phase Sequence

**Connection Diagram**



(\*) NOTE: fuses F of 315 mA delayed, if required by local law.

Questions? Scan the QR code to submit your inquiry



# Mouser Electronics

Authorized Distributor

Click to View Pricing, Inventory, Delivery & Lifecycle Information:

[Teledyne Relays:](#)

[PSM02A208](#) [PSM02A380](#)