

# E3PC

## Three-Phase, Zero Cross Solid State Relays

### Description

The **E3PC** series is engineered to effortlessly manage diverse loads like heating elements, motors, and transformers. Capable of handling voltages of up to 600 VACrms, this relay incorporates a built-in varistor to ensure robust transient protection, making it suitable for demanding industrial applications.

Enhancing reliability and load cycle capacity, three semiconductor power units are directly soldered onto the direct copper bonded (DCB) substrate. This SSR series offers both AC and DC-controlled versions, accompanied by a built-in LED status indicator for monitoring the applied control voltage and an optional overtemperature alarm.

Spanning a range of load currents reaching up to 75 AACrms, this series caters to various power requirements with efficiency and durability.



### Main Features

- 3-phase Solid State Relay
- Zero switching
- Rated operational current: 3 x 25, 55 or 75 A
- Rated operational voltage: Up to 690 VAC
- Control voltage, 4-32 VDC or 24-275 VAC
- Integral snubber network
- Built-in varistor
- Over-temperature protection option with alarm output
- IP 20 back-of-hand protection
- LED indication of control input and over-temperature alarm status

### Applications

- Plastic extrusion machines
- Thermoforming machines
- Coffee machines
- Electrical ovens
- Vending machines
- Soldering ovens
- Dryers
- Climatic chambers
- IR handling units
- Plastic sealing machines
- Shrink tunnels, etc.

### Part Numbering System

Code	Option	Description
<b>E3PC</b>		Product Series
-	<b>40</b>	Operational Voltage Range: 24-440 VAC
-	<b>60</b>	Operational Voltage Range: 42-660 VAC
-	<b>D</b>	Control voltage: 4-32 VDC
-	<b>A</b>	Control voltage: 24-275 VAC, 24-50 VDC
-	<b>25</b>	25A Rated Load Current
-	<b>55</b>	55A Rated Load Current
-	<b>75</b>	75A Rated Load Current

Example: **E3PC 60 D 55**



## Performance

### Mains Supply

	E3PC40..	E3PC60..
Operational Voltage Range	24-440 VAC	42-660 VAC
Operational Frequency Range	45 to 65 Hz	
Blocking Voltage	800 Vp	1600 Vp
Overvoltage Category	III	

### Input Specifications

	E3PC..D..	E3PC..A..
Control Voltage	4-32 VDC	24-275 VAC/24-50 VDC
Pick-Up Voltage	3.8 VDC	18 VAC/20 VDC
Drop-Out Voltage	1.2 VDC	9 VAC/DC
Input Current	≤ 23 mA	≤ 15 mA
Response Time Pick-Up Power Output = 50 Hz	10 ms	20 ms
Response Time Drop-Out Power Output = 50 Hz	10 ms	30 ms

### Output Specifications

	E3PC..25..	E3PC..55..	E3PC..75..
Rated Operational Current AC 51 @ T <sub>a</sub> = 25°C AC 53a @ T <sub>a</sub> = 25°C	25 Arms	55 Arms	75 Arms
	5 Arms	15 Arms	20 Arms
Min. Operational Load Current	150 mArms	250 mArms	400 mArms
Rep. Overload Current t=1 s	37 Arms	< 125 Arms	< 150 Arms
Non-rep. Surge Current t=10 ms	325 Ap	600 Ap	1150 Ap
Off-State Leakage Current	< 3 mArms		
I <sup>2</sup> t for Fusing t=10 ms	525 A <sup>2</sup> s	1800 A <sup>2</sup> s	6600 A <sup>2</sup> s
Critical dV/dt Off State min.	≥ 500 V/μs		
On-State Voltage Drop	< 1.6 Vrms		

### Thermal Data

Operating Temperature	-30° to +80°C (-22° to +176° F)
Storage Temperature	-40° to +100°C (-40° to + 212° F)
Maximum Junction Temperature	+125°C (+ 257°F)

## General Specifications

<b>Housing Material</b>	Noryl, black
<b>Potting Material</b>	Polyurethane
<b>Base Plate</b>	25, 55A: aluminum, nickel-plated 75A: copper, nickel-plated
<b>Pollution Degree</b>	3
<b>Rated Isolation Voltage</b>	Input to output: 4000 VACrms Output to case: 4000 VACrms
<b>Weight</b>	Approx. 380 g

## Dimensions

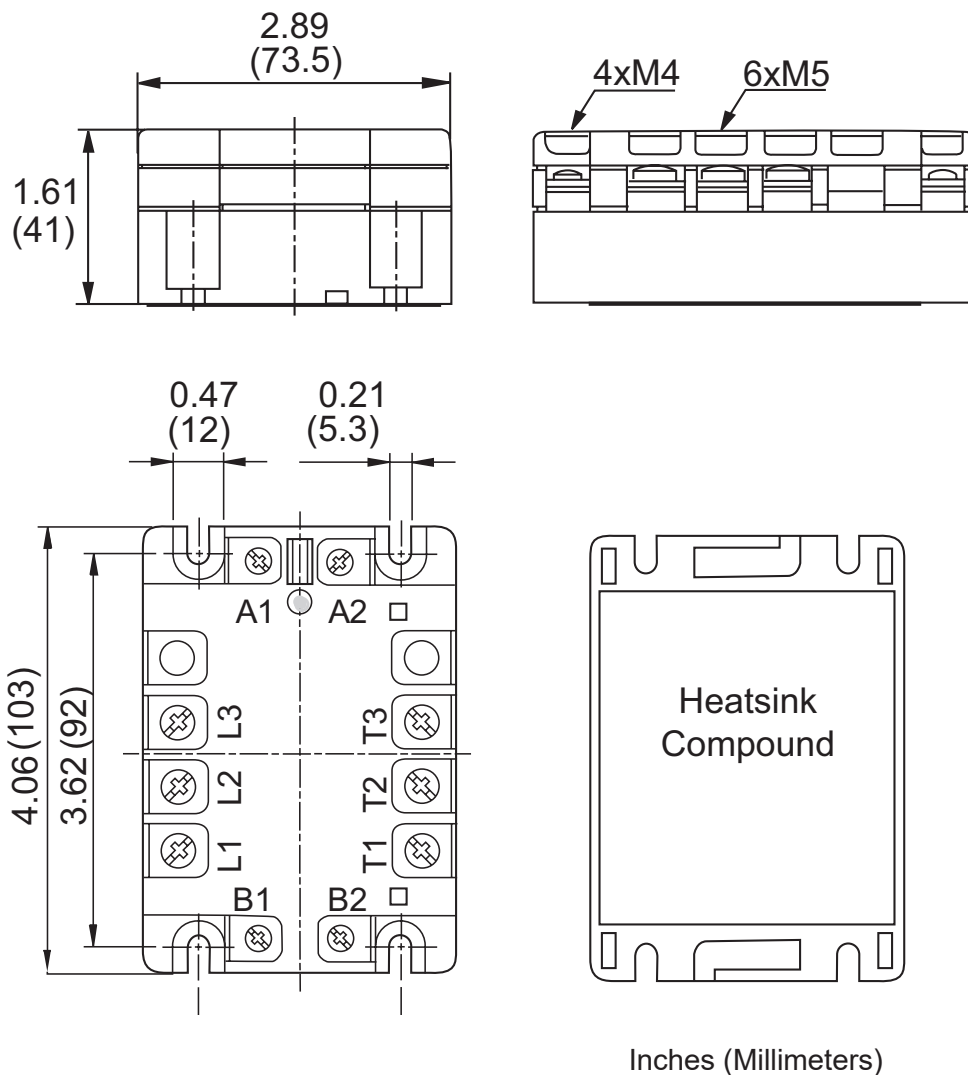

○ Relay On LED

## Connection Diagrams

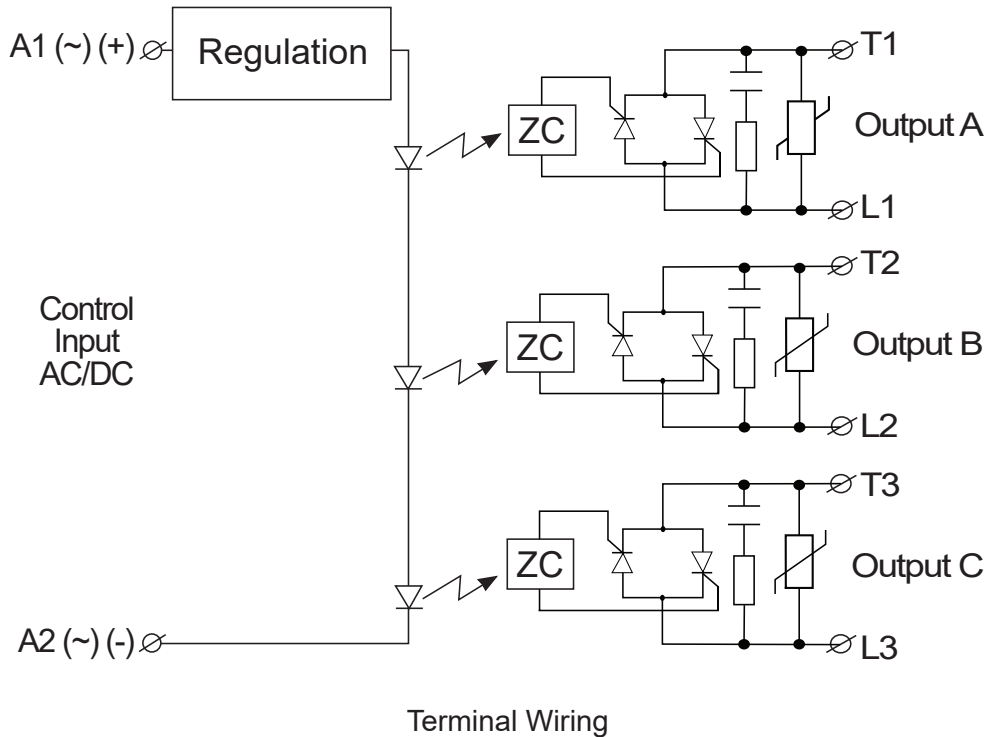

## Connection Specifications

Relay	
Mounting screws	M5
Mounting torque	≤ 1.5 Nm
Control Terminal	
Mounting screws	M4
Mounting torque	≤ 0.5 Nm
Wire size	Max: 2 x 2.5 mm <sup>2</sup> (AWG14) Min: 2 x 1 mm <sup>2</sup>
Power Terminal	
Mounting screws	M5
Mounting torque	2.5 Nm
Wire size	Max: 2 x 6 mm <sup>2</sup> (AWG8) Min: 2 x 1 mm <sup>2</sup>

## Heatsink Selection

Thermal Resistance (°C/W) of E3PC..25

Load Current (A)	Ambient Temp. (°C)							Power Dissipation (W)
	20	30	40	50	60	70	80	
25.0	0.44	0.34	0.23	0.12	0.01	-	-	92
22.5	0.62	0.49	0.37	0.24	0.12	-	-	80
20.0	0.84	0.69	0.54	0.40	0.25	0.10	-	68
17.5	1.12	0.95	0.78	0.60	0.43	0.25	0.08	58
15.0	1.51	1.30	1.09	0.88	0.67	0.46	0.25	47
12.5	2.06	1.80	1.54	1.27	1.01	0.75	0.48	38
10.0	2.75	2.40	2.06	1.72	1.37	1.03	0.69	29
7.5	3.83	3.35	2.87	2.39	1.91	1.43	0.96	21
5.0	6.01	5.26	4.51	3.76	3.01	2.25	1.50	13
2.5	12.62	11.04	9.46	7.89	6.31	4.73	3.15	6

Thermal Resistance (°C/W) of E3PC..55

Load Current (A)	Ambient Temp. (°C)							Power Dissipation (W)
	20	30	40	50	60	70	80	
55.0	0.29	0.23	0.17	0.11	0.05	-	-	164
50.0	0.36	0.29	0.22	0.16	0.09	0.02	-	148
45.0	0.44	0.36	0.29	0.21	0.14	0.06	-	133
40.0	0.54	0.46	0.37	0.29	0.20	0.12	0.03	118
35.0	0.67	0.58	0.48	0.38	0.28	0.19	0.09	103
30.0	0.85	0.74	0.62	0.51	0.39	0.28	0.16	87
25.0	1.10	0.96	0.82	0.68	0.55	0.41	0.27	73
20.0	1.38	1.21	1.04	0.87	0.69	0.52	0.35	58
15.0	1.85	1.62	1.39	1.16	0.93	0.70	0.46	43
10.0	2.80	2.45	2.10	1.75	1.40	1.05	0.70	29
5.0	5.62	4.92	4.21	3.51	2.81	2.11	1.40	14
2.5	11.26	9.85	8.45	7.04	5.63	4.22	2.82	7

Thermal Resistance (°C/W) of E3PC..75

Load Current (A)	Ambient Temp. (°C)							Power Dissipation (W)
	20	30	40	50	60	70	80	
75.0	0.27	0.22	0.17	0.12	0.07	0.02	-	201
70.0	0.32	0.27	0.21	0.16	0.10	0.05	-	184
65.0	0.38	0.32	0.26	0.20	0.14	0.08	0.02	167
60.0	0.44	0.38	0.31	0.25	0.18	0.11	0.05	151
55.0	0.52	0.45	0.38	0.30	0.23	0.16	0.08	136
50.0	0.62	0.54	0.45	0.37	0.29	0.21	0.12	121
45.0	0.74	0.64	0.55	0.46	0.36	0.27	0.17	106
40.0	0.87	0.76	0.65	0.54	0.43	0.32	0.22	92
35.0	1.01	0.89	0.76	0.63	0.51	0.38	0.25	79
30.0	1.21	1.06	0.91	0.76	0.60	0.45	0.30	66
25.0	1.49	1.30	1.11	0.93	0.74	0.56	0.37	54
20.0	1.90	1.67	1.43	1.19	0.95	0.71	0.48	42
15.0	2.60	2.28	1.95	1.63	1.30	0.98	0.65	31
10.0	4.01	3.51	3.01	2.51	2.01	1.50	1.00	20
5.0	8.24	7.21	6.18	5.15	4.12	3.09	2.06	10

## Compatibility and Conformity

Approvals*	    
------------	--

Electromagnetic Compatibility (EMC) - Immunity	
<b>Electrostatic Discharge (ESD)</b>	EN 61000-4-2 8 kV air discharge, 4 kV contact (PC2)
<b>Radiated Radio Frequency</b>	EN 61000-4-3 10 V/m, from 80 MHz to 1 GHz (PC1) 10 V/m, from 1.4 to 2 GHz (PC1) 3 V/m, from 2 to 2.7 GHz (PC1)
<b>Electrical Fast Transient (burst)</b>	EN 61000-4-4 Output: 2 kV, 5 kHz (PC1) Input: 1 kV, 5 kHz (PC1)
<b>Conducted Radio Frequency</b>	EN 61000-4-6 10V/m, from 0.15 to 80 MHz (PC1)
<b>Electrical Surge</b>	EN 61000-4-5 Output, line to line: 1 kV (PC1) Output, line to earth: 2 kV (PC1) Input, line to earth: 1 kV (PC1)
<b>Voltage Dips</b>	EN 61000-4-11 0% for 0.5, 1 cycle (PC2) 40% for 10 cycles (PC2) 70% for 25 cycles (PC2)
<b>Voltage Interruptions</b>	EN 61000-4-11 0% for 5000ms (PC2)

Electromagnetic Compatibility (EMC) - Emissions	
<b>Radio Interference Field Emission (Radiated)</b>	EN 55011 Class A: from 30 to 1000 MHz
<b>Radio Interference Voltage Emissions (Conducted)</b>	From 0.15 to 30 MHz EN 55011 Class A (industrial) with filters

\*CSA approval for 75 A models (E3PC..75.) is limited to 65 A @ 40°C.

Note:

- Performance Criteria 1 (PC1): no degradation of performance or loss of function is allowed when the product is operated as intended.
- Performance Criteria 2 (PC2): during the test, degradation of performance or partial loss of function is allowed. However when the test is complete the product should return operating as intended by itself.
- Performance Criteria 3 (PC3): temporary loss of function is allowed, provided the function can be restored by manual operation of the controls.
- Control input lines must be installed together to maintain products' susceptibility to Radio Frequency interference.

## Environmental Specifications

<b>EU RoHS Compliant</b>	Yes
<b>China RoHS</b>	

The declaration in this section is prepared in compliance with People's Republic of China Electronic Industry Standard SJ/T11364-2014: Marking for the Restricted Use of Hazardous Substances in Electronic and Electrical Products.

Part Name	Toxic or Harardous Substances and Elements					
	Lead (Pb)	Mercury (Hg)	Cadmium (Cd)	Hexavalent Chromium (Cr(VI))	Polybrominated biphenyls (PBB)	Polybrominated diphenyl ethers (PBDE)
Power Unit Assembly	x	0	0	0	0	0

O: Indicates that said hazardous substance contained in homogeneous materials for this part are below the limit requirement of GB/T 26572.

X: Indicates that said hazardous substance contained in one of the homogeneous materials used for this part is above the limit requirement of GB/T 26572.

## Short Circuit Protection

Protection Co-ordination, Type 1 vs Type 2:

Type 1 protection implies that after a short circuit, the device under test will no longer be in a functioning state. In type 2 coordination, the device under test will still be functional after the short circuit. In both cases, however the short circuit has to be interrupted. The fuse between enclosure and supply shall not open. The door or cover of the enclosure shall not be blown open. There shall be no damage to conductors or terminals and the conductors shall not separate from terminals. There shall be no breakage or cracking of insulating bases to the extent that the integrity of the mounting of live parts is impaired. Discharge of parts or any risk of fire shall not occur.

The product variants listed in the table hereunder are suitable for use on a circuit capable of delivering not more than 65,000 Arms Symmetrical Amperes 600 Volts maximum when protected by fuses. Tests at 65,000 A were performed with Class J fuses, fast acting; please refer to the table below for maximum allowed ampere rating of the fuse. Use fuses only.

Tests with Class J fuses are representative of Class CC fuses.

Protection co-ordination Type 1 according to UL 508				
Part No.	Prospective Short Circuit Current (kArms)	Max Fuse Size (A)	Class	Voltage (VAC)
E3PC...25	65	30	CC	600
E3PC...55		50	J	
E3PC...75		30	CC	
E3PC...75		70	J	

Protection co-ordination Type 2 for fuses						
Part No.	Prospective Short Circuit Current (kArms)	Ferraz Shawmut (Mersen)				
		Max Fuse Size (A)	Part Number	Fuse Size (mm)	Fuse Holder Type	Voltage [VAC]
E3PC...25	65	25	6.9 gRB 10-25	10.3 x 38	CMS10 3P	400
		20	6.9 gRB 10-20	10.3 x 38	CMS10 3P	600
E3PC...55	65	50	6.9xx CP gRC 14 x 51/50	14 x 51	CMS14 3P	400
		50	6.9xx CP gRC 22 x 58/50	22 x 58	CMS22 3P	600
E3PC...75	65	63	6.9xx CP gRC 14 x 58/63	22 x 58	CMS22 3P	400
		63	6.9xx CP gRC 22 x 58/63	22 x 58	CMS22 3P	600

Protection co-ordination Type 2 with Minature Circuit Breakers (M.C.B.s)				
Solid State Relay Type	ABB Model no. for Z - Type M. C. B. (Rated Current)	ABB Model no. for B - Type M. C. B. (Rated Current)	Wire Cross Sectional Area (mm <sup>2</sup> )	Minimum Length of Cu Wire Conductor (m) <sup>1</sup>
E3PC..25	S203 - Z4 (4 A) S203 - Z6 UC (6 A)	S203 - B2 (2 A) S203 - B2 (2 A)	1.0	21.0
			1.0	21.0
			1.5	31.5
E3PC..55	S203 - Z10 (10 A)	S203 - B4 (4 A)	1.0	7.6
			1.5	11.4
			2.5	19.0
	S203 - Z16 (16 A)	S203 - B6 (6 A)	1.0	5.2
			1.5	7.8
			2.5	13.0
			4.0	20.8
	S203 - Z20 (20 A)	S203 - B10 (10A)	1.5	12.6
			2.5	21.0
	S203 - Z25 (25 A)	S203 - B13 (13 A)	2.5	25.0
			4.0	40.0
	E3PC..75	S203 - Z20 (20 A)	S203 - B10 (10 A)	1.5
2.5				7.0
4.0				11.2
S203 - Z32 (32 A)		S203 - B16 (16 A)	2.5	13
			4.0	20.8
			6.0	31.2

1. Between MCB and Load (including return path which goes back to the mains)

Note: A prospective current of 6 kA and a 230 / 400 V power supply is assumed for the above suggested specifications. For cables with different cross section than those mentioned above please consult Teledyne Relays' Technical Support Group.



Scan the QR code to be  
routed to our contact us page



# Mouser Electronics

Authorized Distributor

Click to View Pricing, Inventory, Delivery & Lifecycle Information:

[Teledyne Relays:](#)

[E3PC60D55](#) [E3PC60D25](#)