

THIS DOCUMENT IS THE PROPERTY OF
KEYSTONE ELECTRONICS CORP. AND
SHALL NOT BE REPRODUCED, DISTRIBUTED
OR USED AS A BASIS FOR MANUFACTURE
WITHOUT PRIOR WRITTEN PERMISSION
FROM KEYSTONE ELECTRONICS CORP.

ACTUAL SIZE

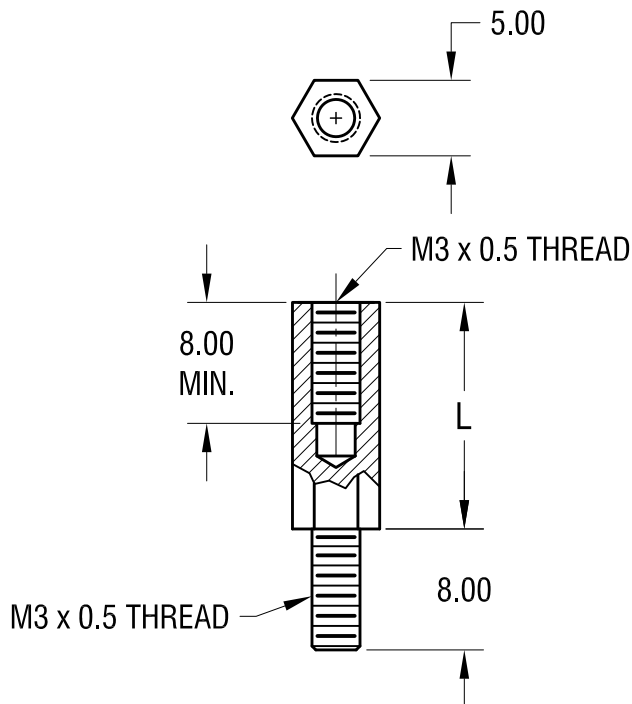

PART NO.	'L' DIM.
25501	10.00
25502	12.00
25503	15.00
25504	18.00
25505	20.00
25506	25.00

NOTE:

1. ALL DIMENSIONS ARE IN MILLIMETERS

KEYSTONE ELECTRONICS CORP.

www.keyelco.com • NEW HYDE PARK NY 11040 • Tel (516)328-7500

PART NAME

5mm M/F/ HEX STANDOFF

MATERIAL

NYLON 6/6

FINISH

NONE

DRN BY

BOONE

DATE

7.18.06

APP'D

RH

SCALE

2X

TOLERANCES

INCH

[MM]

CODE

DWG NO.

DECIMAL

±

[± 0.40]

C

ANGULAR ± 1°

UNLESS OTHERWISE SPECIFIED

25501 - 25506

DATE	DESCRIPTION	REV.

Mouser Electronics

Authorized Distributor

Click to View Pricing, Inventory, Delivery & Lifecycle Information:

[Keystone Electronics:](#)

[25506](#)