

# SiC- JFET

Silicon Carbide- Junction Field Effect Transistor

# CoolSiC™

1200 V CoolSiC™ Power Transistor  
IJW120R100T1

## Final Datasheet

Rev. 2.0, <2013-09-11>

## 1200 V Silicon Carbide JFET

### Description

CoolSiC™ is Infineon's new family of active power switches based on silicon carbide. Combining the excellent material properties of silicon carbide with our normally-on JFET concept allows the next steps towards higher performance paired with very high ruggedness. The extremely low switching and conduction losses make applications even more efficient, compact, lighter and cooler.

### Features

- Ultra fast switching
- Internal fast body diode
- Low intrinsic capacitance
- Low gate charge
- 175 °C maximum operating temperature

### Benefits

- Enabling higher system efficiency and/ or higher output power in same housing
- Enabling higher frequency / increased power density solutions
- System cost / space savings due to reduced cooling requirements
- Higher system reliability due to enlarged junction temperatures rates
- Reduced EMI

### Applications

- Solar Inverters
- High voltage DC/ DC or AC/ DC conversion
- Bidirectional Inverter
- Compliant for applications according to climate class IEC 60721-3-4 (4K4H)

## IJW120R100T1

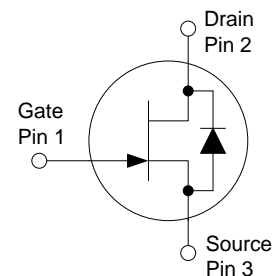
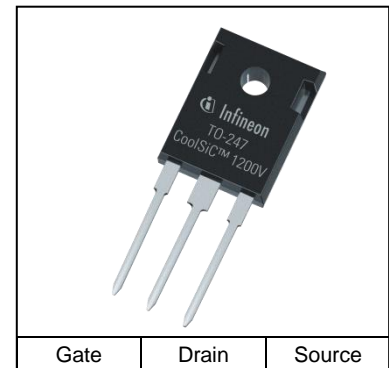

**Table 1 Key Performance Parameters**

Parameter	Value	Unit
$V_{DS}$	1200	V
$R_{DS(on) max}$	100	mΩ
$Q_{G, typ}$	72	nC
$I_{D, pulse}$	78	A
$E_{oss} @ 800 V$	28	μJ

**Table 2 Pin Definition**

Pin 1	Pin 2	Pin 3
Gate	Drain	Source

Type / ordering Code	Package	Marking	Related links
IJW120R100T1 <sup>1)</sup>	PG-TO247-3	120R100T1	<a href="http://www.infineon.com/CoolSiC">www.infineon.com/CoolSiC</a>

1) J-STD20 and JESD22

## Table of Contents

Description .....	2
<b>1 Application considerations .....</b>	<b>4</b>
1.1 Introduction.....	4
1.2 Driver circuit .....	4
1.3 Device characteristics .....	5
1.3.1 Gate voltage window .....	5
1.3.2 Controllability .....	5
1.3.3 Reverse biased behavior .....	6
1.3.4 Short circuit ruggedness .....	6
1.3.5 Switching and conduction losses .....	6
1.4 Environmental Conditions .....	6
<b>2 Maximum ratings.....</b>	<b>7</b>
<b>3 Thermal characteristics.....</b>	<b>8</b>
<b>4 Electrical characteristics.....</b>	<b>8</b>
<b>5 Electrical characteristics diagrams.....</b>	<b>10</b>
<b>6 Test circuits .....</b>	<b>17</b>
<b>7 Package outlines .....</b>	<b>18</b>
<b>8 Revision History .....</b>	<b>19</b>

# 1 Application considerations

## 1.1 Introduction

Wide bandgap semiconductors are very attractive as a basematerial for power devices due to low losses, improved temperature capability and high thermal conductivity. Infineon’s silicon carbide schottky diodes have been commercially available on the market for many years. The material and technology knowhow has been used to create new active switches based on silicon carbide providing significant improvement in the value proposition in comparison to known devices such as:

- Resistive forward characteristic in first and third quadrant
- Monolithic integrated body diode, in switching performance very close to SiC schottky barrier diodes
- Very fast and controllable switching transients
- Very low capacitances and gate charge

These benefits result in higher system efficiency, allow higher switching frequencies, increased power density and reduced cooling efforts. Due to the normally-on JFET concept any reliability-relevant issues from gate oxides on SiC are completely avoided. To allow the use of this normally-on concept in voltage-source-inverter configurations we propose the following driver circuit.

## 1.2 Driver circuit

Being a normally-on device, the JFET is in its on-state at zero gate voltage and will go into the off-state at negative gate voltage. The normally off behavior can be easily realized by implementing a cascode configuration with a low voltage MOSFET as shown in Figure 1 (*state of the art cascode*). At e.g. startup, the LV MOSFET is in the off-state pushing the source of the JFET to positive potential relative to its gate and keeping the JFET hence in the off-state.

In this conventional cascode, the LV MOSFET will be switched on and off together with the JFET in each switching cycle. This approach has two major drawbacks: firstly, at turn-on additional switching losses will occur as the output capacitance of the LV MOSFET needs to be charged from the positive rail voltage, secondly the combination allows no direct control of the JFET due to the absence of a (JFET) - Drain- to- (LV MOS) - Gate capacitance. These drawbacks can be avoided with the proposed “direct drive” approach. Here, the JFET is directly switched on and off by applying a negative gate voltage and 0V respectively, whereas the series connected LV MOSFET is always in its on- state. The LV MOSFET is turned off only during start- up and e.g. emergency cases such as loss of auxiliary power supply. This solution represents the best match between performance and safety requirements. The driving scheme with a dedicated driver is shown in Fig. 2 (*direct drive technology with 1EDI30J12Cx*).

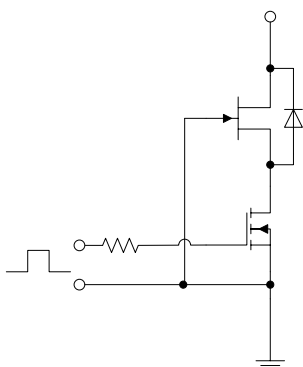

Figure 1: state of the art cascode

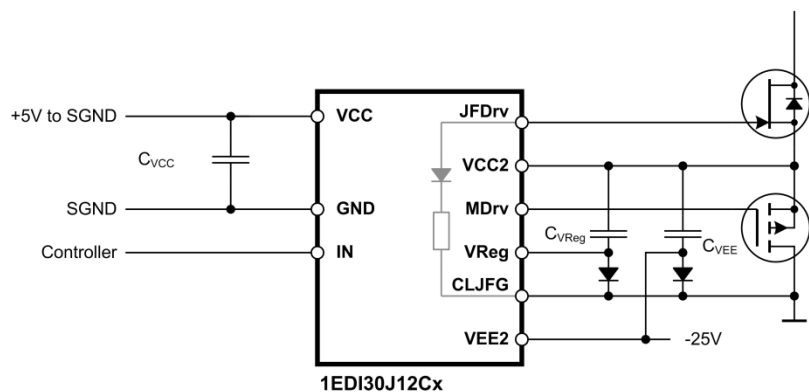

Figure 2: direct drive technology with 1EDI30J12Cx

### 1.3 Device characteristics

#### 1.3.1 Gate voltage window

The gate electrode of the JFET shows, in contrary to isolated MOSFET concepts, a bipolar pn-junction like characteristic: it get's forward biased at around +2.5 V, hence a bipolar current will flow into the gate once the gate- to- source voltage exceeds 2.5 V. This is uncritical and may be used to turn-on the device faster than with the recommended 0 V turn-on. At 25 °C the threshold voltage of the channel can vary between -12 V and -15 V (Figure 3:  $V_{GS(th)}=f(T_j)$  parameter:  $I_{DSS}$ ). The products will be delivered within three groups (bin1, bin2, bin3) of 1 V range each. For paralleling, it is only allowed to parallel devices from the same bin. The use of devices from different bins for paralleling leads to different thermal device behavior. At a voltage of around -23 V the gate- to- source junction enters reverse breakdown, which leads to a temperature dependend bipolar current flow across the junction. In pure voltage driven turn-on and turn-off the lower gate voltage should stay within the window between the pinch-off (threshold) and the punch-through (increased leakage) voltage. For fast and safe turn-off it is strongly recommended to move the lower gate voltage level as close as possible to the punch-through threshold.

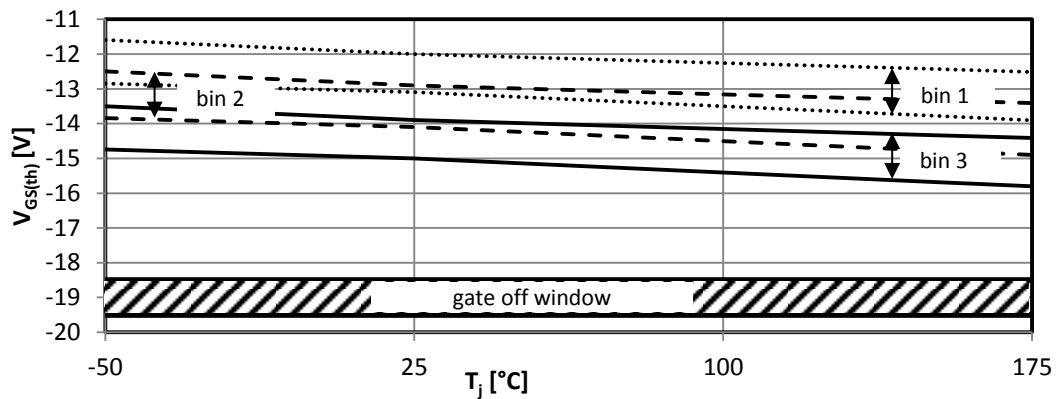

Figure 3:  $V_{GS(th)}=f(T_j)$  parameter:  $I_{DSS}=10 \mu A$

#### 1.3.2 Controllability

The JFET can be well controlled through its miller plateau with an external gate resistor (Figure 4:  $dV_{off}/dt=f(I_{DS})$ ,  $dV_{on}/dt=f(I_{DS})$ ,  $dI_{off}/dt=f(I_{DS})$ ,  $dI_{on}/dt=f(I_{DS})$  parameter:  $T_j=25^\circ C$ ,  $R_{G,external}$ ). Especially  $dI/dt$  is saturating at high current levels. This helps to avoid voltage overshoots in peak current conditions. It is strongly recommended to use very low turn-off gate resistors (down to zero Ohm external gate resistor) to achieve maximum performance from the device as well as to avoid any parasitic  $dV/dt$  or  $dI/dt$  coupled turn-on effects. As shown in the maximum rating division of the datasheet the external gate loop resistance should be lower than 5.1  $\Omega$ .

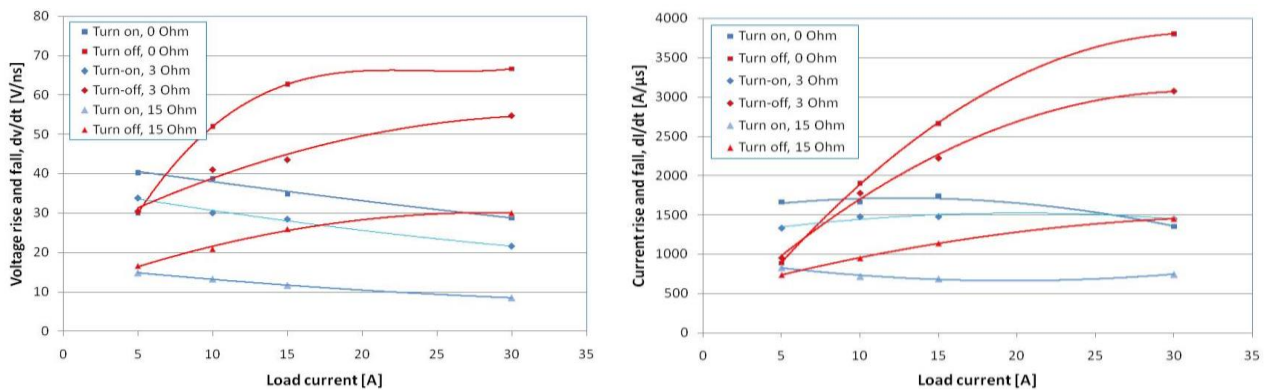

Figure 4:  $dV_{off}/dt=f(I_{DS})$ ,  $dV_{on}/dt=f(I_{DS})$ ,  $dI_{off}/dt=f(I_{DS})$ ,  $dI_{on}/dt=f(I_{DS})$  parameter:  $T_j=25^\circ C$ ,  $R_{G,external}$

### 1.3.3 Reverse biased behavior

The monolithically integrated body diode shows a switching performance close to that of an external SiC schottky barrier diodes, renowned for their zero reverse recovery characteristic. Figure 5 (reverse recovery characteristic  $I_{SD}= 2\text{ A}$  left and  $I_{SD}= 10\text{ A}$ ;  $T_f= 150\text{ }^\circ\text{C}$ ;  $V_{bulk}=400\text{ V}$ ;  $R_{G, external} = (T1) 3.3\ \Omega$ , (T2)  $10\ \Omega$ ) shows the reverse recovery characteristic of the monolithic integrated body diode of the JFET. The reverse recovery charge is load current independent. To avoid any additional losses during hard commutation of the body diode, it is recommended to couple the gate of the switch (acting as diode) with a very low external gate resistor to the gate driver.

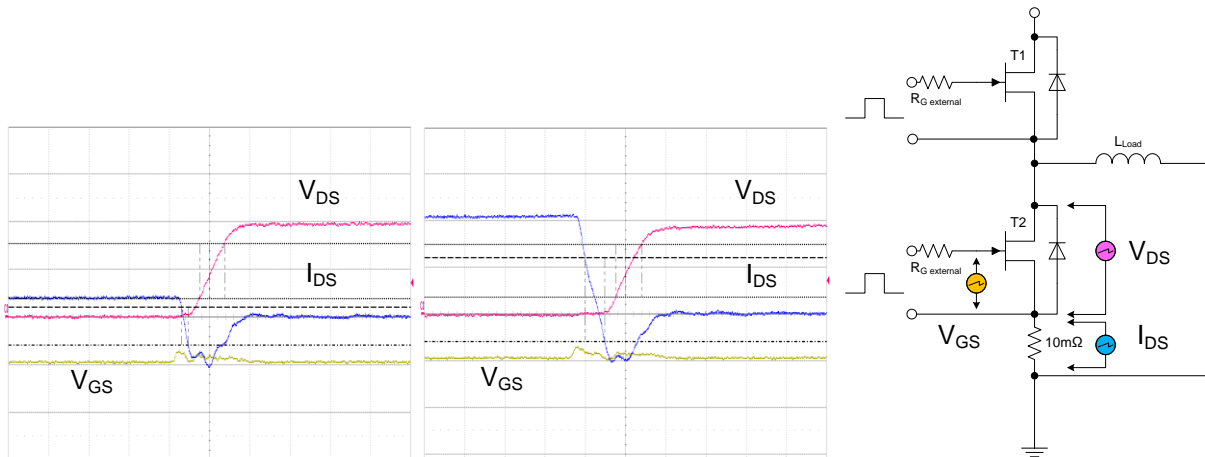

Figure 5:

reverse recovery characteristic  $I_{SD}= 2\text{ A}$  left and  $I_{SD}= 10\text{ A}$ ;  $T_f= 150\text{ }^\circ\text{C}$ ;  $V_{bulk}=400\text{ V}$ ;  $R_{G, external} = (T1) 3.3\ \Omega$  (T2)  $10\ \Omega$

Due to the material properties of SiC the forward voltage drop  $V_f$  of the internal body diode is significantly higher compared to a SiC schottky barrier diode. Therefore, active turn-on of the channel of the JFET during reverse operation (synchronous rectification) is the preferred way of operation.

### 1.3.4 Short circuit ruggedness

Due to excellent material properties and a very high temperature level for intrinsic carrier generation the device shows extremely good short circuit ruggedness.

### 1.3.5 Switching and conduction losses

The switching energies are typically one order of magnitude lower than the losses of IGBTs. It is noteworthy to consider that the JFET, as pure majority carrier device, has no forward knee voltage and can be used on its ohmic characteristic both in forward and reverse direction.

Nevertheless, the JFET shows a strong dependency of the switching energies as function of the used gate resistor. A low resistive value of the gate resistor is recommended to operate the JFET at optimal conditions. The conduction losses in comparison to Super Junction MOSFET's are less temperature dependent. A factor of only 1.6 between  $25\text{ }^\circ\text{C}$  and  $100\text{ }^\circ\text{C}$  is measurable.

## 1.4 Environmental Conditions

The parts are proofed according to IEC 60721-3-4 (4K4H). (Low air temperature  $-20\text{ }^\circ\text{C}$ ; High air temperature  $+55\text{ }^\circ\text{C}$ ; Low relative humidity 4 %; High relative humidity 100 %; Low absolute humidity  $0.9\text{ g/m}^3$ ; High absolute humidity  $36\text{ g/m}^3$ ...)

## 2 Maximum ratings

**Table 3 Maximum ratings**

Parameter	Symbol	Values			Unit	Note/Test Condition
		Min.	Typ.	Max.		
Continuous current, drain source <sup>1)</sup>	$I_{DS}$	-	-	26	A	$V_{GS} = 0 \text{ V}; T_C = 25 \text{ }^\circ\text{C};$ $R_{thJC} = R_{thJC, max}$
		-	-	18 <sup>5)</sup>		$V_{GS} = 0 \text{ V}; T_C = 100 \text{ }^\circ\text{C};$ $R_{thJC} = R_{thJC, max}$
		-	-	10 <sup>5)</sup>		$V_{GS} = 0 \text{ V}; T_C = 150 \text{ }^\circ\text{C};$ $R_{thJC} = R_{thJC, max}$
Pulsed current, drain source <sup>1)</sup>	$I_{DS, pulse}$	-	-	78		$V_{GS} = 0 \text{ V}; T_C = 25 \text{ }^\circ\text{C};$ $R_{thJC} = R_{thJC, max}$
		-	-	68 <sup>5)</sup>		$V_{GS} = 0 \text{ V}; T_C = 100 \text{ }^\circ\text{C};$ $R_{thJC} = R_{thJC, max}$
		-	-	60 <sup>5)</sup>		$V_{GS} = 0 \text{ V}; T_C = 150 \text{ }^\circ\text{C};$ $R_{thJC} = R_{thJC, max}$
Gate source voltage <sup>2)</sup>	$V_{GS}$	-19.5	-	2	V	
Power dissipation	$P_{tot}$	-	-	190	W	$T_C = 25 \text{ }^\circ\text{C}$
dV/ dt ruggedness, drain source	$dV_{DS}/ dt$	-	-	80	V/ ns	$I_{DS} \leq I_{DS, pulse}$
Pulsed current, source drain <sup>1)</sup>	$I_{SD, pulsed}$	-	-	78	A	$V_{GS} = -19.5 \text{ V}; T_j = 25 \text{ }^\circ\text{C};$ $R_{thJC} = R_{thJC, max}$
		-	-	60 <sup>5)</sup>		$V_{GS} = -19.5 \text{ V}; T_j = 150 \text{ }^\circ\text{C};$ $R_{thJC} = R_{thJC, max}$
dV/ dt ruggedness, source drain	$dV_{SD}/ dt$	-	-	80	V/ ns	$I_{SD} \leq I_{DS, pulse}$
Gate loop resistance, turn off <sup>3)</sup>	$R_{G, off}$	-	-	5.1	$\Omega$	
Operating and storage temp. <sup>4)</sup>	$T_j; T_{stg}$	-55	-	175	$^\circ\text{C}$	
Mounting torque		-	-	60	Ncm	M 2.5 screws

1) Limited by  $T_{j, max}$

2) The device is proofed against  $V_{GS}$  peaks. That allows to drive the parts shortly outside of the given maximum ratings ( $V_{GS, max} = 20 \text{ V}$ ,  $V_{GS, min} = -50 \text{ V}$  @  $t_{p, max} = 20 \text{ ns}$ ). This will result in a temporary gate leakage peak only.

3) See application information

4) Prolonged storage at high temperatures reduces the lifetime of the product. Tested according to EIA/JESD22-A103D

5) Limits derived from product characterization, parameter not measured during production

### 3 Thermal characteristics

Table 4 Thermal characteristics TO-247-3

Parameter	Symbol	Values			Unit	Note/Test Condition
		Min.	Typ.	Max.		
Thermal resistance, junction-case	$R_{thJC}$	–	–	0.78	K/W	leaded
Thermal resistance, junction-ambient	$R_{thJA}$	–	–	62		
Soldering temperature, wavesoldering only allowed at leads	$T_{sold}$	–	–	260	°C	1.6 mm (0.063 in.) from case for 10 s

### 4 Electrical characteristics

Table 5 Static characteristics

Parameter	Symbol	Values			Unit	Note/Test Condition	
		Min.	Typ.	Max.			
Breakdown voltage, drain source	$V_{(BR)DSS}$	1200	–	–	V	$V_{GS} = -19.5 V; I_{DS} = 1 mA;$ $T_C = -50 °C$	
Gate threshold voltage <sup>2)</sup>	$V_{GS(th)}$	-13.1 <sup>bin1</sup>	–	-12.0 <sup>bin1</sup>		$I_{DS} = 10 \mu A; V_{DS} = 40 V;$ $T_J = 25 °C$	
		-14.1 <sup>bin2</sup>	–	-12.9 <sup>bin2</sup>			
		-15.0 <sup>bin3</sup>	–	-13.9 <sup>bin3</sup>			
		-13.5 <sup>bin1</sup>	–	-12.3 <sup>bin1</sup>			$I_{DS} = 10 \mu A; V_{DS} = 40 V;$ $T_J = 100 °C; ^{1)}$
		-14.5 <sup>bin2</sup>	–	-13.2 <sup>bin2</sup>			
		-15.4 <sup>bin3</sup>	–	-14.2 <sup>bin3</sup>			
		Drain- source leakage current	$I_{DSS}$	–			1.5
–	3			60 <sup>1)</sup>	$V_{DS} = 1200 V; V_{GS} = -19.5 V;$ $T_C = 100 °C$		
–	6			120 <sup>1)</sup>	$V_{DS} = 1200 V; V_{GS} = -19.5 V;$ $T_J = 150 °C$		
Gate- source leakage current	$I_{GSS}$	–	–	90	$\mu A$	$V_{DS} = 0 V; V_{GS} = -19.5 V;$ $T_C = 25 °C$	
		–	–	360 <sup>1)</sup>		$V_{DS} = 0 V; V_{GS} = -19.5 V;$ $T_C = 100 °C$	
		–	–	720 <sup>1)</sup>		$V_{DS} = 0 V; V_{GS} = -19.5 V;$ $T_C = 150 °C$	
Drain- source on- state resistance	$R_{DS(on)}$	–	0.080	0.100	$\Omega$	$V_{GS} = 0 V; I_D = 9 A;$ $T_C = 25 °C$	
		–	0.130	–		$V_{GS} = 0 V; I_D = 9 A;$ $T_C = 100 °C$	
		–	0.175	–		$V_{GS} = 0 V; I_D = 9 A;$ $T_C = 150 °C$	
Gate resistance	$R_G$	–	1.4	–		$f = 1 MHz, open drain;$ $T_C = 25 °C$	

1) Limits derived from product characterization, parameter not measured during production

2) For paralleling see application note



**Table 6 Dynamic characteristics**

Parameter	Symbol	Values			Unit	Note/Test Condition
		Min.	Typ.	Max.		
Input capacitance	$C_{iss}$	–	1550	–	pF	$V_{GS} = -19.5\text{ V}; V_{DS} = 0\text{ V}; f = 1\text{ MHz}$
		–	1200	–		$V_{GS} = -19.5\text{ V}; V_{DS} = 800\text{ V}; f = 1\text{ MHz}$
Output capacitance	$C_{oss}$	–	1070	–	pF	$V_{GS} = -19.5\text{ V}; V_{DS} = 0\text{ V}; f = 1\text{ MHz}$
		–	80	–		$V_{GS} = -19.5\text{ V}; V_{DS} = 800\text{ V}; f = 1\text{ MHz}$
Effective output capacitance, energy related <sup>1)</sup>	$C_{o(er)}$	–	89	–	pF	$V_{GS} = -19.5\text{ V}; V_{DS} = 0\text{ V}/800\text{ V}; T_C = 25\text{ °C}$
Effective output capacitance, time related <sup>2)</sup>	$C_{o(tr)}$	–	112	–		$V_{GS} = -19.5\text{ V}; V_{DS} = 0\text{ V}/800\text{ V}; T_C = 25\text{ °C}$
Turn- on delay time	$t_{d(on)}$	–	49	–	ns	$V_{DS} = 800\text{ V}; V_{GS} = -19.5\text{ V}/0\text{ V}; I_D = 20\text{ A}; T_C = 25\text{ °C}; R_{G, tot} = 2\text{ }\Omega$
Turn- off delay time	$t_{d(off)}$	–	30	–		
Rise time	$t_r$	–	26	–		
Fall time	$t_f$	–	19	–		

1)  $C_{o(er)}$  is a fixed capacitance that gives the same stored energy as  $C_{oss}$  while  $V_{DS}$  is rising from 0 V to 800 V

2)  $C_{o(tr)}$  is a fixed capacitance that gives the same charging time as  $C_{oss}$  while  $V_{DS}$  is rising from 0 V to 800 V

**Table 7 Gate charge characteristics**

Parameter	Symbol	Values			Unit	Note/Test Condition
		Min.	Typ.	Max.		
Gate charge, gate to source	$Q_{GS}$	–	16	–	nC	$V_{DS} = 800\text{ V to }0\text{ V}; I_D = 18\text{ A}; V_{GS} = -19.5\text{ V to }0\text{ V}$
Gate charge, gate to drain	$Q_{GD}$	–	32	–		
Gate charge, total	$Q_G$	–	72	–		
Gate plateau voltage	$V_{plateau}$	–	-8	–	V	

**Table 8 Reverse diode characteristics**

Parameter	Symbol	Values			Unit	Note/Test Condition
		Min.	Typ.	Max.		
Diode forward voltage	$V_{SD}$	–	7.2	–	V	$I_{SD} = 18\text{ A}; V_{GS} = -19.5\text{ V}; T_C = 25\text{ °C}$
		–	7.5	–		$I_{SD} = 18\text{ A}; V_{GS} = -19.5\text{ V}; T_C = 100\text{ °C}$
		–	7.6	–		$I_{SD} = 18\text{ A}; V_{GS} = -19.5\text{ V}; T_C = 150\text{ °C}$
Reverse recovery time	$t_{rr}$	–	15.6	–	ns	$I_{SD} = 18\text{ A}; V_{DS} = 800\text{ V}; R_G = 0\text{ }\Omega; T_j = 25\text{ °C}$
Reverse recovery charge	$Q_{rr}$	–	118	–		
Peak reverse recovery current	$I_{rrm}$	–	11	–		
Current slope forward	$dl_f/dt$	–	3	–		
Current slope reverse	$dl_r/dt$	–	1.3	–		

## 5 Electrical characteristics diagrams

Table 9

Typical output characteristic	Typical output characteristic
$I_{DS} = f(V_{DS}); T_J = 25\text{ °C}; \text{parameter: } V_{GS}; V_{pi\ 25\text{ °C}}$	$I_{DS} = f(V_{DS}); T_J = 100\text{ °C}; \text{parameter: } V_{GS}; V_{pi\ 25\text{ °C}}$

Table 10

Typical output characteristic	Typical drain- source on- state resistance
$I_{DS} = f(V_{DS}); T_J = 150\text{ °C}; \text{parameter: } V_{GS}; V_{pi\ 25\text{ °C}}$	$R_{DS(on)} = f(T_J); V_{GS} = 0\text{ V}; T_J = 25\text{ °C}; \text{parameter: } I_{DS}$

Table 11

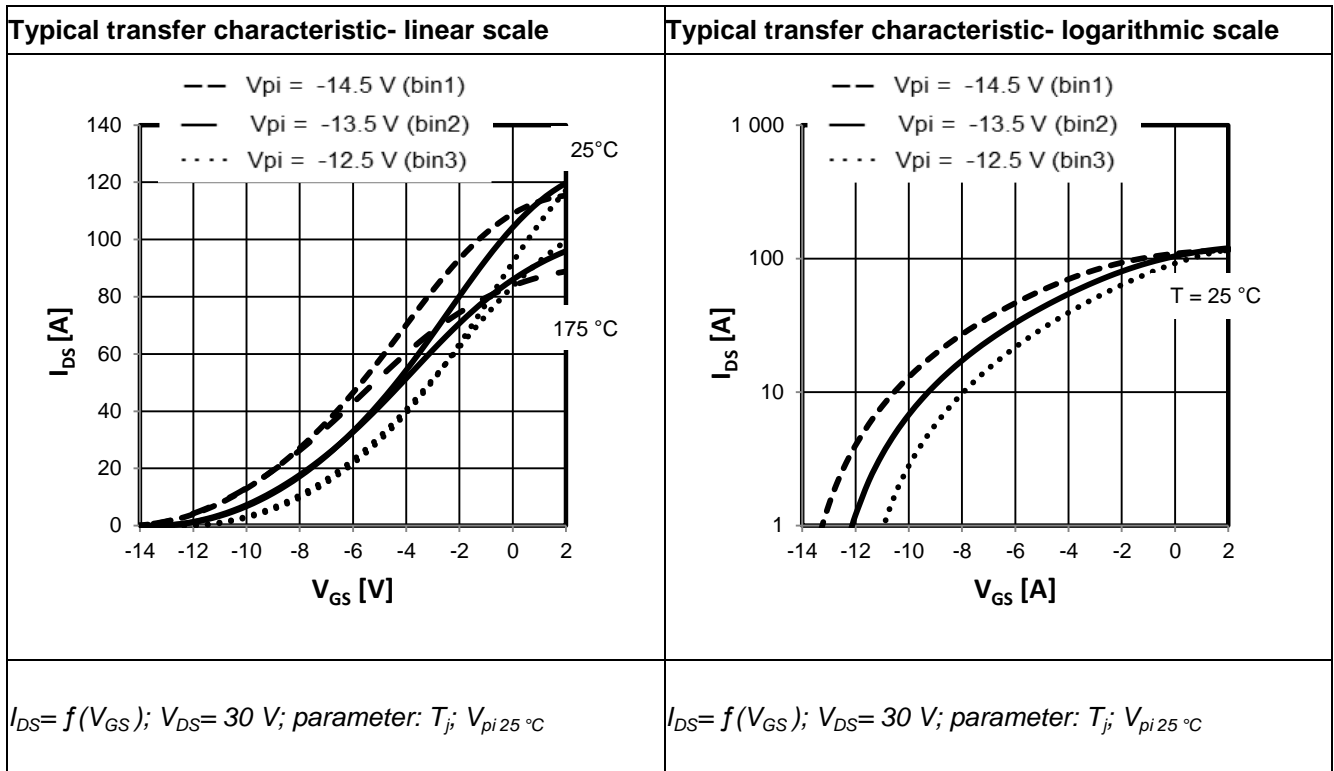

Table 12

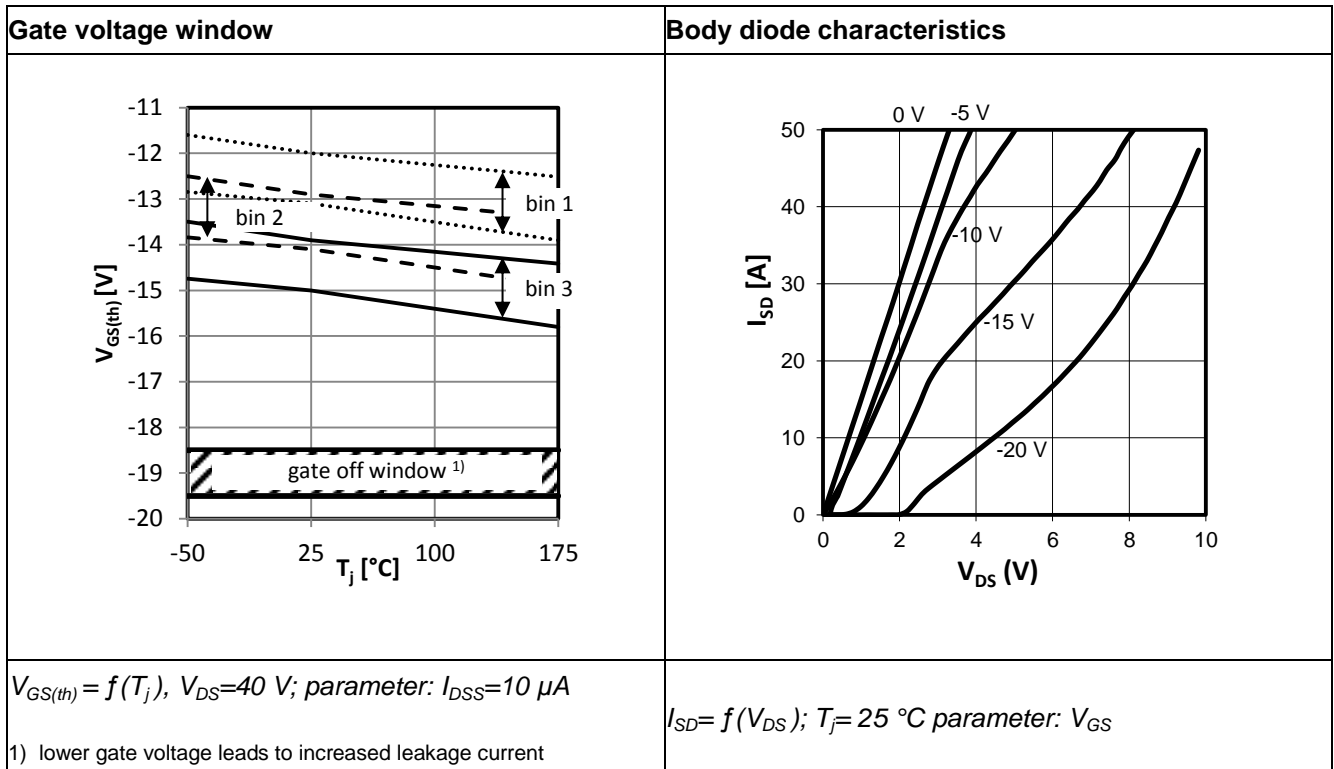

Table 13

Typical gate charge	Typical breakdown voltage
$V_{GS} = f(Q_G); V_{DS} = 800 \text{ V}; \text{parameter: } I_{DS}$	$V_{BR(dss)} = f(T_j); I_{DS} = 1 \text{ mA}$

Table 14

Typical capacitances	Typical stored energy in $C_{oss}$
$C_{iss} = f(V_{DS}); V_{GS} = -19.5 \text{ V}; f = 1 \text{ MHz}$ $C_{oss} = f(V_{DS}); V_{GS} = -19.5 \text{ V}; f = 1 \text{ MHz}$ $C_{rss} = f(V_{DS}); V_{GS} = -19.5 \text{ V}; f = 1 \text{ MHz}$	$E_{oss} = f(V_{DS})$

Table 15

Typical stored charge in $C_{oss}$	Maximum gate leakage current $I_{GSS}$
$Q_{oss} = f(V_{DS})$	$I_{GSS} = f(T_j)$ ; parameter $V_{GS} = -19.5 V$

Table 16

Typical switching losses- JFET vs. IDH15S120	Typical switching losses- JFET vs. JFET
$E_{off} = f(R_G)$ ; $V_{bulk} = 800 V$ ; $T_j = 25 °C$ ; $V_{pi} = -13.5 V$ ; parameter: $I_{DS}$	$E_{off} = f(R_G)$ ; $V_{bulk} = 800 V$ ; $T_j = 25 °C$ ; $V_{pi} = -13.5 V$ ; parameter: $I_{DS}$

Table 17

Typical switching losses- JFET vs. IDH15S120 <sup>1)</sup>	Typical switching losses- JFET vs. JFET <sup>1)</sup>
<p><math>E_{on} = f(I_{DS}); V_{bulk} = 800 \text{ V}; T_j = 25 \text{ }^\circ\text{C}; R_{G\ on} = 3.3 \text{ } \Omega;</math>  <math>V_{pi} = -13.5 \text{ V};</math> parameter: <math>V_{bulk}</math></p>	<p><math>E_{on} = f(I_{DS}); V_{bulk} = 800 \text{ V}; T_j = 25 \text{ }^\circ\text{C}; R_{G\ on} = 3.3 \text{ } \Omega;</math>  <math>V_{pi} = -13.5 \text{ V};</math> parameter: <math>V_{bulk}</math></p>

Table 18

Typical switching losses- JFET vs. IDH15S120 <sup>1)</sup>	Typical switching losses- JFET vs. JFET <sup>1)</sup>
<p><math>E_{off} = f(I_{DS}); V_{bulk} = 800 \text{ V}; T_j = 25 \text{ }^\circ\text{C}; R_{G\ off} = 3.3 \text{ } \Omega;</math>  <math>V_{pi} = -13.5 \text{ V};</math> parameter: <math>V_{bulk}</math></p>	<p><math>E_{off} = f(I_{DS}); V_{bulk} = 800 \text{ V}; T_j = 25 \text{ }^\circ\text{C}; R_{G\ off} = 3.3 \text{ } \Omega;</math>  <math>V_{pi} = -13.5 \text{ V};</math> parameter: <math>V_{bulk}</math></p>

1) Measured with Push Pull stage close to the gate;  $R_g = 0 \text{ } \Omega$

Table 19

Power dissipation	Safe operating area
$P_{tot} = f(T_c)$	$I_{DS} = f(V_{DS}); T_c = 25\text{ °C}; D = 0$ parameter: $t_p$

Table 20

Safe operating area	Safe operating area
$I_{DS} = f(V_{DS}); T_c = 100\text{ °C}; D = 0$ parameter: $t_p$	$I_{DS} = f(V_{DS}); T_c = 150\text{ °C}; D = 0$ parameter: $t_p$

Table 21

Safe operating area diode	Maximum transient thermal impedance
$I_{SD\ max} = f(D = t_p / T); T_c = 25\ ^\circ\text{C}; \text{parameter: } t_p$	$Z_{THjc} = f(t_p); \text{parameter: } D = t_p / T$



## 6 Test circuits

Table 22

Switching times test circuit for inductive load	Switching time waveform

Table 23

Unclamped inductive load test circuit	Unclamped inductive waveform

Table 24

Test circuit for diode characteristics	Diode recovery waveform

## 7 Package outlines

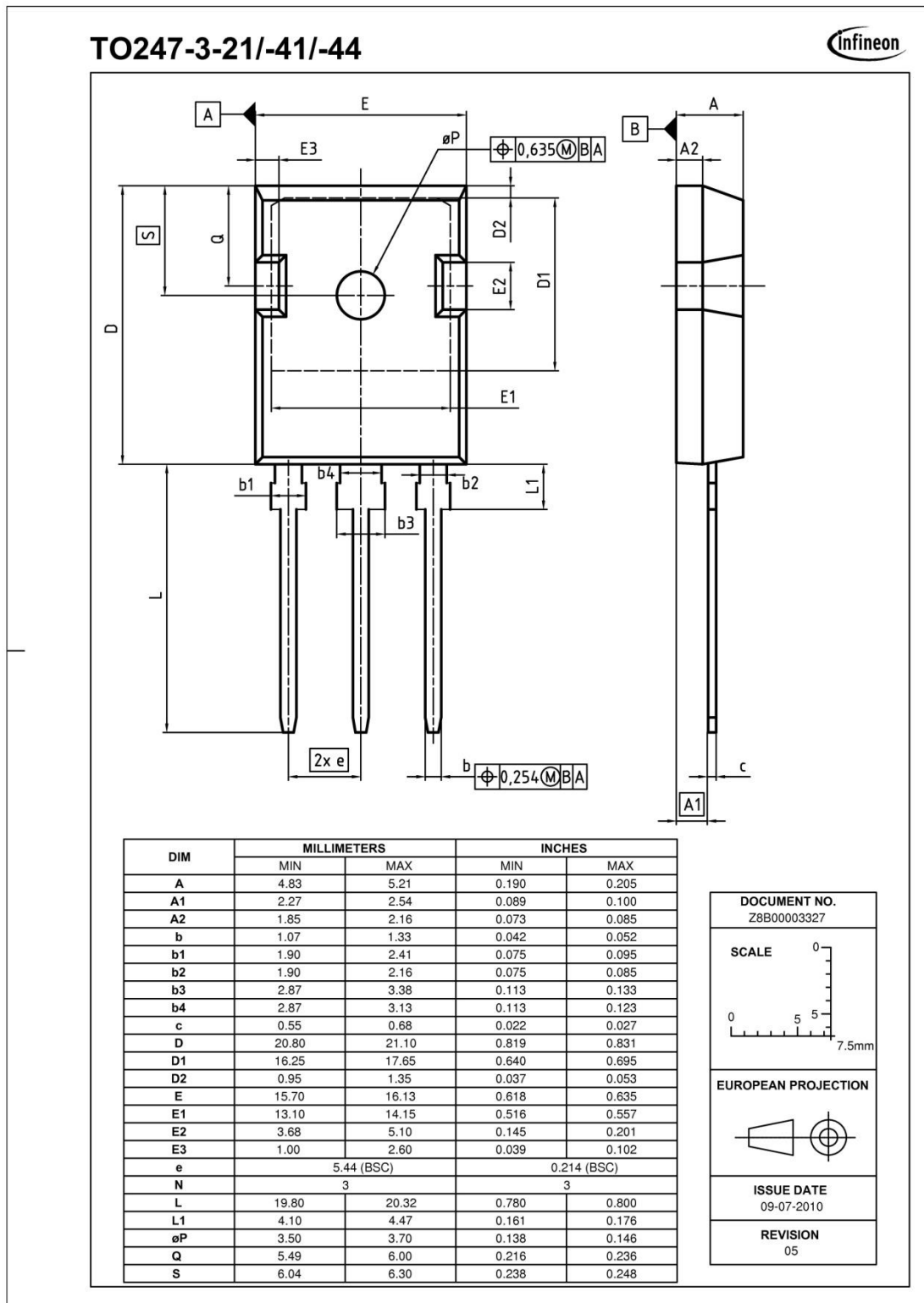

Figure 1 Outlines PG-TO247-3, dimensions in mm/inches

## 8 Revision History

---

### IJW120R100T1, 1200 V CoolSiC™ Power Transistor

Revision History: Rev. 2.0, <2013-09-11>

Previous Revision:

Revision	Subjects (major changes since last version)
0.9	Target datasheet
1.0	Preliminary Datasheet
2.0	Final Datasheet

#### We Listen to Your Comments

Any information within this document that you feel is wrong, unclear or missing at all? Your feedback will help us to continuously improve the quality of this document.

Please send your proposal (including a reference to this document) to: [erratum@infineon.com](mailto:erratum@infineon.com)

Edition 2011-12-09

Published by

Infineon Technologies AG

81726 Munich, Germany

© 2011 Infineon Technologies AG

All Rights Reserved.



#### Legal Disclaimer

The information given in this document shall in no event be regarded as a guarantee of conditions or characteristics. With respect to any examples or hints given herein, any typical values stated herein and/or any information regarding the application of the device, Infineon Technologies hereby disclaims any and all warranties and liabilities of any kind, including without limitation, warranties of non-infringement of intellectual property rights of any third party.

#### Information

For further information on technology, delivery terms and conditions and prices, please contact the nearest Infineon Technologies Office ([www.infineon.com](http://www.infineon.com)).

#### Warnings

Due to technical requirements, components may contain dangerous substances. For information on the types in question, please contact the nearest Infineon Technologies Office.

The Infineon Technologies component described in this Data Sheet may be used in life-support devices or systems and/or automotive, aviation and aerospace applications or systems only with the express written approval of Infineon Technologies, if a failure of such components can reasonably be expected to cause the failure of that life-support, automotive, aviation and aerospace device or system or to affect the safety or effectiveness of that device or system. Life support devices or systems are intended to be implanted in the human body or to support and/or maintain and sustain and/or protect human life. If they fail, it is reasonable to assume that the health of the user or other persons may be endangered.

[www.infineon.com](http://www.infineon.com)

Published by Infineon Technologies AG

# Mouser Electronics

Authorized Distributor

Click to View Pricing, Inventory, Delivery & Lifecycle Information:

[Infineon:](#)

[IJW120R100T1](#)