

# TLE9185QXW

## BLDC Driver



RoHS



ISO26262  
ready

## 1 Overview

### Features

- Low-drop voltage regulator 5 V, 250 mA for main supply
- Three half-bridge gate drivers for external N-channel MOSFETs
- Adaptive MOSFET gate control:
  - Regulation of the MOSFET switching time
  - Reduced switching losses in PWM mode
  - High efficient constant gate charge
- Control of reverse battery protection MOSFET
- One low-side capable current sense amplifier (CSA) with configurable gain for protection and diagnosis
- Configurable wake-up sources
- Six PWM inputs
  - High-side and low-side PWM capable
  - Active free-wheeling
  - Up to 25 kHz PWM frequency
- 32 bit serial peripheral interface (SPI) with cyclic redundancy check (CRC)
- Very low quiescent current consumption in Stop Mode and Sleep Mode
- Periodic cyclic wake in Normal Mode, Stop Mode and Sleep Mode
- Reset and interrupt output
- Drain-source monitoring and open-load detection
- Configurable time-out and window watchdog
- Overtemperature and short circuit protection features
- Leadless power package with support of optical lead tip inspection
- Extended operating range (Grade 0)
- Green Product (RoHS compliant)

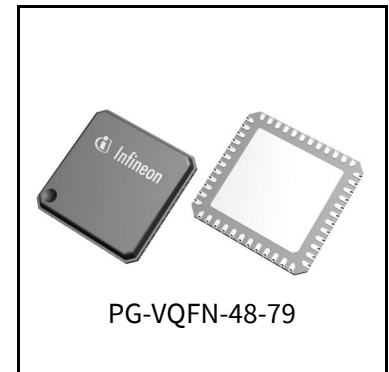

## Overview

## Potential applications

- Auxiliary pumps (fuel, water, etc.)
- Blower motor
- Engine cooling fan
- Sunroof module
- Transfer case

## Product validation

Qualified for automotive applications. Product validation according to AEC-Q100.

## Description

The TLE9185QXW is a multifunctional IC with integrated power supply, multiple half-bridges and support features in an exposed pad PG-VQFN-48 power package. The device is designed for various motor control automotive applications.

To support these applications, the BLDC Driver provides the main functions, such as a 5 V low-dropout voltage regulator, three half-bridges for BDLC motor control, one current sense amplifier and one 32 bit serial peripheral interface (SPI).

The device includes diagnostic and supervision features, such as drain-source monitoring and open-load detection, short circuit protection, configurable time-out and window watchdog, as well as overtemperature protection.

The device is intended to operate with 5.0 V microcontroller.

Type	Package	Marking
TLE9185QXW	PG-VQFN-48-79	TLE9185 QXW

## Table of Contents

<b>1</b>	<b>Overview</b> .....	<b>1</b>
<b>2</b>	<b>Block Diagram</b> .....	<b>7</b>
<b>3</b>	<b>Pin Configuration</b> .....	<b>8</b>
3.1	Pin Assignment .....	8
3.2	Pin Definitions and Functions .....	8
3.3	Hints for not functional pins .....	10
<b>4</b>	<b>General Product Characteristics</b> .....	<b>11</b>
4.1	Absolute Maximum Ratings .....	11
4.2	Functional Range .....	12
4.3	Thermal Resistance .....	13
4.4	Current Consumption .....	13
<b>5</b>	<b>System Features</b> .....	<b>16</b>
5.1	Short State Machine Description .....	16
5.2	Device Configuration .....	17
5.3	Block Description of State Machine .....	19
5.4	State Machine Modes Description .....	20
5.4.1	Init Mode .....	20
5.4.2	Normal Mode .....	20
5.4.3	Stop Mode .....	21
5.4.4	Sleep Mode .....	22
5.4.5	Restart Mode .....	22
5.4.6	Fail-Safe Mode .....	23
5.4.7	Software Development Mode .....	24
5.5	Transition Between States .....	24
5.5.1	Transition into Init Mode .....	24
5.5.2	Init Mode -> Normal Mode .....	25
5.5.3	Normal Mode -> Stop Mode .....	25
5.5.4	Normal Mode -> Sleep Mode .....	26
5.5.5	Stop Mode -> Normal Mode .....	26
5.5.6	Sleep Mode -> Restart Mode .....	27
5.5.7	Restart Mode -> Normal Mode .....	27
5.5.8	Fail-Safe Mode -> Restart Mode .....	27
5.6	Reaction on Detected Faults .....	28
5.6.1	Stay in Current State .....	28
5.6.2	Transition into Restart Mode .....	28
5.6.3	Transition into Fail-Safe Mode .....	29
5.7	Wake Features .....	29
5.7.1	Cyclic Wake .....	29
5.7.2	Internal Timers .....	30
5.8	VS Supply Multiplexing .....	31
<b>6</b>	<b>Voltage Regulator 1</b> .....	<b>32</b>
6.1	Block Description .....	32
6.2	Functional Description .....	33
6.3	Electrical Characteristics .....	34

<b>7</b>	<b>High-Voltage Wake Input</b>	<b>36</b>
7.1	Block Description	36
7.2	High-Voltage Wake Function	37
7.2.1	Functional Description	37
7.2.2	Wake Input Configuration	37
7.3	Electrical Characteristics	39
<b>8</b>	<b>Interrupt Function</b>	<b>40</b>
8.1	Block and Functional Description	40
8.2	Electrical Characteristics	43
<b>9</b>	<b>Gate Drivers</b>	<b>44</b>
9.1	MOSFET control	44
9.2	Static activation	45
9.2.1	Static activation of a high-side MOSFET	46
9.2.2	Static activation of a low-side MOSFET	49
9.2.3	Turn-off of the high-side and low-side MOSFETs of a half-bridge	49
9.3	PWM operation	50
9.3.1	Determination of the active and freewheeling MOSFET	50
9.3.2	Configurations in PWM mode	50
9.3.3	PWM operation with 3 PWM inputs	53
9.3.3.1	Control signals with active free-wheeling (AFW <sub>x</sub> = 1)	54
9.3.3.2	Control signals with passive free-wheeling (AFW <sub>x</sub> = 0)	59
9.3.3.3	Time modulation of pre-charge and pre-discharge times	63
9.3.3.4	Operation at high and low duty cycles	66
9.3.3.5	Measurements of the switching times	66
9.3.4	PWM operation with 6 PWM inputs	67
9.3.5	Status bits for regulation of turn-on and turn-off delay times	72
9.3.6	Gate driver current	74
9.4	Passive discharge	79
9.5	Slam mode	80
9.6	Parking braking mode	80
9.7	Charge pump	81
9.8	Frequency modulation	82
9.9	Electrical characteristics gate driver	83
<b>10</b>	<b>Supervision Functions</b>	<b>91</b>
10.1	Reset Function	91
10.1.1	Reset Output Description	91
10.1.2	Soft Reset Description	92
10.2	Watchdog Function	93
10.2.1	Time-Out Watchdog	94
10.2.2	Window Watchdog	95
10.2.3	Watchdog Setting Check Sum	95
10.2.4	Watchdog during Stop Mode	96
10.3	VSINT Power On Reset	97
10.4	VSINT Under- and Overvoltage	98
10.4.1	VSINT Undervoltage	98
10.4.2	VSINT Overvoltage	98

10.5	VS Under- and Overvoltage .....	99
10.5.1	VS Undervoltage .....	99
10.5.2	VS Overvoltage .....	99
10.6	VCC1 Over-/ Undervoltage and Undervoltage Prewarning .....	100
10.6.1	VCC1 Undervoltage and Undervoltage Prewarning .....	100
10.6.2	VCC1 Overvoltage .....	101
10.7	VCC1 Short Circuit Diagnostics .....	101
10.8	Thermal Protection .....	102
10.8.1	Individual Thermal Shutdown .....	102
10.8.2	Temperature Prewarning .....	102
10.8.3	Thermal Shutdown .....	102
10.9	Bridge driver .....	103
10.9.1	Bridge driver supervision with activated charge pump .....	103
10.9.1.1	Drain-source voltage monitoring .....	103
10.9.1.2	Cross-current protection and drain-source overvoltage blank time .....	104
10.9.1.3	OFF-state diagnostic .....	105
10.9.1.4	Charge pump undervoltage .....	106
10.9.1.5	Switching parameters of MOSFETs in PWM mode .....	106
10.9.2	Low-side drain-source voltage monitoring during braking .....	106
10.9.3	VS or VSINT Overvoltage braking .....	107
10.10	Current sense amplifier .....	107
10.10.1	Unidirectional and bidirectional operation .....	107
10.10.2	Gain configuration .....	108
10.10.3	Overcurrent Detection .....	108
10.10.4	CSO output capacitor .....	110
10.11	Electrical Characteristics .....	111
<b>11</b>	<b>Serial Peripheral Interface .....</b>	<b>119</b>
11.1	SPI Block Description .....	119
11.2	Failure Signalization in the SPI Data Output .....	120
11.3	SPI Programming .....	122
11.3.1	CRC .....	123
11.4	SPI Bit Mapping .....	125
11.4.1	Register Banking .....	126
11.5	SPI control registers .....	128
11.5.1	Device Control Registers .....	130
11.5.2	Control registers bridge driver .....	142
11.6	SPI status information registers .....	163
11.6.1	Device Status Registers .....	164
11.6.2	Status registers bridge driver .....	171
11.6.3	Family and product information register .....	183
11.7	Electrical Characteristics .....	184
<b>12</b>	<b>Application Information .....</b>	<b>186</b>
12.1	Application Diagrams .....	186
12.2	ESD Tests .....	189
12.2.1	ESD according to IEC61000-4-2 .....	189
12.3	Thermal Behavior of Package .....	190
12.4	Further Application Information .....	190

<b>13</b>	<b>Package Outlines .....</b>	<b>191</b>
<b>14</b>	<b>Revision History .....</b>	<b>192</b>

Block Diagram

2 Block Diagram

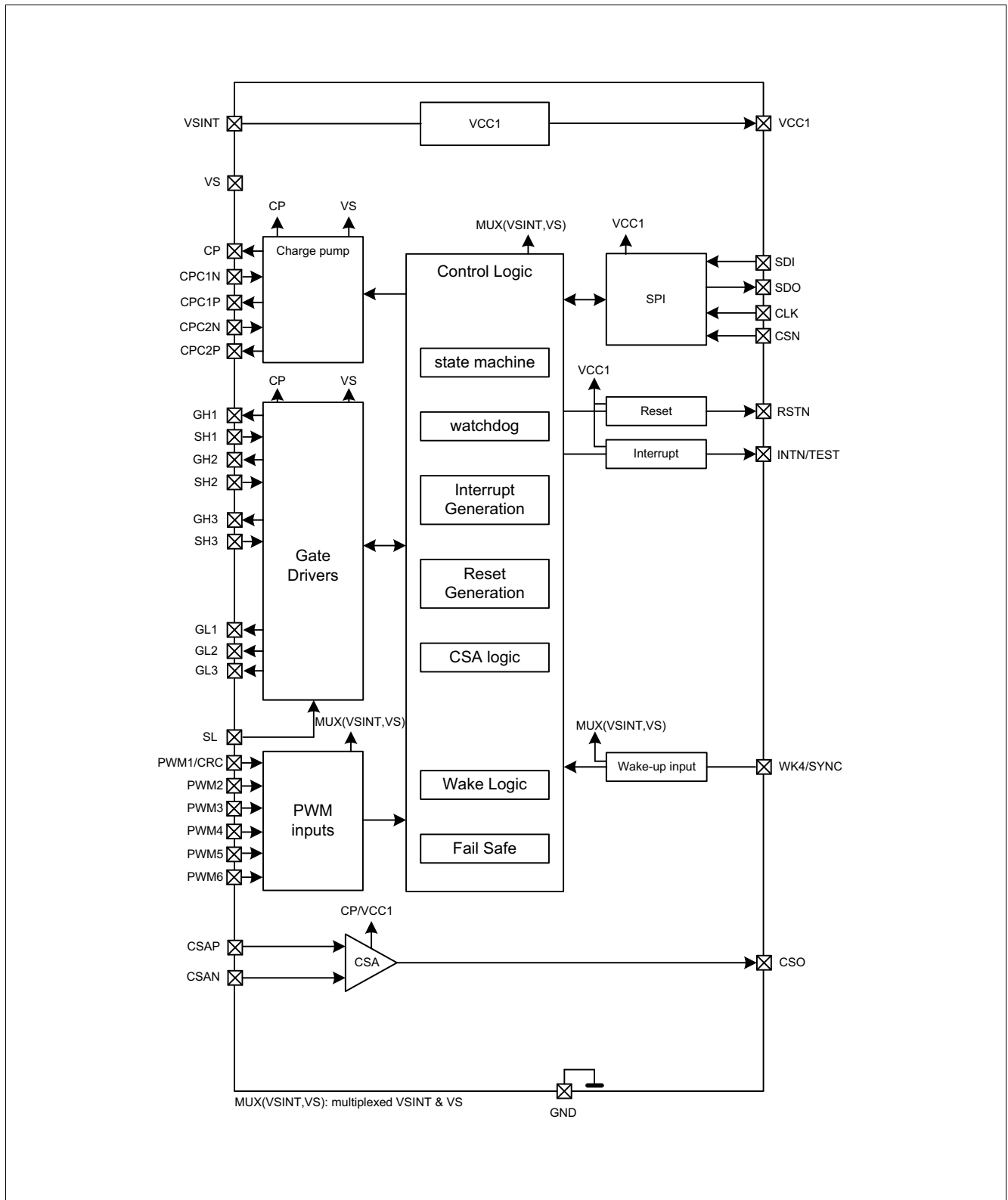

Figure 1 Block Diagram

Pin Configuration

### 3 Pin Configuration

#### 3.1 Pin Assignment

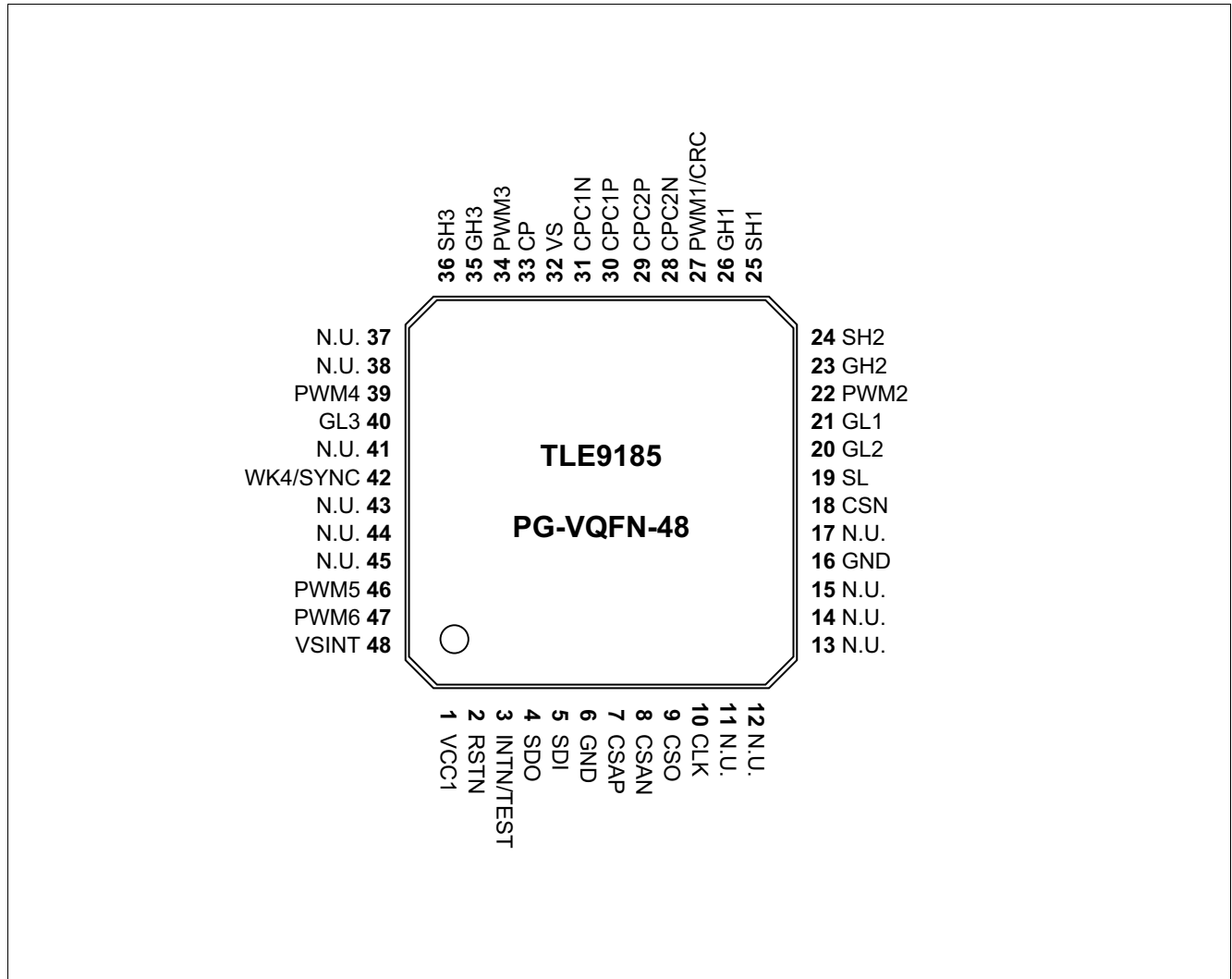

Figure 2 Pin Configuration

#### 3.2 Pin Definitions and Functions

Pin	Symbol	Function
1	VCC1	<b>Voltage reference for CSA, SPI and PWM inputs.</b> Output voltage 1
2	RSTN	<b>Reset Output.</b> Active LOW, internally passive pull-up with open-drain output
3	INTN/TEST	<b>Interrupt Output.</b> Active LOW output, push-pull structure <b>TEST.</b> Connect to GND (via pull-down) to activate Software Development Mode
4	SDO	<b>SPI Data Output to Microcontroller (=MISO).</b> Push-pull structure
5	SDI	<b>SPI Data Input from Microcontroller (=MOSI).</b> Internal pull-down
6	GND	<b>Ground.</b> Analog/digital ground
7	CSAP	<b>Not Inverting input of Current Sense Amplifier.</b>



**Pin Configuration**

<b>Pin</b>	<b>Symbol</b>	<b>Function</b>
8	CSAN	<b>Inverting input of Current Sense Amplifier.</b>
9	CSO	<b>Current Sense Amplifier Output.</b>
10	CLK	<b>SPI Clock Input.</b> Internal passive pull-down
11	N.U.	<b>Not used.</b>
12	N.U.	<b>Not used.</b>
13	N.U.	<b>Not used.</b>
14	N.U.	<b>Not used.</b>
15	N.U.	<b>Not used.</b>
16	GND	<b>Ground</b>
17	N.U.	<b>Not used.</b>
18	CSN	<b>SPI Chip Select Not input.</b> Internal passive pull-up
19	SL	<b>Source Low Side.</b>
20	GL2	<b>Gate Low Side 2.</b>
21	GL1	<b>Gate Low Side 1.</b>
22	PWM2	<b>PWM input 2.</b> Internal passive pull-up
23	GH2	<b>Gate High Side 2.</b>
24	SH2	<b>Source High Side 2.</b>
25	SH1	<b>Source High Side 1.</b>
26	GH1	<b>Gate High Side 1.</b>
27	PWM1/CRC	<b>PWM input 1.</b> Internal passive pull-down <b>CRC.</b> Connect to GND (via pull-down) to activate CRC functionality
28	CPC2N	<b>Negative connection to Charge Pump Capacitor 2.</b>
29	CPC2P	<b>Positive connection to Charge Pump Capacitor 2.</b>
30	CPC1P	<b>Positive connection to Charge Pump Capacitor 1.</b>
31	CPC1N	<b>Negative connection to Charge Pump Capacitor 1.</b>
32	VS	<b>Supply voltage for Bridge Drivers and Charge pump.</b> Connected to the battery voltage after reverse protection.
33	CP	<b>Charge Pump output voltage.</b>
34	PWM3	<b>PWM input 3.</b> Internal passive pull-down
35	GH3	<b>Gate High Side 3.</b>
36	SH3	<b>Source High Side 3.</b>
37	N.U.	<b>Not used.</b>
38	N.U.	<b>Not used.</b>
39	PWM4	<b>PWM input 4.</b> Internal passive pull-down
40	GL3	<b>Gate Low Side 3.</b>
41	N.U.	<b>Not used.</b>
42	WK4/SYNC	<b>Wake-up input 4/Sync.</b>
43	N.U.	<b>Not used.</b>
44	N.U.	<b>Not used.</b>

## Pin Configuration

Pin	Symbol	Function
45	N.U.	<b>Not used.</b>
46	PWM5	<b>PWM input 5.</b> Internal passive pull-down
47	PWM6	<b>PWM input 6.</b> Internal passive pull-down
48	VSINT	<b>Voltage regulator and main supply voltage.</b> Connected to the battery voltage after reverse protection
Cooling Tab	GND	Cooling Tab - Exposed Die Pad; For cooling purposes only, do not use as an electrical ground <sup>1)</sup>

1) The exposed die pad at the bottom of the package allows better power dissipation of heat from the device via the PCB. The exposed die pad is not connected to any active part of the IC. However, it should be connected to GND for the best EMC performance.

*Note: The GND pin as well as the Cooling Tab must be connected to one common GND potential.*

### 3.3 Hints for not functional pins

It must be ensured that the correct configurations are also selected, i.e. in case functions are not used that they are disabled via SPI. Unused pins should be handled as follows:

- **N.U.:** not used; internally bonded for testing purpose; leave open except pin 17. Pin 17 to be connected to VS.
- **RSVD:** must be connected to GND.

**General Product Characteristics**

**4 General Product Characteristics**

**4.1 Absolute Maximum Ratings**

**Table 1 Absolute Maximum Ratings<sup>1)</sup>**

$T_j = -40^\circ\text{C}$  to  $+175^\circ\text{C}$ ; all voltages with respect to ground, positive current flowing into pin (unless otherwise specified)

Parameter	Symbol	Values			Unit	Note or Test Condition	Number
		Min.	Typ.	Max.			
<b>Voltages</b>							
Supply Voltage VS	$V_{S, \max}$	-0.3	-	28	V	-	P_4.1.1
Supply Voltage VS	$V_{S, \max}$	-0.3	-	40	V	Load Dump	P_4.1.2
Supply Voltage VSINT	$V_{SINT, \max}$	-0.3	-	28	V	-	P_4.1.3
Supply Voltage VSINT	$V_{SINT, \max}$	-0.3	-	40	V	Load Dump	P_4.1.4
Voltage Regulator 1	$V_{CC1, \max}$	-0.3	-	5.5	V		P_4.1.7
Charge Pump Output Pin (CP)	$V_{CP, \max}$	$V_S - 0.8$	-	$V_S + 17$	V	$I_{CP} > -200 \mu\text{A}$ if CP is disabled	P_4.1.8
CPC1P, CPC2P	$V_{CPCxP, \max}$	-0.3	-	$V_S + 17$	V		P_4.1.38
CPC1N, CPC2N	$V_{CPCxN, \max}$	-0.3	-	$V_S + 0.3$	V		P_4.1.39
Bridge Driver Gate High Side (GHx)	$V_{GHx, \max}$	-8.0	-	40	V	-	P_4.1.11
Bridge Driver Gate Low Side (GLx)	$V_{GLx, \max}$	-8.0	-	24	V	-	P_4.1.12
Voltage difference between GHx-SHx and between GLx-SLx	$V_{GS}$	-0.3	-	16	V	-	P_4.1.13
Bridge Driver Source High (SHx)	$V_{SHx, \max}$	-8.0	-	40	V	-	P_4.1.14
Bridge Driver Source Low Side SL	$V_{SL, \max}$	-8.0	-	6.0	V	-	P_4.1.15
Current Sense Amplifier inputs (CSAP, CSAN)	$V_{CSx, \max}$	-8.0	-	+8.0	V	-	P_4.1.16
Current Sense Amplifier Output CSO	$V_{CSx, \max}$	-0.3	-	$V_{CC1} + 0.3$	V	-	P_4.1.17
Differential input voltage range CSAPx - CSANx	$V_{CSA, \text{Diff}}$	-8.0	-	8.0	V	-	P_4.1.18
Wake Input WKx	$V_{WKx, \max}$	-0.3	-	40	V	-	P_4.1.19
PWM1/CRC, PWM2, PWM3, PWM4, PWM 5, PWM6 Input Pins	$V_{PWM1-2-3-4-5-6, \max}$	-0.3	-	40	V	-	P_4.1.25
Logic Input Pins (SDI, CLK, )	$V_{I, \max}$	-0.3	-	$V_{CC1} + 0.3$	V	-	P_4.1.28

**General Product Characteristics**

**Table 1 Absolute Maximum Ratings<sup>1)</sup>** (cont'd)

$T_j = -40^\circ\text{C}$  to  $+175^\circ\text{C}$ ; all voltages with respect to ground, positive current flowing into pin (unless otherwise specified)

Parameter	Symbol	Values			Unit	Note or Test Condition	Number
		Min.	Typ.	Max.			
CSN	$V_{CSN}$	-0.3	–	40	V	–	P_4.1.29
Logic Output Pins (SDO, RSTN, INTN, )	$V_{O,max}$	-0.3	–	$V_{CC1} + 0.3$	V	–	P_4.1.30

**Temperatures**

Junction Temperature	$T_j$	-40	–	175	$^\circ\text{C}$	–	P_4.1.40
Storage Temperature	$T_{stg}$	-55	–	150	$^\circ\text{C}$	–	P_4.1.33

**ESD Susceptibility**

ESD Resistivity	$V_{ESD,11}$	-2	–	2	kV	HBM <sup>2)</sup>	P_4.1.34
ESD Resistivity to GND	$V_{ESD,12}$	-8	–	8	kV	HBM <sup>2)3)</sup>	P_4.1.35
ESD Resistivity to GND	$V_{ESD,21}$	-500	–	500	V	CDM <sup>4)</sup>	P_4.1.36
ESD Resistivity Pin 1, 12,13,24,25,36,37,48 (corner pins) to GND	$V_{ESD,22}$	-750	–	750	V	CDM <sup>4)</sup>	P_4.1.37

- 1) Not subject to production test, specified by design.
- 2) ESD susceptibility, HBM according to ANSI/ESDA/JEDEC JS-001 (1.5 kV, 100 pF).
- 3) For ESD “GUN” Resistivity (according to IEC61000-4-2 “gun test” (150 pF, 330  $\Omega$ )), is shown in Application Information and test report will be provided from IBEE.
- 4) ESD susceptibility, Charged Device Model “CDM” EIA/JESD22-C101 or ESDA STM5.3.1.

**Notes**

1. Stresses above the ones listed here may cause permanent damage to the device. Exposure to absolute maximum rating conditions for extended periods may affect device reliability.
2. Integrated protection functions are designed to prevent IC destruction under fault conditions described in the data sheet. Fault conditions are considered as “outside” normal operating range. Protection functions are not designed for continuous repetitive operation.

**4.2 Functional Range**

**Table 2 Functional Range<sup>1)</sup>**

Parameter	Symbol	Values			Unit	Note or Test Condition	Number
		Min.	Typ.	Max.			
Supply Voltage	$V_{SINT,func}$	$V_{POR,f}$	–	28	V	2)	P_4.2.1
Bridge Supply Voltage	$V_{S,func}$	6.0	–	28	V	–	P_4.2.2
Junction Temperature	$T_j$	-40	–	175	$^\circ\text{C}$	–	P_4.2.8

- 1) Not subject to production test, specified by design.
- 2) Including Power-On Reset, Over- and Undervoltage Protection.

*Note:* Within the functional range the IC operates as described in the circuit description. The electrical characteristics are specified within the conditions given in the related electrical characteristics table.

**General Product Characteristics**

**Device Behavior Outside of Specified Functional Range**

- $28\text{ V} < V_{SINT,func} < 40\text{ V}$ : Device will still be functional including the state machine; the specified electrical characteristics might not be ensured anymore. The  $V_{CC1}$  is working properly, however, a thermal shutdown might occur due to high power dissipation. The specified SPI communication speed is ensured; the absolute maximum ratings are not violated, however the device is not intended for continuous operation of  $V_{SINT} > 28\text{ V}$  and a thermal shutdown might occur due to high power dissipation. The device operation at high junction temperatures for long periods might reduce the operating life time.
- $V_{POR,f} < V_{SINT} < 5.5\text{ V}$  (given the fact that the device was powered up correctly before with  $V_{SINT} > 5.5\text{ V}$ ): Device will still be functional; the specified electrical characteristics might not be ensured anymore:
  - A reset could be triggered depending on the  $V_{rthx}$  settings.
  - The specified SPI communication speed is ensured.

Note:  $V_{s,uv} < V_S < 6.0\text{ V}$ : the charge pump might be deactivated due to a charge pump undervoltage detection, resulting in a turn-off of the external MOSFETs.

**4.3 Thermal Resistance**

**Table 3 Thermal Resistance<sup>1)</sup>**

Parameter	Symbol	Values			Unit	Note or Test Condition	Number
		Min.	Typ.	Max.			
Junction to Soldering Point	$R_{th(JSP)}$	–	7.2	–	K/W	Exposed Pad	P_4.3.1
Junction to Ambient	$R_{th(JA)}$	–	27	–	K/W	<sup>2)</sup>	P_4.3.2

1) Not subject to production test, specified by design.

2) Specified  $R_{th(JA)}$  value is according to Jedec JESD51-2,-5,-7 at natural convection on FR4 2s2p board for a power dissipation of 1.5 W; the product (chip+package) was simulated on a 76.2 x 114.3 x 1.5 mm<sup>3</sup> with 2 inner copper layers (2 x 70 μm Cu, 2 x 35 μm C); where applicable a thermal via array under the exposed pad contacted the first inner copper layer and 300 mm<sup>2</sup> cooling areas on the top layer and bottom layers (70 μm).

**4.4 Current Consumption**

**Table 4 Current Consumption**

Current consumption values are specified at  $T_j = 25^\circ\text{C}$ ,  $V_{SINT} = V_S = 13.5\text{ V}$ , all outputs open (unless otherwise specified)

Parameter	Symbol	Values			Unit	Note or Test Condition	Number
		Min.	Typ.	Max.			
<b>Normal Mode</b>							
Normal Mode current consumption	$I_{Normal}$	–	4.5	5.5	mA	<sup>1)</sup> $V_{SINT} = 5.5\text{ V to }28\text{ V}$ ; $T_j = -40^\circ\text{C to }+150^\circ\text{C}$ ; CP=off	P_4.4.1
Stop Mode current consumption (low active peak threshold)	$I_{Stop_{1,25}}$	–	50	65	μA	<sup>1)2)</sup> CSA=off; WKx=CP=off; Cyclic Wak.=off Watchdog = off; no load on $V_{CC1}$ ; <b>I_PEAK_TH</b> = 0 <sub>B</sub>	P_4.4.2

**General Product Characteristics**

**Table 4 Current Consumption (cont'd)**

Current consumption values are specified at  $T_j = 25^\circ\text{C}$ ,  $V_{\text{SINT}} = V_S = 13.5\text{ V}$ , all outputs open (unless otherwise specified)

Parameter	Symbol	Values			Unit	Note or Test Condition	Number
		Min.	Typ.	Max.			
Stop Mode current consumption (low active peak threshold)	$I_{\text{Stop}_1,85}$	–	55	80	$\mu\text{A}$	<sup>1)2)3)</sup> $T_j = 85^\circ\text{C}$ ; CSA=off; WKx=CP=off; Cyclic Wak.=off Watchdog = off; no load on $V_{\text{CC1}}$ ; <b>I_PEAK_TH</b> = 0 <sub>B</sub>	P_4.4.3
Stop Mode current consumption (high active peak threshold)	$I_{\text{Stop}_2,25}$	–	70	95	$\mu\text{A}$	<sup>1)2)</sup> CSA=off; WKx=CP=off: Cyclic Wak.=off Watchdog = off; no load on $V_{\text{CC1}}$ ; <b>I_PEAK_TH</b> = 1 <sub>B</sub>	P_4.4.4
Stop Mode current consumption (high active peak threshold)	$I_{\text{Stop}_2,85}$	–	75	105	$\mu\text{A}$	<sup>1)2)3)</sup> $T_j = 85^\circ\text{C}$ ; CSA=off; Cyclic Wak.=off; Watchdog = off; no load on $V_{\text{CC1}}$ ; <b>I_PEAK_TH</b> = 1 <sub>B</sub>	P_4.4.5

**Sleep Mode**

Sleep Mode current consumption	$I_{\text{Sleep},25}$	–	18	30	$\mu\text{A}$	<sup>1)</sup> CSA=off; WKx=HSx=CP=off: Cyclic Wak.= off	P_4.4.6
Sleep Mode current consumption	$I_{\text{Sleep},85}$	–	28	40	$\mu\text{A}$	<sup>1)3)</sup> $T_j = 85^\circ\text{C}$ ; CSA=off; WKx=HSx=CP=off: Cyclic Wak.=off	P_4.4.7

**Feature Incremental Current Consumption**

Current consumption for each WK input	$I_{\text{WK,wake},25}$	–	0.2	2	$\mu\text{A}$	<sup>1)4)5)6)</sup> Sleep Mode; WK wake capable; no activity on WK pin;	P_4.4.22
Current consumption for each WK input	$I_{\text{WK,wake},85}$	–	0.5	3	$\mu\text{A}$	<sup>1)3)4)5)6)</sup> Sleep Mode; $T_j = 85^\circ\text{C}$ ; WK wake capable; no activity on WK pin;	P_4.4.23
Current consumption for watchdog active in Stop Mode	$I_{\text{Stop},\text{WD}25}$	–	18	23	$\mu\text{A}$	<sup>3)7)</sup> Stop Mode; Watchdog running;	P_4.4.28
Current consumption for watchdog active in Stop Mode	$I_{\text{Stop},\text{WD}85}$	–	19	25	$\mu\text{A}$	<sup>3)7)</sup> Stop Mode; $T_j = 85^\circ\text{C}$ ; Watchdog running;	P_4.4.29

**General Product Characteristics**

**Table 4 Current Consumption (cont'd)**

Current consumption values are specified at  $T_j = 25^\circ\text{C}$ ,  $V_{\text{SINT}} = V_S = 13.5\text{ V}$ , all outputs open (unless otherwise specified)

Parameter	Symbol	Values			Unit	Note or Test Condition	Number
		Min.	Typ.	Max.			
Current Sense Amplifier	$I_{\text{CSA1}}$	–	–	4	mA	<sup>7)</sup> <b>CSA_OFF</b> = 0 <sub>B</sub> ; VCSP = VCSAP = VCSAN = 0 V; <b>CSO_CAP</b> = 0 <sub>B</sub> ; CCSO = 330 pF	P_4.4.31
Current Sense Amplifier	$I_{\text{CSA2}}$	–	–	10	mA	<sup>7)</sup> <b>CSA_OFF</b> = 0 <sub>B</sub> ; VCSP = VCSAP = VCSAN = 0 V; <b>CSO_CAP</b> = 1 <sub>B</sub> ; CCSO = 2.2 nF	P_4.4.36
Current consumption in parking braking mode (LSx ON)	$I_{\text{parking}}$	–	10	14	μA	<sup>3)7)</sup> Stop Mode or Sleep Mode; $T_j < 85^\circ\text{C}$ ; <b>PARK_BRK_EN</b> = 1 <sub>B</sub>	P_4.4.32
Current consumption Over voltage braking mode (LSx OFF)	$I_{\text{OV,LS\_OFF}}$	–	7	10	μA	<sup>3)7)</sup> Stop Mode or Sleep Mode; $T_j < 85^\circ\text{C}$ ; <b>OV_BRK_EN</b> = 1 <sub>B</sub>	P_4.4.34
Current consumption in VS for Charge Pump and Bridge Driver	$I_{\text{CP,BD}}$	–	30	40	mA	Normal Mode; $T_j = -40^\circ\text{C}$ to $+150^\circ\text{C}$ ; <b>CPEN</b> = 1; All HB OFF	P_4.4.35

- 1) Measured at  $V_{\text{SINT}}$ .
- 2) If the load current on  $V_{\text{CC1}}$  will exceed the configured  $V_{\text{CC1}}$  active peak threshold, the current consumption will increase by typ. 2.9 mA to ensure optimum dynamic load behavior. See also [Chapter 6](#).
- 3) Not subject to production test, specified by design.
- 4) Current consumption adders of features defined for Stop Mode also apply for Sleep Mode and vice versa. Wake input signals are stable (i.e. not toggling), cyclic wake & watchdog are OFF (unless otherwise specified).
- 5) No pull-up or pull-down configuration selected.
- 6) The specified WKx current consumption adder for wake capability applies regardless how many WK inputs are activated.
- 7) Additional current will be drawn from  $V_{\text{SINT}}$ .

**Notes**

1. There is no additional current consumption contribution in Normal Mode due to PWM generators or Timers.
2. The quiescent current consumption in Stop Mode and Sleep Mode will increase for  $V_{\text{SINT}} < 9\text{ V}$ .

## **5 System Features**

This chapter describes the system features and behavior of the TLE9185QXW:

- State machine
- Device configuration
- State machine modes and mode transitions
- Wake-up features such as cyclic wake

### **5.1 Short State Machine Description**

The BLDC Driver offers six operating modes:

- Init Mode: Power-up of the device and after a soft reset.
- Normal Mode: The main operating mode of the device.
- Stop Mode: The first-level power saving mode with the main voltage regulator VCC1 enabled.
- Sleep Mode: The second-level power saving mode with VCC1 disabled.
- Restart Mode: An intermediate mode after a wake event from Sleep Mode or Fail-Safe Mode or after a failure (e.g. WD failure, VCC1 under voltage reset).
- Fail-Safe Mode: A safe-state mode after critical failures (e.g. Temperature shutdown) to bring the system into a safe state and to ensure a proper restart of the system.

A special mode, called Software Development Mode, is available during software development or debugging of the system. All above mentioned operating modes can be accessed in this mode. However, the watchdog is still running. Watchdog failures are indicated over INTN pin instead.

However, the watchdog reset signaling can be reactivated again in Software Development Mode. The Watchdog will start always with the Long Open Windows ( $t_{low}$ ).

The BLDC Driver is controlled via a 32-bit SPI interface (refer to [Chapter 11](#) for detailed information). The configuration as well as the diagnosis is handled via the SPI.

The device offers various supervision features to support functional safety requirements. Refer to [Chapter 10](#) for more information.



**System Features**

**5.2 Device Configuration**

Two features on the BLDC Driver can be configured by hardware:

- The selection of the normal device operation or the Software Development Mode.
- Enabling/disabling the CRC on the SPI interface.

The configurations are done monitoring the follow pins:

- INTN/TEST
- PWM1/CRC

The hardware configuration can be done typically at device power-up, where the device is in Init Mode or (only in case of CRC setting) in Restart Mode.

**Software development Mode configuration detail**

After the RSTN is released, the INTN/TEST pin is internally pulled HIGH with a weak pull-up resistor. Therefore the default configuration is the device in normal operation.

In order to configure the Software Development Mode, the following conditions have to be fulfilled:

- Init Mode from power-up
- $VCC1 > V_{rtx}$
- **POR**=1
- RSTN = HIGH

The Software Development Mode is configured using the following scheme:

- Only one external pull-down on INTN/TEST pin followed by an arbitrary SPI command, the device latches the Software Development Mode.
- External pull-up or no pull-down on INTN/TEST pin enable the device in normal operation.
- To enter Software Development Mode, a pull-down resistor to GND might be used.

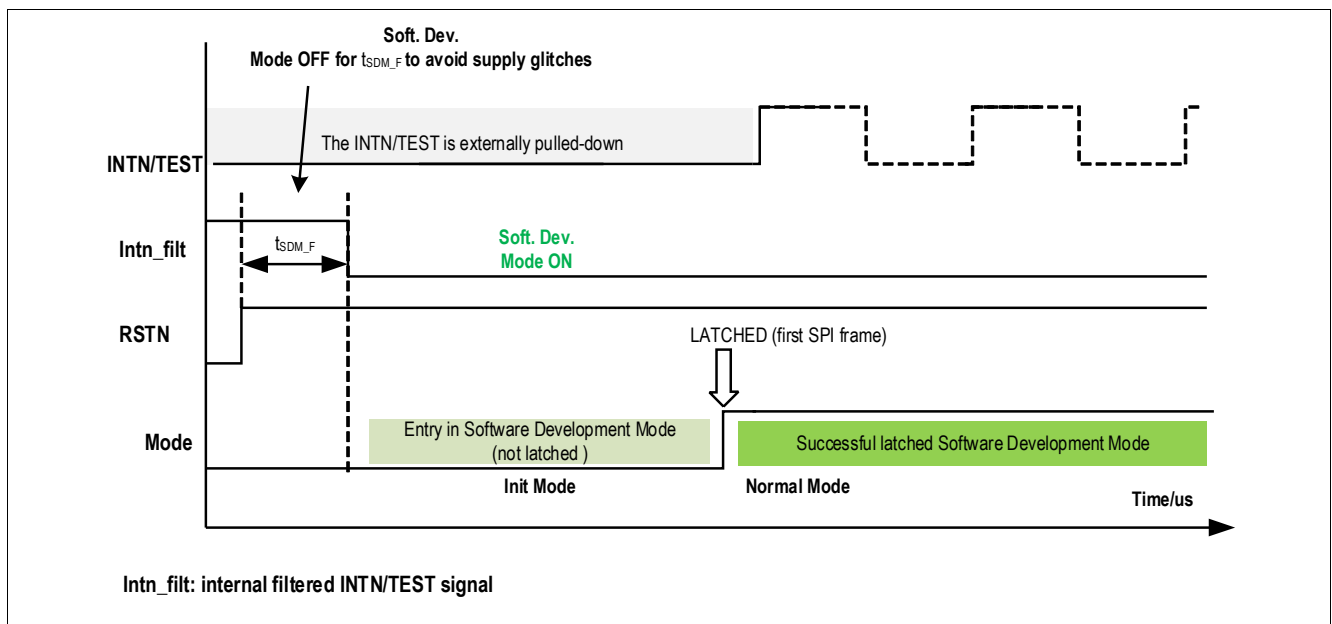

Intn\_filt is a filtered signal from INTN/TEST, with the filter time  $t_{SMD\_F}$  (P\_11.2.7). Intn\_filt starts (at the rising edge if RSNT) with the value 1.

**System Features**

*Note: If during monitoring the INTN/TEST pin for Software Development Mode entry, the device changes the mode without SPI command, the device will not enter/stay in Software Development Mode.*

**CRC configuration detail**

The CRC is configured using the following scheme:

- Pull-down on PWM1/CRC enable the CRC.
- No external components on PWM1/CRC disables the CRC.

In order to configure the CRC, the follow conditions have to be full filled:

- Init Mode (from power-up) or Restart Mode
- $VCC1 > V_{rtx}$
- **POR**=1
- **RSTN** = LOW

The configuration selection is done during the reset delay time  $t_{RD1}$  with a continuous filter time of  $t_{CFG\_F}$  and the configuration (depending on the voltage level at PWM1/CRC) is latched at the rising edge of RSTN.

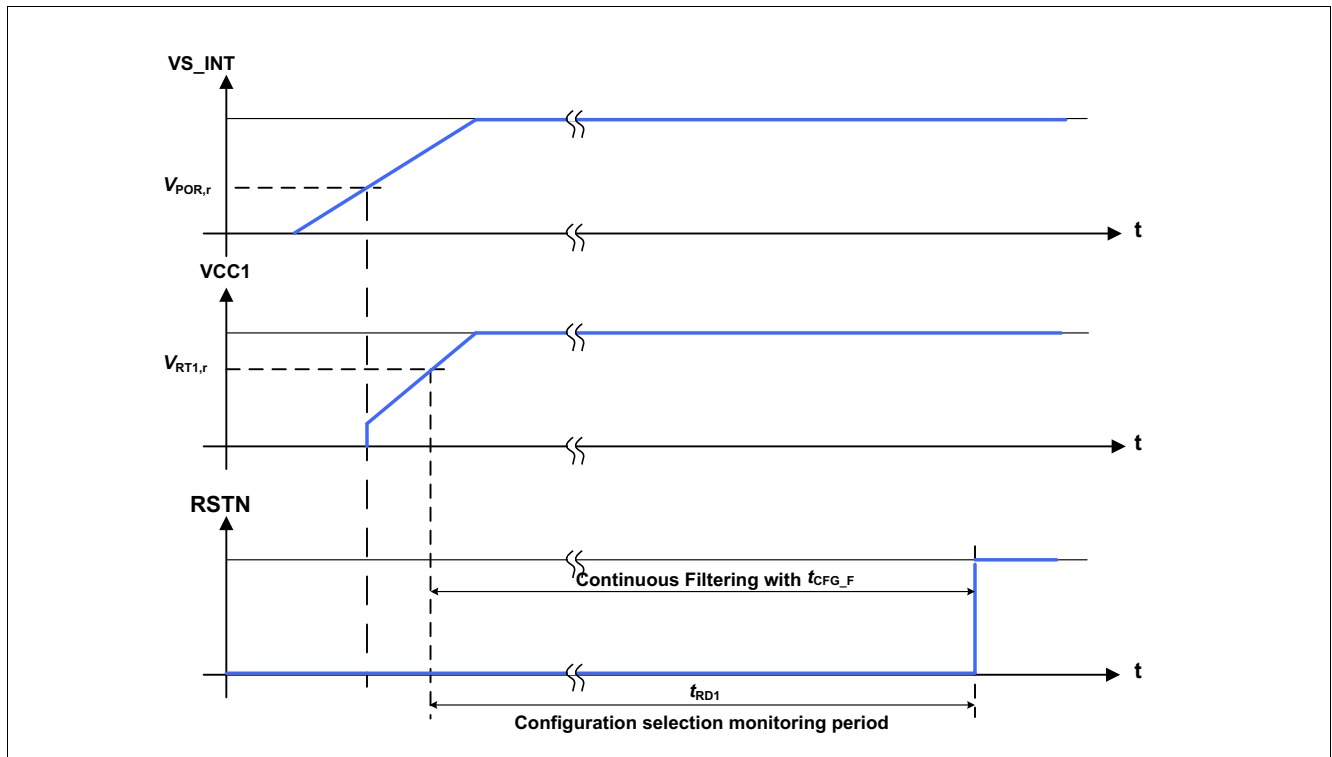

**Figure 4 CRC configuration Selection Timing Diagram at the device power-up.**

In case of mismatch between CRC setting between the device and  $\mu C$  (**CRC\_STAT**), the device can accept two recovery SPI commands (static patterns).

The pattern 67AA AA0E<sub>H</sub> (addr + rw\_bit = 67 ; data = AAAA ; CRC = 0E ) enables the CRC.

The pattern E7AA AAC3<sub>H</sub> (addr + rw\_bit = E7 ; data = AAAA ; CRC = C3) disables the CRC.

The patterns shall be send only in Normal Mode.

For additional details about the CRC setting and configuration, refer also to **Chapter 11.3.1**.

System Features

5.3 Block Description of State Machine

The state machine describes the different states of operation, the device may get into. The following figure shows the state machine flow diagram.

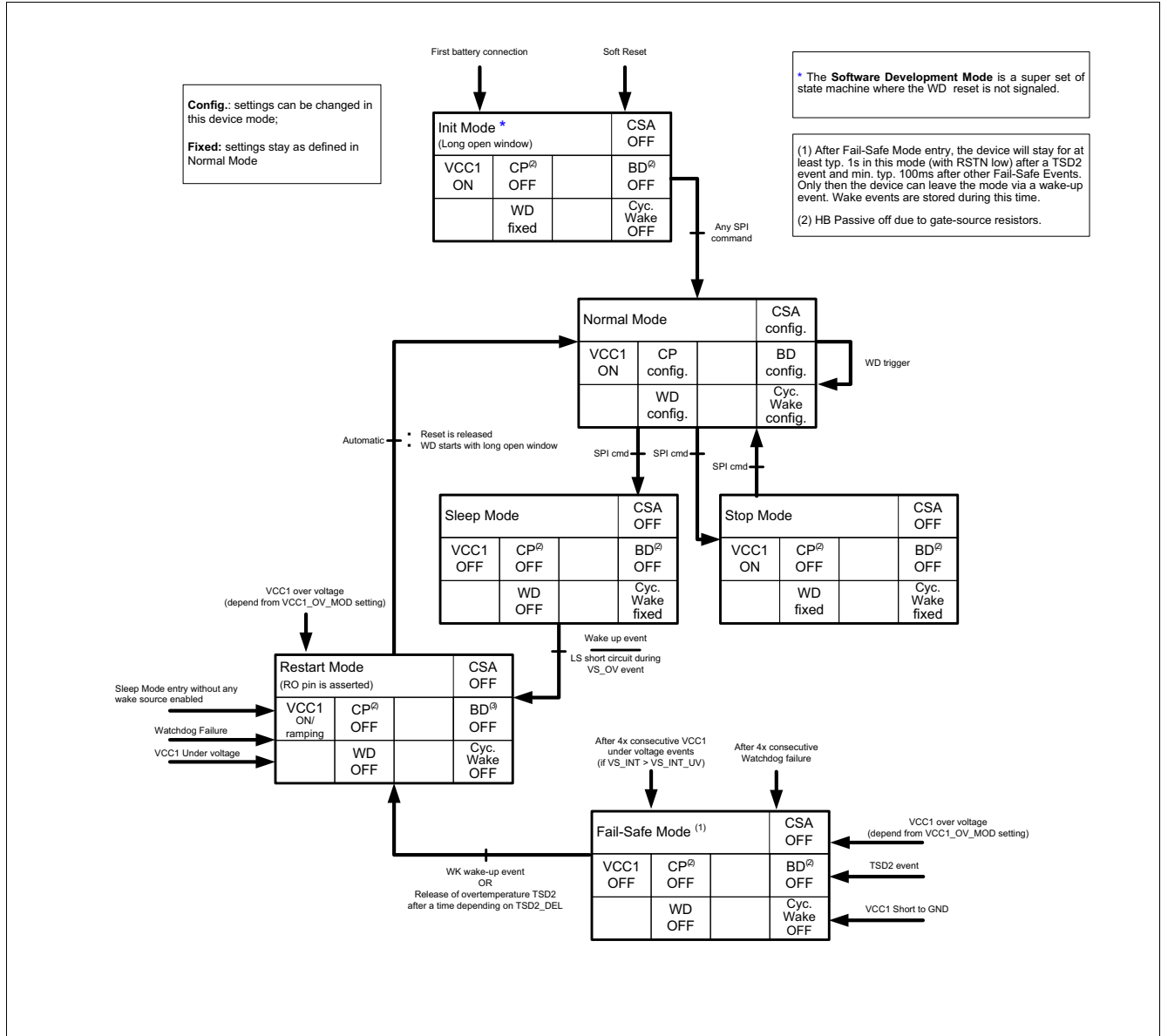

Figure 5 State Diagram showing the operating modes

Description:

- ON /OFF:= Indicate if the module is enabled or disabled either via SPI or from the device itself
- config:= Settings can be changed in this mode
- fixed:= Settings stay as defined in Normal Mode or Init Mode
- active/inactive:= Indicate if the device activates/deactivates one specific feature

System Features

## 5.4 State Machine Modes Description

### 5.4.1 Init Mode

The device starts up in Init Mode after crossing the power-on reset  $V_{POR,r}$  threshold (see also [Chapter 10.3](#)) and the watchdog will start with a long open window ( $t_{LW}$ ) after RSTN is released (High level).

In Init Mode, the device waits for the microcontroller to finish its startup and initialization sequence.

Init Mode (Long open window)			
VCC1 ON	CP OFF		BD OFF
CSA OFF	WD fixed		Cyc. Wake OFF

Figure 6 Init Mode

Table 5 Init Mode Settings

Part/Function	Value	Description
VCC1	ON	• The VCC1 is ON
WD	fixed	• Watchdog is fixed and set with a long open window ( $t_{LW}$ )
BD	OFF	• Bridge Drivers is OFF
CP	OFF	• Charge Pump is OFF
CSA	OFF	• Current Sense Amplifier is OFF
Cyc Wake	OFF	• Cycle Wake is OFF

### 5.4.2 Normal Mode

The Normal Mode is the standard operating mode for the device. The VCC1 is active and all features are configurable. Supervision and monitoring features are enabled.

Normal Mode			
VCC1 ON	CP config.		BD config.
CSA config.	WD config.		Cyc. Wake config.

Figure 7 Normal Mode

**System Features**

**Table 6 Normal Mode Settings**

Part/Function	Value	Description
VCC1	ON	• VCC1 is active
WD	config	• Watchdog may be configured by SPI
BD/CP	config	• The Bridge Drivers and Charge Pump may be configured and switched ON or OFF by SPI
CSA	config	• Current Sense Amplifier may be configurable and switched ON or OFF by SPI
Cyc. Wake	config	• Cyclic wake can be configured with the Timer1 or Timer 2

**5.4.3 Stop Mode**

The Stop Mode is the first level technique to reduce the overall current consumption VCC1 into a low-power mode.

*Note: All settings have to be done before entering Stop Mode.*

In Stop Mode any kind of SPI WRITE commands are ignored and the **SPI\_FAIL** bit is set, except for changing to Normal Mode, triggering a device Soft Reset, refreshing the watchdog as well as for reading and clearing the SPI status registers.

*Note: A wake-up event on , WKx, Low-Side short circuit detection in parking braking mode or overvoltage brake detection, could generate an interrupt on pin INTN (based on INTN masking configuration; refer to **Chapter 8**) however, no change of the device mode will occur.*

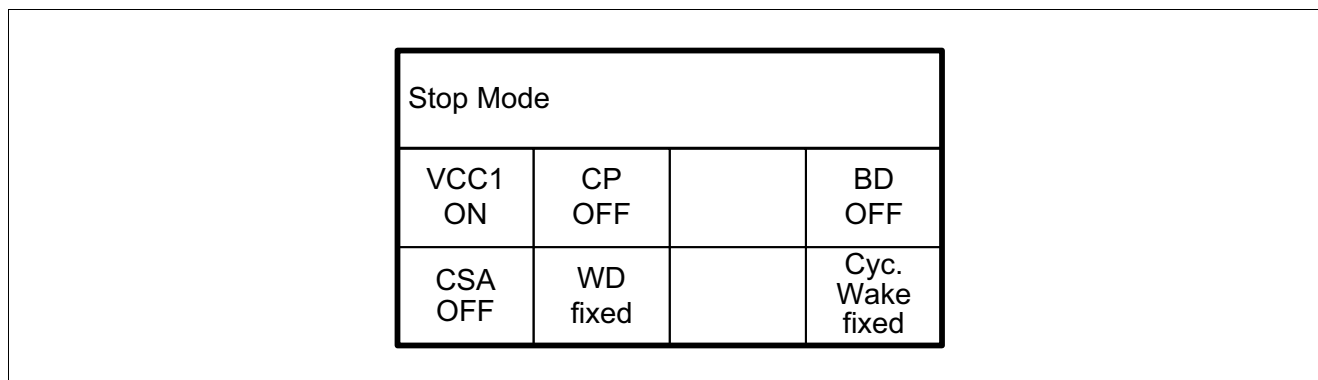

**Figure 8 Stop Mode**

**Table 7 Stop Mode Settings**

Part/Function	Value	Description
VCC1	ON	• VCC1 is ON
WD	fixed	• Watchdog is fixed as configured in Normal Mode
BD/CP	OFF	• The Bridge Drivers and Charge Pump are OFF
CSA	OFF	• Current Sense Amplifier is OFF
Cyc. Wake	fixed	• Cyclic wake is fixed as configured in Normal Mode

**System Features**

*Note:* In Stop Mode, it is possible to activate the Low-Side of Bridge Drivers (e.g. in case of parking braking mode or overvoltage brake detection). Refer to [Chapter 10.9](#) for additional details.

**5.4.4 Sleep Mode**

The Sleep Mode is the second level technique to reduce the overall current consumption to a minimum needed to react on wake-up events or for the device to perform autonomous actions .

*Note:* All settings have to be done before entering Sleep Mode.

Sleep Mode			
VCC1 OFF	CP OFF		BD OFF
CSA OFF	WD OFF		Cyc. Wake fixed

**Figure 9 Sleep Mode**

**Table 8 Sleep Mode Settings**

Part/Function	Value	Description
VCC1	OFF	• VCC1 is OFF
WD	OFF	• Watchdog is OFF
BD/CP	OFF	• The Bridge Drivers and Charge Pump are OFF
CSA	OFF	• Current Sense Amplifier is OFF
Cyc. Wake	fixed	• Cyclic wake is fixed

*Note:* In Sleep Mode, it is possible to activate the Low-Side’s of Bridge Drivers (e.g. in case of parking braking mode or overvoltage braking). Refer to [Chapter 10.9](#) for additional details.

**5.4.5 Restart Mode**

The Restart Mode is a transition state where the RSNT pin is asserted.

Restart Mode (RO pin is asserted)			
VCC1 ON/ ramping	CP OFF		BD OFF
CSA OFF	WD OFF		Cyc. Wake OFF

**Figure 10 Restart Mode**

**System Features**

**Table 9 Restart Mode Settings**

Part/Function	Value	Description
VCC1	ON/ ramping	• VCC1 is ON or ramping up
WD	OFF	• WD will be disabled if it was activated before
BD/CP	OFF	• The Bridge Drivers and Charge Pump are OFF
CSA	OFF	• Current Sense Amplifier is OFF
Cyc. Wake	OFF	• Cyclic wake will be disabled if it was activated before

**5.4.6 Fail-Safe Mode**

The purpose of this mode is to bring the system in a safe status after a failure condition by turning OFF VCC1 . After a wake event the system is then able to restart again.

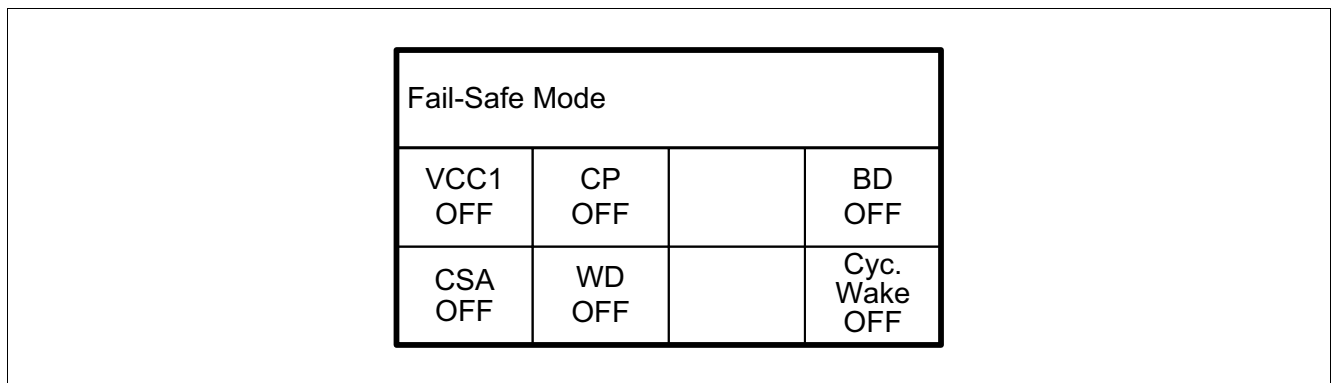

**Figure 11 Fail-Safe Mode**

**Table 10 Fail-Safe Mode Settings**

Part/Function	Value	Description
VCC1	OFF	• VCC1 is switched OFF
WD	OFF	• WD is switched OFF
BD/CP	OFF	• The Bridge Drivers and Charge Pump are OFF
CSA	OFF	• Current Sense Amplifier is OFF
Cyc. Wake	OFF	• Cyclic wake is switched OFF

**Note**

- In Fail-Safe Mode, the default wake sources WKx (if configured as wake inputs) are activated automatically and all wake event bits will be cleared.
- The Fail-Safe Mode will be maintained until a wake event on the default wake sources occurs. To avoid any fast toggling behavior a filter time of typ. 100ms ( $t_{FS,min}$ ) is implemented. Wake events during this time will be stored and will automatically lead to entering Restart Mode after the filter time.  
 In case of an VCC1 overtemperature shutdown (TSD2) the Restart Mode will be reached automatically after a filter time of typ. 1s ( $t_{TSD2}$ ) without the need of a wake event once the device temperature has fallen below the TSD2 threshold.
- The parking braking mode is automatically disabled in Fail-Safe Mode.

**System Features**

**5.4.7 Software Development Mode**

The Software Development Mode is a dedicated device configuration especially useful for software development.

Compared to the default device user mode operation, this mode is a super set of the state machine. The device will start also in Init Mode and it is possible to use all the modes and functions with following differences:

- Restart Mode or Fail-Safe Mode (depending on the configuration) is not reached due to watchdog failure but the other reasons to enter these modes are still valid.

**Table 11 Normal Mode Settings (Software Development Mode active)**

Part/Function	Default State	Description
VCC1	ON	• VCC1 is active
WD	ON	• WD is on, but will not trigger transition to Fail-Safe Mode or Restart Mode
BD/CP	OFF	• The Bridge Drivers and Charge Pump may be configured and switched ON or OFF by SPI
Cyc. Wake	OFF	• Can be configured

**Software Development Mode entry**

For timing and configuration details, refer to [Chapter 5.2](#).

**Note**

- After Init Mode, the pull-up is released as the INTN/TEST pin acts as output then to drive the INTN signal.
- If the device enters Fail-Safe Mode due to VCC1 short circuit to GND during the Init Mode, the Software Development Mode will not be entered and can only be reached at the next power-up of the device after the VCC1 short circuit is removed.
- The absolute maximum ratings of the pin INTN must be observed. To increase the robustness of this pin during debugging or programming a series resistor between INTN and the connector can be added.

**Watchdog in Software Development Mode**

The Watchdog is enabled in Software Development Mode as default state. One INTN event is generated due to wrong watchdog trigger.

It is possible to deactivate the integrated Watchdog module using the [WD\\_SDM\\_DISABLE](#) bit. After disabling the Watchdog, no INTN events are generated and the [WD\\_FAIL](#) bit will also not be set anymore in case of a trigger failure. It is also possible only to mask / unmask the INTN event of the WD in Software Development Mode by using the bit [WD\\_SDM](#). In case of unmasking, a WD trigger fail will only lead to [WD\\_FAIL](#) bit set.

**5.5 Transition Between States**

This chapter describes the transition between the modes triggered by power-up, SPI commands or wake-up events.

**5.5.1 Transition into Init Mode**

The device goes into Init Mode in case of a power-up or after sending a soft-reset in Normal or Stop Mode.

**Prerequisites:**

- Power OFF



## System Features

- Device in Normal Mode or Stop Mode with follow conditions:
  - VSINT > VPOR,r
  - RSTN High

### Triggering Events:

- A Soft Reset command (**MODE** = '11'). All SPI registers will be changed to their respective Soft Reset values.

### Note

- In case of Soft Reset command, a hardware RSTN event can be generated depending on the configuration. An external Reset will be generated in case of **SOFT\_RESET\_RO** = 0<sub>B</sub>. In case of **SOFT\_RESET\_RO** = 1<sub>B</sub>, no RSTN hardware event is generated in case of Soft Reset.
- At power-up, the SPI bit **VCC1\_UV** will not be set as long as VCC1 is below the VRT,x threshold and if VSINT is below the VSINT,UV threshold. The RSTN pin will be kept LOW as long as VCC1 is below the selected VRT1,r threshold. The reset delay counter will start after VRT1,r threshold is reached. After the first threshold crossing of  $VCC1 > V_{RT1,R}$  and RSTN transition from low to high, all subsequent undervoltage events will lead to Restart Mode.
- Wake events are ignored during Init Mode and will be lost.
- The bit **VSINT\_UV** will only be updated in Init Mode once RSTN resumes a high level.

## 5.5.2 Init Mode -> Normal Mode

This transition moves the device in the mode where all configurations are accessible via SPI command.

### Prerequisites:

- VSINT > VPOR,r
- Init Mode
- RSTN High

### Triggering Events:

- Any valid SPI command (from SPI protocol point of view) will bring the device to Normal Mode (i.e. any register can be written, cleared and read) during the long open window where the watchdog has to be triggered (refer also [Chapter 11.2](#)). The CRC is not taken into account for this transition.
- For example:
  - A SPI Sleep Mode command will still bring the device into Normal Mode. However, as this is an invalid state transition, the SPI bit **SPI\_FAIL** is set.
  - Any invalid SPI command (from content point of view) will still bring the device into Normal Mode. The SPI bit **SPI\_FAIL** is set.

### Note

- It is recommended to use the first SPI command to trigger and to configure the watchdog.

## 5.5.3 Normal Mode -> Stop Mode

This transition is intended as first measure to reduce the current consumption. All the device features needed in Stop Mode shall be configured in Normal Mode.

### Prerequisites:

- VCC1 > Vrtx
- Device in Normal Mode

### Triggering Events:

## System Features

- State transition is only initiated by specific SPI command.

### Note

- An interrupt is triggered on the pin INTN when Stop Mode is entered and not all wake source signalization flags were cleared.
- If high-side switches are kept enabled during Stop Mode, then the device current consumption will increase.
- It is not possible to switch directly from Stop Mode to Sleep Mode. Doing so will also set the **SPI\_FAIL** flag and will bring the device into Restart Mode.

### 5.5.4 Normal Mode -> Sleep Mode

This transition is intended to reduce as much as possible the current consumption keeping active only wake-up sources. All wake-up sources configurations shall be done in Normal Mode.

#### Prerequisites:

- $VCC1 > V_{rtx}$
- Device in Normal Mode
- All wake source signalization flags were cleared (including the LSxDSOV\_BRK bit)
- At least one wake-up source activated

#### Triggering Events:

- State transition is only initiated by specific SPI command.

### Note

- If **VCC1\_UV** or **VCC1\_OV** (with Config to go to Restart Mode) occurs at the border of the Sleep Mode entry: The device will go immediately into Restart Mode.
- If **TSD2** or **VCC1\_OV** (with Config to go to Fail-Safe Mode) occurs at the border of the Sleep Mode entry: The device will enter immediately Fail-Safe Mode.
- As soon as the Sleep Mode command is sent, the Reset will go low.
- It is not possible to switch all wake sources off in Sleep Mode. Doing so will set the **SPI\_FAIL** flag and will bring the device into Restart Mode.

### 5.5.5 Stop Mode -> Normal Mode

This transition is intended to set the device in Normal Mode where all the device integrated features are available and configurable.

#### Prerequisites:

- $VCC1 > V_{rtx}$
- Device in Stop Mode

#### Triggering Events:

- State transition is only initiated by SPI command.

### Note

- None

## System Features

### 5.5.6 Sleep Mode -> Restart Mode

This transition is the consequence of a detection of wake-up event by the device. This transition is used to ramp up VCC1 after a wake in a defined way.

#### Prerequisites:

- Device in Sleep Mode
- At least one wake-up source active

#### Triggering Events:

- A wake-up event on WKx, Cyclic Wake.
- Bridge driver low-side short circuit detected during overvoltage braking or in parking braking mode.

#### Note

- It is not possible to switch off all wake sources in Sleep Mode. Doing so will set the **SPI\_FAIL** flag and will bring the device into Restart Mode.
- RSTN is pulled low during Restart Mode.
- The Restart Mode entry is signalled in the SPI register **DEV\_STAT**.
- The wake-up events are flagged in **WK\_STAT** register or **DSOV** register.

### 5.5.7 Restart Mode -> Normal Mode

From Restart Mode, the device goes automatically to Normal Mode.

#### Prerequisites:

- Device in Sleep Mode or Fail-Safe Mode

#### Triggering Events:

- Automatic
- Reset is released

#### Note

- The watchdog timer will start with a long open window starting from the moment of the rising edge of RSTN and the watchdog period setting in the register **WD\_CTRL** will be changed to the respective default value.

### 5.5.8 Fail-Safe Mode -> Restart Mode

This transition is similar to device from Sleep Mode to Restart Mode and consequence of a detection of wake-up event by the device. This transition is used to ramp up VCC1 after a wake in a defined way.

#### Prerequisites:

- Device in Fail-Safe Mode

#### Triggering Events:

- A wake-up event on WKx, TSD2 (released over temperature TDS2 after  $t_{TSD2}$ ).
- Bridge Driver Low Side short circuit detected during VS/VSINT overvoltage braking mode or in parking braking mode.

*Note:* After leaving Fail-Safe Mode, the **FAILURE** bit in **DEV\_STAT** register is set.

System Features

5.6 Reaction on Detected Faults

The device can react at some critical events either signalling the specific failure or changing the device mode. The chapter describes actions taken from the device in case of critical events in particular related the device mode change.

5.6.1 Stay in Current State

The following failures will not trigger any device mode changes, but will indicate the failures by an INTN event (depending from the Interrupt Masking) and in dedicated status registers:

- Failures in Bridge Driver and/or Charge Pump

5.6.2 Transition into Restart Mode

The Restart Mode can be entered in case of failure as shown in following figure.

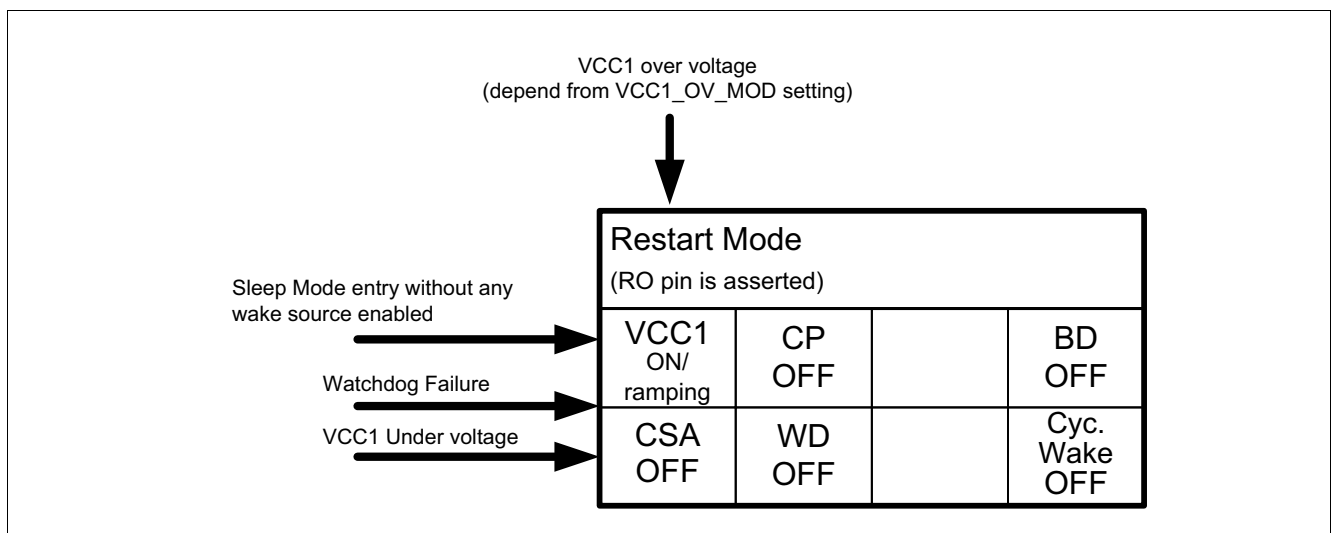

Figure 12 Move into Restart Mode

Prerequisites

- In case of wake-up event from Sleep Mode or Fail Safe Mode
- In case of Normal Mode
- In case of Stop Mode

Trigger Events

- VCC1 Undervoltage in case of Normal Mode or Stop Mode.
- Watchdog trigger failure in case of Normal Mode or Stop Mode.
- VCC1 Overvoltage (based on **VCC1\_OV\_MOD**) in case of Normal Mode or Stop Mode.
- Sleep Mode entry without any wake-up sources enabled in Normal Mode or Stop Mode.

Note

- None

System Features

### 5.6.3 Transition into Fail-Safe Mode

The Fail-Safe Mode can be entered in case of critical event as shown in the following figure.

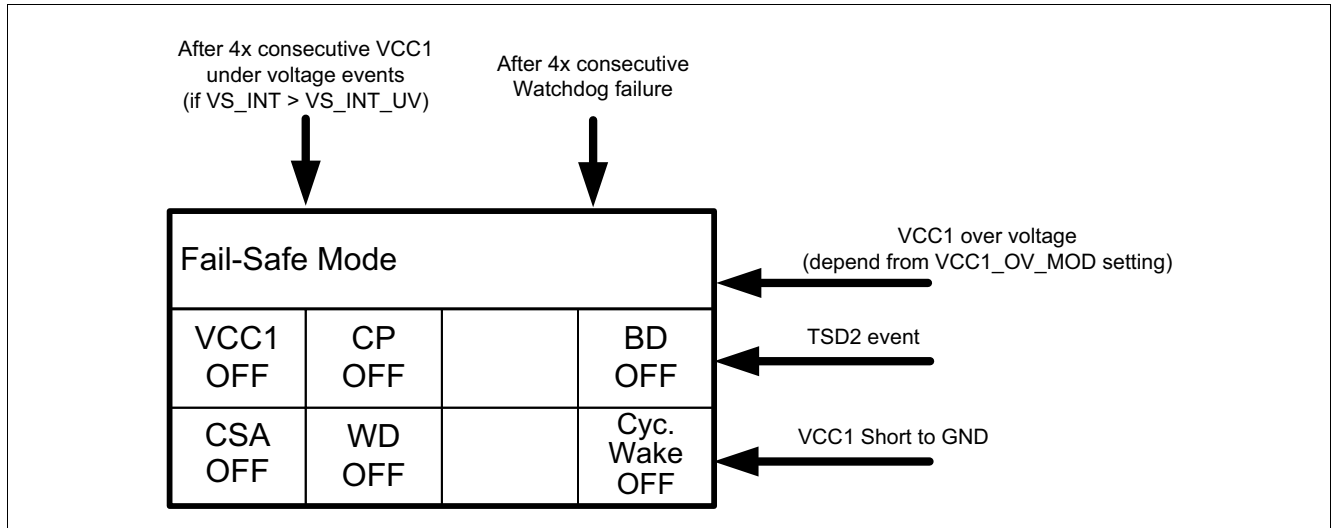

Figure 13 Move into Fail-Safe Mode

**Prerequisites:**

- Critical events on VCC1
- Watchdog trigger failures

**Trigger Events:**

- Device thermal shutdown (TSD2) (see also [Chapter 10.8.3](#)).
- VCC1 is shorted to GND (see also [Chapter 10.7](#)).
- VCC1 over voltage (based on [VCC1\\_OV\\_MOD](#)).
- 4 consecutive Watchdog trigger failure.
- 4 consecutive VCC1 under voltage events.

## 5.7 Wake Features

Following wake sources are implemented in the device:

- Static Sense: WKx inputs are permanently active as wake sources.
- Cyclic Wake: wake controlled by internal timers, wake inputs are not used for cyclic wake.

### 5.7.1 Cyclic Wake

For the cyclic wake feature one timer is configured as internal wake-up source and will periodically trigger an interrupt on INTN in Normal Mode and Stop Mode. During Sleep Mode, the timer triggers and wakes up the device again. The device enters via Restart Mode the Normal Mode.

The correct sequence to configure the cyclic wake is shown in [Figure 14](#). The sequence is as follows:

System Features

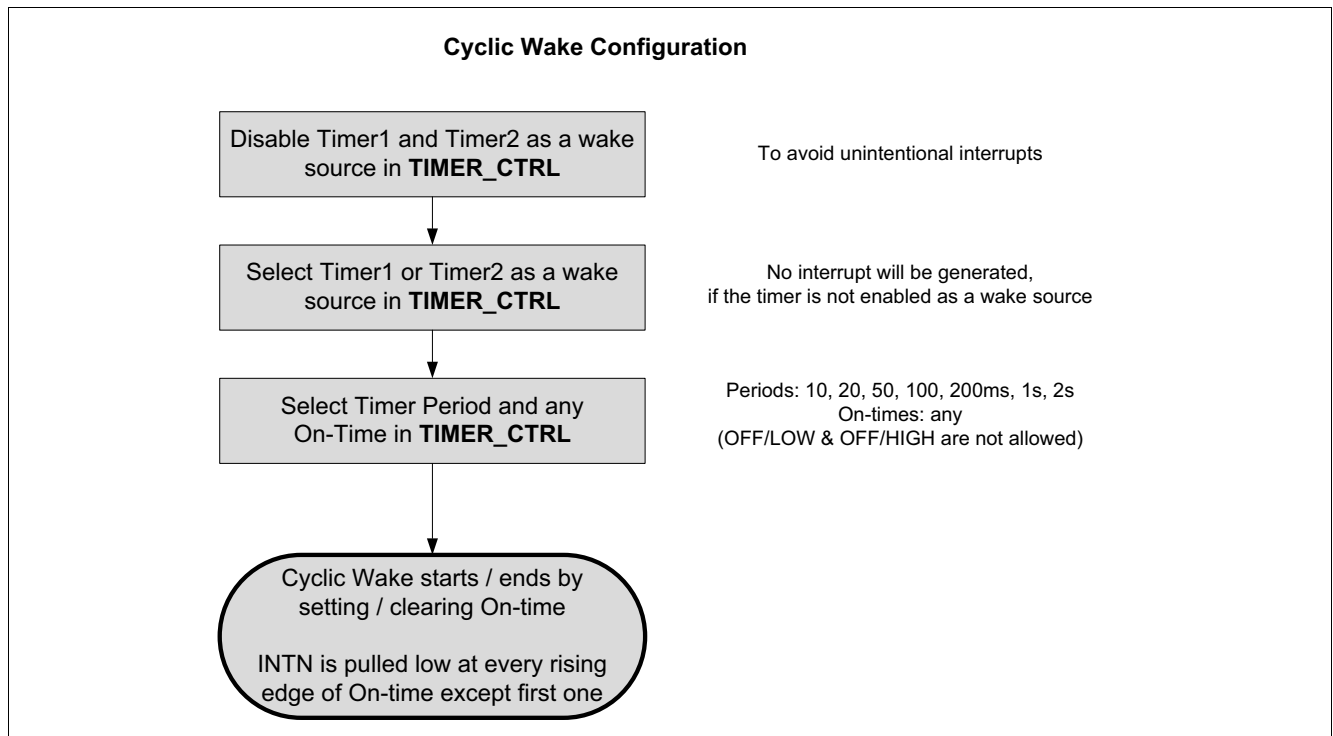

**Figure 14 Cyclic Wake: Configuration and Sequence**

*Note: The on-time is only used to enable the cyclic wake function regardless of the value of the on time, i.e. the on time value has no meaning to the cyclic wake function as long as it is not '000' or '110' or '111'.*

The cyclic wake function will start as soon as the on-time is configured. An interrupt is generated for every start of the on-time except for the very first time when the timer is started.

### 5.7.2 Internal Timers

Two integrated timers can be used to control the below features:

- Cyclic Wake, i.e. to wake up the microcontroller periodically in Normal Mode, Stop Mode and Sleep Mode.

## 5.8 VS Supply Multiplexing

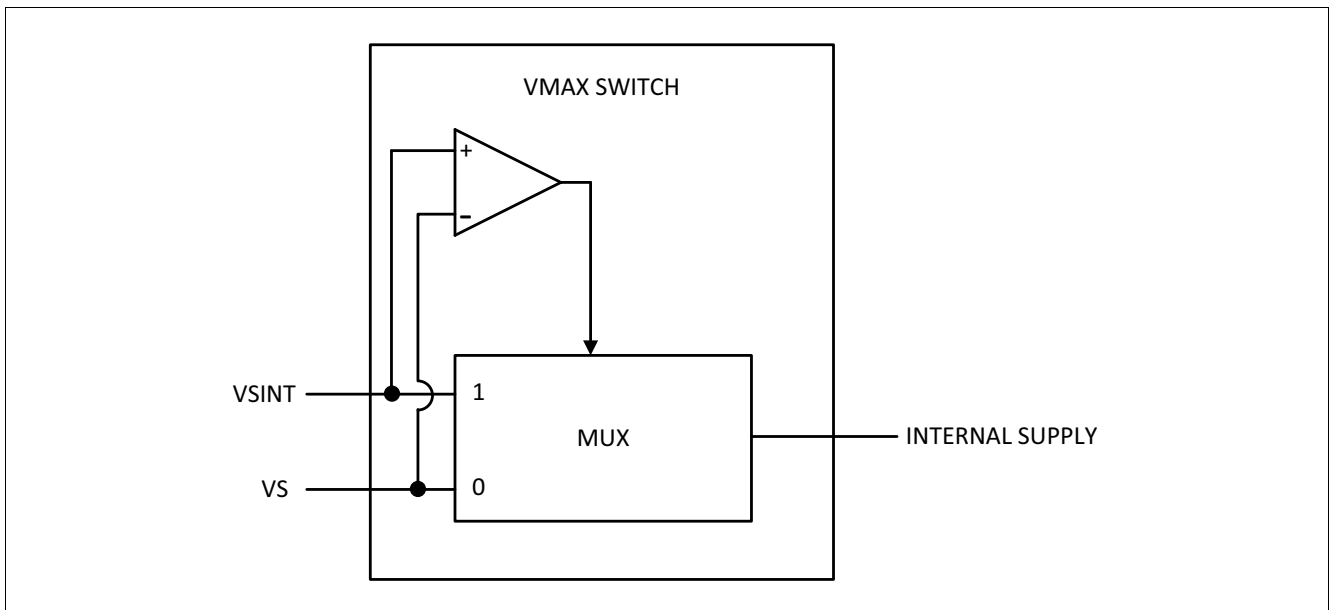

**Figure 15 VS Supply Multiplexing**

The internal supply voltage is multiplexed from VSINT and VS, choosing continuously the larger of both. In case of transient low VBAT, the buffered supply voltage takes over the internal supply, avoiding loss of power.

*Note: Only the internal digital logic of the device is supplied by the VMAX SWITCH. In case of a power loss of either VS or VSINT, the internal register values will not be lost.*

Voltage Regulator 1

## 6 Voltage Regulator 1

VCC1 is a voltage reference for the current sense amplifier, for the SPI interface and for the PWM inputs. VCC1 has its own internal voltage regulator and may not be connected to the output of another voltage regulator.

### 6.1 Block Description

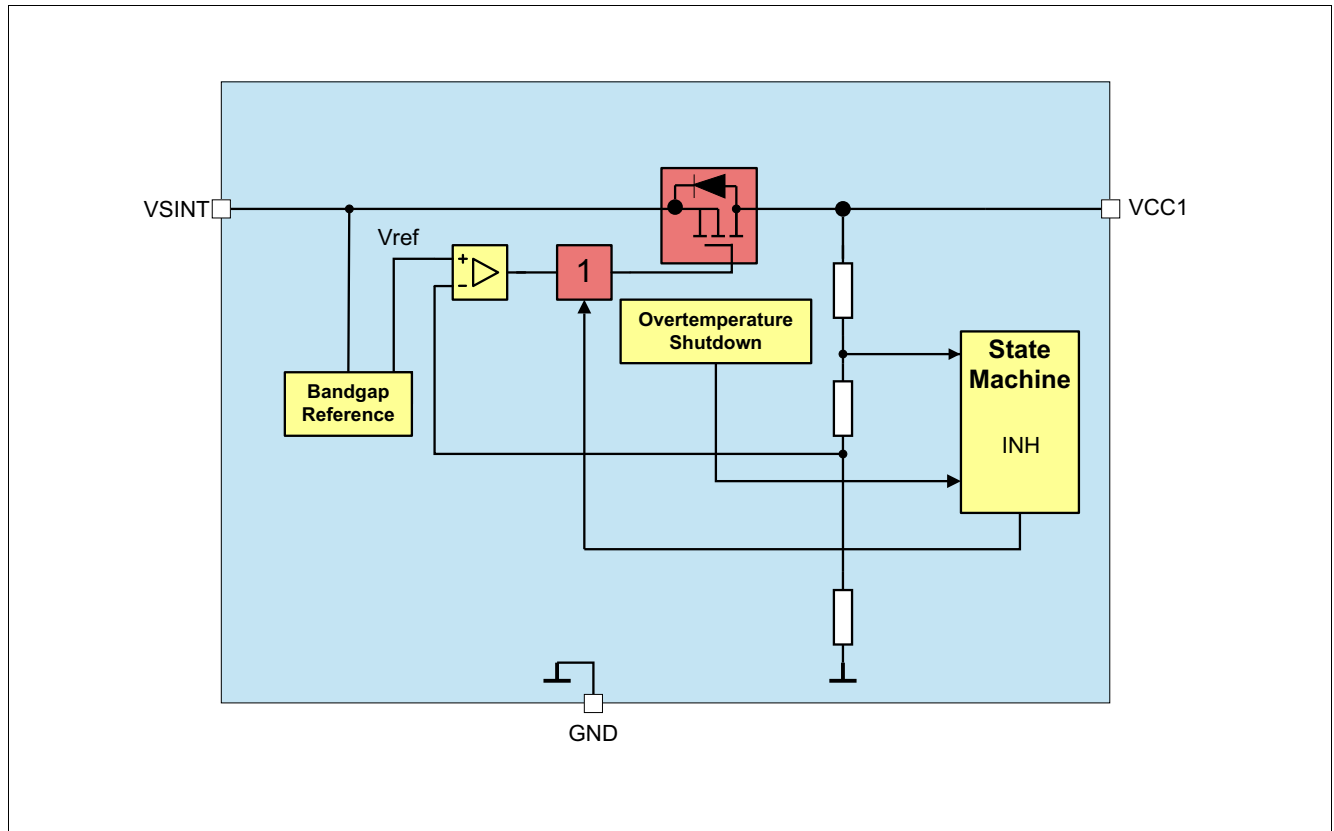

Figure 16 Module Block Diagram

#### Functional Features

- 5 V low-drop voltage regulator.
- Undervoltage monitoring with adjustable reset level and VCC1 undervoltage prewarning (refer to [Chapter 10.6](#) and [Chapter 10.7](#) for more information).
- Short circuit detection and switch off with undervoltage fail threshold, device enters Fail-Safe Mode.
- Effective capacitance must be  $\geq 1 \mu\text{F}$  at nominal voltage output for stability. A  $2.2 \mu\text{F}$  ceramic capacitor (MLCC) is recommended for best transient response.
- Output current capability up to  $I_{VCC1,lim}$ .



## Voltage Regulator 1

### 6.2 Functional Description

The Voltage Regulator 1 (=VCC1) is “ON” in Normal Mode and Stop Mode and is disabled in Sleep Mode and in Fail-Safe Mode. The regulator can provide an output current up to  $I_{VCC1,lim}$ .

For low-quiescent current reasons, the output voltage tolerance is decreased in Stop Mode because only the less accurate low-power mode regulator will be active for small loads. If the load current on VCC1 exceeds the selected threshold ( $I_{VCC1,peak1,r}$  or  $I_{VCC1,peak2,r}$ ) then the high-power mode regulator will be also activated to support an optimum dynamic load behavior. The current consumption will then increase (approx. 2.8 mA additional quiescent current). The device mode stays unchanged.

If the load current on VCC1 falls below the selected threshold ( $I_{VCC1,peak1,f}$  or  $I_{VCC1,peak2,f}$ ), then the low-quiescent current mode is resumed again by disabling the high-power mode regulator.

Both regulators (low-power mode and high-power mode) are active in Normal Mode.

Two different active peak thresholds can be selected via SPI:

- **I\_PEAK\_TH** = ‘0’ (default): the lower VCC1 active peak threshold 1 is selected with lowest quiescent current consumption in Stop Mode.
- **I\_PEAK\_TH** = ‘1’: the higher VCC1 active peak threshold 2 is selected with an increased quiescent current consumption in Stop Mode.

**Voltage Regulator 1**

**6.3 Electrical Characteristics**

**Table 12 Electrical Characteristics**

$V_{SINT} = 5.5\text{ V to }28\text{ V}$ ;  $T_j = -40^\circ\text{C to }+175^\circ\text{C}$ ; all voltages with respect to ground, positive current flowing into pin (unless otherwise specified).

Parameter	Symbol	Values			Unit	Note or Test Condition	Number
		Min.	Typ.	Max.			
Output Voltage including Line and Load Regulation	$V_{CC1,out1}$	4.9	5.0	5.1	V	<sup>1)</sup> Normal Mode; $10\ \mu\text{A} < I_{VCC1} < 150\ \text{mA}$ ;	P_6.3.1
Output Voltage including Line and Load Regulation (Full Load Current Range)	$V_{CC1,out2}$	4.9	5.0	5.1	V	<sup>1)</sup> Normal Mode; $6\ \text{V} < V_{SINT} < 28\ \text{V}$ ; $10\ \mu\text{A} < I_{VCC1} < 250\ \text{mA}$	P_6.3.2
Output Voltage including Line and Load Regulation (Higher Accuracy Range)	$V_{CC1,out3}$	4.95	–	5.05	V	<sup>2)</sup> Normal Mode; $20\ \text{mA} < I_{VCC1} < 80\ \text{mA}$ ; $8\ \text{V} < V_{SINT} < 18\ \text{V}$ ; $25^\circ\text{C} < T_j < 150^\circ\text{C}$	P_6.3.3
Output Voltage including Line and Load Regulation (low-power mode)	$V_{CC1,out4}$	4.9	5.05	5.2	V	Stop Mode; $10\ \mu\text{A} < I_{VCC1} < I_{VCC1,peak}$	P_6.3.4
Output Drop Voltage	$V_{CC1,d1}$	–	200	400	mV	$I_{VCC1} = 50\ \text{mA}$ , $V_{SINT} = 5\ \text{V}$	P_6.3.9
Output Drop Voltage	$V_{CC1,d2}$	–	300	500	mV	$I_{VCC1} = 150\ \text{mA}$ , $V_{SINT} = 5\ \text{V}$	P_6.3.10
VCC1 Active Peak Threshold 1 (Transition threshold between low-power and high-power mode regulator)	$I_{VCC1,lpeak1,r}$	–	3.25	6.0	mA	<sup>2)</sup> $I_{CC1}$ rising; $V_{SINT} = 13.5\ \text{V}$ ; <b><math>I\_PEAK\_TH = '0'</math></b>	P_6.3.17
VCC1 Active Peak Threshold 1 (Transition threshold between high-power and low-power mode regulator)	$I_{VCC1,lpeak1,f}$	1.2	1.7	–	mA	<sup>2)</sup> $I_{CC1}$ falling; $V_{SINT} = 13.5\ \text{V}$ ; <b><math>I\_PEAK\_TH = '0'</math></b>	P_6.3.18
VCC1 Active Peak Threshold 2 (Transition threshold between low-power and high-power mode regulator)	$I_{VCC1,lpeak2,r}$	6	–	20	mA	<sup>2)</sup> $I_{CC1}$ rising; $V_{SINT} = 13.5\ \text{V}$ ; <b><math>I\_PEAK\_TH = '1'</math></b>	P_6.3.19
VCC1 Active Peak Threshold 2 (Transition threshold between high-power and low-power mode regulator)	$I_{VCC1,lpeak2,f}$	5	–	15	mA	<sup>2)</sup> $I_{CC1}$ falling; $V_{SINT} = 13.5\ \text{V}$ ; <b><math>I\_PEAK\_TH = '1'</math></b>	P_6.3.20
Overcurrent Limitation	$I_{VCC1,lim}$	260	360	500	mA	current following out of pin, $V_{CC1} = 0\ \text{V}$ <sup>2)</sup>	P_6.3.21

**Voltage Regulator 1**

**Table 12 Electrical Characteristics** (cont'd)

$V_{SINT} = 5.5 \text{ V to } 28 \text{ V}$ ;  $T_j = -40^\circ\text{C to } +175^\circ\text{C}$ ; all voltages with respect to ground, positive current flowing into pin (unless otherwise specified).

Parameter	Symbol	Values			Unit	Note or Test Condition	Number
		Min.	Typ.	Max.			
Minimum Output Capacitance for stability	$C_{VCC1,min}$	1 <sup>3)</sup>	–	–	$\mu\text{F}$	2)	P_6.3.22
Maximum Output Capacitance	$C_{VCC1,max}$	–	–	47	$\mu\text{F}$	2)	P_6.3.23

- 1) In Stop Mode, the specified output voltage tolerance applies when  $I_{VCC1}$  has exceeded the selected active peak threshold ( $I_{VCC1,peak1,r}$  or  $I_{VCC1,peak2,r}$ ) but with increased current consumption.
- 2) Not subject to production test, specified by design.
- 3) Value is meant to be an effective value at rated output voltage level.

## 7 High-Voltage Wake Input

The WK4 pin is used to wake up the device.

### 7.1 Block Description

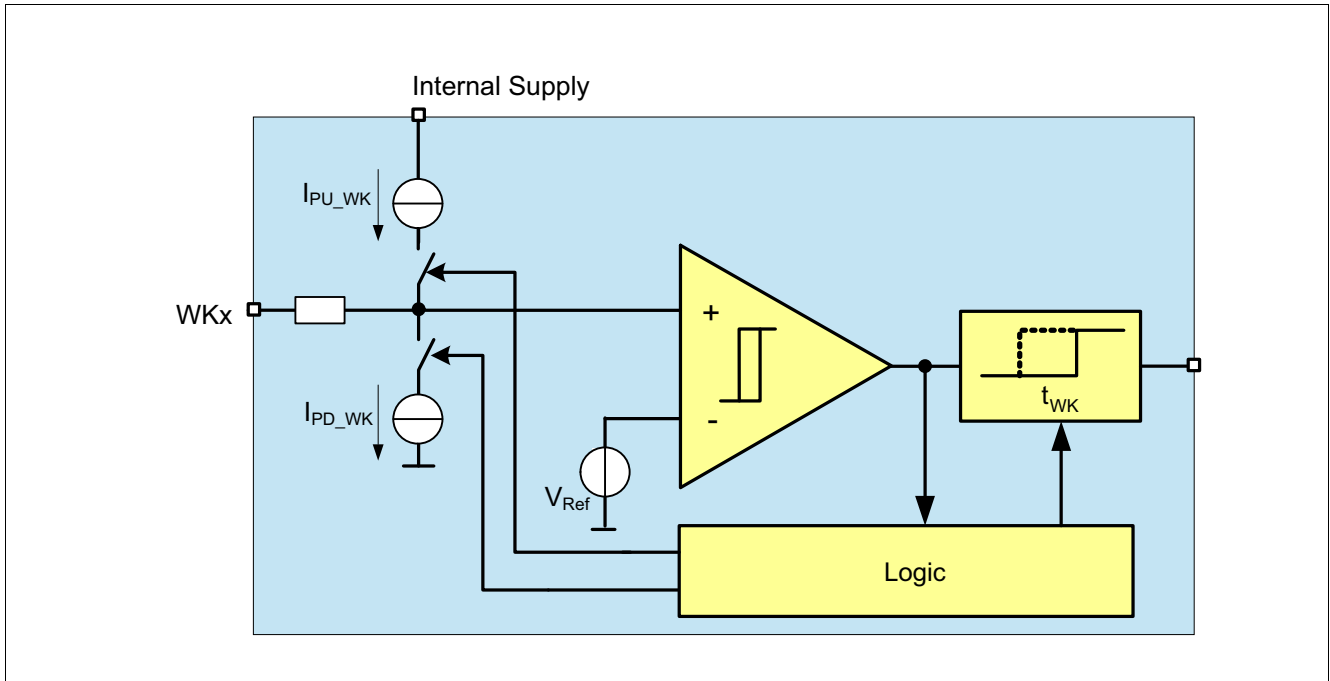

Figure 17 Wake Input Block Diagram

#### Features

- High-Voltage inputs with a 3 V (typ.) threshold voltage.
- Wake-up capability for power saving modes.
- Edge sensitive wake feature low to high and high to low.
- Pull-up and Pull-down current sources, configurable via SPI.
- In Normal Mode and Stop Mode the level of the WKx pin can be read via SPI.

## High-Voltage Wake Input

### 7.2 High-Voltage Wake Function

#### 7.2.1 Functional Description

The wake inputs pin are edge-sensitive inputs with a switching threshold of typically 3 V. Both transitions, high to low and low to high, result in a signalization by the device. The signalization occurs either in triggering the interrupt in Normal Mode and Stop Mode or by a wake up of the device in Sleep Mode and Fail-Safe Mode.

A filter time  $t_{FWKx}$  is implemented to avoid an unintentional wake-up due to transients or EMC disturbances in static sense configuration.

The filter time ( $t_{FWKx}$ ) is triggered by a level change crossing the switching threshold and a wake signal is recognized if the input level will not cross again the threshold during the selected filter time.

**Figure 18** shows a typical wake-up timing and filtering of transient pulses.

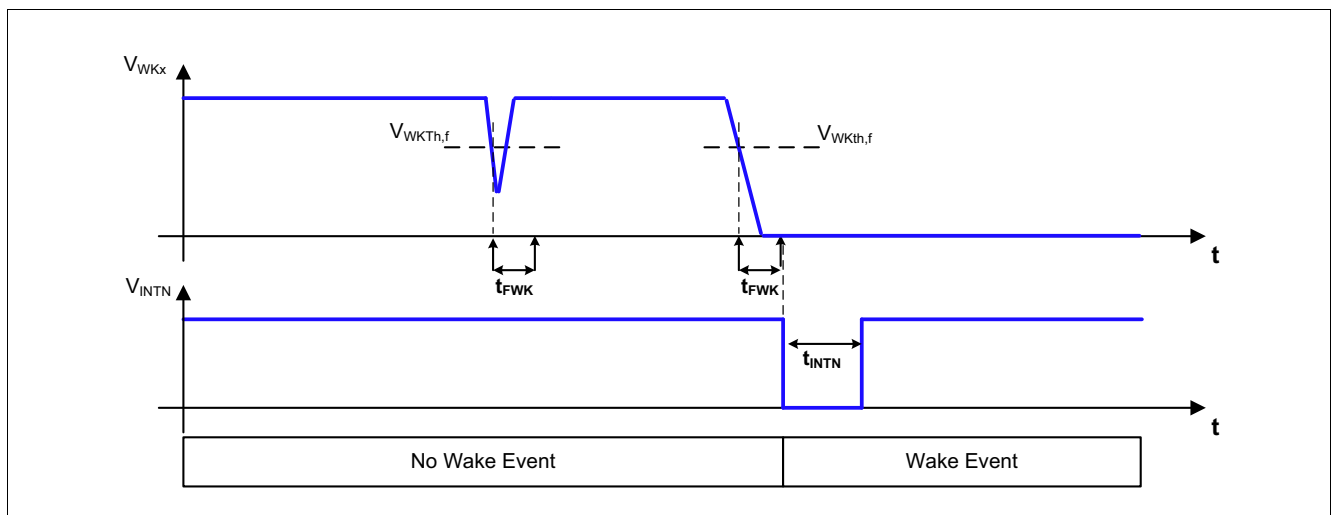

**Figure 18** Wake-up Filter Timing for Static Sense

The wake-up capability for the WKx pin can be enabled or disabled via SPI command.

A wake event via the WKx pin can always be read in the register **WK\_STAT**.

The actual voltage level of the WKx pin (low or high) can always be read in Normal Mode, Stop Mode and Init Mode in the register **WK\_LVL\_STAT**.

#### 7.2.2 Wake Input Configuration

To ensure a defined and stable voltage levels at the internal comparator input it is possible to configure integrated current sources via the SPI register **WK\_CTRL**.

**Table 13** Pull-Up / Pull-Down Resistor

WKx_PUPD_1	WKx_PUPD_0	Current Sources	Note
0	0	no current source	WK input is floating if left open (default setting)
0	1	pull-down	WK input internally pulled to GND

**High-Voltage Wake Input**

**Table 13 Pull-Up / Pull-Down Resistor (cont'd)**

WKx_PUPD_ <b>1</b>	WKx_PUPD_ <b>0</b>	Current Sources	Note
1	0	pull-up	WK input internally pulled to internal 5V supply
1	1	Automatic switching	If a high level is detected at the WK input the pull-up source is activated, if low level is detected the pull down is activated.

*Note: If a WK input is not used, the respective WK input must be tied to GND on board to avoid unintended floating state of the pin.*

One additional configuration is related the filter time of each Wake-up module. The bits **WK\_FILT** permit to set the filter time in static sensing.

*Note: When the device mode is changed to normal (from INIT), in case of static sense, if the WK pin is set, the WK\_STAT register is set in this time (also the interrupt pin).*

## High-Voltage Wake Input

### 7.3 Electrical Characteristics

**Table 14 Electrical Characteristics**

$V_{SINT} = 5.5\text{ V to }28\text{ V}$ ;  $T_j = -40^\circ\text{C to }+175^\circ\text{C}$ ; all voltages with respect to ground, positive current flowing into pin (unless otherwise specified)

Parameter	Symbol	Values			Unit	Note or Test Condition	Number
		Min.	Typ.	Max.			
<b>WK4 Input Pin Characteristics</b>							
Wake-up/monitoring threshold voltage falling	$V_{WKx\_th,f}$	2.5	3	3.5	V	without external serial resistor $R_S$	P_10.3.1
Wake-up/monitoring threshold voltage rising	$V_{WKx\_th,r}$	3	3.5	4	V	without external serial resistor $R_S$	P_10.3.2
Threshold hysteresis	$V_{WKx\_th,hys}$	0.4	0.6	0.85	V	without external serial resistor $R_S$	P_10.3.3
WK pin Pull-up Current	$I_{PU\_WKx}$	-20	-10	-3	$\mu\text{A}$	$V_{WKx} = 4\text{ V}$	P_10.3.4
WK pin Pull-down Current	$I_{PD\_WKx}$	3	10	20	$\mu\text{A}$	$V_{WKx} = 2.5\text{ V}$	P_10.3.5
Input leakage current	$I_{LK,lx}$	-2	-	2	$\mu\text{A}$	$0\text{ V} < V_{WKx} < V_{SINT}$ ; Pull-up / Pull-down disabled	P_10.3.6
Input leakage current	$I_{LK,lx}$	-2	-	40	$\mu\text{A}$	<sup>1)</sup> $0\text{ V} < V_{SINT} < V_{WKx} < 40\text{ V}$ ; Pull-up / Pull-down disabled	P_10.3.106

#### Timing

Wake-up filter time 1	$t_{FWK1}$	12	16	22	$\mu\text{s}$	<sup>2)</sup>	P_10.3.16
Wake-up filter time 2	$t_{FWK2}$	50	64	80	$\mu\text{s}$	<sup>2)</sup>	P_10.3.17

1) Not subject to production test - specified by design.

2) Not subject to production test, tolerance defined by internal oscillator tolerance.

## 8 Interrupt Function

### 8.1 Block and Functional Description

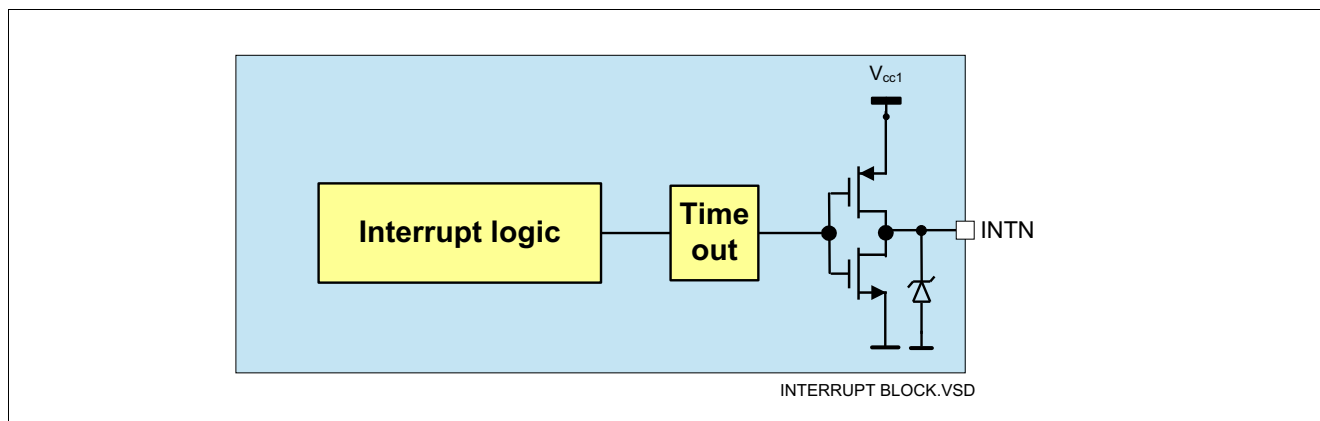

**Figure 19** Interrupt Block Diagram

The interrupt is used to signalize special events in real time to the microcontroller. The interrupt block is designed as a push/pull output stage as shown in [Figure 19](#). An interrupt is triggered and the INTN pin is pulled low (active low) for  $t_{INTN}$  in Normal Mode and Stop Mode and it is released again once  $t_{INTN}$  is expired. The minimum high-time of INTN between two consecutive interrupts is  $t_{INTND}$ . An interrupt does not cause a device mode change.

Two different interrupt generation methods are implemented:

- Interrupt Mask: One dedicated register (INT\_MASK) is intended to enable or disable set of interrupt sources. The interrupt sources follow the SPI Status Information Field.  
In details:
  - SUPPLY\_STAT: “OR” of all bits on SUP\_STAT register except POR, VCC1\_UV, VCC1\_SC, VCC1\_OV
  - TEMP\_STAT: “OR” of all bits on THERM\_STAT register except TSD2
  - BD\_STAT: “OR” of all bits on DSOV register
  - SPI\_CRC\_FAIL: or between SPI\_FAIL and CRC\_FAIL bits on DEV\_STAT register.
- Wake-up events: all wake-up events stored in the wake status SPI register WK\_STAT only in case the corresponding input was configured as wake-up source.  
The wake-up sources are:
  - via WK pin
  - via TIMERx (cyclic wake)
  - via LSx\_DSOV\_BRK if any of the brake-feature is enabled

The methods are both available at the same time.

*Note:* The errors which will cause Restart or Fail-Safe Mode (VCC1\_UV, VCC1\_SC, VCC1\_OV, TSD2) are the exceptions of an INTN generation. Also the bit POR will not generate interrupts. If the above mentioned bits are not cleared after the device is back in Normal Mode or Stop Mode, the INTN is periodically generated (Register based cyclic interrupt generation).

*Note:* Periodical interrupts are only generated by CRC fail and SPI fail from DEV\_STAT register.



**Interrupt Function**

*Note:* During Restart Mode the SPI is blocked and the microcontroller is in reset. Therefore the INTN will not be in Restart Mode, which is the same behavior in Fail-Safe Mode or Sleep Mode.

In addition to this behavior, INTN will be triggered when Stop Mode is entered and not all wake source bits were cleared in the WK\_STAT register and also the LSx\_DSOV\_BRK bits in the DSOV register..

The SPI status registers are updated at every falling edge of the INTN pulse. All interrupt events are stored in the respective register until the register is cleared via SPI command. A second SPI read after reading out the respective status register is optional but recommended to verify that the interrupt event is not present anymore. The interrupt behavior is shown in **Figure 20**.

The INTN pin is also used during Init Mode to select the Software Development Mode entry. See **Chapter 5.2** for further information.

In case of pending INTN event (SPI Status registers are not cleared after INTN event), additional periodical INTN events are generated as shown in **Figure 21**.

The periodical INTN events generation can be disabled via SPI command using **INTN\_CYC\_EN** bit.

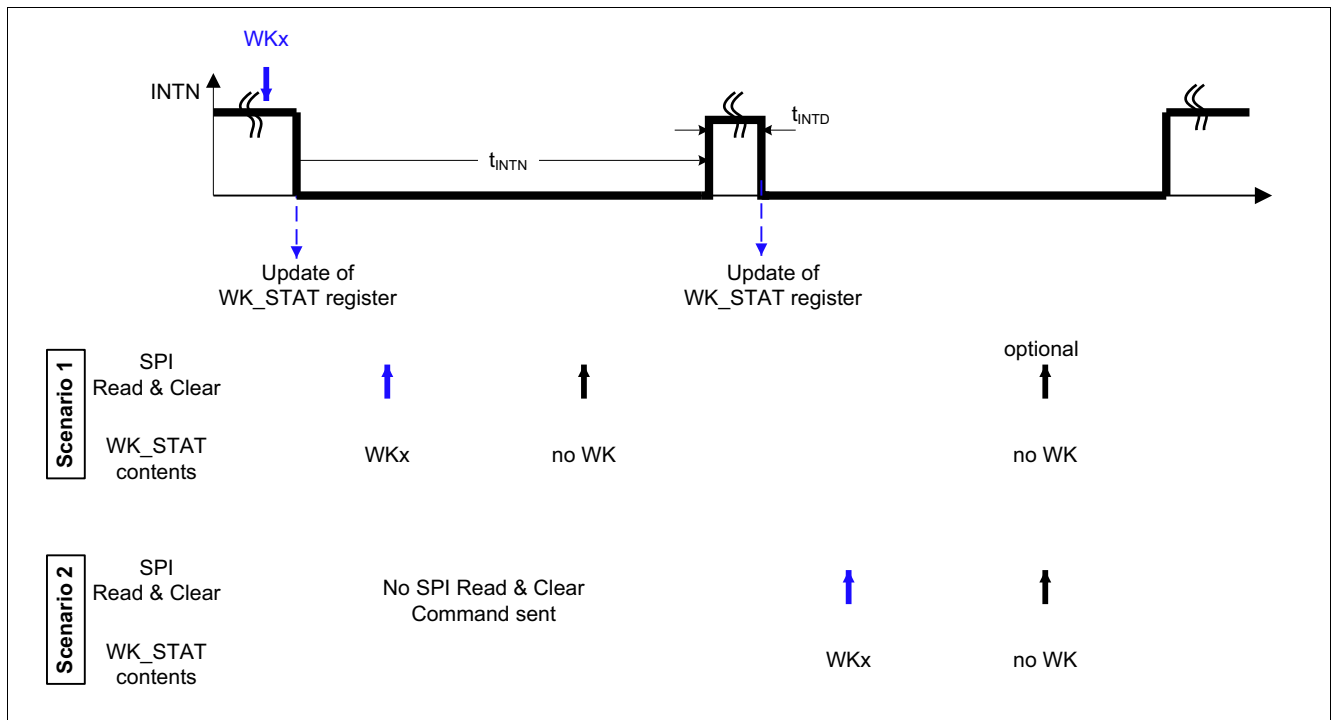

**Figure 20** Interrupt Signaling Behavior

*Note:* For two or more interrupt events at the same time, when INTN pin is low the same time, it will not start multiple toggling.

Interrupt Function

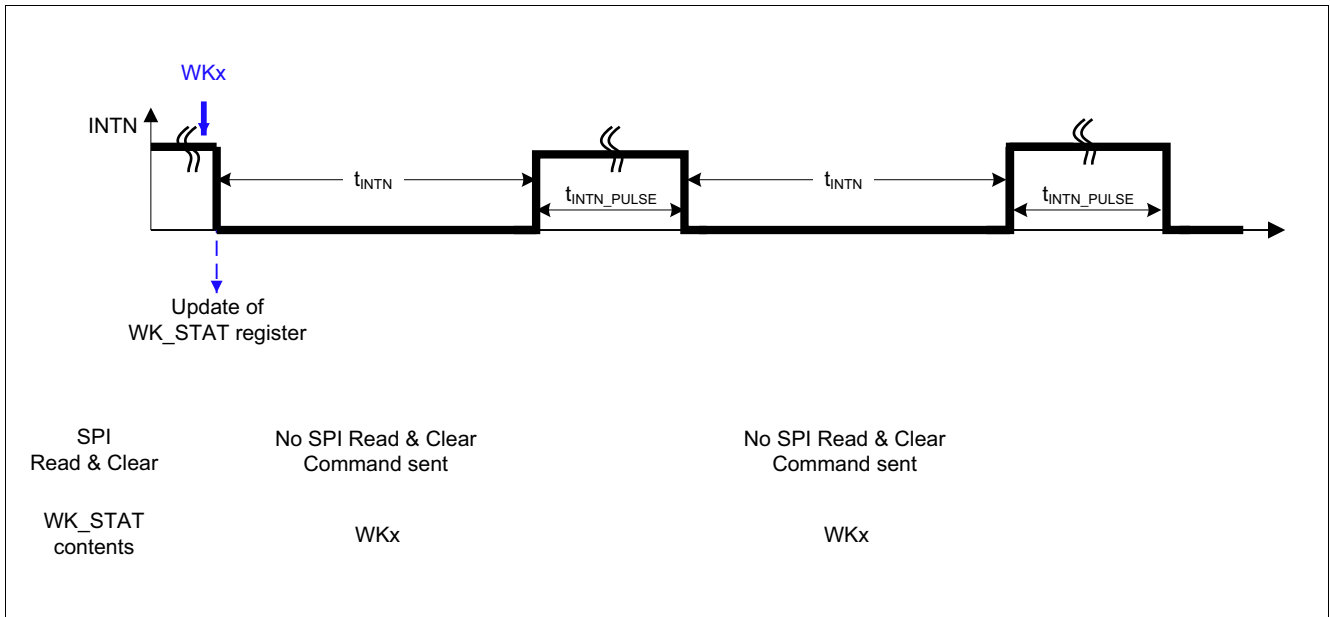

Figure 21 Interrupt Signalization Behavior in case of pending INTN events

**Interrupt Function**

**8.2 Electrical Characteristics**

**Table 15 Electrical Characteristics**

$V_{SINT} = 5.5\text{ V to }28\text{ V}$ ;  $T_j = -40^\circ\text{C to }+175^\circ\text{C}$ ; Normal Mode; all voltages with respect to ground; positive current defined flowing into pin; unless otherwise specified.

Parameter	Symbol	Values			Unit	Note or Test Condition	Number
		Min.	Typ.	Max.			
<b>Interrupt Output; Pin INTN</b>							
INTN High Output Voltage	$V_{INTN,H}$	$0.8 \times V_{CC1}$	–	–	V	<sup>1)</sup> $I_{INTN} = -2\text{ mA}$ ; INTN = off	P_11.2.1
INTN Low Output Voltage	$V_{INTN,L}$	–	–	$0.2 \times V_{CC1}$	V	<sup>1)</sup> $I_{INTN} = 2\text{ mA}$ ; INTN = on	P_11.2.2
INTN Pulse Width	$t_{INTN}$	80	100	120	$\mu\text{s}$	<sup>2)</sup>	P_11.2.3
INTN Pulse Minimum Delay Time	$t_{INTND}$	80	100	120	$\mu\text{s}$	<sup>2)</sup> between consecutive pulses	P_11.2.4
Pulse in case of pending INTN	$t_{INTN\_PULSE}$	4	5	6	ms	<sup>2)</sup> between consecutive pulses	P_11.2.5
<b>SDM Select; Pin INTN</b>							
Config Pull-up Resistance	$R_{SDM}$	30	60	100	k $\Omega$	$V_{INTN} = 5\text{ V}$	P_11.2.6
Config Select Filter Time	$t_{SDM\_F}$	50	64	80	$\mu\text{s}$	<sup>2)</sup>	P_11.2.7

1) Output Voltage Value also determines device configuration during Init Mode.

2) Not subject to production test, tolerance defined by internal oscillator tolerance.

## 9 Gate Drivers

The TLE9185QXW integrates six floating gate drivers capable of controlling a wide range of N-channel MOSFETs. They are configured as three high-sides and three low-sides, building three half-bridges.

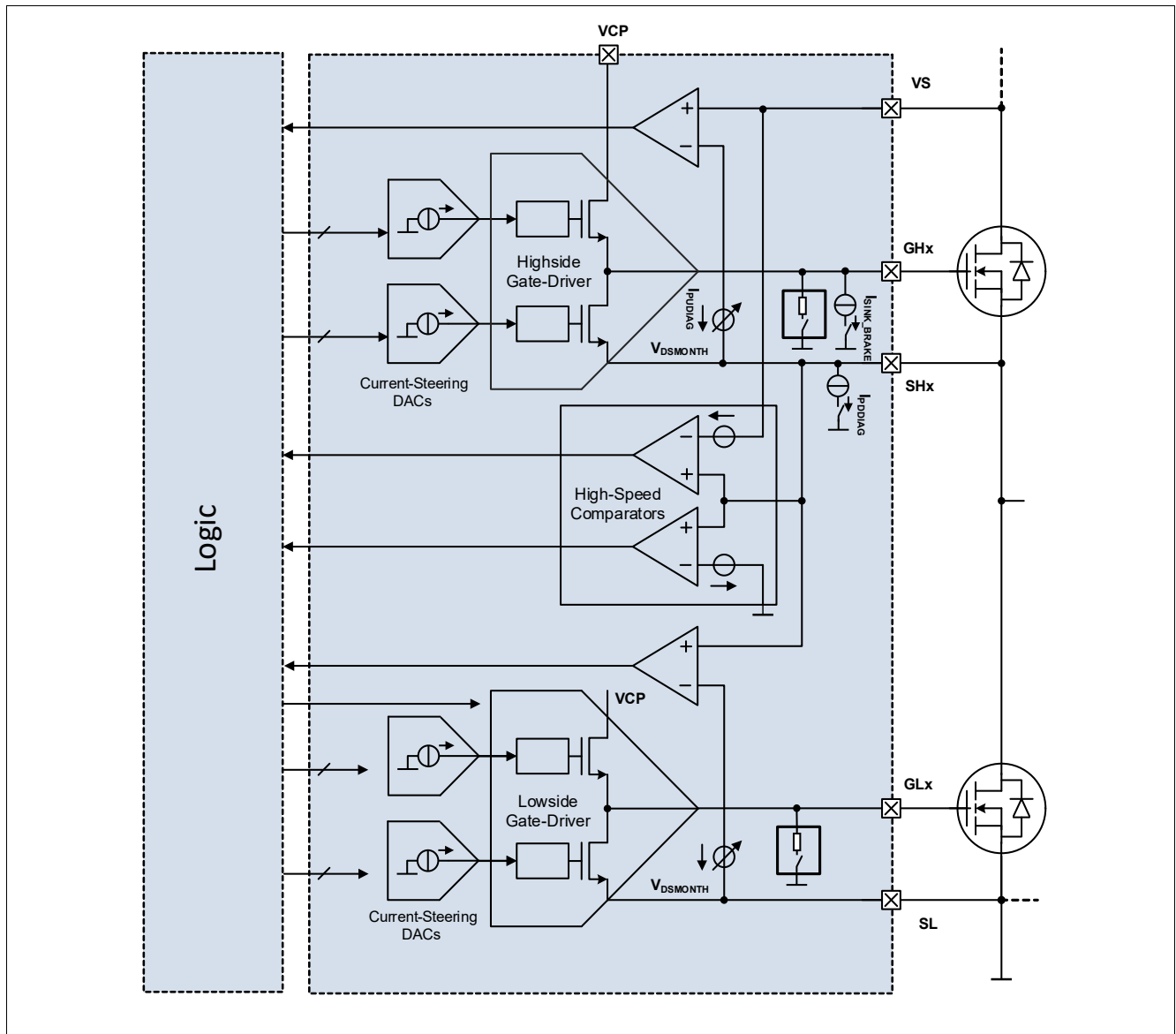

**Figure 22 Half-bridge gate driver - Block diagram**

This section describes the MOSFET control in static activation and during PWM operation.

*Note:* PWMx mentioned in this chapter refer to the PWMx pins and signal used by the bridge driver to control the external MOSFETs.

### 9.1 MOSFET control

Depending on the configuration bits HBxMODE[1:0] (refer to **HBMODE**), **CPEN**, each high-side and low-side MOSFETs can be:

- Kept off with the passive discharge.
- Kept off actively.

**Gate Drivers**

- Activated (statically, no PWM, HBx\_PWM\_EN = 0).
- Activated in PWM mode (HBx\_PWM\_EN = 1).

Refer to **Table 16** for details.

**Table 16 Half-bridge mode selection**

CPEN	HBxMODE[1:0] <sup>1)</sup>	Configuration of HSx/LSx <sup>1)</sup>
CPEN = 0	Don't care	All MOSFETs are kept off by the passive discharge
CPEN = 1	00 <sub>B</sub>	HBx MOSFETs are kept off by the passive discharge
CPEN = 1	01 <sub>B</sub>	LSx MOSFET is ON, HSx MOSFET is actively kept OFF
CPEN = 1	10 <sub>B</sub>	HSx MOSFET is ON, LSx MOSFET is actively kept OFF
CPEN = 1	11 <sub>B</sub>	LSx and HSx MOSFETs are actively kept OFF with IHOLD

1) x = 1 ... 3

**9.2 Static activation**

In this section, we consider the static activation of the high-side and low-side MOSFET of the half-bridge x: HBx\_PWM\_EN= 0 (in **ST\_ICHG**) and **CPEN** = 1.

The low-side or high-side MOSFET of HBx is statically activated (no PWM) by setting HBxMODE[1:0] to respectively (0,1) or (1,0).

The configured active cross-current protection and the Drain-Source overvoltage blank times for the Half-Bridge x are noted  $t_{HBxCCP\ ACTIVE}$  and  $t_{HBxBLANK\ ACTIVE}$ .

The charge and discharge currents applied to the static controlled Half-Bridge x are noted ICHGSTx (**ST\_ICHG**).

IHARDOFF is the maximum current that the gate drivers can sink (150 mA typ.). This current is used to keep a MOSFET off, when the opposite MOSFET of the same half-bridge is being turned on. This feature reduces the risk of parasitic cross-current conduction.

ICHGSTx is the current sourced, respectively sunk, by the gate driver to turn-on the high-side x or low-side x. ICHGSTx is configured in the control register **ST\_ICHG**.

**Table 17 Static charge currents**

ICHGSTx[3:0]	Nom. charge current [mA]	Nom. discharge current [mA]	Max. deviation to typ. values
0000 <sub>B</sub>	0.5 ( $I_{CHG0}$ )	0.5 ( $I_{DCHG0}$ )	+/- 60%
0001 <sub>B</sub>	1.8 ( $I_{CHG4}$ )	1.8 ( $I_{DCHG4}$ )	+/- 60 %
0010 <sub>B</sub>	4.7 ( $I_{CHG8}$ )	4.7 ( $I_{DCHG8}$ )	+/- 60 %
0011 <sub>B</sub>	9.4 ( $I_{CHG12}$ )	9.4 ( $I_{DCHG12}$ )	+/- 60 %
0100 <sub>B</sub>	15.3 ( $I_{CHG16}$ )	15.1 ( $I_{DCHG16}$ )	+/- 40 %
0101 <sub>B</sub>	23 ( $I_{CHG20}$ )	22.5 ( $I_{DCHG20}$ )	+/- 40 %
0110 <sub>B</sub>	31.6 ( $I_{CHG24}$ )	30.9 ( $I_{DCHG24}$ )	+/- 40 %
0111 <sub>B</sub>	41.6 ( $I_{CHG28}$ )	40.8 ( $I_{DCHG28}$ )	+/- 40%

**Gate Drivers**

**Table 17 Static charge currents (cont'd)**

<b>ICHGSTx[3:0]</b>	<b>Nom. charge current [mA]</b>	<b>Nom. discharge current [mA]</b>	<b>Max. deviation to typ. values</b>
1000 <sub>B</sub>	52.5 ( $I_{CHG32}$ )	51.5 ( $I_{DCHG32}$ )	+/- 30 %
1001 <sub>B</sub>	63.6 ( $I_{CHG36}$ )	62.4 ( $I_{DCHG36}$ )	+/- 30 %
1010 <sub>B</sub>	75.2 ( $I_{CHG40}$ )	73.7 ( $I_{DCHG40}$ )	+/- 30 %
1011 <sub>B</sub>	87.1 ( $I_{CHG44}$ )	85.5 ( $I_{DCHG44}$ )	+/- 30 %
1100 <sub>B</sub>	99.5 ( $I_{CHG48}$ )	97.7 ( $I_{DCHG48}$ )	+/- 30 %
1101 <sub>B</sub>	112.2 ( $I_{CHG52}$ )	110.8 ( $I_{DCHG52}$ )	+/- 30 %
1110 <sub>B</sub>	125.3 ( $I_{CHG56}$ )	124.5 ( $I_{DCHG56}$ )	+/- 30 %
1111 <sub>B</sub>	139 ( $I_{CHG60}$ )	138.7 ( $I_{DCHG60}$ )	+/- 30 %

IHOLD is the hold current used to keep the gate of the external MOSFETs in the desired state. This parameter is configurable with the IHOLD control bit in **GENCTRL**.

If the control bit IHOLD = 0:

- A MOSFET is kept ON with the current  $I_{CHG15}$ .
- A MOSFET is kept OFF with the current  $I_{DCHG15}$ .

If the control bit IHOLD = 1:

- A MOSFET is kept ON with the current  $I_{CHG20}$ .
- A MOSFET is kept OFF with the current  $I_{DCHG20}$ .

### 9.2.1 Static activation of a high-side MOSFET

#### Turn-on with cross-current protection

If LSx is ON (HBxMODE[1:0] = 01<sub>B</sub>), before the activation of HSx (HBxMODE[1:0] = 10<sub>B</sub>) then the high-side MOSFET is turned on after a cross-current protection time (refer to **Figure 23**):

- After the CSN rising edge and for the duration  $t_{HBxCCP\ ACTIVE}$ :
  - The high-side MOSFET is kept OFF with the current -ICHGSTx.
  - The gate of the low-side MOSFET is discharged with the current -ICHGSTx.
- At the end of  $t_{HBxCCP\ ACTIVE}$  and for the duration  $t_{HBxBLANK\ ACTIVE} + t_{FVDS}$ :
  - The gate of the high-side MOSFET is charged with the current ICHGSTx.
  - Low-side MOSFET is kept OFF with the current -IHARDOFF (hard off phase).
- At the end of  $t_{FVDS}$ :
  - The drive current of the high-side MOSFET is reduced to IHOLD.
  - The drive current of the low-side MOSFET is set to -IHOLD.

Gate Drivers

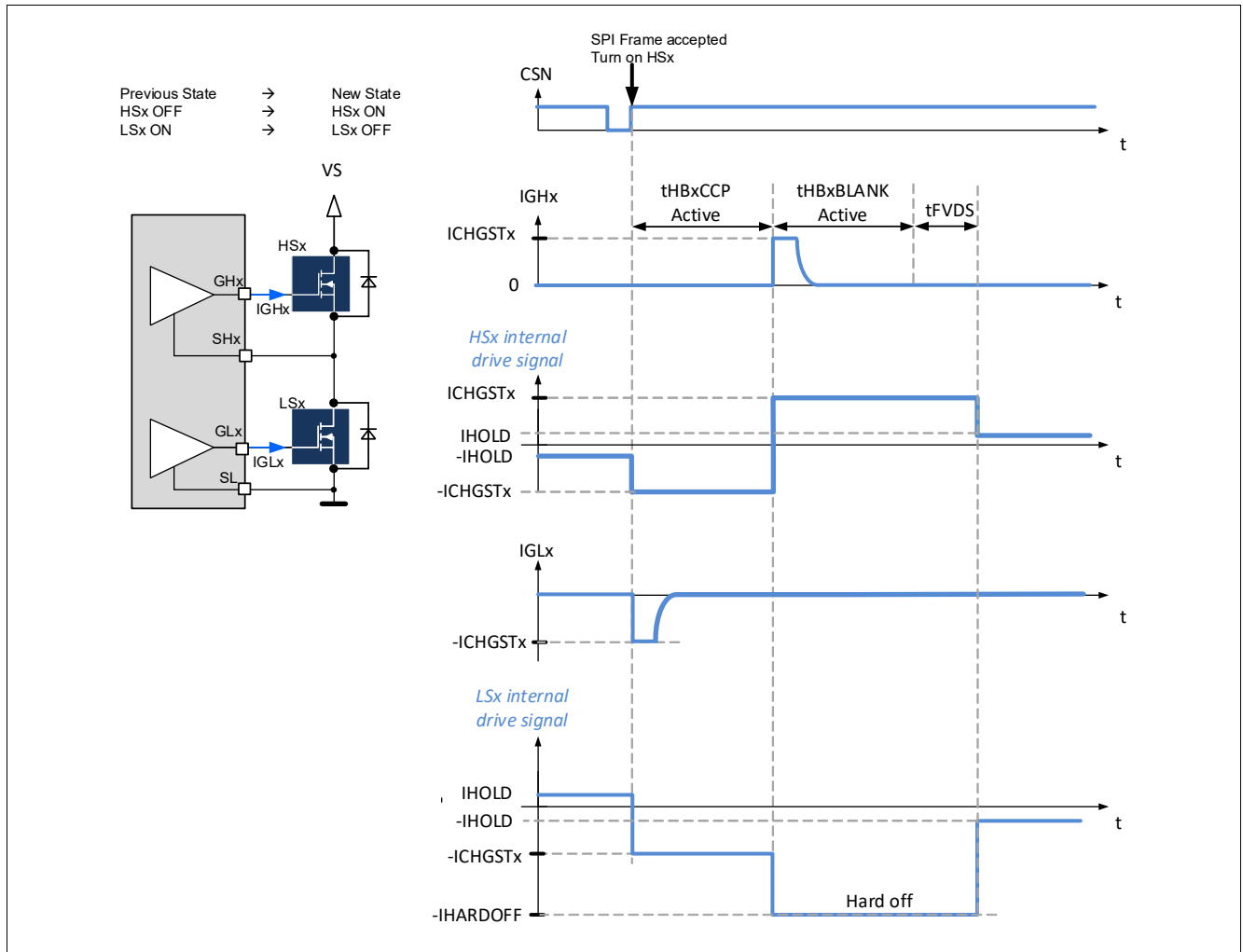

**Figure 23 Turn-on of a high-side MOSFET with cross-current protection**

*Note:* The CSN rising edge must be synchronized with the device logic. Therefore SPI commands are executed with a delay of up to 3 μs after the CSN rising edge.

Gate Drivers

**Turn-on without cross-current protection**

If LSx is OFF ( $HBxMODE[1:0] = 11_B$ ), before the activation of HSx ( $HBxMODE[1:0] = 10_B$ ), then the high-side MOSFET is turned on without cross-current protection (refer to **Figure 24**):

- right after the CSN rising edge and for a duration  $t_{HBxBLANKACTIVE} + t_{FVDS}$ :
  - The gate of the high-side MOSFET is charged with the current  $ICHGSTx$ .
  - The low-side MOSFET is kept OFF with the current  $-IHARDOFF$ .
- At the end of  $t_{FVDS}$ :
  - The drive current of the high-side MOSFET is reduced to  $IHOLD$ .
  - The drive current of the low-side MOSFET is set to  $-IHOLD$ .

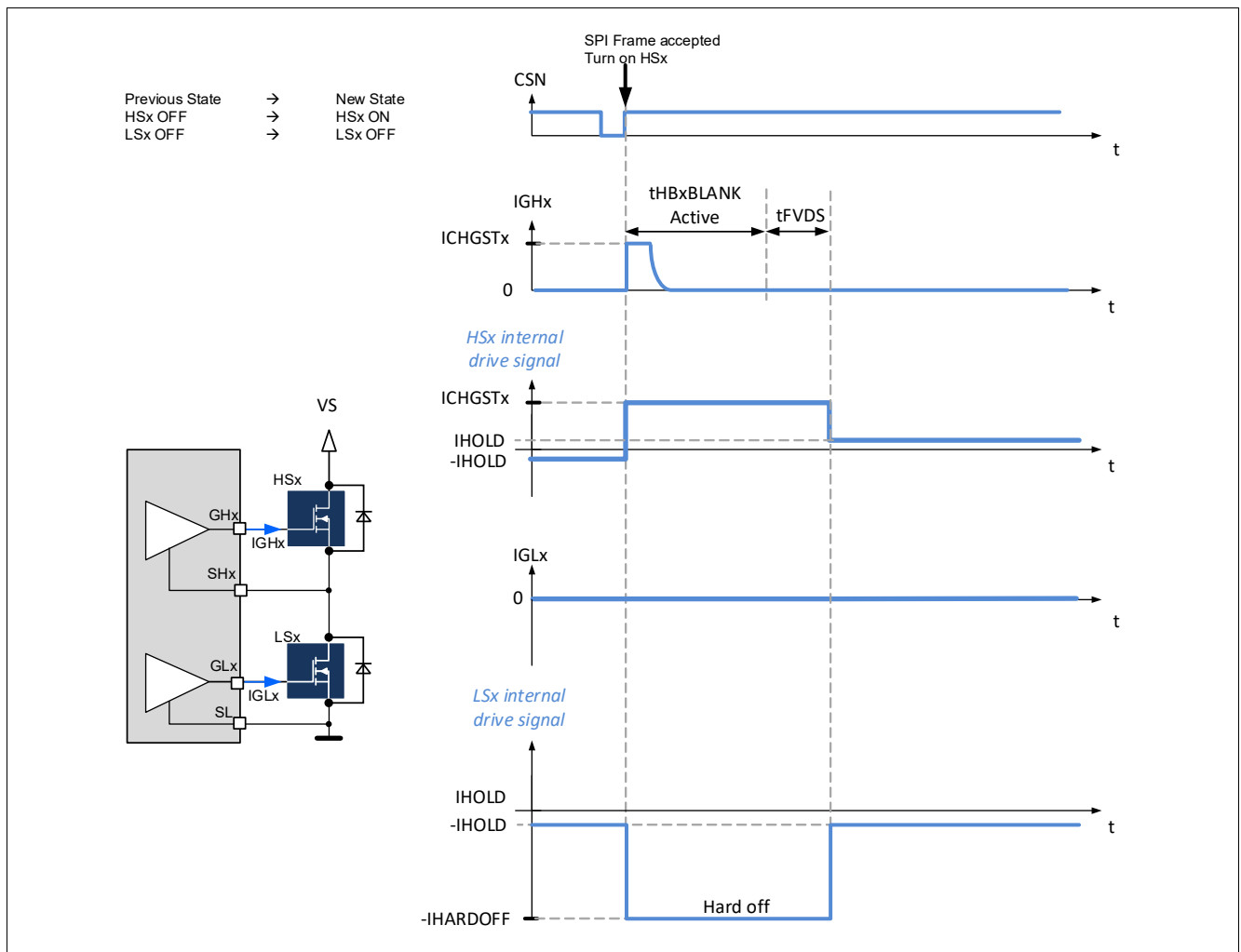

**Figure 24 Turn-on of a high-side MOSFET without cross-current protection**

*Note: The CSN rising edge must be synchronized with the device logic. Therefore SPI commands are executed with a delay of up to 3  $\mu$ s after the CSN rising edge.*



### 9.2.2 Static activation of a low-side MOSFET

The description of the static activation of a low-side x differs from the description of [Chapter 9.2.1](#) only by exchanging high-side x and low-side x.

### 9.2.3 Turn-off of the high-side and low-side MOSFETs of a half-bridge

When the TLE9185QXW receives a SPI command to turn-off both the high-side and low-side MOSFETs of the half-bridge x ( $HBxMODE[1:0] = (0,0)$  or  $(1,1)$ ):

- The gate of HSx and LSx are discharged with the current  $-ICHGSTx$  for the duration  $t_{HBxCCP ACTIVE}$  ([Figure 25](#)).
- At the end of  $t_{HBxCCP ACTIVE}$ , the drive current of HSx and LSx are reduced to  $-IHOLD$ .

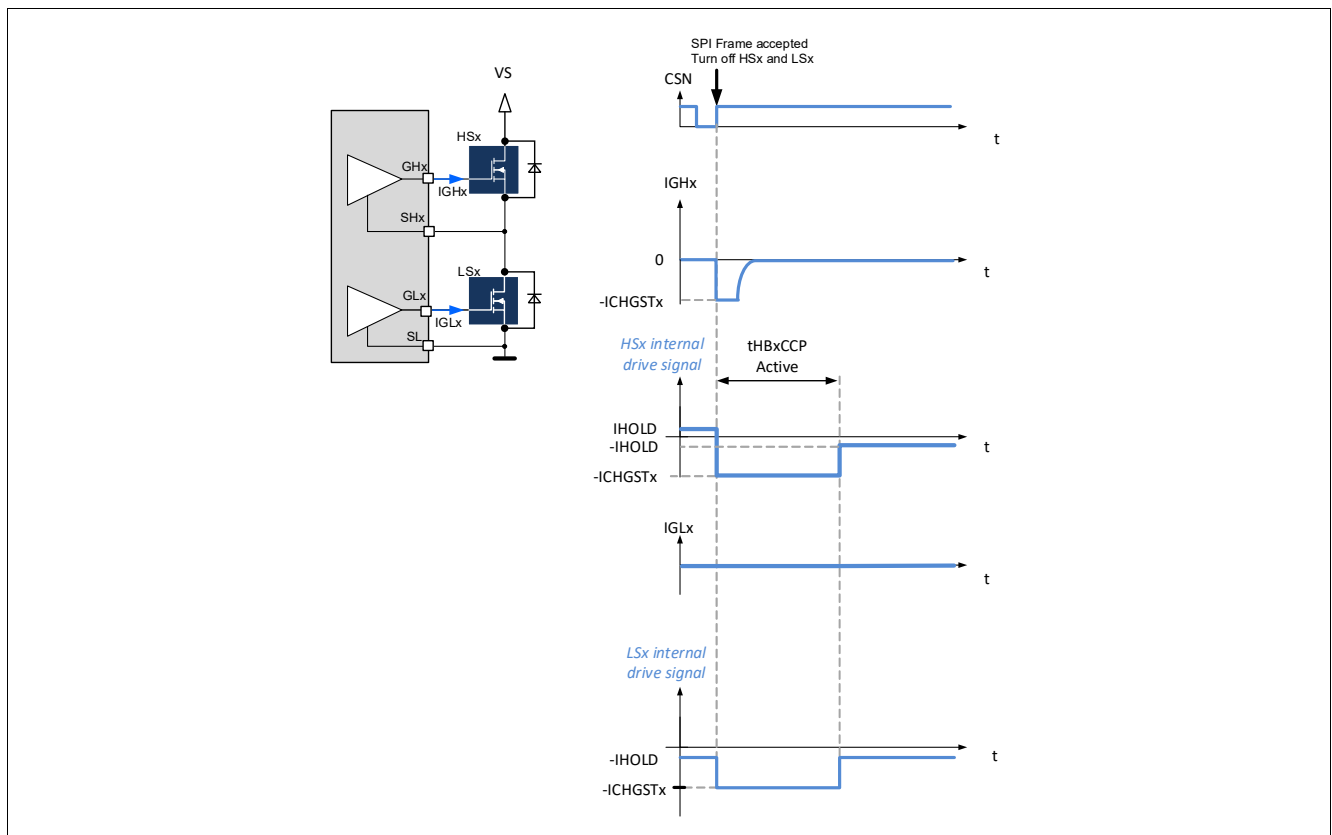

**Figure 25** Turn-off of the high-side and low-side MOSFETs of a half-bridge

*Note:* The CSN rising edge must be synchronized with the device logic. Therefore SPI commands are executed with a delay of up to  $3 \mu s$  after the CSN rising edge.

### 9.3 PWM operation

The half-bridge can be controlled in PWM using either three or six PWM inputs.

The TLE9185QXW offers the possibility to detect the active and the freewheeling (FW) MOSFET in each half-bridge.

#### 9.3.1 Determination of the active and freewheeling MOSFET

If  $EN\_GEN\_CHECK = 1$ , right before each MOSFET activation, the device detects which MOSFET of the half-bridge is the active MOSFET and which MOSFET is the free-wheeling (FW) MOSFET:

- If  $VSHx > VS - VSHH$ : The high-side MOSFET is the FW MOSFET and the low-side MOSFET is the active MOSFET.
- If  $VSHx < VSHL$ : Then the low-side MOSFET is the FW MOSFET and the high-side MOSFET is the active MOSFET.
- If  $VSHL < VSHx < VSHH$ : No clear distinction between the active FW MOSFET and the active MOSFET. The next MOSFET to be turned on is turned on as if it was the active MOSFET.

If  $EN\_GEN\_CHECK = 0$ , the detection of the active and FW MOSFET is disabled. The PWM MOSFET is considered as the active MOSFET.

Figure 26 shows the detection of the active and of the FW MOSFET.

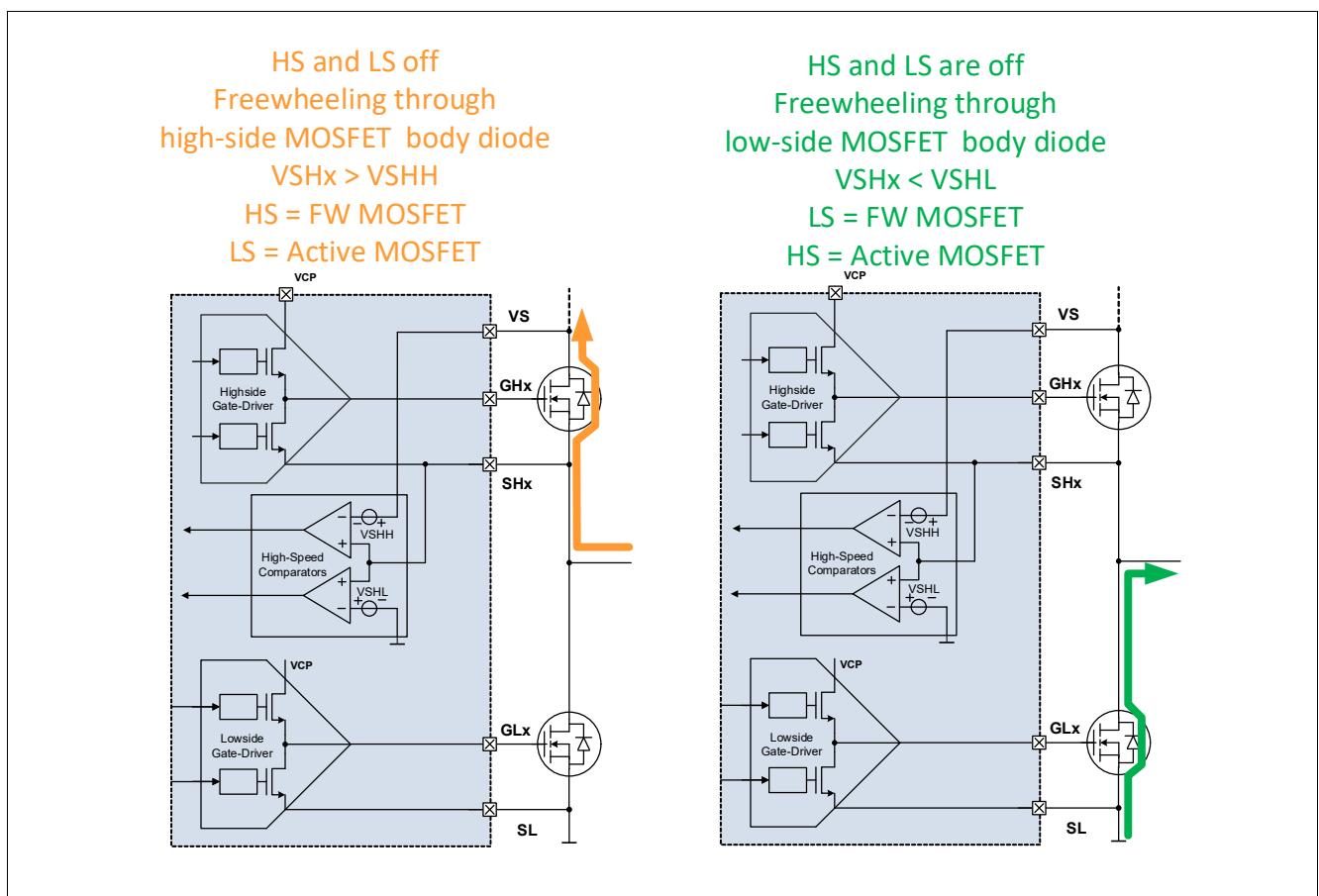

Figure 26 Detection of the active and FW MOSFET - Principle

#### 9.3.2 Configurations in PWM mode

The following sections describe the different control schemes in PWM mode.

## Gate Drivers

### Active gate control (AGC)

The active gate control is configured by the control bits AGC[1:0]. The control scheme during the pre-charge and pre-discharge phases of:

- The active MOSFET (**EN\_GEN\_CHECK**=1).
- The PWM MOSFET (**EN\_GEN\_CHECK**=0).

can be selected.

The following settings are possible:

- Adaptive gate control (AGC[1:0] = (1,0) or (1,1), see **GENCTRL**): In this mode a pre-charge current and a pre-discharge current are applied to the gate of the controlled MOSFET. These currents are used to regulate effectively the turn-on and turn-off delays to the respective target values.
- No adaptive gate control (AGC[1:0] = (0,0)): in this mode, the pre-charge and pre-discharge phases are deactivated.
- No adaptive gate control (AGC[1:0] = (0,1)). In this mode:
  - During the pre-charge phase, the MOSFET is discharged with the configured current IPCHGINIT (**HB\_PCHG\_INIT**).
  - During the pre-discharge phase, the MOSFET is discharged with the configured current IPDCHGINIT (**HB\_PCHG\_INIT**).

*Note: It is recommended to configure  $tPCHG_x < tHBxBLANK$  Active and  $tPDCHG_x < tHBxCCP$  Active (Refer to **TPRECHG** and **CCP\_BLK**) independently from the AGC settings.*

### Active free-wheeling (AFW)

The active free-wheeling is activated for HBx if these conditions are fulfilled:

- AFWx = 1 (**HBMODE**)
- HBx\_PWM\_EN = 1 (**HBMODE**)
- **PWM\_NB** = 0

If AFWx = 1, a cross-current protection time is applied to HBx (set by **CCP\_BLK**) during the PWM operation.

If AFWx = 0, no cross current protection is applied to HBx during the PWM operation.

The active free-wheeling reduces the power dissipation of the free-wheeling MOSFET. If an active MOSFET is OFF, the opposite MOSFET of the same half-bridge is actively turned on. Refer to **Figure 30** and **Figure 31**.

Gate Drivers

Post-charge

A post-charge is initiated if POCHGDIS is set to 0 (**GENCTRL**) to reach the minimum MOSFET  $R_{dson}$ :

- **POCHGDIS** = 0: After the charge phase, the control signal for the charge current of LSx is increased by one current step at every bridge driver clock cycle (**BDFREQ**) to ICHGMAXx. Refer to **Figure 27**
- **POCHGDIS** = 1: The post-charge phase is disabled. The charge current is kept to the ICHGx

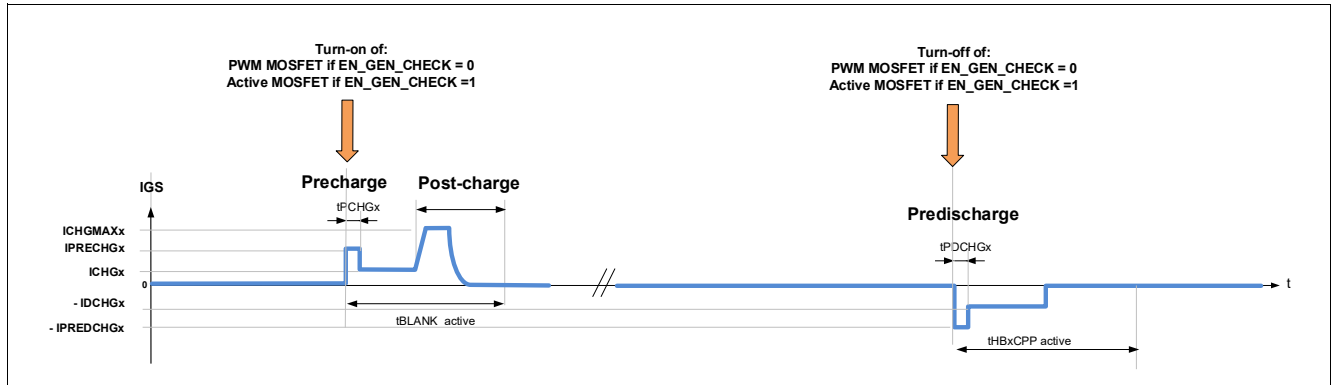

Figure 27 PWM overview - AGC = 10<sub>B</sub> or 11<sub>B</sub>, POCHGDIS=0 (post-charge enabled)

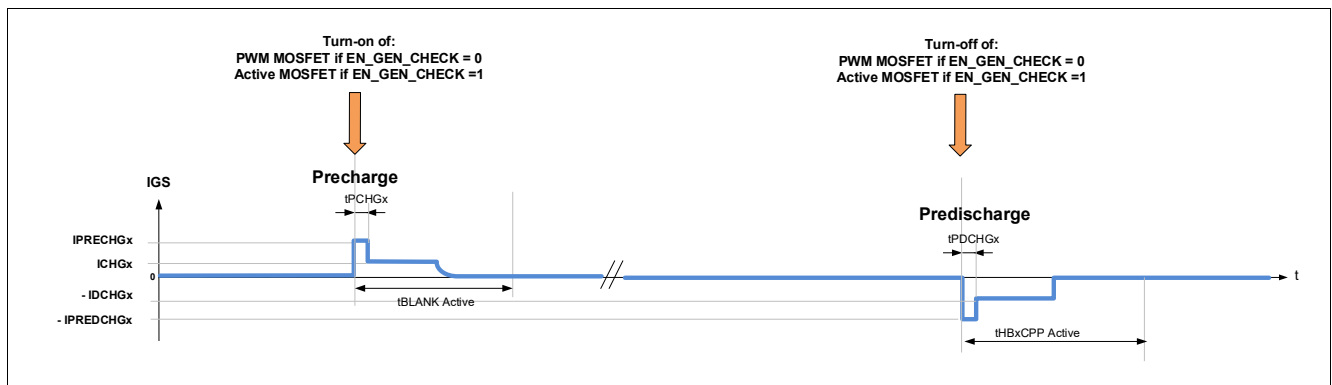

Figure 28 PWM overview - AGC = 10<sub>B</sub> or 11<sub>B</sub>, POCHGDIS=1 (post-charge disabled)

Table 18 Abbreviations for adaptive turn-on and turn-off phases in PWM configuration

Abbreviation	Definition
Suffix x	Related to the half-bridge x.
VGS_HSx	Gate-Source voltage of high-side MOSFET x.
IGS_HSx	Gate current of high-side MOSFET x. IGS_HSx is positive when the current flows out of GHx.
VGS_LSx	Gate-Source voltage of low-side MOSFET x.
IGS_LSx	Gate current of low-side MOSFET x. IGS_LSx is positive when the current flows out of GLx.
tPWM_SYNCH	Synchronization delay between external and internal PWM signal.
tHBxCCP ACTIVE	Active cross-current protection time of HBx. See control register <b>CCP_BLK</b> .
tHBxBLANK ACTIVE	Active Drain-source overvoltage blank time of HBx. See control register and <b>CCP_BLK</b> .
tHBxCCP FW	Freewheeling cross-current protection time of HBx. See control register <b>CCP_BLK</b> .

**Gate Drivers**

**Table 18 Abbreviations for adaptive turn-on and turn-off phases in PWM configuration (cont'd)**

<b>Abbreviation</b>	<b>Definition</b>
tHBxBLANK FW	Freewheeling drain-source overvoltage blank time of HBx. See control register and <b>CCP_BLK</b> .
PWMz	External PWM signal applied to the input pin PWMz.
ICHGMAXx	Maximum drive current of the half-bridge x during the pre-charge and pre-discharge phases. See control register <b>HB_ICHG_MAX</b> . IPRECHGx and IPREDCHGx are limited to ICHGMAXx.
IPRECHGx	Pre-charge current sourced by the gate driver to the active MOSFET of the half-bridge x during tPCHGx ( <b>TPRECHG</b> ). Internal and self-adaptive parameter (if AGC[1:0] = (1,0) or (1,1), <b>GENCTRL</b> ). IPRECHGx is clamped between $I_{CHG0}$ (0.5 mA typ.) and ICHGMAXx.
IPCHGINITx	Initial value of IPRECHGx. Refer to <b>HB_PCHG_INIT</b> .
IPREDCHGx	Pre-discharge-current sunk by the gate driver mapped to the half-bridge x during tPDCHGx. Internal and self-adaptive parameter (if AGC[1:0] = (1,0) or (1,1), <b>GENCTRL</b> ). IPREDCHGx is clamped between $I_{DCHG0}$ (0.5 mA typ.) and ICHGMAXx.
IPDCHGINITx	Initial value of IPREDCHGx. Refer to <b>HB_PCHG_INIT</b> .
ICHGx	Current sourced by the gate driver to the active MOSFET of the half-bridge x during the charge phase. See control register <b>HB_ICHG</b> .
IDCHGx	Current sunk by the gate driver to turn-off the active MOSFET of the half-bridge x during the discharge phase. See control register <b>HB_ICHG</b> .
ICHGFWx	Current sourced or sunk by the gate driver to turn on / turn off the freewheeling MOSFET of the half-bridge x. See control register <b>HB_ICHG</b> .
tPCHGx	Duration of the pre-charge phase of half-bridge x. tPCHGx is configurable by SPI. See control register <b>TPRECHG</b> .
tPDCHGx	Duration of the pre-discharge phase of half-bridge x. tPDCHGx is configurable by SPI. See control register <b>TPRECHG</b> .
tDONx	Turn-on delay of the active MOSFET of HBx.
tDOFFx	Turn-off delay of the active MOSFET of HBx.
IHOLD	Hold current sourced or sunk by the gate driver to keep the MOSFET in the desired state. See IHOLD control bit in <b>GENCTRL</b> .
IHARDOFF	IHARDOFF is the maximum current that the gate drivers can sink. It corresponds to the discharge current when IDCHGx[5:0] = 63 <sub>D</sub> (150 mA typ.).
TFVDS	Drain-Source overvoltage filter time. See <b>LS_VDS</b> .

### 9.3.3 PWM operation with 3 PWM inputs

Each half bridge are controlled by one input if PWM\_NB = 0 (see **CSA**) and HBx\_PWM\_EN (see **HBMODE**):

- PWM1/CRC controls HB1
- PWM3 controls HB2
- PWM5 controls HB3

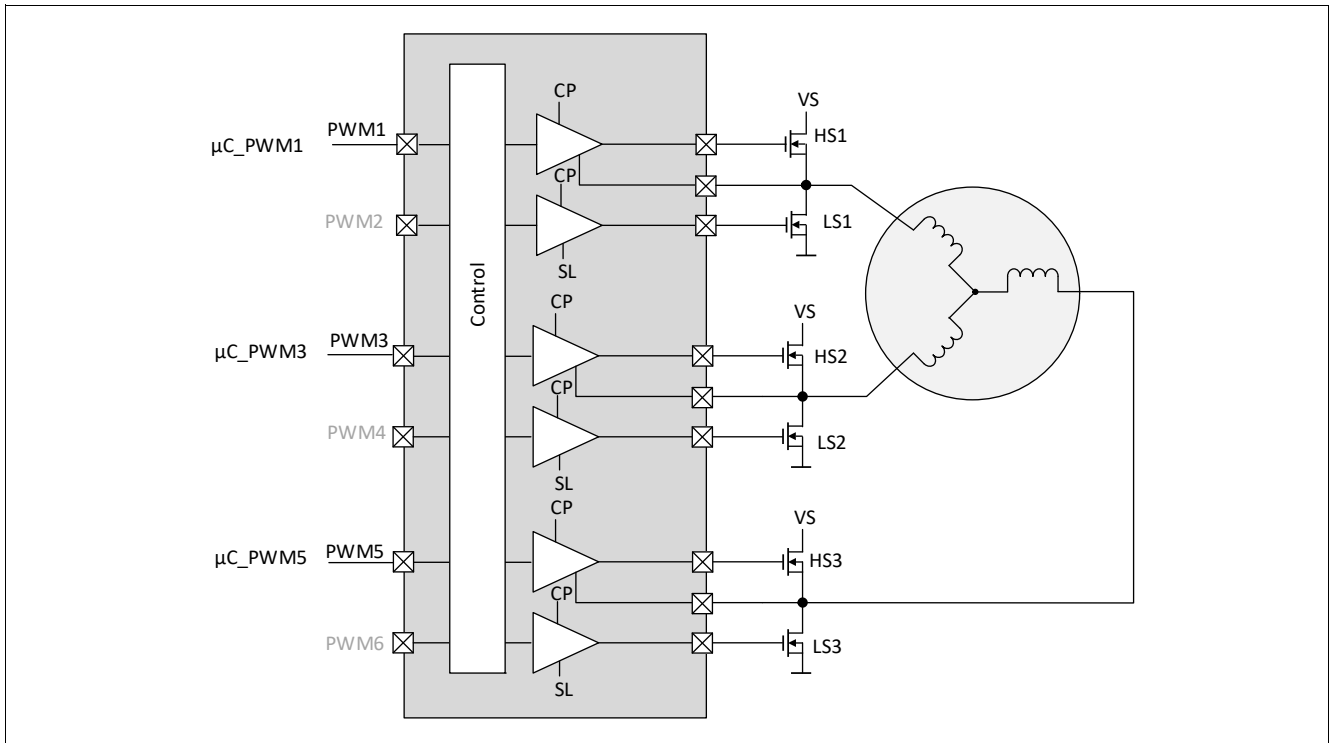

Figure 29 Half-bridge PWM control with three PWM inputs, PWM\_NB = 0

Table 19 Half-bridge PWM settings with 3 PWM inputs

PWM_NB	HBxPWM_EN <sup>1)</sup>	HBxMODE <sup>1)</sup>	AFW	Half-bridge x settings <sup>1)</sup>
0	Don't care	00 <sub>B</sub>	Don't care	LSx and HSx MOSFETs are kept OFF by the passive discharge
0	1	01 <sub>B</sub>	0	PWM signal applied to LSx PWM signal = 1: LSx, ON, HSx OFF PWM signal = 0: LSx OFF, HS x OFF
0	1	10 <sub>B</sub>	1	PWM signal applied to HSx PWM signal= 1: HSx, ON, LSx OFF PWM signal = 0: HSx OFF, LS x ON
0	Don't care	11 <sub>B</sub>	Don't care	LSx and HSx MOSFETs are actively kept OFF

1) x = 1 to 3

### 9.3.3.1 Control signals with active free-wheeling (AFW<sub>x</sub> = 1)

This section describes the MOSFET control signals with active freewheeling and HS PWM:

- The HS PWM MOSFET is the active MOSFET ([Chapter 9.3.3.1.1](#)).
- The HS PWM MOSFET is the free-wheeling MOSFET ([Chapter 9.3.3.1.2](#)).

#### 9.3.3.1.1 The PWM MOSFET is the active MOSFET

This section shows the control signals of the MOSFET when the PWM is the active MOSFET.

Gate Drivers

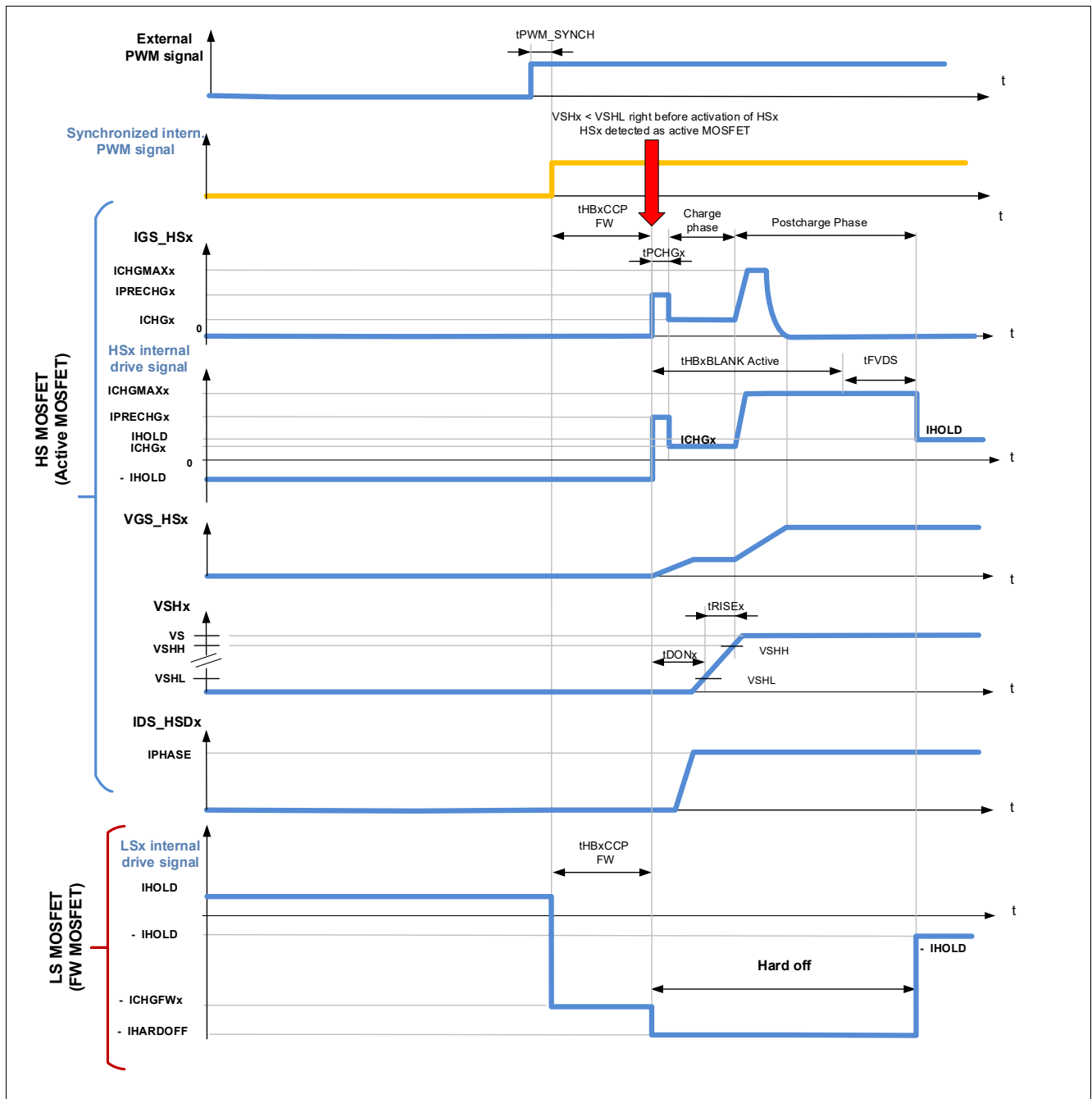

**Figure 30** Turn-on of an active MOSFET in PWM mode with active gate control, HS PWM, HS as active MOSFET, LS as FW MOSFET. PWM\_NB=0 (one PWM input per HB), HBxMODE = 10<sub>B</sub> (HS PWM), AGC = 01<sub>B</sub> or 10<sub>B</sub> (Active Gate Control), EN\_GEN\_CHECK=1 (detection of active / FW MOSFET), AFWx = 1 (active freewheeling for HBx is activated)

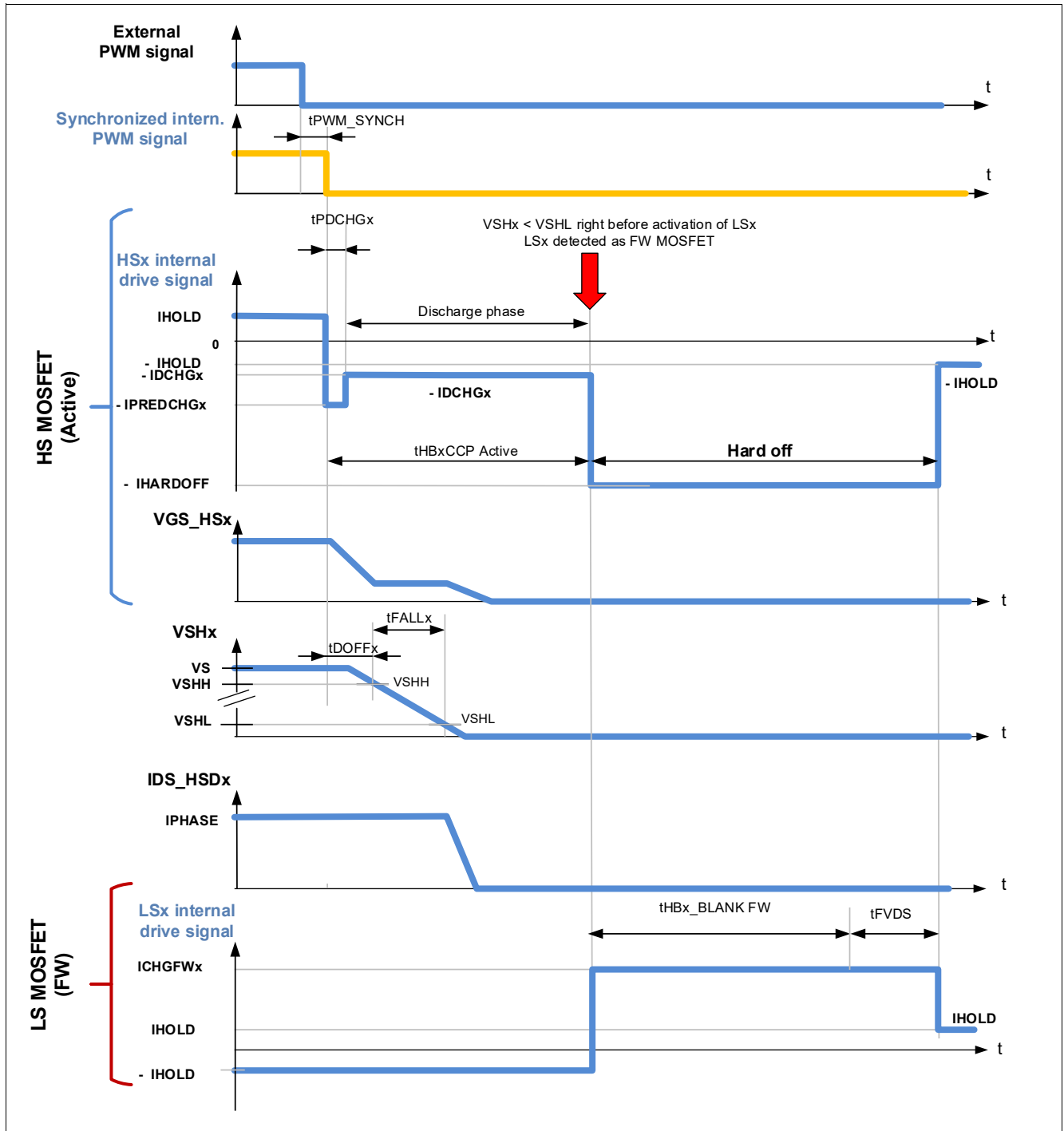
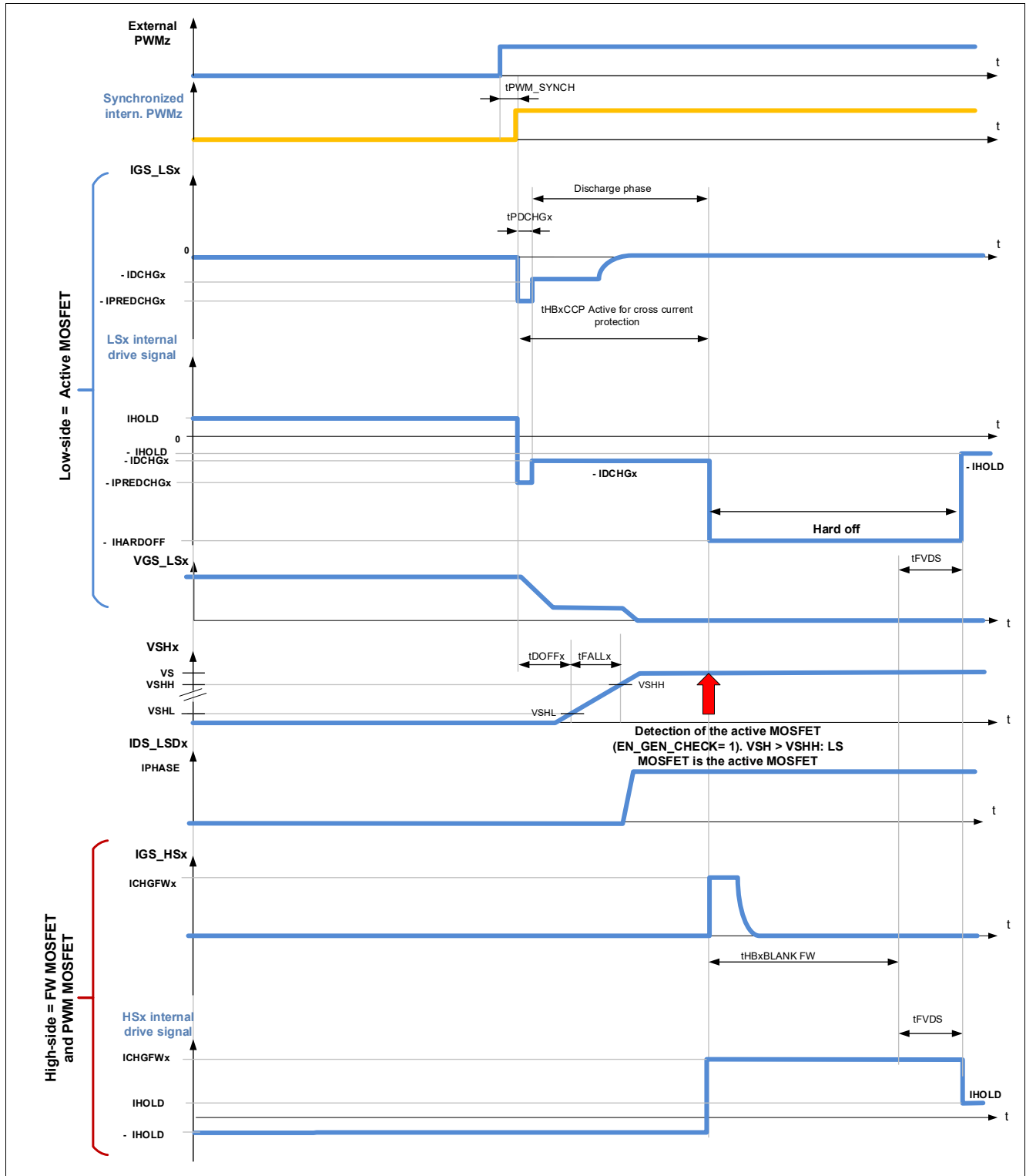

**Figure 31** Turn-off of an active MOSFET in PWM mode with active gate control, HS PWM, HS as active MOSFET, LS as FW MOSFET. PWM\_NB = 0 (one PWM input per HB), HBxMODE = 10<sub>B</sub> (HS PWM), AGC = 01<sub>B</sub> or 10<sub>B</sub> (Active Gate Control), EN\_GEN\_CHECK = 1 (detection of active / FW MOSFET), AFWx = 1 (active freewheeling for HBx is activated)



### 9.3.3.1.2 The PWM MOSFET is the free-wheeling MOSFET

This section shows the control signals of the MOSFET when the PWM is the free-wheeling MOSFET.



**Figure 32** PWM rising edge - PWM mode with active gate control, HS PWM (HBxMODE = 10<sub>B</sub>), LS as active MOSFET, HS as FW MOSFET. PWM\_NB=0 (one PWM input per HB), AGC = 01<sub>B</sub> or 10<sub>B</sub> (Active Gate Control), EN\_GEN\_CHECK=1 (detection of active / FW MOSFET), AFWx = 1 (active freewheeling for HBx is activated)

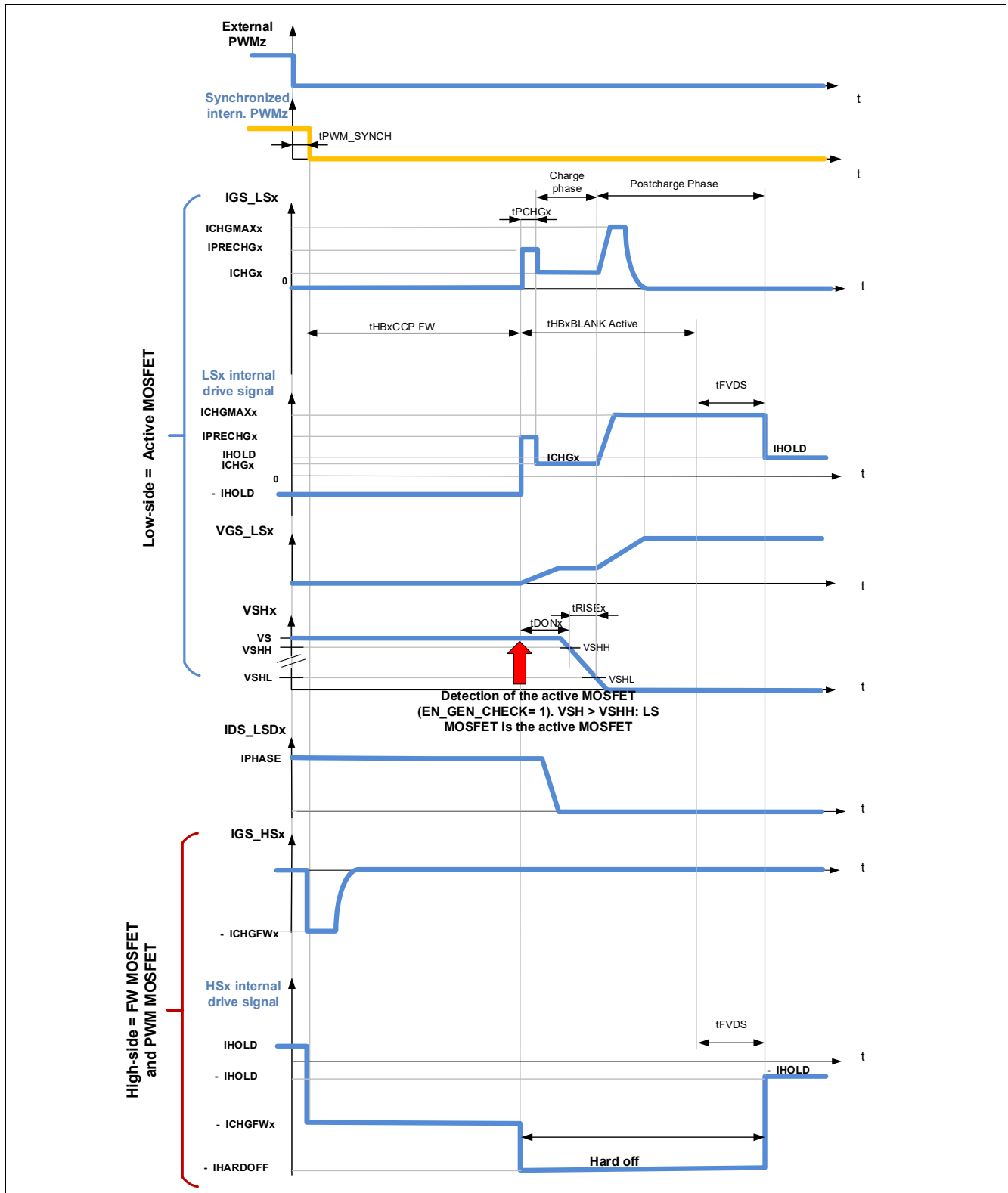

**Figure 33** PWM falling edge - PWM mode with active gate control, HS PWM (HBxMODE = 10<sub>B</sub>), LS as active MOSFET, HS as FW MOSFET. PWM\_NB=0 (one PWM input per HB), AGC = 01<sub>B</sub> or 10<sub>B</sub> (Active Gate Control), EN\_GEN\_CHECK=1 (detection of active / FW MOSFET), AFWx = 1 (active freewheeling for HBx is activated)

### **9.3.3.2 Control signals with passive free-wheeling (AFW<sub>x</sub> = 0)**

This section describes the MOSFET control signals with active freewheeling and HS PWM:

- The HS PWM MOSFET is the active MOSFET ([Chapter 9.3.3.2.1](#)).
- The HS PWM MOSFET is the free-wheeling MOSFET ([Chapter 9.3.3.2.2](#)).

#### **9.3.3.2.1 The PWM MOSFET is the active MOSFET**

This section shows the control signals of the MOSFET when the PWM is the active MOSFET.

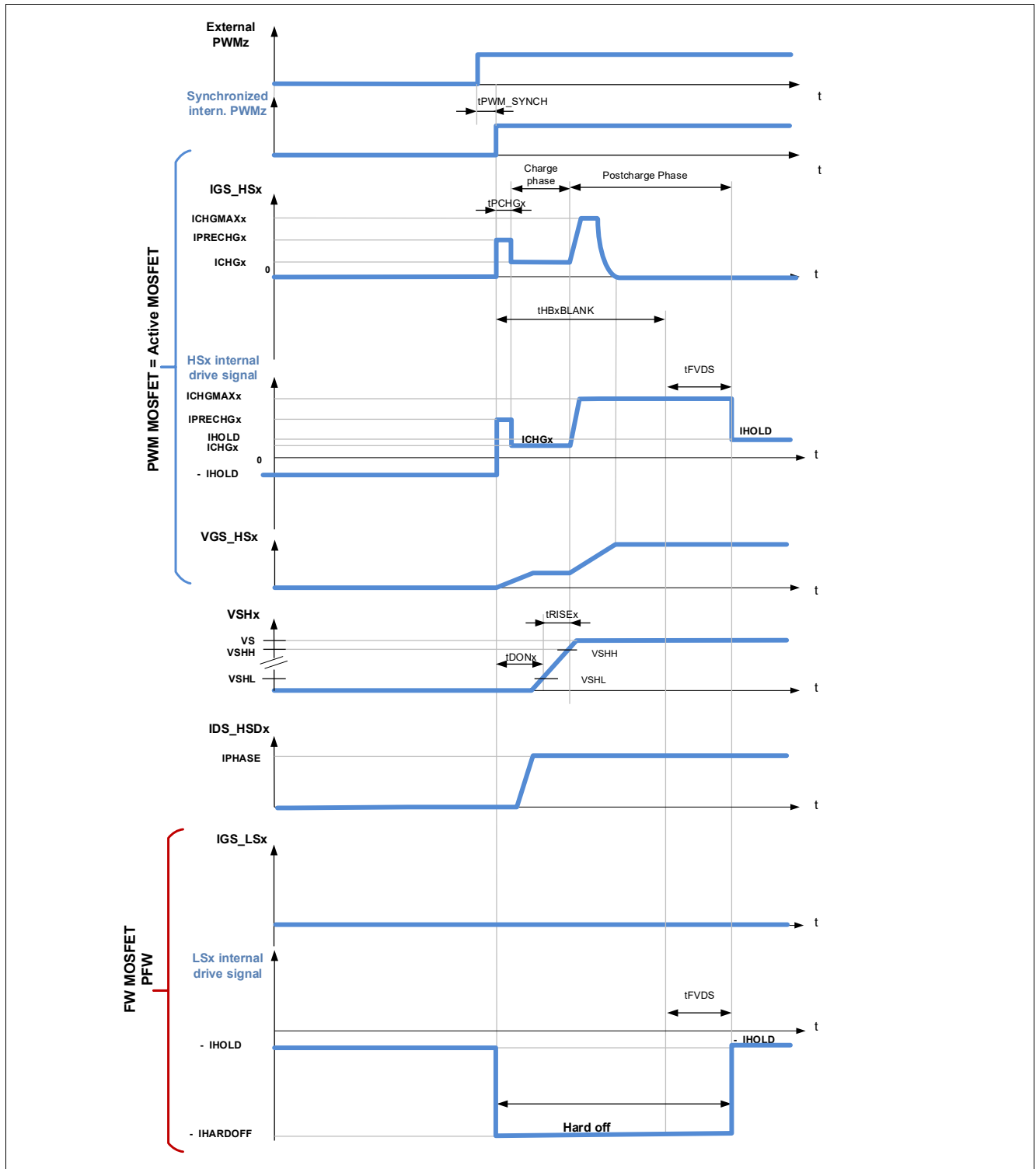
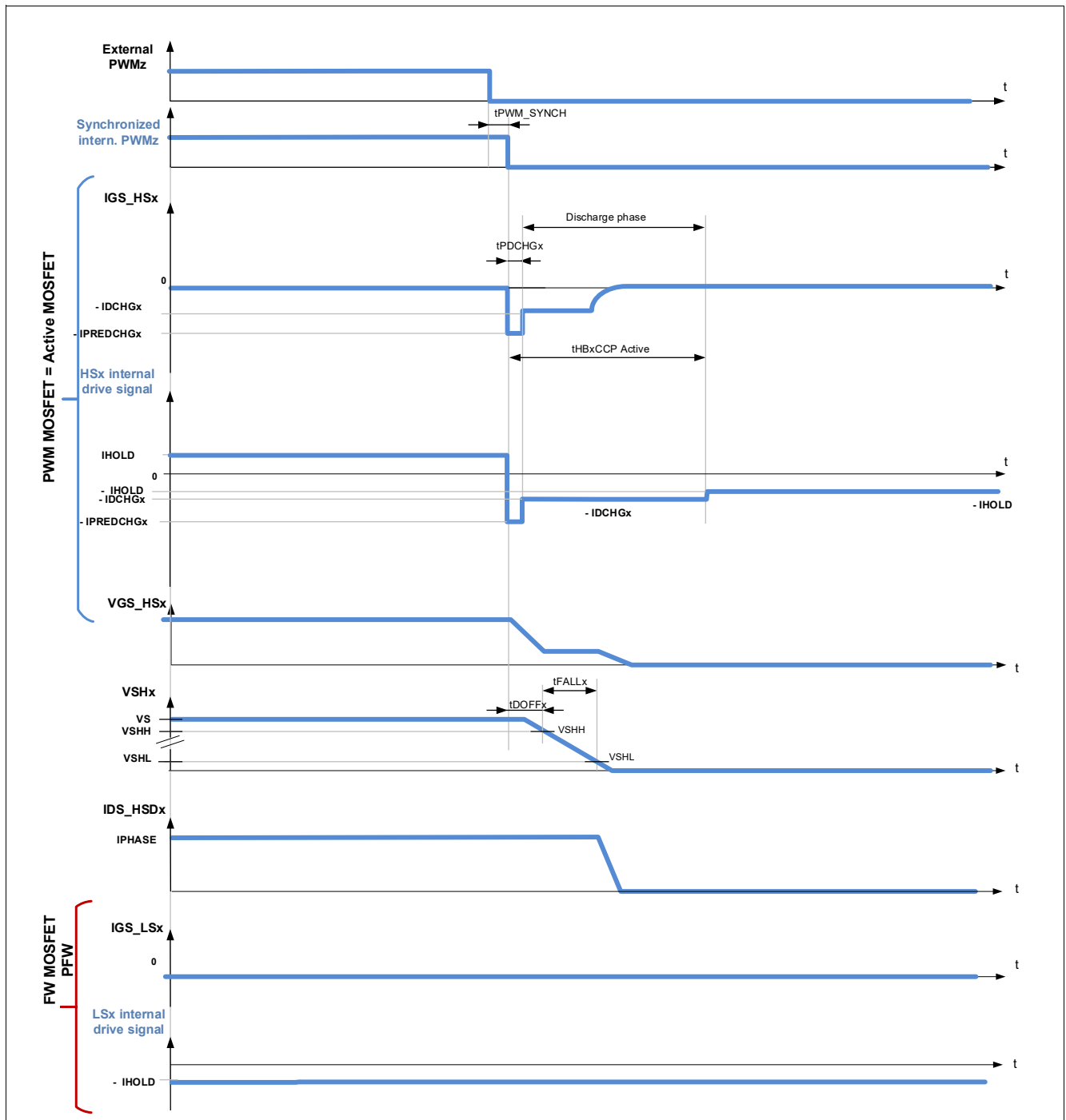

Figure 34 Adaptive turn-on with high-side PWM,  $AGC[1:0] = (1,0)$  or  $(1,1)$ ,  $AFWx=0$ ,  $POCHGDIS=0$ , the PWM MOSFET is the active MOSFET.  $PWM\_NB=0$ .



**Figure 35 Adaptive turn-off with high-side PWM, AGC[1:0] = (1,0) or (1,1), AFWx=0, POCHGDIS=0, the PWM MOSFET is the active MOSFET. PWM\_NB=0.**

### 9.3.3.2.2 The PWM MOSFET is the free-wheeling MOSFET

This section shows the control signals of the MOSFET when the PWM is the free-wheeling MOSFET.

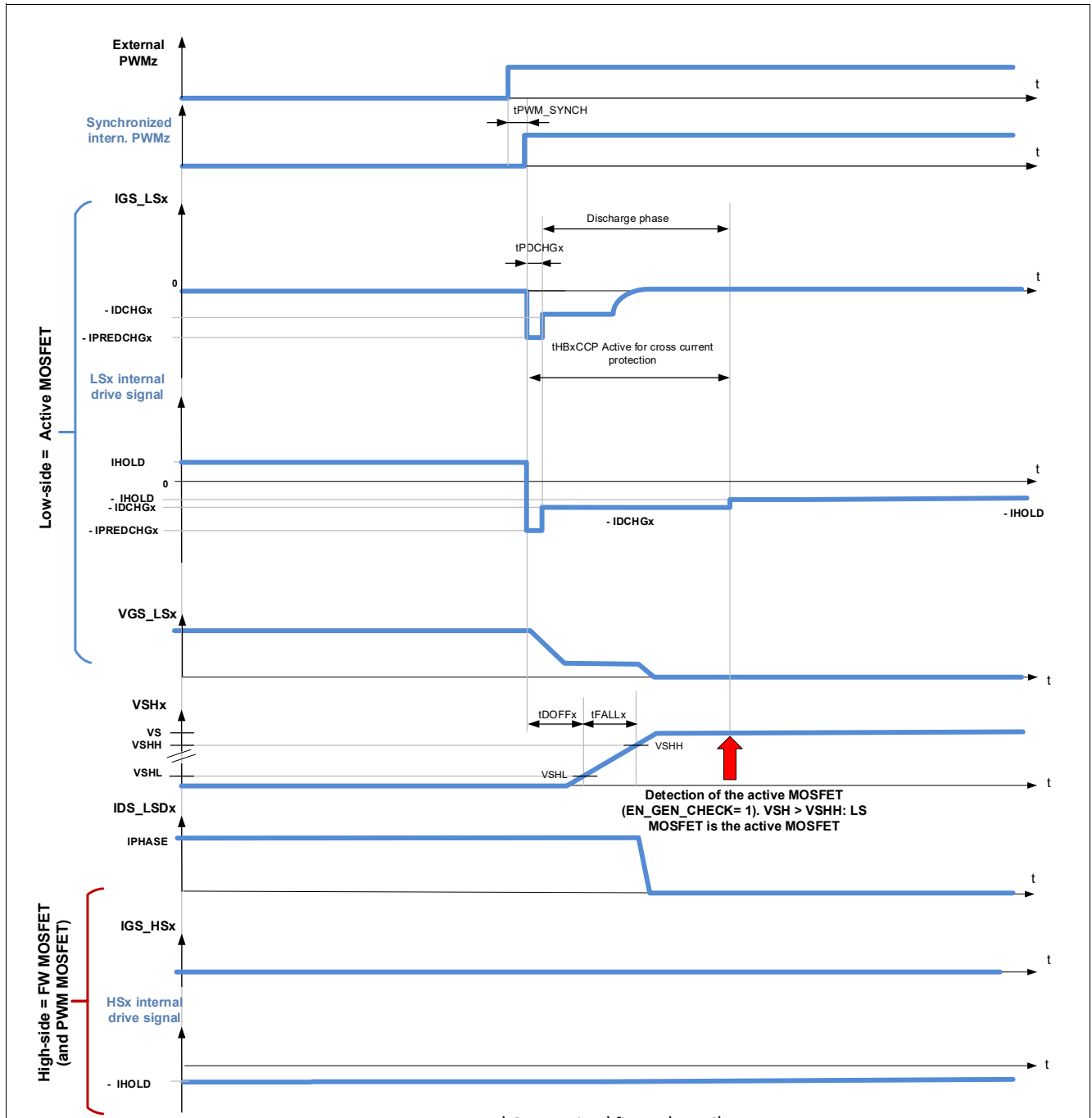

**Figure 36** PWM rising edge with adaptive control, EN\_GEN\_CHECK = 1 with high-side PWM, AGC[1:0] = (1,0) or (1,1), AFWx=0, POCHGDIS=0. The PWM MOSFET is the FW MOSFET. PWM\_NB=0.

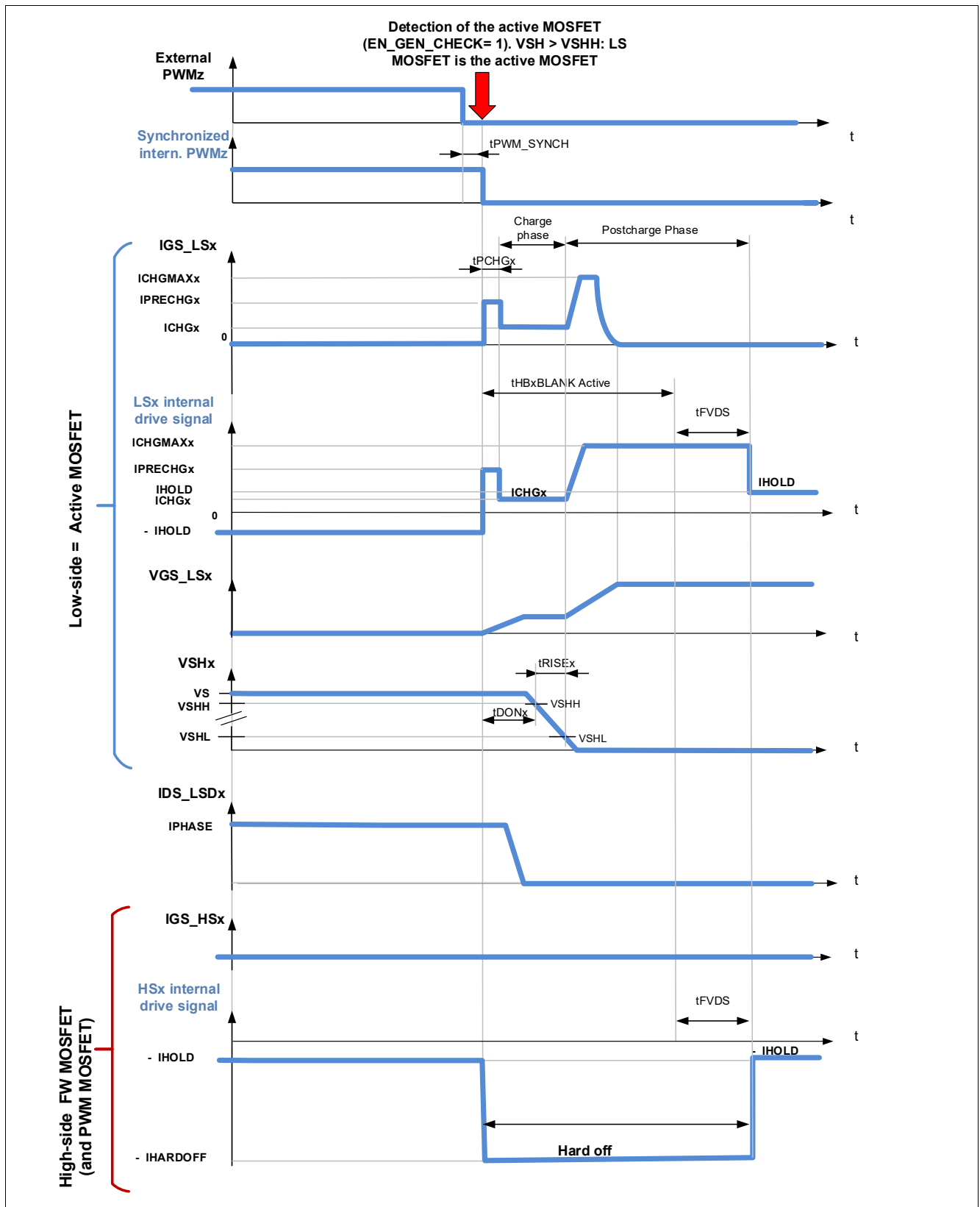

Figure 37 PWM falling edge with adaptive control, EN\_GEN\_CHECK = 1 with high-side PWM, AGC[1:0] = (1,0) or (1,1), AFWx=0, POCHGDIS=0. The PWM MOSFET is the FW MOSFET. PWM\_NB=0.

### 9.3.3.3 Time modulation of pre-charge and pre-discharge times

If DEEP\_ADAP =0:

## Gate Drivers

- one single precharge current is applied during  $t_{PCHGx}$  to regulate TDON
- one single precharge current is applied during  $t_{PDCHGx}$  to regulate TDOFF

If **DEEP\_ADAP** = 1 (“deep adaptation” or “time modulation”) it is possible to:

- to divide the precharge phase in two parts, during which two different precharge currents can be applied
- to divide the pre-discharge phase in two parts, during which two different precharge currents can be applied

**Figure 38** describes the principle of the time modulation applied to the precharge phase. The same principle is also applied for the regulation of the pre-discharge phase.



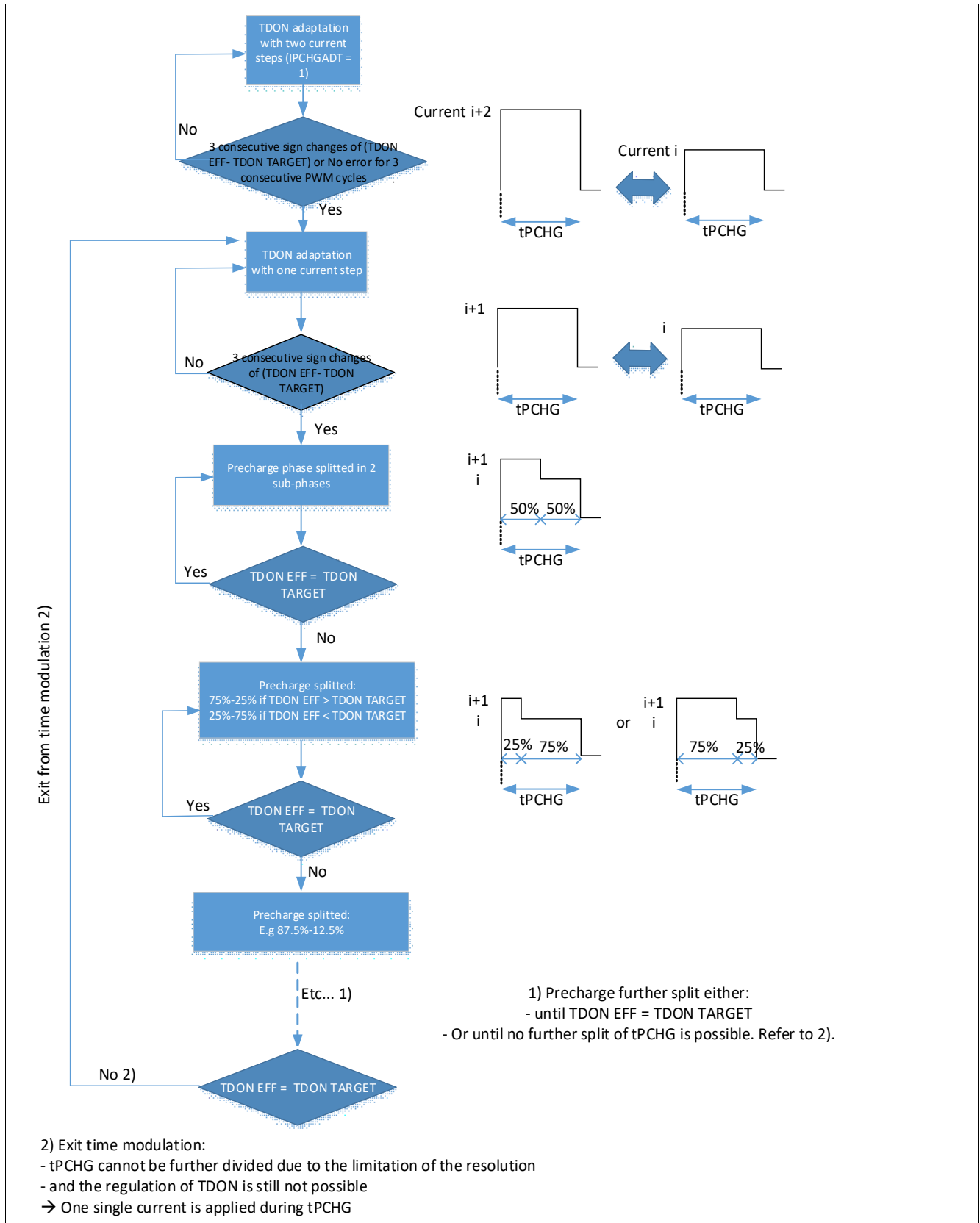

Figure 38 Principle of the time modulation of the precharge phase, DEEP\_ADAP = 1, AGC = 10<sub>B</sub> or 11<sub>B</sub>

### 9.3.3.4 Operation at high and low duty cycles

In the particular cases where the on-time is shorter than  $t_{HBxCCP}$  FW or the off-time of the PWM signal is shorter than  $t_{HBxCCP}$  Active:

- No distinction between active MOSFET and FW MOSFET is possible. Therefore PWM MOSFET (selected by  $HBxMODE[1:0]$ ) is controlled as active MOSFET.
- The MOSFET opposite to the PWM MOSFET stays off (passive FW)

### 9.3.3.5 Measurements of the switching times

The effective switching times in PWM operation:

- of the PWM MOSFET if  $EN\_GEN\_CHECK = 0$
- of the active MOSFET if  $EN\_GEN\_CHECK = 1$

are reported in the registers:

**$EFF\_TDON\_OFF1, EFF\_TDON\_OFF2, EFF\_TDON\_OFF3$ .**

If the end of the rise time for a given MOSFET is not detected before  $t_{HBxBLANK}$  Active elapses, then the corresponding status register reports an effective rise time equal to zero.

If the end of the fall time for a given MOSFET is not detected before  $t_{HBxCCP}$  Active active elapses, then the corresponding status register reports an effective fall time equal to zero.

The device cannot measure the switching times  $t_{DON}$ ,  $t_{DOFF}$ ,  $t_{RISE}$  and  $t_{FALL}$  at very high and very low duty cycles:  $t_{ON} < t_{HBxCCP}$  FW and  $t_{OFF} < t_{HBxCCP}$  active. In this case, the corresponding registers report effective  $t_{DON}$ ,  $t_{DOFF}$ ,  $t_{RISE}$  and  $t_{FALL}$  equal to zero.

### 9.3.4 PWM operation with 6 PWM inputs

Each high-side MOSFET and each low-side MOSFET is controlled by one PWM input. if PWM\_NB is set to 1 (see [CSA](#)) and HBx\_PWM\_EN are set to 1 (see [HBMODE](#)). Refer to [Table 20](#).

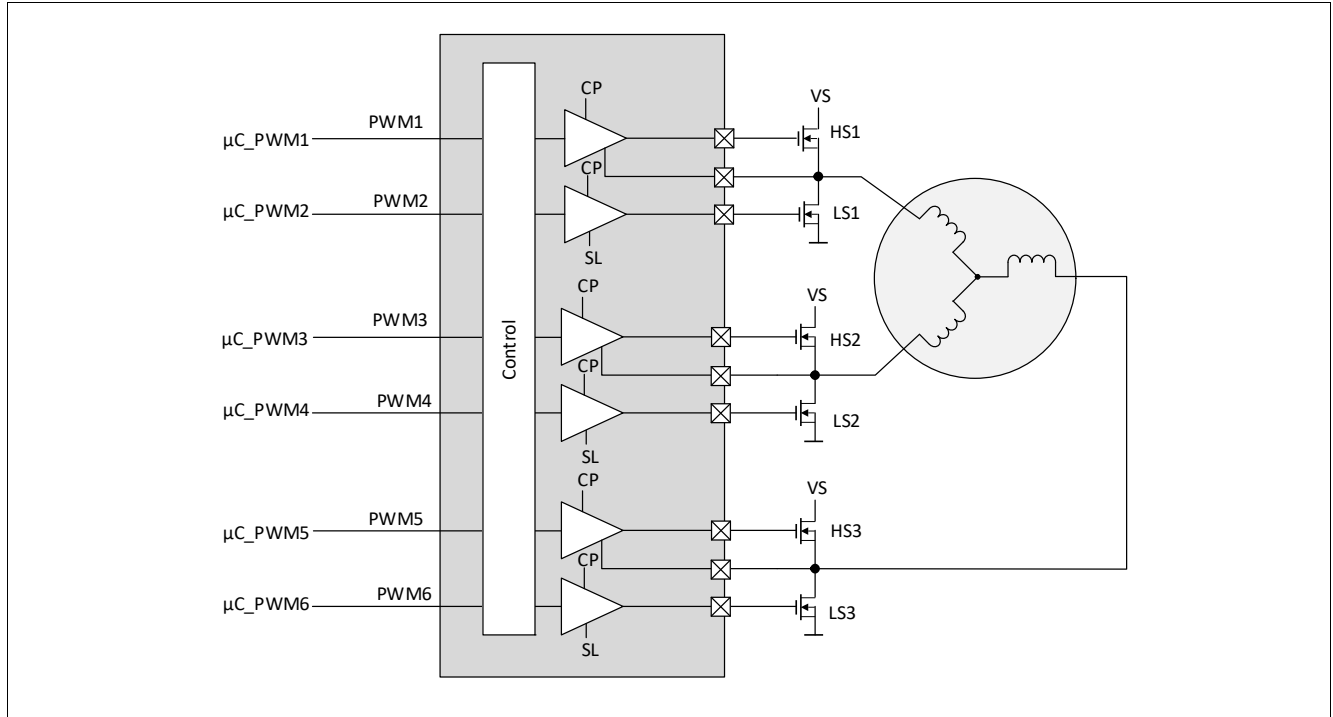

Figure 39 Half-bridge PWM control with six PWM inputs, PWM\_NB = 1

Table 20 Half-bridge PWM settings with 6 PWM inputs (PWM\_NB = 1)FW and Active MOSFET

PWM_NB	HBx_PWM_EN <sup>1)</sup>	HBxMODE <sup>1)</sup>	Half-bridge x settings <sup>1)</sup>
1	Don't care	00 <sub>B</sub>	LSx and HSx MOSFETs are kept OFF by the passive discharge (default)
1	1	01 <sub>B</sub>	HBx is controlled by its PWM inputs <ul style="list-style-type: none"> <li>If <a href="#">EN_GEN_CHECK</a> = 0: LSx is always considered as the active MOSFET</li> <li>If <a href="#">EN_GEN_CHECK</a> = 1: The active and the FW MOSFETs are detected according to <a href="#">Chapter 9.3.1</a>, independently from HBxMODE</li> </ul>
1	1	10 <sub>B</sub>	HBx is controlled by its PWM inputs <ul style="list-style-type: none"> <li>If <a href="#">EN_GEN_CHECK</a> = 0: HSx is always considered as the active MOSFET</li> <li>If <a href="#">EN_GEN_CHECK</a> = 1: The active and the FW MOSFETs are detected according to <a href="#">Chapter 9.3.1</a> independently from HBxMODE</li> </ul>
1	Don't care	11 <sub>B</sub>	LSx and HSx MOSFETs are actively kept OFF

1) x = 1 to 3

Gate Drivers

**Table 21 PWM Control of HS1 and LS1, PWM\_NB = 1, HB1\_PWM\_EN = 1**

HB1MODE[1:0]	PWM1/CRC	PWM2	HS1	LS1
01	Low	Low	OFF	OFF
01	Low	High	OFF	ON
01	High	Low	ON	OFF
01	High	High	OFF	OFF
10	Low	Low	OFF	OFF
10	Low	High	OFF	ON
10	High	Low	ON	OFF
10	High	High	OFF	OFF

**Table 22 PWM Control of HS2 and LS2, PWM\_NB = 1, HB2\_PWM\_EN = 1**

HB2MODE[1:0]	PWM3	PWM4	HS2	LS2
01	Low	Low	OFF	OFF
01	Low	High	OFF	ON
01	High	Low	ON	OFF
01	High	High	OFF	OFF
10	Low	Low	OFF	OFF
10	Low	High	OFF	ON
10	High	Low	ON	OFF
10	High	High	OFF	OFF

**Table 23 PWM Control of HS3 and LS3, PWM\_NB = 1, HB3\_PWM\_EN = 1**

HB3MODE[1:0]	PWM5	PWM6	HS3	LS3
01	Low	Low	OFF	OFF
01	Low	High	OFF	ON
01	High	Low	ON	OFF
01	High	High	OFF	OFF
10	Low	Low	OFF	OFF
10	Low	High	OFF	ON
10	High	Low	ON	OFF
10	High	High	OFF	OFF

**Figure 40** shows the PWM control of HBx in PWM (HBx\_PWM\_EN = 1): Turn-off of the FW MOSFET (low-side MOSFET in this case) followed by the activation of the active MOSFET (high-side MOSFET in this case)<sup>1)</sup> with PWM\_NB = 1, AGC[1:0]=01<sub>B</sub> or 10<sub>B</sub>, **POCHGDIS** = 0 (post-charge enabled).

This control scheme is applicable for the following cases:

1) If the synchronized HS PWM rising edge occurs after tHBxCCP FW and before the end of tOFF timeout FW, then the LS MOSFET is discharged with IHARDOFF and the HS is turned on, when the HS PWM rising edge is detected

### Gate Drivers

1. **EN\_GEN\_CHECK** = 0 (detection of FW/Active MOSFET disabled); HBxMODE[1:0] = 10<sub>B</sub> (HS MOSFET is considered as active MOSFET by default).
2. **EN\_GEN\_CHECK** = 1 (detection of active / FW MOSFET enabled); HS MOSFET detected as active MOSFET; HBxMODE[1:0] = 01<sub>B</sub> or 10<sub>B</sub>.

*Note: If the synchronized HS PWM rising edge occurs before the end of tHBxCCP active, then the device prevents an activation of the HS MOSFET until tHBxCCP FW elapses. In other words, the HS PWM rising edge is ignored until the end of tHBxCCP FW.*

Gate Drivers

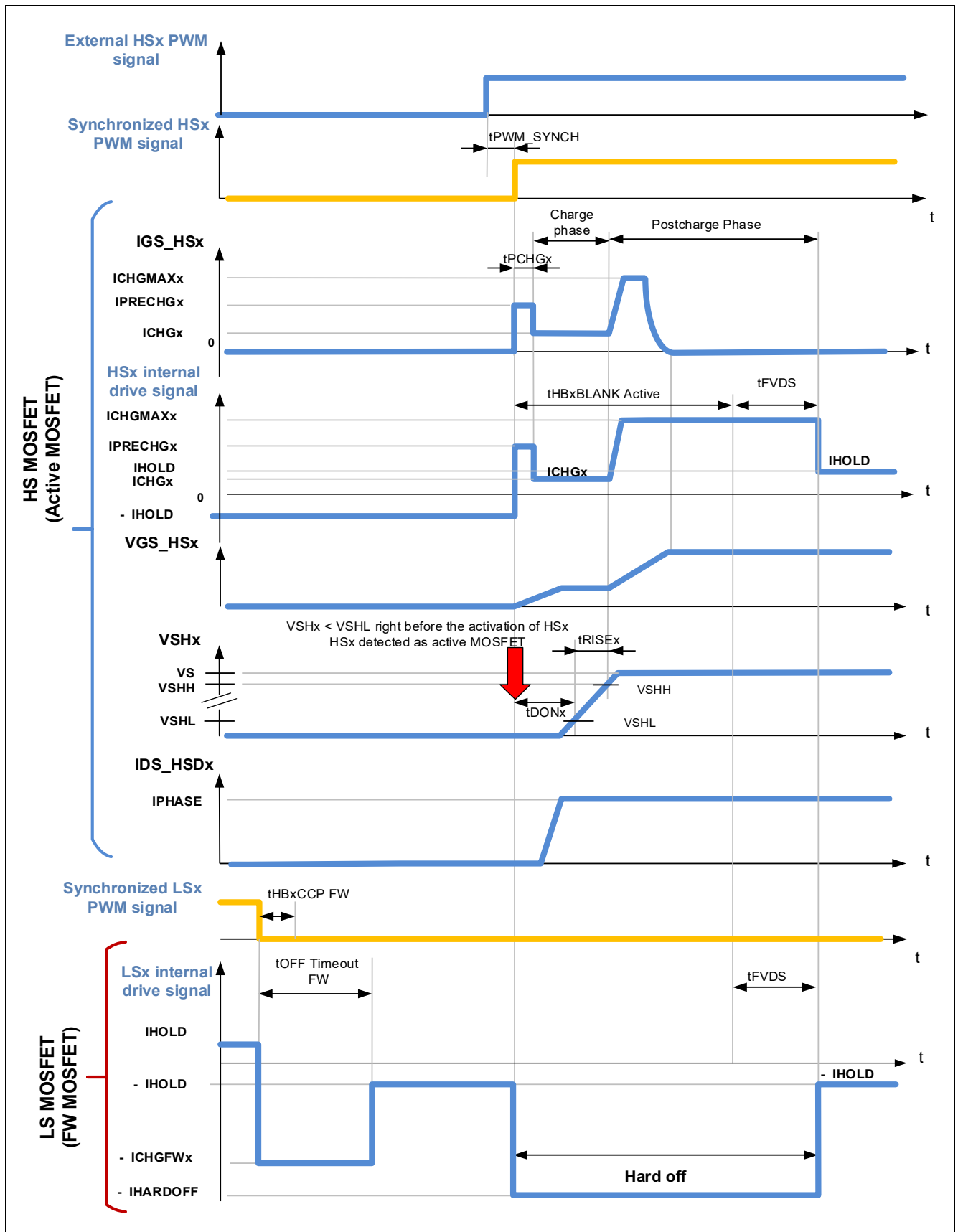

Figure 40 Turn-on of an active MOSFET in PWM mode with active gate control, HS as active MOSFET, LS as FW MOSFET. Two PWM inputs per half-bridge, active gate control enabled. PWM\_EN = 1

---

**Gate Drivers**

**Figure 41** shows the PWM control of HBx in PWM (HBx\_PWM\_EN = 1): Turn-off of the active MOSFET (high-side MOSFET in this case) followed by the activation of the FW MOSFET low-side MOSFET in this case) with PWM\_NB = 1, AGC[1:0] = 01<sub>B</sub> or 10<sub>B</sub>, **POCHDIS** = 0 (post-charge enabled).

This control scheme is applicable for the following cases:

1. **EN\_GEN\_CHECK** = 0 (detection of FW/Active MOSFET disabled); HBxMODE[1:0] = 10<sub>B</sub> (HS MOSFET is considered as active MOSFET by default).
2. **EN\_GEN\_CHECK** = 1 (detection of active / FW MOSFET enabled); HS MOSFET detected as active MOSFET; HBxMODE[1:0] = 01<sub>B</sub> or 10<sub>B</sub>.

*Note: If the synchronized LS PWM rising edge occurs before the end of tHBxCCP active, then the device prevents an activation of the LS MOSFET until tHBxCCP active elapses. In other words, the LS PWM rising edge is ignored until the end of tHBxCCP active.*

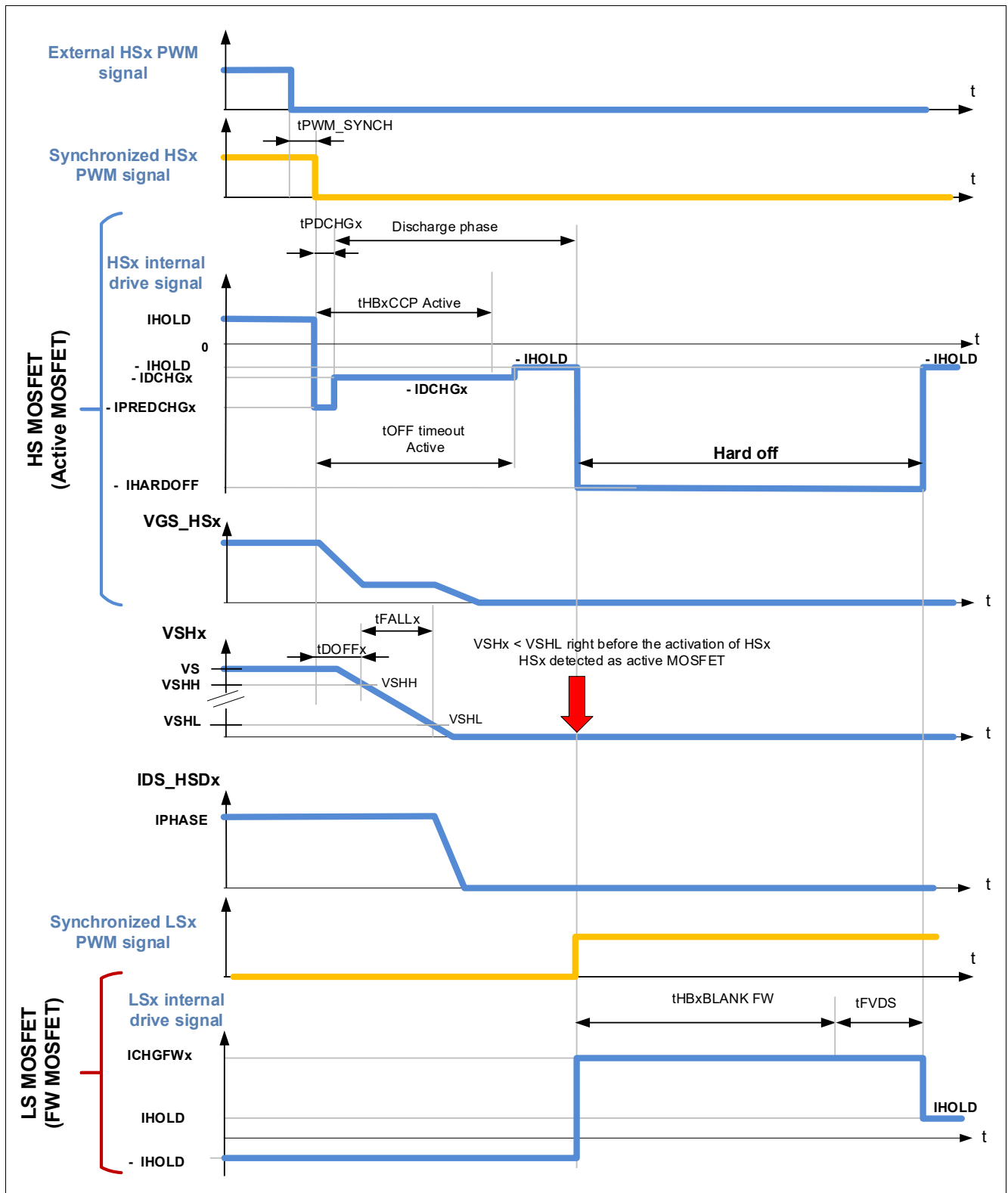

Figure 41 Turn-off of an active MOSFET in PWM mode with active gate control, HS as active MOSFET, LS as FW MOSFET. two PWM inputs per half-bridge, active gate control enabled. PWM\_NB=1.

### 9.3.5 Status bits for regulation of turn-on and turn-off delay times

The control bits TDREGx (**TDREG**) indicate if  $t_{DONx}$  and  $t_{DOFFx}$  of the half-bridge x, using the adaptive control scheme ( $AGC = 10_B$  or  $11_B$ ), are in regulation.



The half-bridge x is considered in regulation if one of the following conditions is met:

- Condition 1: The effective turn-on and turn-off delays are equal to the configured delays for at least eight cumulative PWM cycle (HBx tDON counter  $\geq 8$  and HBx tDOFF counter  $\geq 8$ ). For each PWM cycle
  - if  $t_{\text{DONxEFF}}^{1)} = T_{\text{DONx}}^{2)}$ ,  $x = 1..3$ , HBx tDON counter is incremented
  - if  $t_{\text{DONxEFF}}^{1)} \neq T_{\text{DONx}}^{2)}$ ,  $x = 1..3$ , HBx tDON counter is decremented
  - if  $t_{\text{DOFFxEFF}}^{1)} = T_{\text{DOFFx}}^{3)}$ ,  $x = 1..3$ , HBx tDOFF counter is incremented
  - if  $t_{\text{DOFFxEFF}}^{1)} \neq T_{\text{DOFFx}}^{3)}$ ,  $x = 1..3$ , HBx tDOFF counter is decremented
- Condition 2: The error between the effective delays (( $t_{\text{DONxEFF}} - T_{\text{DONx}}$ ) and ( $t_{\text{DOFFxEFF}} - T_{\text{DOFFx}}$ )) changes its sign three times consecutively

1) Refer to [EFF\\_TDON\\_OFF1](#), [EFF\\_TDON\\_OFF2](#), [EFF\\_TDON\\_OFF3](#)

2) Refer to [TDON\\_HB\\_CTRL](#)

3) Refer to [TDOFF\\_HB\\_CTRL](#)

### 9.3.6 Gate driver current

Each gate driver is able to source and sink currents from 0.5 mA to 150 mA, with 64 steps.

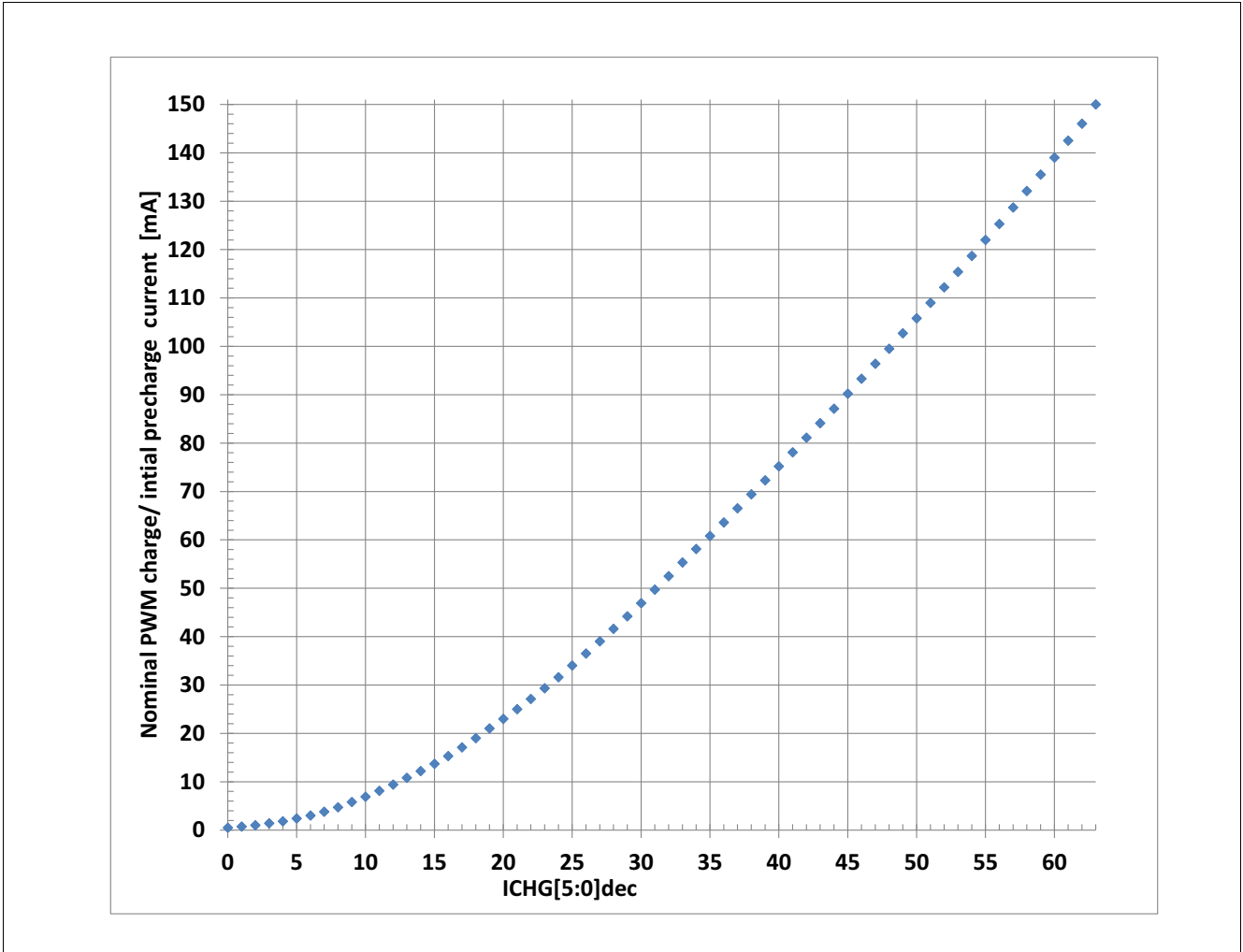

Figure 42 Configurable charge currents in PWM operation

**Gate Drivers**

**Table 24 Charge currents and initial precharge currents**

<b>ICHGx[5:0], PCHGINITx[5:0]</b>	<b>Parameter name</b>	<b>Nom. current [mA]</b>	<b>Max. deviation to nominal values [%]</b>
00000 <sub>B</sub>	$I_{CHG0}$	0.5	+/- 60%
000001 <sub>B</sub>	$I_{CHG1}$	0.7	+/- 60 %
000010 <sub>B</sub>	$I_{CHG2}$	1.0	+/- 60 %
000011 <sub>B</sub>	$I_{CHG3}$	1.4	+/- 60 %
000100 <sub>B</sub>	$I_{CHG4}$	1.8	+/- 60 %
000101 <sub>B</sub>	$I_{CHG5}$	2.4	+/- 60 %
000110 <sub>B</sub>	$I_{CHG6}$	3.0	+/- 60 %
000111 <sub>B</sub>	$I_{CHG7}$	3.8	+/- 60 %
001000 <sub>B</sub>	$I_{CHG8}$	4.7	+/- 55%
001001 <sub>B</sub>	$I_{CHG9}$	5.8	+/- 55%
001010 <sub>B</sub>	$I_{CHG10}$	6.9	+/- 55%
001011 <sub>B</sub>	$I_{CHG11}$	8.1	+/- 55%
001100 <sub>B</sub>	$I_{CHG12}$	9.4	+/- 55%
001101 <sub>B</sub>	$I_{CHG13}$	10.8	+/- 55%
001110 <sub>B</sub>	$I_{CHG14}$	12.2	+/- 40%
001111 <sub>B</sub>	$I_{CHG15}$	13.7	+/- 40%
010000 <sub>B</sub>	$I_{CHG16}$	15.3	+/- 40 %
010001 <sub>B</sub>	$I_{CHG17}$	17.1	+/- 40 %
010010 <sub>B</sub>	$I_{CHG18}$	19	+/- 40%
010011 <sub>B</sub>	$I_{CHG19}$	21	+/- 40 %
010100 <sub>B</sub>	$I_{CHG20}$	23	+/- 40%
010101 <sub>B</sub>	$I_{CHG21}$	25	+/- 40 %
010110 <sub>B</sub>	$I_{CHG22}$	27.1	+/- 40 %
010111 <sub>B</sub>	$I_{CHG23}$	29.3	+/- 40 %
011000 <sub>B</sub>	$I_{CHG24}$	31.6	+/- 40 %
011001 <sub>B</sub>	$I_{CHG25}$	34	+/- 40 %
011010 <sub>B</sub>	$I_{CHG26}$	36.5	+/- 40 %
011011 <sub>B</sub>	$I_{CHG27}$	39	+/- 40 %
011100 <sub>B</sub>	$I_{CHG28}$	41.6	+/- 40 %
011101 <sub>B</sub>	$I_{CHG29}$	44.2	+/- 30 %
011110 <sub>B</sub>	$I_{CHG30}$	46.9	+/- 30 %
011111 <sub>B</sub>	$I_{CHG31}$	49.7	+/- 30 %
100000 <sub>B</sub>	$I_{CHG32}$	52.5	+/- 30 %
100001 <sub>B</sub>	$I_{CHG33}$	55.3	+/- 30 %
100010 <sub>B</sub>	$I_{CHG34}$	58.1	+/- 30 %
100011 <sub>B</sub>	$I_{CHG35}$	60.8	+/- 30 %

**Gate Drivers**

**Table 24 Charge currents and initial precharge currents (cont'd)**

<b>ICHGx[5:0], PCHGINITx[5:0]</b>	<b>Parameter name</b>	<b>Nom. current [mA]</b>	<b>Max. deviation to nominal values [%]</b>
100100 <sub>B</sub>	$I_{CHG36}$	63.6	+/- 30 %
100101 <sub>B</sub>	$I_{CHG37}$	66.5	+/- 30 %
100110 <sub>B</sub>	$I_{CHG38}$	69.4	+/- 30 %
100111 <sub>B</sub>	$I_{CHG39}$	72.3	+/- 30 %
101000 <sub>B</sub>	$I_{CHG40}$	75.2	+/- 30 %
101001 <sub>B</sub>	$I_{CHG41}$	78.1	+/- 30 %
101010 <sub>B</sub>	$I_{CHG42}$	81.1	+/- 30 %
101011 <sub>B</sub>	$I_{CHG43}$	84.1	+/- 30 %
101100 <sub>B</sub>	$I_{CHG44}$	87.1	+/- 30 %
101101 <sub>B</sub>	$I_{CHG45}$	90.2	+/- 30 %
101110 <sub>B</sub>	$I_{CHG46}$	93.3	+/- 30 %
101111 <sub>B</sub>	$I_{CHG47}$	96.4	+/- 30 %
110000 <sub>B</sub>	$I_{CHG48}$	99.5	+/- 30 %
110001 <sub>B</sub>	$I_{CHG49}$	102.7	+/- 30 %
110010 <sub>B</sub>	$I_{CHG50}$	105.8	+/- 30 %
110011 <sub>B</sub>	$I_{CHG51}$	109	+/- 30 %
110100 <sub>B</sub>	$I_{CHG52}$	112.2	+/- 30 %
110101 <sub>B</sub>	$I_{CHG53}$	115.4	+/- 30 %
110110 <sub>B</sub>	$I_{CHG54}$	118.7	+/- 30 %
110111 <sub>B</sub>	$I_{CHG55}$	122	+/- 30 %
111000 <sub>B</sub>	$I_{CHG56}$	125.3	+/- 30 %
111001 <sub>B</sub>	$I_{CHG57}$	128.7	+/- 30 %
111010 <sub>B</sub>	$I_{CHG58}$	132.1	+/- 30 %
111011 <sub>B</sub>	$I_{CHG59}$	135.5	+/- 30 %
111100 <sub>B</sub>	$I_{CHG60}$	139	+/- 30 %
111101 <sub>B</sub>	$I_{CHG61}$	142.5	+/- 30 %
111110 <sub>B</sub>	$I_{CHG62}$	146	+/- 30 %
111111 <sub>B</sub>	$I_{CHG63}$	150	+/- 30 %

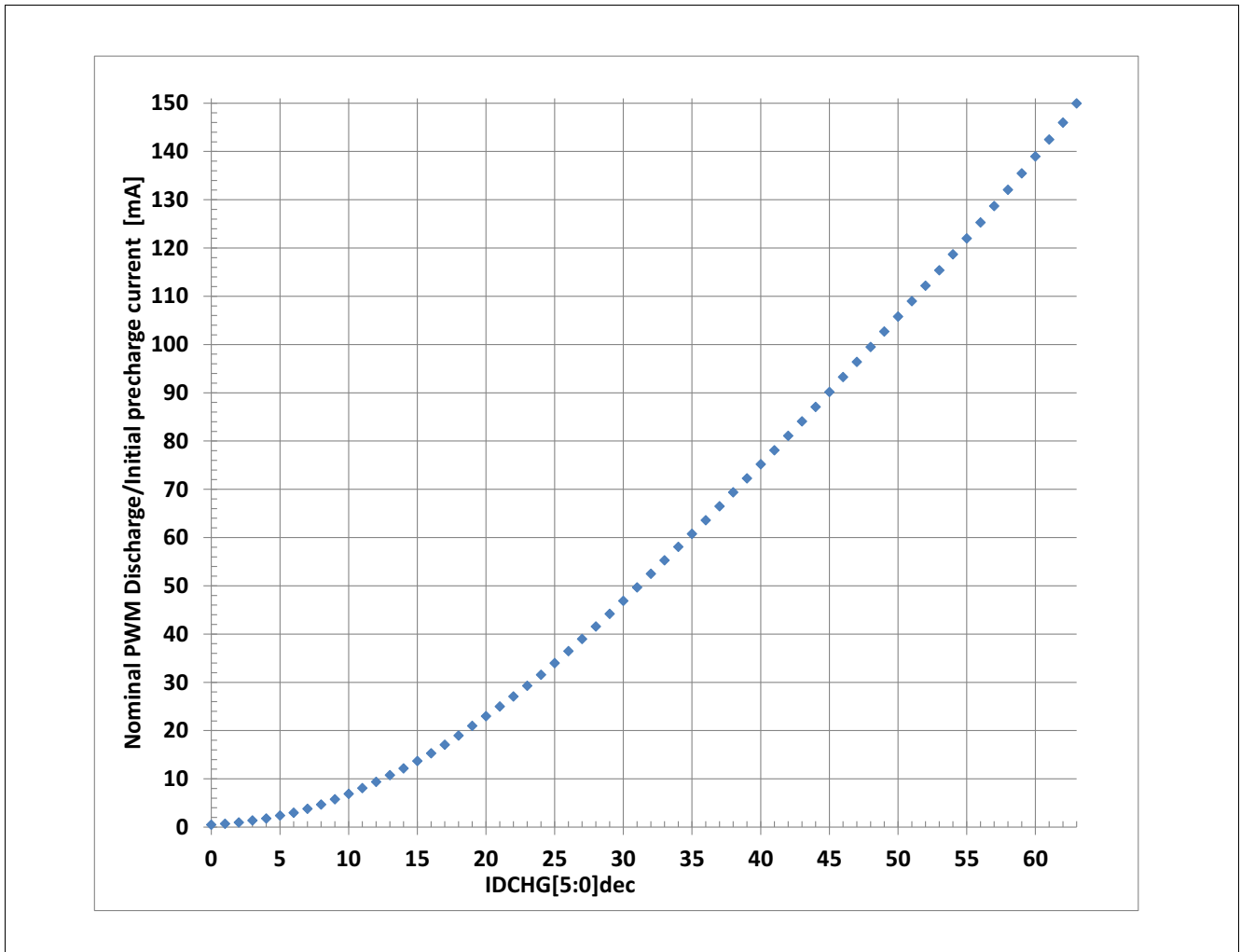

Figure 43 Configurable discharge currents in PWM operation

**Gate Drivers**

**Table 25 Discharge currents and initial pre-discharge currents**

<b>IDCHG[5:0], PDCHGINITx[5:0]</b>	<b>Parameter name</b>	<b>Nom. current [mA]</b>	<b>Max. deviation to nominal values [%]</b>
000000 <sub>B</sub>	$I_{DCHG0}$	0.5	+/- 60%
000001 <sub>B</sub>	$I_{DCHG1}$	0.7	+/- 60 %
000010 <sub>B</sub>	$I_{DCHG2}$	1.0	+/- 60 %
000011 <sub>B</sub>	$I_{DCHG3}$	1.4	+/- 60 %
000100 <sub>B</sub>	$I_{DCHG4}$	1.8	+/- 60 %
000101 <sub>B</sub>	$I_{DCHG5}$	2.4	+/- 60 %
000110 <sub>B</sub>	$I_{DCHG6}$	3.0	+/- 60 %
000111 <sub>B</sub>	$I_{DCHG7}$	3.8	+/- 60 %
001000 <sub>B</sub>	$I_{DCHG8}$	4.7	+/- 60 %
001001 <sub>B</sub>	$I_{DCHG9}$	5.8	+/- 60 %
001010 <sub>B</sub>	$I_{DCHG10}$	6.9	+/- 60 %
001011 <sub>B</sub>	$I_{DCHG11}$	8.1	+/- 60 %
001100 <sub>B</sub>	$I_{DCHG12}$	9.4	+/- 60 %
001101 <sub>B</sub>	$I_{DCHG13}$	10.7	+/- 60 %
001110 <sub>B</sub>	$I_{DCHG14}$	12.1	+/- 40%
001111 <sub>B</sub>	$I_{DCHG15}$	13.5	+/- 40%
010000 <sub>B</sub>	$I_{DCHG16}$	15.1	+/- 40 %
010001 <sub>B</sub>	$I_{DCHG17}$	16.8	+/- 40 %
010010 <sub>B</sub>	$I_{DCHG18}$	18.6	+/- 40%
010011 <sub>B</sub>	$I_{DCHG19}$	20.5	+/- 40 %
010100 <sub>B</sub>	$I_{DCHG20}$	22.5	+/- 40%
010101 <sub>B</sub>	$I_{DCHG21}$	24.5	+/- 40 %
010110 <sub>B</sub>	$I_{DCHG22}$	26.5	+/- 40 %
010111 <sub>B</sub>	$I_{DCHG23}$	28.7	+/- 40 %
011000 <sub>B</sub>	$I_{DCHG24}$	30.9	+/- 40 %
011001 <sub>B</sub>	$I_{DCHG25}$	33.2	+/- 40 %
011010 <sub>B</sub>	$I_{DCHG26}$	35.7	+/- 40 %
011011 <sub>B</sub>	$I_{DCHG27}$	38.2	+/- 40 %
011100 <sub>B</sub>	$I_{DCHG28}$	40.8	+/- 40 %
011101 <sub>B</sub>	$I_{DCHG29}$	43.4	+/- 30 %
011110 <sub>B</sub>	$I_{DCHG30}$	46.1	+/- 30 %
011111 <sub>B</sub>	$I_{DCHG31}$	48.8	+/- 30 %
100000 <sub>B</sub>	$I_{DCHG32}$	51.5	+/- 30 %
100001 <sub>B</sub>	$I_{DCHG33}$	54.2	+/- 30 %
100010 <sub>B</sub>	$I_{DCHG34}$	56.9	+/- 30 %
100011 <sub>B</sub>	$I_{DCHG35}$	59.6	+/- 30 %

**Gate Drivers**

**Table 25 Discharge currents and initial pre-discharge currents (cont'd)**

<b>IDCHG[5:0], PDCHGINITx[5:0]</b>	<b>Parameter name</b>	<b>Nom. current [mA]</b>	<b>Max. deviation to nominal values [%]</b>
100100 <sub>B</sub>	$I_{DCHG36}$	62.4	+/- 30 %
100101 <sub>B</sub>	$I_{DCHG37}$	65.2	+/- 30 %
100110 <sub>B</sub>	$I_{DCHG38}$	68	+/- 30 %
100111 <sub>B</sub>	$I_{DCHG39}$	70.8	+/- 30 %
101000 <sub>B</sub>	$I_{DCHG40}$	73.7	+/- 30 %
101001 <sub>B</sub>	$I_{DCHG41}$	76.6	+/- 30 %
101010 <sub>B</sub>	$I_{DCHG42}$	79.5	+/- 30 %
101011 <sub>B</sub>	$I_{DCHG43}$	82.5	+/- 30 %
101100 <sub>B</sub>	$I_{DCHG44}$	85.5	+/- 30 %
101101 <sub>B</sub>	$I_{DCHG45}$	88.5	+/- 30 %
101110 <sub>B</sub>	$I_{DCHG46}$	91.5	+/- 30 %
101111 <sub>B</sub>	$I_{DCHG47}$	94.6	+/- 30 %
110000 <sub>B</sub>	$I_{DCHG48}$	97.7	+/- 30 %
110001 <sub>B</sub>	$I_{DCHG49}$	100.9	+/- 30 %
110010 <sub>B</sub>	$I_{DCHG50}$	104.2	+/- 30 %
110011 <sub>B</sub>	$I_{DCHG51}$	107.5	+/- 30 %
110100 <sub>B</sub>	$I_{DCHG52}$	110.8	+/- 30 %
110101 <sub>B</sub>	$I_{DCHG53}$	114.2	+/- 30 %
110110 <sub>B</sub>	$I_{DCHG54}$	117.6	+/- 30 %
110111 <sub>B</sub>	$I_{DCHG55}$	121	+/- 30 %
111000 <sub>B</sub>	$I_{DCHG56}$	124.5	+/- 30 %
111001 <sub>B</sub>	$I_{DCHG57}$	128	+/- 30 %
111010 <sub>B</sub>	$I_{DCHG58}$	131.5	+/- 30 %
111011 <sub>B</sub>	$I_{DCHG59}$	135.1	+/- 30 %
111100 <sub>B</sub>	$I_{DCHG60}$	138.7	+/- 30 %
111101 <sub>B</sub>	$I_{DCHG61}$	142.3	+/- 30 %
111110 <sub>B</sub>	$I_{DCHG62}$	145.8	+/- 30 %
111111 <sub>B</sub>	$I_{DCHG63}$	150	+/- 30 %

## 9.4 Passive discharge

Resistors ( $R_{GGND}$ ) between the gate of GHx and GND, and between GLx and GND, ensure that the external MOSFETs are turned off in the following conditions:

- $V_{CC1}$  undervoltage
- HBxMODE = 00<sub>B</sub> in Normal Mode
- **CPEN** = 0 in Normal Mode
- CSA Overcurrent detection with **OCEN** = 1 in normal mode

## Gate Drivers

- VS overvoltage or VSINT overvoltage
- Charge pump undervoltage and charge pump blank time ( $t_{\text{CPUVBLANK}}$ )
- Charge pump overtemperature (**CP\_OT**)
- VDS overvoltage after active discharge in Normal Mode
- In Init Mode, Stop Mode, Fail Safe Mode, Restart Mode and Sleep Mode (exceptions for low-sides in parking braking and VS / VSINT overvoltage braking, refer to [Chapter 9.6](#) and [Chapter 10.9.3](#))

### 9.5 Slam mode

The slam mode is applicable in Normal Mode.

If the SLAM bit is set in **BRAKE** register:

1. If HBxMODE = 01b or 10b, then the corresponding MOSFETs are actively turned off with their static discharge current during their respective tHBxCCP Active.
2. Then charge pump is deactivated independently from **CPEN**
3. Then PWM1/CRC input pin is mapped to LS1, LS2, LS3, independently from PWM\_NB, HBxMODE and HBx\_PWM\_EN
  - a) If PWM1/CRC is High, then the low-side MOSFETs are turned on within  $t_{\text{ON\_BRAKE}}$ .
  - b) If PWM1/CRC is Low, then the low-side MOSFETs are turned off within  $t_{\text{OFF\_BRAKE}}$ .

There is also the possibility to disable selectively the LSx in SLAM mode.

### 9.6 Parking braking mode

If **PARK\_BRK\_EN** bit is set, while the device goes in Sleep Mode or in Stop Mode:

1. If HBxMODE = 01b or 10b, then the corresponding MOSFETs are actively turned off with their static discharge current during their respective tHBxCCP Active.
2. Then charge pump is deactivated independently from CPEN bit.
3. Then the passive discharge ( $R_{\text{GGND}}$ ) of the low-sides is deactivated, the passive discharge of the high-sides are activated
4. If PWM1/CRC is High, then the low-side MOSFETs are turned on within  $t_{\text{ON\_BRAKE}}$ .

Refer to [Chapter 10.9.2](#) for the protection of the of low-side MOSFETs against short circuits when the parking braking mode is activated.



## 9.7 Charge pump

A dual-stage charge pump supplies the gate drivers for the high-side and low-side MOSFETs. It requires three external capacitors connected between CPC1N and CPC1P, CPC2N and CPC2P, VS and CP.

The buffer capacitor between VS and CP must have a capacitance equal or higher than 470 nF.

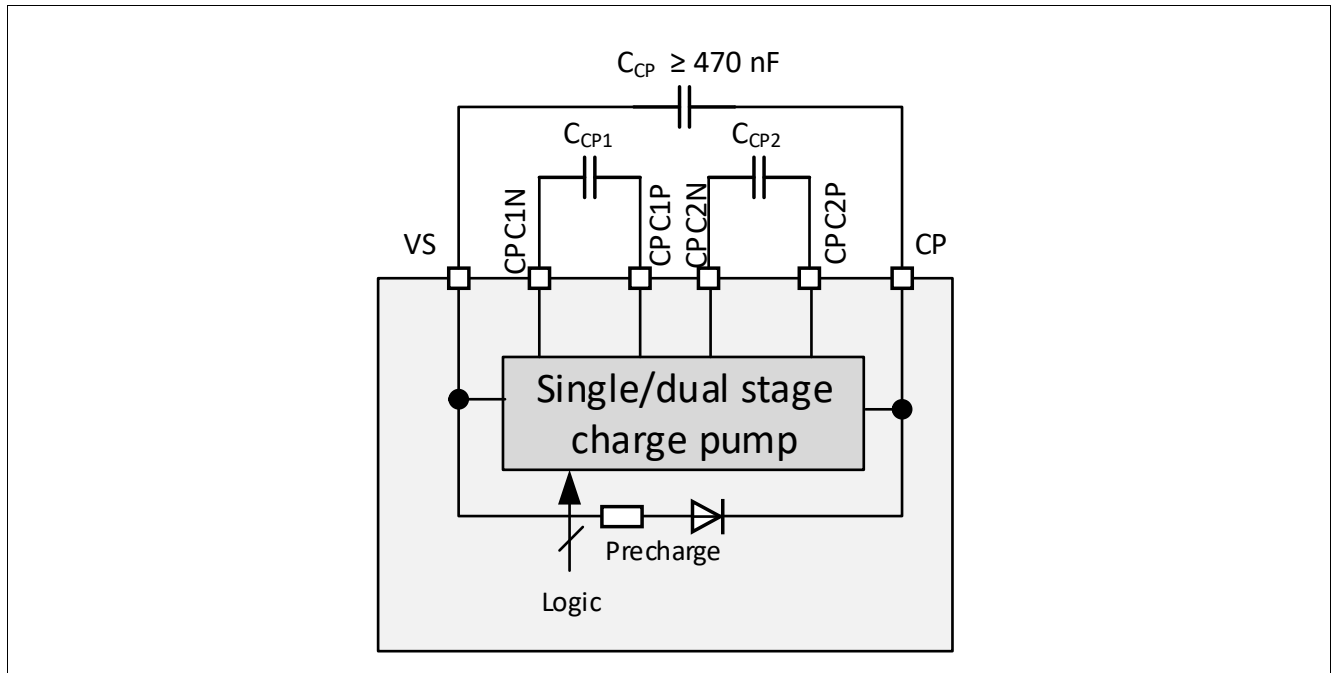

Figure 44 Charge pump - Block diagram

### Logic or normal level MOSFETs

The regulation of the charge pump outputs voltage can be configured depending on the type of MOSFET.

**FET\_LVL = 0:** Logic level MOSFETs are selected:

- $V_{CP} - V_S = V_{CP3}$  (11 V typ. at  $V_S > 8$  V).
- The high-side gate-source voltage  $G_{Hx} - S_{Hx}$  is  $V_{GH4}$  ( $V_S > 8$  V).
- The low-side gate-source voltage  $G_{Lx} - S_{Lx}$  is  $V_{GH3}$  ( $V_S > 8$  V).

**FET\_LVL = 1:** Normal level MOSFETs are selected:

- $V_{CP} - V_S = V_{CP1}$  (15 V typ. at  $V_S > 8$  V).
- The high-side and low-side gate-source voltage  $G_{Hx} - S_{Hx}$  or  $G_{Lx} - S_{Lx}$  is  $V_{GH1}$  ( $V_S > 8$  V).

$CPSTGA = 0$  (default, see **GENCTRL**), the device operates with the dual-stage charge pump.

If  $CPSTGA = 1$ , the device switches to single-stage or dual-stage charge pump automatically:

- If  $V_S > V_{CPSO_{DS}}$ : the TLE9185QXW switches from a dual-stage to a single-stage charge pump.
- If  $V_S < V_{CPSO_{SD}}$ : the TLE9185QXW switches from single-stage to dual-stage charge pump.

The operation with the single-stage charge pump reduces the current consumption from the VS pin.

## **9.8 Frequency modulation**

A modulation of the charge pump frequency can be activated to reduce the peak emission.

The modulation frequency is set by the control bit FMODE in **GENCTRL**:

- FMODE = 0: No modulation.
- FMODE = 1: Modulation frequency = 15.6 kHz (default).

**Gate Drivers**

**9.9 Electrical characteristics gate driver**

The electrical characteristics related to the gate driver are valid for  $V_{CP} > V_S + 8.5\text{ V}$

**Table 26 Electrical characteristics: gate drivers**

$V_{SINT} = 5.5\text{ V to } 28\text{ V}$ ,  $T_j = -40^\circ\text{C to } +175^\circ\text{C}$ ,

$V_{CP} > V_S + 8.5\text{ V}$ ,  $V_S = 6\text{ to } 19\text{ V}$ , all voltages with respect to ground, positive current flowing into pin except for  $I_{GLx}$  and  $I_{GHx}$  (unless otherwise specified).

Parameter	Symbol	Values			Unit	Note or Test Condition	Number
		Min.	Typ.	Max.			
<b>Comparators</b>							
SHx High Threshold	$V_{SHH}$	$V_S - 2.6$	–	$V_S - 1.9$	V		P_12.11.1
SHx Low Threshold	$V_{SHL}$	1.9	–	2.6	V	Referred to GND	P_12.11.2
SHx comparator delay	$t_{SHx}$	–	12	30	ns	<sup>1)</sup>	P_12.11.3
<b>MOSFET Driver Output</b>							
High Level Output Voltage GHx vs. SHx and GLx vs. SL	$V_{GH1}$	10	11.5	12.5	V	<sup>2)</sup> $V_S \geq 8\text{ V}$ , $C_{Load} = 10\text{ nF}$ , $I_{CP} = -12\text{ mA}$ , FET_LVL = 1	P_12.11.4
High Level Output Voltage GHx vs. SHx and GLx vs. SL	$V_{GH2}$	7	–	12.5	V	$V_S = 6\text{ V}$ , $C_{Load} = 10\text{ nF}$ , $I_{CP} = -6\text{ mA}$ , FET_LVL = 1	P_12.11.5
High Level Output Voltage GLx vs. SL	$V_{GH3}$	10	–	12.5	V	<sup>3)</sup> $V_S \geq 6\text{ V}$ , $C_{Load} = 10\text{ nF}$ , FET_LVL = 0	P_12.11.6
High Level Output Voltage GHx vs. SHx	$V_{GH4}$	8.5	10	12.5	V	<sup>2)</sup> $V_S \geq 8\text{ V}$ , $C_{Load} = 10\text{ nF}$ , $I_{CP} = -12\text{ mA}$ , FET_LVL = 0	P_12.11.7
High Level Output Voltage GHx vs. SHx	$V_{GH5}$	7	–	12.5	V	$V_S = 6\text{ V}$ , $C_{LOAD} = 10\text{ nF}$ , $I_{CP} = -6\text{ mA}$ , FET_LVL = 0	P_12.11.8
Charge current	$I_{CHG0}$	-60%	0.5	+60%	mA	$I_{CHG} = 0_D$ <sup>1)</sup> $C_{Load} = 2.2\text{ nF}$ $V_S \geq 8\text{ V}$ , $V_{GS} \leq V_{GS(ON)}$ <sup>4)</sup>	P_12.11.70
Charge current	$I_{CHG8}$	-55%	4.7	+55%	mA	$I_{CHG} = 8_D$ <sup>1)</sup> $C_{Load} = 2.2\text{ nF}$ $V_S \geq 8\text{ V}$ , $V_{GS} \leq V_{GS(ON)}$ <sup>4)</sup>	P_12.11.71
Charge current	$I_{CHG16}$	-40%	15.3	+40%	mA	$I_{CHG} = 16_D$ <sup>1)</sup> $C_{Load} = 2.2\text{ nF}$ $V_S \geq 8\text{ V}$ , $V_{GS} \leq V_{GS(ON)}$ <sup>4)</sup>	P_12.11.72
Charge current	$I_{CHG32}$	-30%	52.5	+30%	mA	$I_{CHG} = 32_D$ <sup>1)</sup> $C_{Load} = 10\text{ nF}$ $V_S \geq 8\text{ V}$ , $V_{GS} \leq V_{GS(ON)}$ <sup>4)</sup>	P_12.11.73

**Gate Drivers**

**Table 26 Electrical characteristics: gate drivers (cont'd)**

$V_{SINT} = 5.5\text{ V to }28\text{ V}$ ,  $T_j = -40^\circ\text{C to }+175^\circ\text{C}$ ,

$V_{CP} > V_S + 8.5\text{ V}$ ,  $V_S = 6\text{ to }19\text{ V}$ , all voltages with respect to ground, positive current flowing into pin except for  $I_{GLX}$  and  $I_{GHX}$  (unless otherwise specified).

Parameter	Symbol	Values			Unit	Note or Test Condition	Number
		Min.	Typ.	Max.			
Charge current	$I_{CHG48}$	-30%	99.5	+30%	mA	$ICHG = 48\text{ D}^{1)}$ $C_{Load} = 10\text{ nF}$ $V_S \geq 8\text{ V}$ , $V_{GS} \leq V_{GS(ON)}^{4)}$	P_12.11.74
Charge current	$I_{CHG63}$	-30%	150	+30%	mA	$ICHG = 63\text{ D}^{1)}$ $C_{Load} = 22\text{ nF}$ $V_S \geq 8\text{ V}$ , $V_{GS} \leq V_{GS(ON)}^{4)}$	P_12.11.75
Discharge current	$I_{DCH0}$	-60%	-0.5	+60%	mA	$IDCHG = 0\text{ D}^{1)}$ $C_{Load} = 2.2\text{ nF}$ $V_S \geq 8\text{ V}$ , $V_{GS} \geq V_{GS(OFF1)}$	P_12.11.76
Discharge current	$I_{DCH8}$	-55%	-4.7	55%	mA	$IDCHG = 8\text{ D}^{1)}$ $C_{Load} = 2.2\text{ nF}$ $V_S \geq 8\text{ V}$ , $V_{GS} \geq V_{GS(OFF1)}$	P_12.11.77
Discharge current	$I_{DCHG16}$	-40%	-15.1	+40%	mA	$IDCHG = 16\text{ D}^{1)}$ $C_{Load} = 2.2\text{ nF}$ $V_S \geq 8\text{ V}$ , $V_{GS} \geq V_{GS(OFF1)}$	P_12.11.78
Discharge current	$I_{DCHG32}$	-30%	-51.5	+30%	mA	$IDCHG = 32\text{ D}^{1)}$ $C_{Load} = 10\text{ nF}$ $V_S \geq 8\text{ V}$ , $V_{GS} \geq V_{GS(OFF2)}$	P_12.11.79
Discharge current	$I_{DCHG48}$	-30%	-97.7	+30%	mA	$IDCHG = 48\text{ D}^{1)}$ $C_{Load} = 10\text{ nF}$ $V_S \geq 8\text{ V}$ , $V_{GS} \geq V_{GS(OFF2)}$	P_12.11.80
Discharge current	$I_{DCHG63}$	-30%	-150	+30%	mA	$IDCHG = 63\text{ D}^{1)}$ $C_{Load} = 22\text{ nF}$ $V_S \geq 8\text{ V}$ , $V_{GS} \geq V_{GS(OFF2)}$	P_12.11.81
Charge current temperature drift	$I_{CHG0,TDrift}$	-37%	-12%	15%		$ICHG = 0\text{ D}^{1)5)}$	P_12.11.119
Charge current temperature drift	$I_{CHG8,TDrift}$	-17%	1%	20%		$ICHG = 8\text{ D}^{1)5)}$	P_12.11.120
Charge current temperature drift	$I_{CHG16,TDrift}$	-12%	3%	18%		$ICHG = 16\text{ D}^{1)5)}$	P_12.11.121
Charge current temperature drift	$I_{CHG32,TDrift}$	-11%	-1%	9%		$ICHG = 32\text{ D}^{1)5)}$	P_12.11.122
Charge current temperature drift	$I_{CHG48,TDrift}$	-7.5%	0.5%	8%		$ICHG = 48\text{ D}^{1)5)}$	P_12.11.123
Charge current temperature drift	$I_{CHG63,TDrift}$	-5.5%	1.5%	8.5%		$IDCHG = 63\text{ D}^{1)5)}$	P_12.11.124
Discharge current temperature drift	$I_{DCHG0,TDrift}$	-29%	-4.5%	20%		$IDCHG = 0\text{ D}^{1)5)}$	P_12.11.125

**Gate Drivers**

**Table 26 Electrical characteristics: gate drivers (cont'd)**

$V_{SINT} = 5.5\text{ V to } 28\text{ V}$ ,  $T_j = -40^\circ\text{C to } +175^\circ\text{C}$ ,

$V_{CP} > V_S + 8.5\text{ V}$ ,  $V_S = 6\text{ to } 19\text{ V}$ , all voltages with respect to ground, positive current flowing into pin except for  $I_{GLx}$  and  $I_{GHx}$  (unless otherwise specified).

Parameter	Symbol	Values			Unit	Note or Test Condition	Number
		Min.	Typ.	Max.			
Discharge current temperature drift	$I_{DCHG8,TDrift}$	-8%	8.5%	26%		IDCHG = $8_D^{1)5)}$	P_12.11.126
Discharge current temperature drift	$I_{DCHG16,TDrift}$	-4%	9.5%	23%		IDCHG = $16_D^{1)5)}$	P_12.11.127
Discharge current temperature drift	$I_{DCHG32,TDrift}$	-4%	4.5%	13%		IDCHG = $32_D^{1)5)}$	P_12.11.128
Discharge current temperature drift	$I_{DCHG48,TDrift}$	-4%	3.5%	10%		IDCHG = $48_D^{1)5)}$	P_12.11.129
Discharge current temperature drift	$I_{DCHG63,TDrift}$	-3.5%	3.5%	9.5%		IDCHG = $63_D^{1)5)}$	P_12.11.130
Charge current $V_S$ drift	$I_{CHG0,VsDrift}$	3%	4.5%	6%		ICHG = $0_D^{1)6)}$	P_12.11.131
Charge current $V_S$ drift	$I_{CHG8,VsDrift}$	4.5%	6%	7.5%		ICHG = $8_D^{1)6)}$	P_12.11.132
Charge current $V_S$ drift	$I_{CHG16,VsDrift}$	4%	5.8%	7.5%		ICHG = $16_D^{1)6)}$	P_12.11.133
Charge current $V_S$ drift	$I_{CHG32,VsDrift}$	2%	3.8%	5.8%		ICHG = $32_D^{1)6)}$	P_12.11.134
Charge current $V_S$ drift	$I_{CHG48,VsDrift}$	-0.5%	2%	4.5%		ICHG = $48_D^{1)6)}$	P_12.11.135
Charge current $V_S$ drift	$I_{CHG63,VsDrift}$	-2.3%	0.3%	2.8%		ICHG = $63_D^{1)6)}$	P_12.11.136
Discharge current $V_S$ drift	$I_{DCHG0,VsDrift}$	-3%	-1.5%	0%		IDCHG = $0_D^{1)6)}$	P_12.11.137
Discharge current $V_S$ drift	$I_{DCHG8,VsDrift}$	-3%	-0.5%	2%		IDCHG = $8_D^{1)6)}$	P_12.11.138
Discharge current $V_S$ drift	$I_{DCHG16,VsDrift}$	-3.3%	-0.3%	2.3%		IDCHG = $16_D^{1)6)}$	P_12.11.139
Discharge current $V_S$ drift	$I_{DCHG32,VsDrift}$	-2%	0%	2%		IDCHG = $32_D^{1)6)}$	P_12.11.140
Discharge current $V_S$ drift	$I_{DCHG48,VsDrift}$	-1.5%	0%	1.5%		IDCHG = $48_D^{1)6)}$	P_12.11.141
Discharge current $V_S$ drift	$I_{DCHG63,VsDrift}$	-1.5%	0.2%	1.5%		IDCHG = $63_D^{1)6)}$	P_12.11.142
Passive discharge resistance between GHx/GLx and GND	$R_{GGND}$	10	20	30	k $\Omega$	<sup>1)</sup>	P_12.11.22
Resistor between SHx and GND	$R_{SHGND}$	10	20	30	k $\Omega$	<sup>1)7)</sup>	P_12.11.23
Low R <sub>DS(on)</sub> mode	$R_{ONCCP}$	–	22	35	$\Omega$	<sup>1)</sup> $V_S = 13.5\text{ V}$ $V_{CP} = V_S + 14\text{ V}$  $I_{CHG} = I_{DCHG} = 63_D$	P_12.11.24

**Gate Drivers**

**Table 26 Electrical characteristics: gate drivers (cont'd)**

$V_{SINT} = 5.5\text{ V to }28\text{ V}$ ,  $T_j = -40^\circ\text{C to }+175^\circ\text{C}$ ,

$V_{CP} > V_S + 8.5\text{ V}$ ,  $V_S = 6\text{ to }19\text{ V}$ , all voltages with respect to ground, positive current flowing into pin except for  $I_{GLX}$  and  $I_{GHX}$  (unless otherwise specified).

Parameter	Symbol	Values			Unit	Note or Test Condition	Number
		Min.	Typ.	Max.			
<b>Gate Drivers Dynamic Parameters</b>							
Gate Driver turn-on delay Time	$t_{DGDRV\_ON1}$	–	–	400	ns	<sup>8)</sup> From PWM <sup>9)</sup> rising edge to 20% of $I_{CHGx}$ , $x = 0$ to 63, $C_{Load} = 10\text{ nF}$ , <b>BDFREQ</b> = 0	P_12.11.25
Gate Driver turn-on delay Time	$t_{DGDRV\_ON2}$	–	–	300	ns	<sup>8)</sup> From PWM <sup>9)</sup> rising edge to 20% of $I_{CHGx}$ , $x = 0$ to 63, $C_{Load} = 10\text{ nF}$ , <b>BDFREQ</b> = 1	P_12.11.93
Gate Driver current turn-on rise time	$t_{GDRV\_RISE(ON)}$	–	30	50	ns	<sup>8)</sup> From 20% of $I_{CHGx}$ to $I_{CHGx}$ , $x = 0$ to 63, $C_{Load} = 10\text{ nF}$	P_12.11.26
Gate Driver turn-off delay Time	$t_{DGDRV\_OFF1}$	–	–	400	ns	<sup>8)</sup> From PWM <sup>9)</sup> rising edge to 20% of $I_{DCHGx}$ , $x = 0$ to 63, $C_{Load} = 10\text{ nF}$ , <b>BDFREQ</b> = 0	P_12.11.27
Gate Driver turn-off delay Time	$t_{DGDRV\_OFF2}$	–	–	300	ns	<sup>8)</sup> From PWM <sup>9)</sup> rising edge to 20% of $I_{DCHGx}$ , $x = 0$ to 63, $C_{Load} = 10\text{ nF}$ , <b>BDFREQ</b> = 1	P_12.11.94
Gate Driver current turn-off rise time	$t_{GDRV\_RISE(OFF)}$	–	30	50	ns	<sup>8)</sup> From 20% of $I_{DCHGx}$ to $I_{DCHGx}$ , $x = 0$ to 63, $C_{Load} = 10\text{ nF}$	P_12.11.28
External MOSFET gate-to-source voltage - ON	$V_{GS(ON)1}$	7	–	–	V	<sup>1)</sup> $V_S \geq 8\text{ V}$ , <b>FET_LVL</b> =1	P_12.11.29
External MOSFET gate-to-source voltage - ON	$V_{GS(ON)1}$	7	–	–	V	<sup>1)</sup> $V_S \geq 8\text{ V}$ , <b>FET_LVL</b> =1	P_12.11.102
External MOSFET gate-to-source voltage - ON	$V_{GS(ON)2}$	5.5	–	–	V	<sup>1)</sup> $V_S \geq 8\text{ V}$ , <b>FET_LVL</b> =0	P_12.11.103

**Gate Drivers**

**Table 26 Electrical characteristics: gate drivers (cont'd)**

$V_{SINT} = 5.5\text{ V to }28\text{ V}$ ,  $T_j = -40^\circ\text{C to }+175^\circ\text{C}$ ,

$V_{CP} > V_S + 8.5\text{ V}$ ,  $V_S = 6\text{ to }19\text{ V}$ , all voltages with respect to ground, positive current flowing into pin except for  $I_{GLX}$  and  $I_{GHX}$  (unless otherwise specified).

Parameter	Symbol	Values			Unit	Note or Test Condition	Number
		Min.	Typ.	Max.			
External MOSFET gate-to-source voltage - OFF	$V_{GS(OFF)1}$	–	–	1.5	V	<sup>1)</sup> $IDCHGx \leq 28_D(\leq 41\text{ mA typ.})$	P_12.11.30
External MOSFET gate-to-source voltage - OFF	$V_{GS(OFF)2}$	–	–	5	V	<sup>1)</sup> $IDCHGx > 28_D(> 41\text{ mA typ.})$	P_12.11.101
PWM synchronization delay	$t_{PWM\_SYNCH0}$	80	–	200	ns	<sup>1)</sup> <b>BDFREQ</b> = 0	P_12.11.33
PWM synchronization delay	$t_{PWM\_SYNCH1}$	40	–	100	ns	<sup>1)</sup> <b>BDFREQ</b> = 1	P_12.11.82
Bridge driver frequency	$t_{BDFREQ0}$	16.8	18.75	20.7	MHz	<sup>1)</sup> <b>BDFREQ</b> = 0	P_12.11.83
Bridge driver frequency	$t_{BDFREQ1}$	33.7	37.5	42.3	MHz	<sup>1)</sup> <b>BDFREQ</b> = 1	P_12.11.84
Pre-charge time	$t_{PCHG000}$	80	107	140	ns	<sup>1)</sup> $TPCHG = 000$ , <b>BDFREQ</b> = 0 or 1	P_12.11.34
Pre-charge time	$t_{PCHG001}$	130	160	190	ns	<sup>1)</sup> $TPCHG = 001$ , <b>BDFREQ</b> = 0 or 1	P_12.11.35
Pre-charge time	$t_{PCHG010}$	170	214	260	ns	<sup>1)</sup> $TPCHG = 010$ , <b>BDFREQ</b> = 0 or 1	P_12.11.36
Pre-charge time	$t_{PCHG011}$	210	267	330	ns	<sup>1)</sup> $TPCHG = 011$ , <b>BDFREQ</b> = 0 or 1	P_12.11.37
Pre-charge time	$t_{PCHG100}$	250	320	390	ns	<sup>1)</sup> $TPCHG = 100$ , <b>BDFREQ</b> = 0 or 1	P_12.11.85
Pre-charge time	$t_{PCHG101}$	420	533	630	ns	<sup>1)</sup> $TPCHG = 101$ , <b>BDFREQ</b> = 0 or 1	P_12.11.86
Pre-charge time	$t_{PCHG110}$	600	747	900	ns	<sup>1)</sup> $TPCHG = 110$ , <b>BDFREQ</b> = 0 or 1	P_12.11.87
Pre-charge time	$t_{PCHG111}$	840	1067	1260	ns	<sup>1)</sup> $TPCHG = 111$ , <b>BDFREQ</b> = 0 or 1	P_12.11.88
Pre-discharge time	$t_{PDCHG000}$	80	107	140	ns	<sup>1)</sup> $TPDCHG = 000$ , <b>BDFREQ</b> = 0 or 1	P_12.11.38
Pre-discharge time	$t_{PDCHG001}$	130	160	190	ns	<sup>1)</sup> $TPDCHG = 001$ , <b>BDFREQ</b> = 0 or 1	P_12.11.39
Pre-discharge time	$t_{PDCHG010}$	170	214	260	ns	<sup>1)</sup> $TPDCHG = 010$ , <b>BDFREQ</b> = 0 or 1	P_12.11.40
Pre-discharge time	$t_{PDCHG011}$	210	267	330	ns	<sup>1)</sup> $TPDCHG = 011$ , <b>BDFREQ</b> = 0 or 1	P_12.11.41
Pre-discharge time	$t_{PDCHG100}$	250	320	390	ns	<sup>1)</sup> $TPDCHG = 100$ , <b>BDFREQ</b> = 0 or 1	P_12.11.89
Pre-discharge time	$t_{PDCHG101}$	420	533	630	ns	<sup>1)</sup> $TPDCHG = 101$ , <b>BDFREQ</b> = 0 or 1	P_12.11.90

**Gate Drivers**

**Table 26 Electrical characteristics: gate drivers (cont'd)**

$V_{SINT} = 5.5\text{ V to } 28\text{ V}$ ,  $T_j = -40^\circ\text{C to } +175^\circ\text{C}$ ,

$V_{CP} > V_S + 8.5\text{ V}$ ,  $V_S = 6\text{ to } 19\text{ V}$ , all voltages with respect to ground, positive current flowing into pin except for  $I_{GLX}$  and  $I_{GHX}$  (unless otherwise specified).

Parameter	Symbol	Values			Unit	Note or Test Condition	Number
		Min.	Typ.	Max.			
Pre-discharge time	$t_{PDCHG110}$	600	747	900	ns	<sup>1)</sup> TPDCHG = 110, BDFREQ = 0 or 1	P_12.11.91
Pre-discharge time	$t_{PDCHG111}$	840	1067	1260	ns	<sup>1)</sup> TPDCHG = 111, BDFREQ = 0 or 1	P_12.11.92
Discharge timeout	$t_{OFF\_TIMEOUT}$	3.2	4	4.8	$\mu\text{s}$	<sup>1)</sup> PWM_NB = 1 <sub>B</sub>	P_12.11.9
<b>Low-side gate driver, CP off - Slam mode, parking braking and VS overvoltage braking</b>							
LS turn-on time, CP off	$t_{ON\_BRAKE}$	-	4.5	9	$\mu\text{s}$	$C_{LOAD} = 10\text{ nF}$ $V_{GLX-VSL} = 5\text{ V}$ , $V_S > 8\text{ V}$ or $V_{SINT} > 8\text{ V}$	P_12.11.42
LS turn-off time, CP off	$t_{OFF\_BRAKE}$	-	0.7	2	$\mu\text{s}$	$C_{LOAD} = 10\text{ nF}$ $V_{GLX-VSL} = 1.5\text{ V}$ , $V_S > 8\text{ V}$ or $V_{SINT} > 8\text{ V}$	P_12.11.43
High output voltage GLX - SL	$V_{GLX\_BRAKE}$	5	-	10	V	$V_S > 8\text{ V}$ or $V_{SINT} > 8\text{ V}$	P_12.11.48
<b>Charge pump</b>							
Charge Pump Frequency	$f_{CP}$	-	250	-	kHz	<sup>1)</sup>	P_12.11.49
Output Voltage VCP vs. VS	$V_{CPmin1}$	8.5	-	-	V	$V_S = 6\text{ V}$ , $I_{CP} = -6\text{ mA}$ , FET_LVL = 1	P_12.11.50
Output Voltage VCP vs. VS	$V_{CPmin2}$	7.5	-	-	V	$V_S = 6\text{ V}$ , $I_{CP} = -6\text{ mA}$ , FET_LVL = 0	P_12.11.51
Regulated CP output voltage, VCP vs. VS	$V_{CP1}$	12	15	17	V	$8\text{ V} < V_S < 23\text{ V}$ $I_{CP} = -12\text{ mA}^{11)}$ , CPSTGA = 0, FET_LVL = 1	P_12.11.52
Regulated CP output voltage, VCP vs. VS	$V_{CP2}$	12	15	17	V	$18\text{ V} < V_S < 23\text{ V}$ $I_{CP} = -12\text{ mA}^{11)}$ , CPSTGA = 1, FET_LVL = 1	P_12.11.53
Regulated CP output voltage, VCP vs. VS	$V_{CP3}$	7.5	11	13	V	$8\text{ V} < V_S < 23\text{ V}$ $I_{CP} = -12\text{ mA}^{11)}$ , CPSTGA = 0, FET_LVL = 0	P_12.11.54
Regulated CP output voltage, VCP vs. VS	$V_{CP4}$	7.5	11	13	V	$13\text{ V} < V_S < 23\text{ V}$ $I_{CP} = -12\text{ mA}^{11)}$ , CPSTGA = 0, FET_LVL = 0	P_12.11.55



**Gate Drivers**

**Table 26 Electrical characteristics: gate drivers (cont'd)**

$V_{SINT} = 5.5\text{ V to } 28\text{ V}$ ,  $T_j = -40^\circ\text{C to } +175^\circ\text{C}$ ,

$V_{CP} > V_S + 8.5\text{ V}$ ,  $V_S = 6\text{ to } 19\text{ V}$ , all voltages with respect to ground, positive current flowing into pin except for  $I_{GLX}$  and  $I_{GHX}$  (unless otherwise specified).

Parameter	Symbol	Values			Unit	Note or Test Condition	Number
		Min.	Typ.	Max.			
Turn-on time	$t_{ON\_VCP1}$	5	–	60	$\mu\text{s}$	<sup>1)10)11)</sup> $18\text{ V} < V_S < 23\text{ V}$ (25%), $I_{CP} = 0$ , CPSTGA = 1, FET_LVL = 1	P_12.11.56
Rise time	$t_{RISE\_VCP1}$	5	30	60	$\mu\text{s}$	<sup>1)10)11)</sup> $18\text{ V} < V_S < 23\text{ V}$ (25%-75%) $I_{CP} = 0$ , CPSTGA = 1, FET_LVL = 1	P_12.11.57
Turn-on time	$t_{ON\_VCP2}$	20	60	120	$\mu\text{s}$	<sup>1)10)11)</sup> $13\text{ V} < V_S < 23\text{ V}$ (25%), $I_{CP} = 0$ , CPSTGA = 1, FET_LVL = 0	P_12.11.58
Rise time	$t_{RISE\_VCP2}$	5	30	60	$\mu\text{s}$	<sup>1)10)11)</sup> $13\text{ V} < V_S < 23\text{ V}$ (25%-75%) $I_{CP} = 0$ , CPSTGA = 1, FET_LVL = 0	P_12.11.59
Automatic switch over dual to single stage charge pump	$V_{CPSO\_DS}$	16	17	18	V	CPSTGA = 1, FET_LVL = 1, VS rising	P_12.11.60
Automatic switch over dual to single stage charge pump	$V_{CPSO\_DS}$	11.5	12.25	13	V	CPSTGA = 1, FET_LVL = 0, VS rising	P_12.11.61
Automatic switch over single to dual stage charge pump	$V_{CPSO\_SD}$	15.5	16.5	17.5	V	CPSTGA = 1, FET_LVL = 1, VS falling	P_12.11.62
Automatic switch over single to dual stage charge pump	$V_{CPSO\_SD}$	11	11.75	12.5	V	CPSTGA = 1, FET_LVL = 0, VS falling	P_12.11.64
Charge pump switch over hysteresis	$V_{CPSO\_HY}$	–	0.5	–	V	<sup>1)</sup> CPSTGA = 1 $V_{CPSO\_DS} - V_{CPSO\_SD}$	P_12.11.65
Charge pump minimum output current	$I_{CPOC1}$	–	–	-12	mA	<sup>11)</sup> $8\text{ V} < V_S < 28\text{ V}$ CPSTGA = 0 FET_LVL = 1	P_12.11.68
Charge pump minimum output current	$I_{CPOC2}$	–	–	-12	mA	<sup>11)</sup> $8\text{ V} < V_S < 28\text{ V}$ CPSTGA = 0 FET_LVL = 0	P_12.11.69

**Gate Drivers**

**Table 26 Electrical characteristics: gate drivers (cont'd)**

$V_{SINT} = 5.5\text{ V to } 28\text{ V}$ ,  $T_j = -40^\circ\text{C to } +175^\circ\text{C}$ ,

$V_{CP} > V_S + 8.5\text{ V}$ ,  $V_S = 6\text{ to } 19\text{ V}$ , all voltages with respect to ground, positive current flowing into pin except for  $I_{GLX}$  and  $I_{GHx}$  (unless otherwise specified).

Parameter	Symbol	Values			Unit	Note or Test Condition	Number
		Min.	Typ.	Max.			
<b>Digital PWMx Inputs</b>							
High Level Input Voltage Threshold	$V_{PVMH}$	–	–	$0.7 \times V_{CC1}$	V	–	P_12.11.95
Low Level Input Voltage Threshold	$V_{PVM L}$	$0.3 \times V_{CC1}$	–	–	V	–	P_12.11.96
PWMx Input Hysteresis	$V_{PVM,hys}$	–	$0.12 \times V_{CC1}$	–	V	1)	P_12.11.97
PWMx Pull-down Resistance	$R_{PD\_PWM}$	20	40	80	k $\Omega$	–	P_12.11.98
<b>CRC Select; Pin PWM1/CRC</b>							
Config Pull-up Resistance	$R_{CFG}$		100		k $\Omega$	12)	P_12.11.99
Config Select Filter Time	$t_{CFG\_F}$	5	10	14	$\mu\text{s}$	1)	P_12.11.105

1) Not subject to production test, specified by design.

2) Independent from **CPSTGA**.

3)  $ICP = -12\text{ mA}$  for  $V_S \geq 8\text{ V}$ ,  $ICP = 6\text{ mA}$  for  $V_S = 6\text{ V}$ .

4)  $V_{GS(ON)} = V_{GS(ON)1}$  if **FET\_LVL** = 1,  $V_{GS(ON)} = V_{GS(ON)2}$  if **FET\_LVL** = 0.

5)  $T_j$  reference =  $25^\circ\text{C}$

6) Valid for  $V_S = 8\text{ to } 19\text{ V}$ ,  $V_S$  reference =  $13.5\text{ V}$

7) This resistance is the resistance between GHx and GND connected through a diode to SHx. As a consequence, the voltage at SHx can rise up to  $0.6\text{ V typ.}$  before it is discharged through the resistor.

8) Not subject to production test, specified by design.

9) External PWM signal.

10) Parameter dependent on the capacitance  $C_{CP}$ .

11)  $C_{CPC1} = C_{CPC2} = 220\text{ nF}$ ,  $C_{CP} = 470\text{ nF}$ . Other  $C_{CP}$  values higher than  $470\text{ nF}$  can be used. Note that this capacitor influences the charge pump rise and turn-on times, and the charge,  $V_{CP}$  ripple voltage when charging the gate of a MOSFET.

12) Config Pull-up will be only active during startup-phase for checking external pull-down. After checking, the typ.  $40\text{ k}\Omega$  Pull-down resistance will be present.

## 10 Supervision Functions

### 10.1 Reset Function

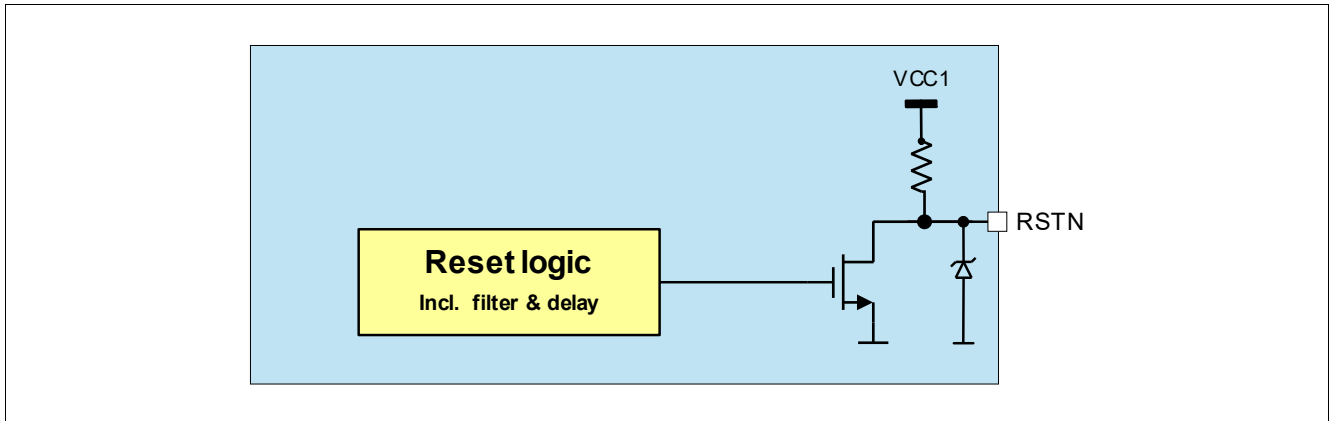

Figure 45 Reset Block Diagram

#### 10.1.1 Reset Output Description

The reset output pin RSTN provides a reset information to the microcontroller, for example, in the event that the output voltage has fallen below the undervoltage threshold  $V_{RTX}$ . In case of a reset event, the reset output RSTN is pulled to low after the filter time  $t_{RF}$  and stays low as long as the reset event is present plus a reset delay time  $t_{RD1}$  or  $t_{RD2}$  depending on the value in **RSTN\_DEL**. When connecting the device to battery voltage, the reset signal remains low initially. When the output voltage VCC1 has reached the reset default threshold  $V_{RT1,r}$  the reset output RSTN is released to high after the reset delay time  $t_{RD1}$ . A reset can also occur due to a watchdog trigger failure. The reset threshold can be adjusted via SPI, the default reset threshold is  $V_{RT1,f}$ . The RSTN pin has an integrated pull-up resistor. In case reset is triggered, it will be pulled low for  $VCC1 \geq 1V$  and for  $VSINT \geq V_{POR,f}$  (see also [Chapter 10.3](#)).

The timings for the RSTN triggering regarding VCC1 undervoltage and watchdog trigger is shown in [Figure 46](#).

Supervision Functions

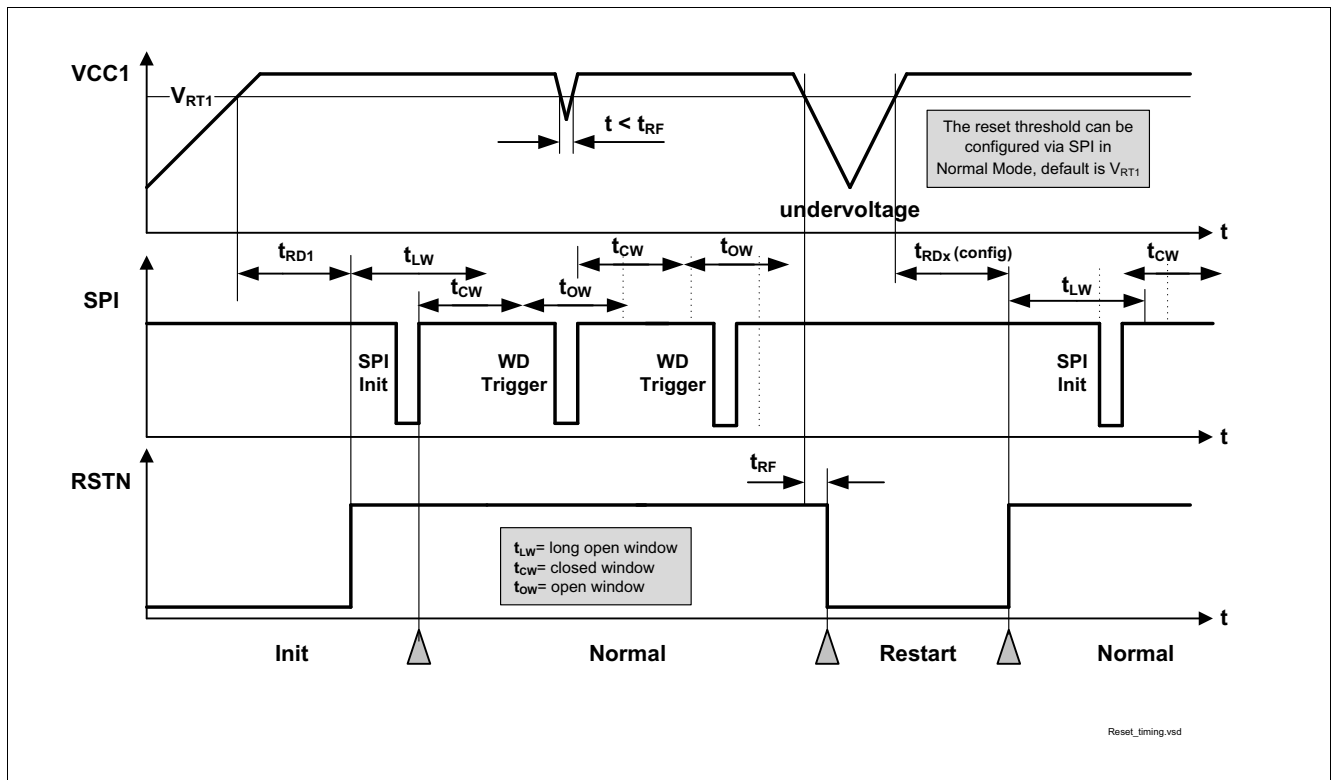

Figure 46 Reset Timing Diagram

### 10.1.2 Soft Reset Description

In Normal Mode and Stop Mode, it is also possible to trigger a device internal reset via a SPI command in order to bring the device into a defined state in case of failures. In this case the microcontroller must send a SPI command and set the **MODE** bits to '11' in the **M\_S\_CTRL** register. As soon as this command becomes valid, the device is set back to Init Mode and all SPI registers are set to their default values (see SPI [Chapter 11.5.1](#) and [Chapter 11.6.1](#)).

Two different soft reset configurations are possible via the SPI bit **SOFT\_RESET\_RO**:

- **SOFT\_RESET\_RO** = '0': The reset output (RSTN) is triggered when the soft reset is executed (default setting) The configured reset delay time **t<sub>RD1</sub>** or **t<sub>RD2</sub>** is applied depending on the value in **RSTN\_DEL**.
- **SOFT\_RESET\_RO** = '1': The reset output (RSTN) is not triggered when the soft reset is executed.

*Note:* The device must be in Normal Mode or Stop Mode when sending this command. Otherwise, the command will be ignored.

*Note:* Allow CRC configuration after software-reset - or better check once again via SPI after software reset.

**Supervision Functions**

**10.2 Watchdog Function**

The watchdog is used to monitor the communication with the microcontroller and to trigger a reset or move the device to Fail Safe Mode, if the microcontroller stops serving the watchdog.

Two different types of watchdog functions are implemented and can be selected via the bit **WD\_CFG**:

- Time-Out Watchdog (default value)
- Window Watchdog

The respective watchdog functions can be selected and programmed in Normal Mode. The configuration stays unchanged in Stop Mode.

Please refer to **Table 27** to match the device modes with the respective watchdog modes.

**Table 27 Watchdog Functionality by modes**

Mode	Watchdog Mode	Remarks
Init Mode	Starts with Long Open Window	Watchdog starts with Long Open Window after RSTN is released.
Normal Mode	WD Programmable	Window Watchdog, Time-Out watchdog or switched off for Stop Mode.
Stop Mode	Watchdog is fixed or off	
Sleep Mode	Off	Device will start with Long Open Window when entering Normal Mode.
Restart Mode	Off	Device will start with Long Open Window when entering Normal Mode.

The watchdog timing is programmed via SPI command in the register **WD\_CTRL**. As soon as the watchdog is programmed, the timer starts with the new setting and the watchdog must be served. The watchdog is triggered by sending a valid SPI-write command to the watchdog configuration register. The watchdog trigger command is executed when the SPI command is interpreted.

When coming from Init Mode, Restart Mode or in certain cases from Stop Mode, the watchdog timer is always started with a long open window. The long open window ( $t_{LW}$ ) allows the microcontroller to run its initialization sequences and then to trigger the watchdog via SPI.

The watchdog timer period can be selected via SPI (**WD\_TIMER**).The timer setting is valid for both watchdog types.

The following watchdog timer periods are available:

- WD Setting 1: 10 ms
- WD Setting 2: 20 ms
- WD Setting 3: 50 ms
- WD Setting 4: 100 ms
- WD Setting 5: 200 ms
- WD Setting 6: 500 ms
- WD Setting 7: 1 s
- WD Setting 8: 10 s

In case of a reset, Restart Mode or Fail-Safe Mode is entered according to the configuration and the SPI bits **WD\_FAIL** are set. Once the RSTN goes high again the watchdog immediately starts with a long open window the device enters automatically Normal Mode.

The Watchdog behaviour in Software Development Mode is described in **Chapter 5.4.7**.

## Supervision Functions

In case a watchdog-trigger was missed in Software Development Mode, the watchdog will start with the long-open-window once again.

The **WD\_FAIL** bits will be set after a watchdog trigger failure.

The **WD\_FAIL** bits are cleared automatically when following conditions apply:

- After a successful watchdog trigger.
- When the watchdog is off: in Stop Mode after successfully disabling it, in Sleep Mode, or in Fail-Safe Mode (except for a watchdog failure).

### 10.2.1 Time-Out Watchdog

The time-out watchdog is an easier and less secure watchdog than a window watchdog as the watchdog trigger can be done at any time within the configured watchdog timer period.

A correct watchdog service immediately results in starting a new watchdog timer period. Taking the tolerances of the internal oscillator into account leads to the safe trigger area as defined in **Figure 47**.

If the time-out watchdog period elapses, a watchdog reset is created by setting the reset output RSTN low and the device switches to Restart Mode or Fail-Safe Mode.

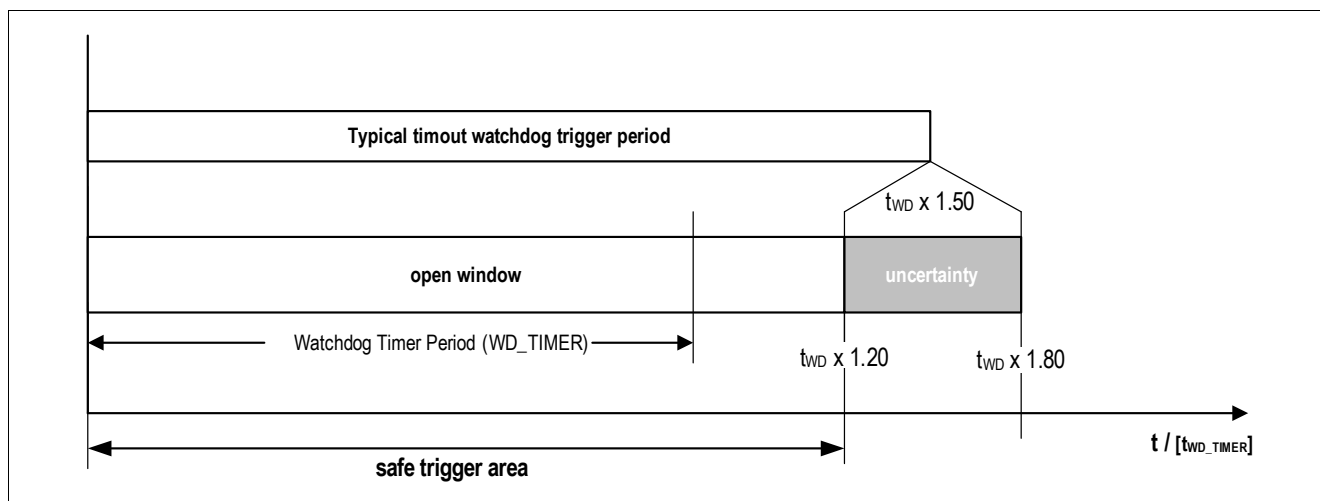

**Figure 47** Time-out Watchdog Definitions

## Supervision Functions

### 10.2.2 Window Watchdog

Compared to the time-out watchdog the characteristic of the window watchdog is that the watchdog timer period is divided between a closed and an open window. The watchdog must be triggered within the open window.

A correct watchdog trigger results in starting the window watchdog period by a closed window followed by an open window.

The watchdog timer period is at the same time the typical trigger time and defines the middle of the open window. Taking the oscillator tolerances into account leads to a safe trigger area of:

$$t_{WD} \times 0.72 < \text{safe trigger area} < t_{WD} \times 1.20.$$

The typical closed window is defined to a width of 60% of the selected window watchdog timer period. Taking the tolerances of the internal oscillator into account leads to the timings as defined in **Figure 48**.

A correct watchdog service immediately results in starting the next closed window.

If the trigger signal meet the closed window or if the watchdog timer period elapses, then a watchdog reset is triggered (RSTN low) and the device switches to Restart Mode or Fail-Safe Mode.

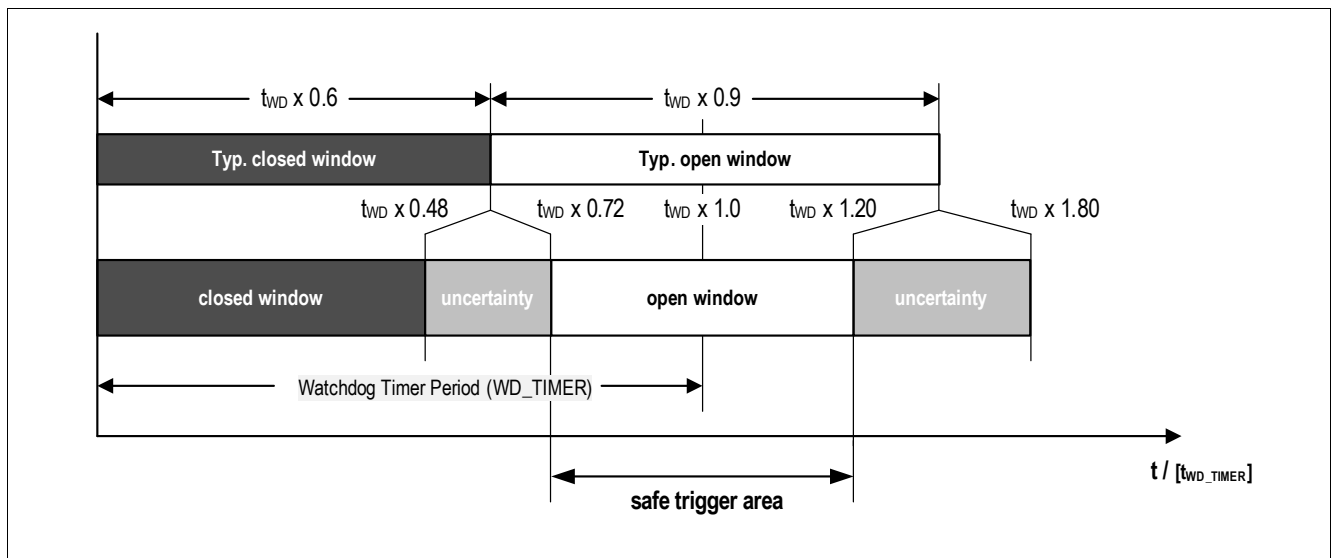

**Figure 48 Window Watchdog Definitions**

### 10.2.3 Watchdog Setting Check Sum

A check sum bit is part of the SPI command to trigger the watchdog and to set the watchdog setting.

The sum of the 16 data bits in the register **WD\_CTRL** needs to have even parity (see **Equation (10.1)**). This is realized by either setting the bit **CHECKSUM** to 0 or 1. If the check sum is wrong, then the SPI command is ignored, i.e. the watchdog is not triggered or the settings are not changed and the bit **SPI\_FAIL** is set.

The written value of the reserved bits of the **WD\_CTRL** register is considered (even if read as '0' in the SPI output) for checksum calculation, i.e. if a 1 is written on the reserved bit position, then a 1 will be used in the checksum calculation.

(10.1)

$$\text{Bit}(\text{CHECKSUM}) = \text{Bit}22 \oplus \dots \oplus \text{Bit}8$$

### 10.2.4 Watchdog during Stop Mode

The watchdog can be disabled for Stop Mode in Normal Mode. For safety reasons, there is a special sequence to be followed in order to disable the watchdog as described in **Figure 49**. Two different SPI bits (**WD\_STM\_EN\_0**, **WD\_STM\_EN\_1**) in the registers **HW\_CTRL** and **WD\_CTRL** need to be set.

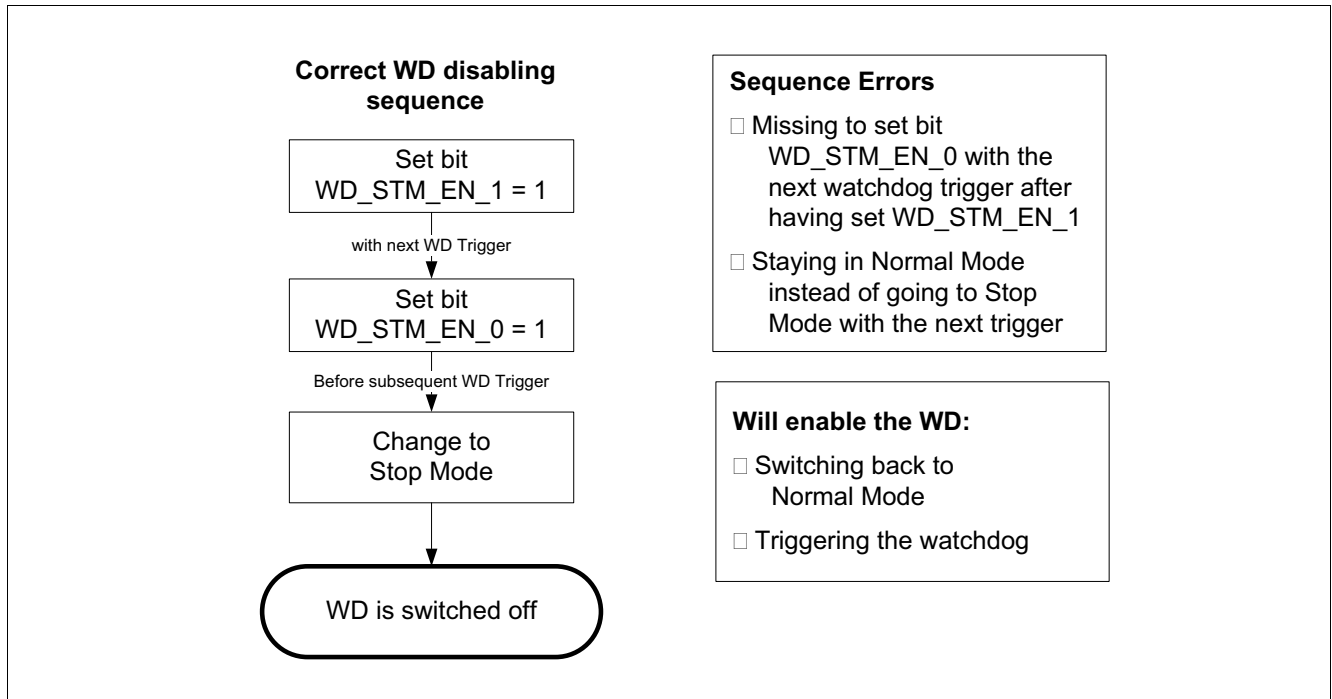

**Figure 49 Watchdog disabling sequence in Stop Mode**

If a sequence error occurs, then the bit **WD\_STM\_EN\_1** will be cleared and the sequence has to be started again.

The watchdog can be enabled by triggering the watchdog in Stop Mode or by switching back to Normal Mode via SPI command. In both cases the watchdog will start with a long open window and the bits **WD\_STM\_EN\_1** and **WD\_STM\_EN\_0** are cleared. After the long open window the watchdog has to be served as configured in the **WD\_CTRL** register.

*Note: The bit **WD\_STM\_EN\_0** will be cleared automatically when the sequence is started and it was 1 before. **WD\_STM\_EN\_0** can also not be set if **WD\_STM\_EN\_1** isn't yet set.*



Supervision Functions

10.3 VSINT Power On Reset

At power up of the device, the Power on Reset is detected when  $VSINT > V_{POR,r}$  and the SPI bit **POR** is set to indicate that all SPI registers are set to POR default settings. VCC1 is starting up and the reset output will be kept low and will only be released once VCC1 has crossed  $V_{RT1,r}$  and after  $t_{RD1}$  has elapsed.

In case  $VSINT < V_{POR,f}$ , an device internal reset will be generated and the device is switched off and will restart in Init Mode at the next VSINT rising. This is shown in **Figure 50**.

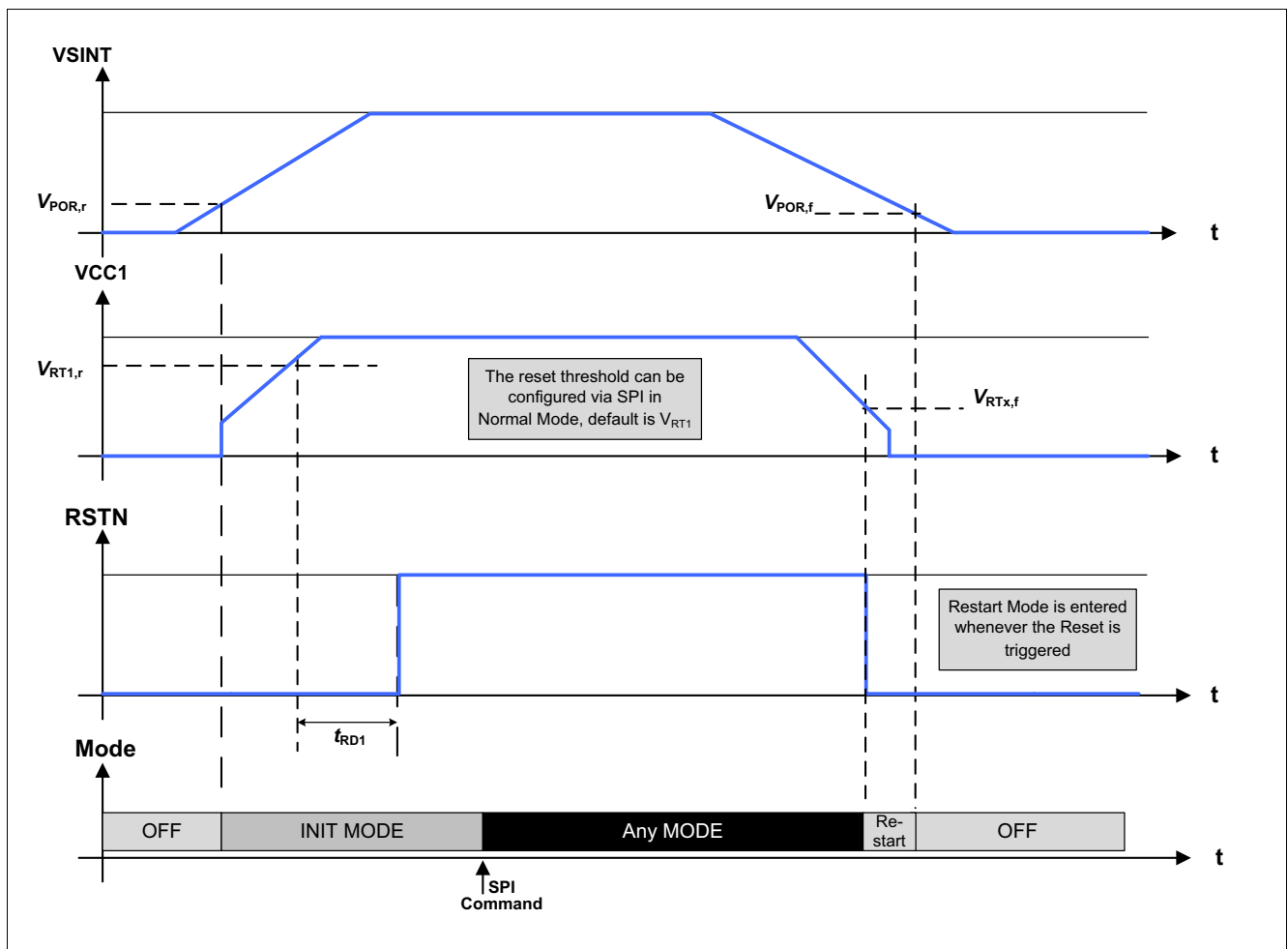

Figure 50 Ramp up / down example of Supply Voltage

## 10.4 VSINT Under- and Overvoltage

### 10.4.1 VSINT Undervoltage

The VSINT under-voltage monitoring is always active in Init Mode, Restart Mode, Normal Mode. If the supply voltage VSINT drops below  $V_{SINT,UV}$  for more than  $t_{VSUV\_FILT}$ , then the device does the following measures:

- The VCC1 short circuit diagnosis becomes inactive (see [Chapter 10.7](#)). However, the thermal protection of the device remains active. If the undervoltage threshold is exceeded (VSINT rising) then the function will be automatically enabled again.
- The status bit **VSINT\_UV** is set and latched until a clear command of **SUP\_STAT** is received.

*Note:* VSINT under-voltage monitoring is not available in Stop Mode due to current consumption saving requirements except if the VCC1 load current is above the active peak threshold ( $I_{PEAK\_TH}$ ) or if VCC1 is below the VCC1 prewarning threshold.

### 10.4.2 VSINT Overvoltage

The VSINT over-voltage monitoring is always active in Init Mode, Restart Mode and Normal Mode. If VSINT rises above  $V_{S,OVD1}$ ,  $V_{S,OVD2}$  for more than  $t_{VSOV\_FILT}$  then the device does the following measures:

1. If HBxMODE = 01b or 10b, then the corresponding MOSFETs are actively turned off with their static discharge current during their respective tHBxCCP Active.
2. Then the charge pump is turned off and the passive discharge is activated.
3. The status bits **VSINT\_OV** is set and latched until a clear command of **SUP\_STAT** is received.

If VS or VSINT fall below  $V_{S,OVD1}$  or  $V_{S,OVD2}$ :

- If **CPEN** = 0 : the charge pumps stays and the bridge driver stay off.
- If **CPEN** = 1 :
  - If **BDOV\_REC** = 0 : Then the charge pump is reactivated but the bridge driver stays off until **VS\_OV** and **VSINT\_OV** are cleared. The current sense amplifier is reactivated (provided that **CSA\_OFF** = 0)
  - If **BDOV\_REC** = 1 : Then the charge pump and the current sense amplifier are reactivated and the bridge driver is enabled if  $V_{CP} > V_{CPUVx}$ , even if **VS\_OV** or **VSINT\_OV** is set. The state of the external MOSFETs is according to the control registers.

## 10.5 VS Under- and Overvoltage

### 10.5.1 VS Undervoltage

The VS under-voltage monitoring is always active in Init-, Restart Mode and Normal Mode. If VS drops below  $V_{S,UV}$  for more than  $t_{VSUV\_FILT}$ , then the device does the following measures:

1. If HBxMODE = 01b or 10b, then the corresponding MOSFETs are actively turned off with their static discharge current during their respective tHBxCCP Active.
2. Then the charge pump is turned off and the passive discharge is activated and the current sense amplifier is turned off.
3. The status bits **VS\_UV** is set and latched until a clear command of **SUP\_STAT** is received.

If VS rises above  $V_{S,UV}$ , then the charge pump is reactivated (provided that **CPEN** is set) and the current sense amplifier is reactivated (provided **CSA\_OFF** = 0) but the bridge driver stays off until **VS\_UV** is cleared. The bridge driver will be reactivated once the VS\_UV bit is cleared.

### 10.5.2 VS Overvoltage

The VS over-voltage monitoring is always active in Init-, Restart Mode and Normal Mode or when the charge pump is enabled. If VS rises above  $V_{S,OVD1}$  or  $V_{S,OVD2}$  for more than  $t_{VS OV\_FILT}$ , then the device does the following measures:

1. If HBxMODE = 01b or 10b, then the corresponding MOSFETs are actively turned off with their static discharge current during their respective tHBxCCP Active.
2. Then the charge pump is turned off and the passive discharge is activated and current sense amplifier is turned off.
3. The status bits **VS\_OV** is set and latched until a clear command of **SUP\_STAT** is received.

If VS and VSINT fall below  $V_{S,OVD1}$  or  $V_{S,OVD2}$ :

- If **CPEN** = 0 : the charge pumps and the bridge driver stay off.
- If **CPEN** = 1 :
  - If **BDOV\_REC** = 0 : Then the charge pump is reactivated (provided that **CPEN** = 1 and **CP\_UV** = 0) but the bridge driver stays off until **VS\_OV** and **VSINT\_OV** are cleared. The current sense amplifier is reactivated provided that **CSA\_OFF** = 0
  - If **BDOV\_REC** = 1 : Then the charge pump and the current sense amplifier are reactivated and the bridge driver is enabled if  $V_{CP} > V_{CPUVX}$ , even if **VS\_OV** or **VSINT\_OV** is set. The state of the external MOSFETs is according to the control registers.

Supervision Functions

## 10.6 VCC1 Over-/ Undervoltage and Undervoltage Prewarning

### 10.6.1 VCC1 Undervoltage and Undervoltage Prewarning

This function is always active when the VCC1 voltage regulator is enabled.

A first-level voltage detection threshold is implemented as a prewarning for the microcontroller. The prewarning event is signaled with the bit **VCC1\_WARN**. No other actions are taken.

As described in [Chapter 10.1](#) and [Figure 51](#), a reset will be triggered (RSTN pulled low) when the  $V_{CC1}$  output voltage falls below the selected undervoltage threshold ( $V_{RTx}$ ). The device will enter Restart Mode and the bit **VCC1\_UV** is set when RSTN is released again.

The hysteresis of the VCC1 undervoltage threshold can be increased by setting the bit **RSTN\_HYS**. In this case always the highest rising threshold ( $V_{RT1,R}$ ) is used for the release of the undervoltage reset. The falling reset threshold remains as configured.

An additional safety mechanism is implemented to avoid repetitive VCC1 undervoltage resets due to high dynamic loads on VCC1:

- A counter is increased for every consecutive VCC1 undervoltage event (regardless on the selected reset threshold).
- The counter is active in Init Mode, Normal Mode and Stop Mode.
- For  $V_S < V_{SINT,UV}$  the counter will be stopped in Normal Mode (i.e. the VS UV comparator is always enabled in Normal Mode).
- A 4th consecutive VCC1 undervoltage event will lead to Fail-Safe Mode entry and to setting the bit **VCC1\_UV\_FS**.
- This counter is cleared:
  - When Fail-Safe Mode is entered.
  - When the bit **VCC1\_UV** is cleared.
  - When a Soft-Reset is triggered.

*Note:* After 4 consecutive **VCC1\_UV** events, the device will enter Fail-Safe Mode and the **VCC1\_UV\_FS** bit is set.

*Note:* The **VCC1\_WARN** or **VCC1\_UV** bits are not set in Sleep Mode as  $V_{CC1} = 0\text{ V}$  in this case.

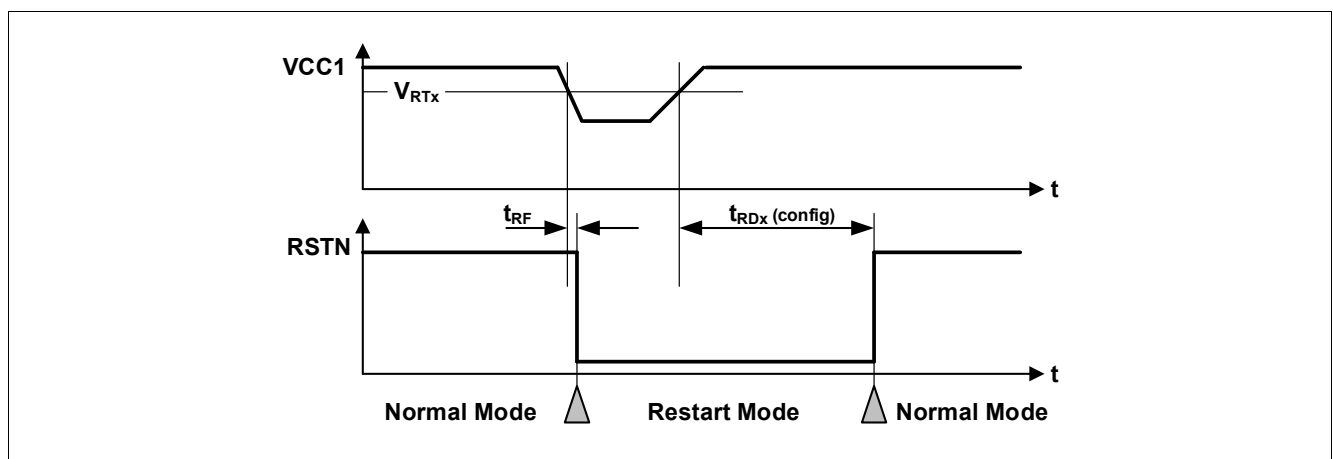

**Figure 51 VCC1 Undervoltage Timing Diagram**

## Supervision Functions

Note: It is recommended to clear the **VCC1\_WARN** and **VCC1\_UV** bit once it is detected by the microcontroller software to verify if the undervoltage still exists or not.

### 10.6.2 VCC1 Overvoltage

For fail-safe reasons a configurable VCC1 over voltage detection feature is implemented. It is active when the VCC1 voltage regulator is enabled.

In case the  $V_{CC1,OV,r}$  threshold is crossed, the device triggers following measures depending on the configuration:

- The bit **VCC1\_OV** is always set.
- Based on the configuration of **VCC1\_OV\_MOD**, different kind of event are generated from device.
- If the **VCC1\_OV\_MOD**=11<sub>B</sub>, in case of the device enters in Fail Safe Mode.

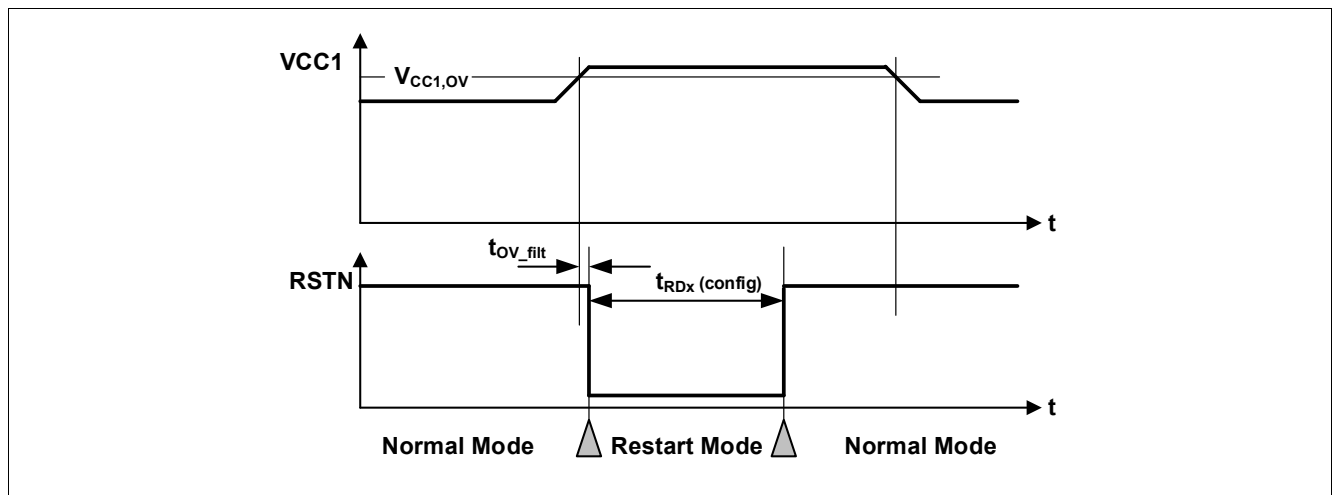

Figure 52 VCC1 Over Voltage Timing Diagram

### 10.7 VCC1 Short Circuit Diagnostics

The short circuit protection feature for  $V_{CC1}$  is implemented as follows:

- The short circuit detection is only enabled if  $V_S > V_{SINT,UV}$ .
- If  $V_{CC1}$  is not above the  $V_{RTX}$  within  $t_{VCC1,SC}$  after device power up or after waking from Sleep Mode or Fail-Safe Mode (i.e. after  $V_{CC1}$  is enabled) then the SPI bit **VCC1\_SC** bit is set,  $V_{CC1}$  is turned off, the FO pin is enabled, **FAILURE** is set and Fail-Safe Mode is entered. The device can be activated again via a wake-up sources.
- The same behavior applies, if  $V_{CC1}$  falls below  $V_{RTX}$  for longer than  $t_{VCC1,SC}$ .

## Supervision Functions

### 10.8 Thermal Protection

Three independent and different thermal protection features are implemented in the device according to the system impact:

- Individual thermal shutdown of specific blocks
- Temperature prewarning of VCC1 voltage regulator
- Device thermal shutdown due to VCC1 overtemperature

#### 10.8.1 Individual Thermal Shutdown

As a first-level protection measure, the charge pump is independently switched off if the respective block reaches the temperature threshold  $T_{jTSD1}$ . Then the **TSD1** bit is set. This bit can only be cleared via SPI once the overtemperature is not present anymore. Independent of the device mode the thermal shutdown protection is only active if the respective block is ON.

The respective modules behave as follows:

- Charge pump: If the charge pump reaches  $T_{jTSD1}$ , then **CP\_OT** is set, **CPEN** is cleared and the activated MOSFETs are actively discharged with their respective static currents during their respective active cross current protection times (tHBxCCP active). When all tHBxCCP active elapsed, then the charge pump and the MOSFETs active discharge are disabled and the current sense amplifier is deactivated. Once the over temperature condition is not present anymore, then **CPEN** has to be configured again by SPI.

*Note: The diagnosis bits are not cleared automatically and have to be cleared via SPI once the overtemperature condition is not present anymore.*

#### 10.8.2 Temperature Prewarning

As a next level of thermal protection a temperature prewarning is implemented if the main supply VCC1 reaches the thermal prewarning temperature threshold  $T_{jPW}$ . Then the status bit **TPW** is set. This bit can only be cleared via SPI once the overtemperature is not present anymore.

#### 10.8.3 Thermal Shutdown

As a highest level of thermal protection a temperature shutdown of the device is implemented if the main supply VCC1 reaches the thermal shutdown temperature threshold  $T_{jTSD2}$ . Once a TSD2 event is detected Fail-Safe Mode is entered. Only when device temperature falls below the TSD2 threshold then the device remains in Fail-Safe Mode for  $t_{TSD2}$  to allow the device to cool down. After this time has expired, the device will automatically change via Restart Mode to Normal Mode (see also [Chapter 5.4.6](#)).

When a TSD2 event is detected, then the status bit **TSD2** is set. This bit can only be cleared via SPI in Normal Mode once the overtemperature is not present anymore.

For increased robustness requirements it is possible to extend the TSD2 waiting time by 64x of  $t_{TSD2}$  after 16 consecutive TSD2 events by setting the SPI bit **TSD2\_DEL**. The counter is incremented with each TSD2 event even if the bit **TSD2** is not cleared. Once the counter has reached the value 16, then the bit **TSD2\_SAFE** is set and the extended TSD2 waiting time is active. The extended waiting time will be kept until **TSD2\_SAFE** is cleared. The TSD counter is cleared when **TSD2** or **TSD2\_DEL** is cleared.

*Note: In case a TSD2 overtemperature occurs while entering Sleep Mode then Fail-Safe Mode is still entered.*

*Note: In case of a TSD2 event, the **FAILURE** bit is set to '1' and the **DEV\_STAT** field is set to '01' inside the **DEV\_STAT** register.*

## Supervision Functions

### 10.9 Bridge driver

This section describes the supervision functions related to the bridge driver.

#### 10.9.1 Bridge driver supervision with activated charge pump

This section describes the supervision functions when the charge pump is activated.

##### 10.9.1.1 Drain-source voltage monitoring

Voltage comparators monitor the activated MOSFETs to protect high-side MOSFETs and low-side MOSFETs against a short circuit respectively to ground and to the battery during ON-state.

A drain-source overvoltage is detected on a low-side MOSFET if the voltage difference between VSHx and SL exceeds the threshold voltage configured by **LS\_VDS** (see [Table 28](#)). Consequently, the corresponding half-bridge is latched off with the static discharge current.

A drain-source overvoltage is detected on a high-side MOSFET if the voltage difference between VS and VSHx exceeds the threshold voltage configured by **HS\_VDS** (see [Table 29](#)). Consequently, the corresponding half-bridge is latched off with the static discharge current.

**Table 28 Low-side drain-source overvoltage threshold**

LSxVDSTH[2:0]	Drain-Source overvoltage threshold for LSx (typical)
000 <sub>B</sub>	160 mV
001 <sub>B</sub>	200 mV (default)
010 <sub>B</sub>	300 mV
011 <sub>B</sub>	400 mV
100 <sub>B</sub>	500 mV
101 <sub>B</sub>	600 mV
110 <sub>B</sub>	800 mV
111 <sub>B</sub>	2 V

**Table 29 High-side drain-source overvoltage threshold**

HSxVDSTH[2:0]	Drain-Source overvoltage threshold for HSx (typical)
000 <sub>B</sub>	160 mV
001 <sub>B</sub>	200 mV (default)
010 <sub>B</sub>	300 mV
011 <sub>B</sub>	400 mV
100 <sub>B</sub>	500 mV
101 <sub>B</sub>	600 mV
110 <sub>B</sub>	800 mV
111 <sub>B</sub>	2 V

**Attention:** 2 V threshold is dedicated for the diagnostic in off-state. It is highly recommended to select another drain-source overvoltage threshold once the routine of the diagnostic in off-state has been performed to avoid additional current consumption from VS and from the charge pump.

The device reports a Drain-Source overvoltage error if both conditions are met:

## Supervision Functions

- After expiration of the blank time .
- If the Drain-Source voltage monitoring exceeds the configured threshold for a duration longer than the configured filter time (refer to [Table 30](#) and [LS\\_VDS](#) TFVDS bits).

**Table 30 Drain-Source overvoltage filter time**

TFVDS[2:0]	Drain-Source overvoltage filter time (typical)
00 <sub>B</sub>	0.5 μs (default)
01 <sub>B</sub>	1 μs
10 <sub>B</sub>	2 μs
11 <sub>B</sub>	6 μs

If a short circuit is detected by the Drain-Source voltage monitoring:

- The impacted half-bridge is latched off with the static discharge current for the configured cross-current protection time.
- The corresponding bit in the status register [DSOV](#) is set.
- The DSOV bit in Global Status Register [GEN\\_STAT](#) is set.

If a Drain-Source overvoltage is detected for one of the MOSFETs, then the status register [DSOV](#) must be cleared in order to re-enable the faulty half-bridge.

### 10.9.1.2 Cross-current protection and drain-source overvoltage blank time

All gate drivers feature a cross-current protection time and a Drain-Source overvoltage blank time.

The cross-current protection avoids the simultaneous activation of the high-side and the low-side MOSFETs of the same half-bridge.

During the blank time, the drain-source overvoltage detection is disabled, to avoid a wrong fault detection during the activation phase of a MOSFET.

*Note: The setting of the cross-current protection and of the blank times may be changed by the microcontroller only if all HBx\_PWM\_EN bits are reset.*

*Note: Changing the Drain-Source overvoltage of a half-bridge x (HBx) in on-state (HBxMODE[1:0]=(0,1) or (1,0)) may result in a wrong VDS overvoltage detection on HBx. Therefore it is highly recommended to change this threshold when HBxMODE[1:0]=(0,0) or (1,1)*

#### 10.9.1.2.1 Cross-current protection

The active and freewheeling cross-current protection times of each half-bridge is configured individually with the control register [CCP\\_BLK](#).

The typical cross-current protection time applied to the freewheeling MOSFET of the half-bridge x is 587 ns + 266 ns x TCCP[3:0]<sub>p</sub>, where TCCP[3:0]<sub>p</sub> is the decimal value of the control bits TCCP.

#### 10.9.1.2.2 Drain-source overvoltage blank time

A configurable blank time for the Drain-Source monitoring is applied at the turn-on of the MOSFETs. During the blank time, a Drain-Source overvoltage error is masked.



## Supervision Functions

For Half-Bridges in PWM mode with  $AFW_x = 1$ :

- the blank time of the PWM MOSFET starts at the expiration of the cross-current protection time of the PWM MOSFET. Refer to [Figure 53](#).
- the blank time of the free-wheeling MOSFET starts after expiration of the cross-current protection time at turn-off of the PWM MOSFET. Refer to [Figure 53](#).

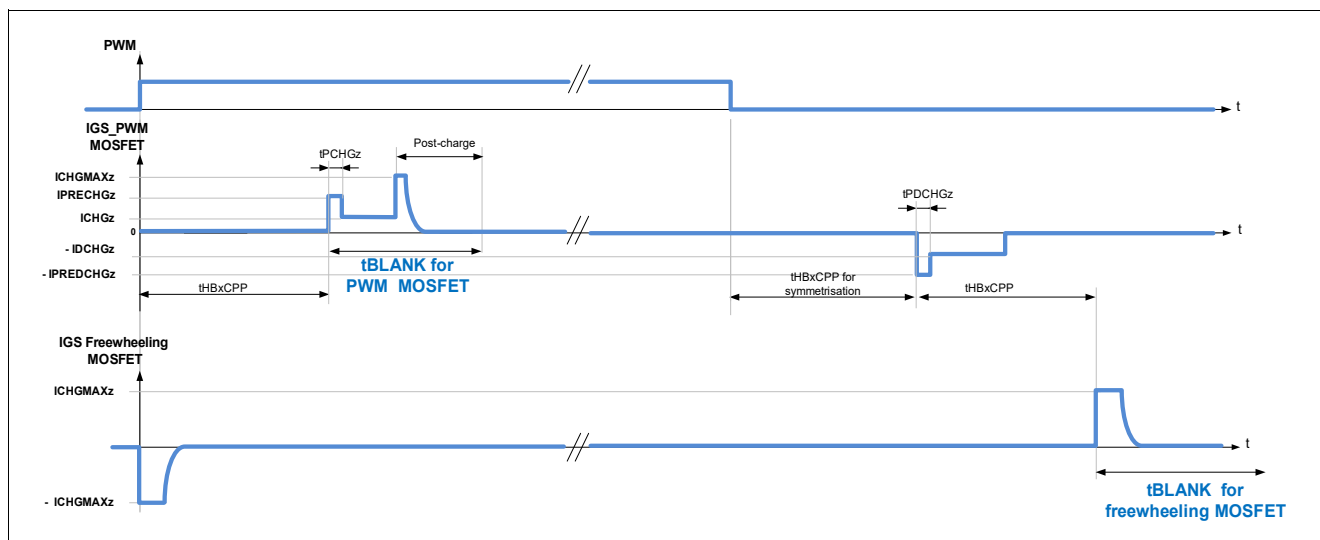

**Figure 53** Blank time for half-bridges in PWM operation with  $AFW = 1$

For statically activated half-bridges, the blank time starts:

- Case 1: at expiration of the cross-current protection ([Figure 23](#)), if the opposite MOSFET was previously activated.
- Case 2: right after the decoding of the SPI command to turn on a MOSFET, if the half-bridge was in high impedance ([Figure 24](#)).

The blank times of the active and FW MOSFETs can be configured with the control register **CCP\_BLK**.

The typical blank is  $587 \text{ ns} + 266 \text{ ns} \times \text{TBLK}[3:0]_D$ .

*Note:* The blank time is implemented at every new activation of a MOSFET, including a recovery from VS undervoltage, VS overvoltage, VSINT overvoltage, CP UV, CP OT.

### 10.9.1.3 OFF-state diagnostic

In order to support the off-state diagnostic ( $HBxMODE = 11$  and  $CPEN = 1$ ), the gate driver of each MOSFET provides pull-up ( $I_{PUDiag}$ ) and a pull-down currents ( $I_{PDDiag}$ ) at the SHx pins. This function requires an activated charge pump.

The pull-up current source of a given half-bridge is on when the half-bridge is active:  $HBxMODE = 01, 10$  or  $11$  and  $CPEN = 1$ .

The pull-down current of each low-side gate driver is activated by the control bits HBx (**HB\_ICHG\_MAX** register).

During the off-state diagnostic routine performed by the microcontroller, the drain-source overvoltage threshold of the relevant half-bridges must be set to 2V nominal. Refer to [Table 28](#). Once the routine is finished, it is highly recommended to decrease the drain-source overvoltage threshold to a lower value, avoiding additional current consumption from the VS input.

## Supervision Functions

The following failures can be detected:

- MOSFET short circuit to GND
- MOSFET short circuit the battery
- Open load (disconnected motor)

The status of the output voltages VOUTx, can be read back with status bit HBxVOUT (register **GEN\_STAT**) when the corresponding half-bridge is in off-state (HBxMODE[1:0] = 11).

*Note:* HBxVOUT = 0 if the half-bridge x is not actively off (HBxMODE[1:0] = (0,0), (0,1) or (1,0) and **CPEN**=1) or when the charge pump is deactivated (**CPEN**=0).

### 10.9.1.4 Charge pump undervoltage

The voltage of the charge pump output (VCP) is monitored in order to ensure a correct control of the external MOSFETs.

The charge pump undervoltage threshold is configurable by the control bits **FET\_LVL** and **CPUVTH**.

**Table 31 Charge pump undervoltage thresholds**

	<b>FET_LVL = 0</b>	<b>FET_LVL = 1</b>
CPUVTH = 0	<b>V<sub>CPUV1</sub></b> (6 V typ. referred to VS)	<b>V<sub>CPUV3</sub></b> (7.5 V typ. referred to VS)
CPUVTH = 1	<b>V<sub>CPUV2</sub></b> (6.5 V typ. referred to VS)	<b>V<sub>CPUV4</sub></b> (8 V typ. referred to VS)

If VCP falls below the configured charge pump undervoltage threshold while **CPEN** = 1:

- If one of the MOSFET is on, then all MOSFETs are actively turned off with their configured static discharge current during their respective tHBxCCP active.
- Then the gate drivers are turned off and CSA is turned off.
- **CP\_UV** is set and latched.

The **CP\_UV** is reset and the normal operation is resumed once **SUP\_STAT** is cleared and VCP > VCPUV.

The charge pump undervoltage detection is blanked (**t<sub>CPUVBLANK</sub>**) during each new activation of the charge pump<sup>1)</sup>.

### 10.9.1.5 Switching parameters of MOSFETs in PWM mode

The effective switching parameters of the active MOSFETs (**EN\_GEN\_CHECK**=1), respectively PWM MOSFET (**EN\_GEN\_CHECK**=0) can be read out with dedicated status registers:

- The turn-on and turn off delays, noted tDON and tDOFF are reported by the status register **EFF\_TDON\_OFF1**, **EFF\_TDON\_OFF2**, **EFF\_TDON\_OFF3**.
- The rise and fall times, noted tRISE and tFALL, are reported by the status register **TRISE\_FALL1**, **TRISE\_FALL2**, **TRISE\_FALL3**.

### 10.9.2 Low-side drain-source voltage monitoring during braking

The low-side MOSFETs are turned-on while the charge pump is deactivated in the following conditions:

- The slam mode is activated and PWM1/CRC is High.

1) Including **CPEN** set to 1, recovery from VS under/overvoltage, VSINT overvoltage and CP\_OT

## Supervision Functions

- The parking braking mode is activated and the device is in Sleep Mode or Stop Mode.
- VS overvoltage brake is activated and ( $VS > VS$  Overvoltage braking or  $VSINT > VSINT$  Overvoltage braking) in all device modes if **OV\_BRK\_EN** is set.

Under these conditions, the drain-source voltage of the low-sides are monitored and the applied drain-source overvoltage thresholds are according to **VDSTH\_BRK**.

The applied blank time, which starts at the beginning of the brake activation, is:

- $t_{BLK\_BRAKE1}$  if **TBLK\_BRK** = 0
- $t_{BLK\_BRAKE2}$  if **TBLK\_BRK** = 1

During the blank time, a drain-source overvoltage of the low-sides is masked.

The applied filter time is  $t_{FVDS\_BRAKE}$ .

If a drain-source overvoltage is detected during braking, then all low-side MOSFETs are turned off (latched) within  $t_{OFF\_BRAKE}$ . **SLAM\_LSx\_DIS** (**BRAKE**, **SLAM**, **PARK\_BRK\_EN**, **OV\_BRK\_EN** are unchanged. The corresponding status bit LSxDISOV\_BRK is set in **DSOV**.

The low-sides can be reactivated only if all LSxDISOV\_BRK bits (**DSOV**) are cleared (even in slam mode with the respective LSx disabled by the **SLAM\_LSx\_DIS** bit).

If any of the status bits LSxDISOV\_BRK is set, then the charge pump stays off (**CPEN**=1 command is accepted but the charge pump stays disabled until all LSxDISOV\_BRK are cleared).

### 10.9.3 VS or VSINT Overvoltage braking

The VS and VSINT overvoltage braking is activated if the **OV\_BRK\_EN** bit in **BRAKE** register is set regardless of the device mode.

If VS, respectively VSINT, exceeds  $V_{OVBR,cfgr}$  ( $x = 0$  to 7), then all low-sides MOSFETs are turned-on within  $t_{ON\_BRAKE}$ . The status bits **VS\_OVBRAKE\_ST**, respectively **VSINT\_OVBRAKE\_ST**, is set and latched (see **DSOV** register).

If VS and VSINT decrease below  $V_{OVBR,cfgr} - V_{HYS,cfgr}$  ( $x = 0$  to 7), then all low-sides MOSFETs are turned-off within  $t_{OFF\_BRAKE}$  after the filter time  $t_{OV\_BR\_FLT}$ .

If ( $VSHx - VSL$ ) exceeds the configured threshold, then all low-sides MOSFETs are turned-off within  $t_{OFF\_BRAKE}$  after the filter time  $t_{FVDS\_BRAKE}$ . The threshold is:

- $V_{VDSMONTH0\_BRAKE}$  if **VDSTH\_BRK** = 0
- $V_{VDSMONTH1\_BRAKE}$  if **VDSTH\_BRK** = 1

## 10.10 Current sense amplifier

The current sense amplifier (CSA) allows current measurements with external shunt resistor in low-side configuration. The CSA is supplied by the charge pump (CP). Therefore, if the CP is off, then the CSA is deactivated.

### 10.10.1 Unidirectional and bidirectional operation

The current sense amplifier (CSA) can work either as unidirectional or bi-directional operation. Refer to CSA register.

**Unidirectional operation** **CSD** = 0

## Supervision Functions

In unidirectional operation, the CSA is optimized to measure the current flowing through the external shunt resistor when  $V_{CSAP} \geq V_{CSAN}$ .

$$V_{CSO} = V_{REF\ Unidir} + (V_{CSAP} - V_{CSAN} + V_{OS}) \times G_{DIFF} \text{ provided that } V_{CSO} \text{ is in the linear range}^{1) 2)}$$

### Bidirectional operation **CSD = 1**

In bidirectional operation, the CSA measures the current flowing through the external shunt resistor in both directions:  $V_{CSAP} \geq V_{CSAN}$  or  $V_{CSAP} \leq V_{CSAN}$ .

The output CSO works at half-scale range:  $V_{CSO} = V_{REF\ Bidir} + (V_{CSAP} - V_{CSAN} + V_{OS}) \times G_{DIFF}$ , provided that VCSO is in the linear range<sup>2)</sup>.

### 10.10.2 Gain configuration

The gain of the current sense amplifier is configurable by the configuration bits CSAG bits. Refer to [Table 32](#).

**Table 32 Configuration of the current sense amplifier gain**

CSAG[1:0]	Current sense amplifier gain $G_{DIFF}$
00 <sub>B</sub>	$G_{DIFF10}$
01 <sub>B</sub>	$G_{DIFF20}$
10 <sub>B</sub>	$G_{DIFF40}$
11 <sub>B</sub>	$G_{DIFF60}$

### 10.10.3 Overcurrent Detection

A comparator at CSO detects overcurrent conditions. The overcurrent threshold is configurable with the OCTH bits. Refer to [Table 33](#) for unidirectional operation and [Table 34](#) for bidirectional operation.

**Table 33 Overcurrent detection thresholds in unidirectional operation (CSD = 0)**

OCTH[1:0]	Typical Overcurrent Detection Threshold
00 <sub>B</sub>	$V_{CSO} > V_{CC1}/2$
01 <sub>B</sub>	$V_{CSO} > V_{CC1}/2 + V_{CC1}/10$
10 <sub>B</sub>	$V_{CSO} > V_{CC1}/2 + 2 \times V_{CC1}/10$
11 <sub>B</sub>	$V_{CSO} > V_{CC1}/2 + 3 \times V_{CC1}/10$

1) Valid if  $0.5\text{ V} \leq V_{CSO} \leq V_{CC1} - 0.5\text{ V}$ .

2) VCSO is clamped between VCC1 and GND.

Supervision Functions

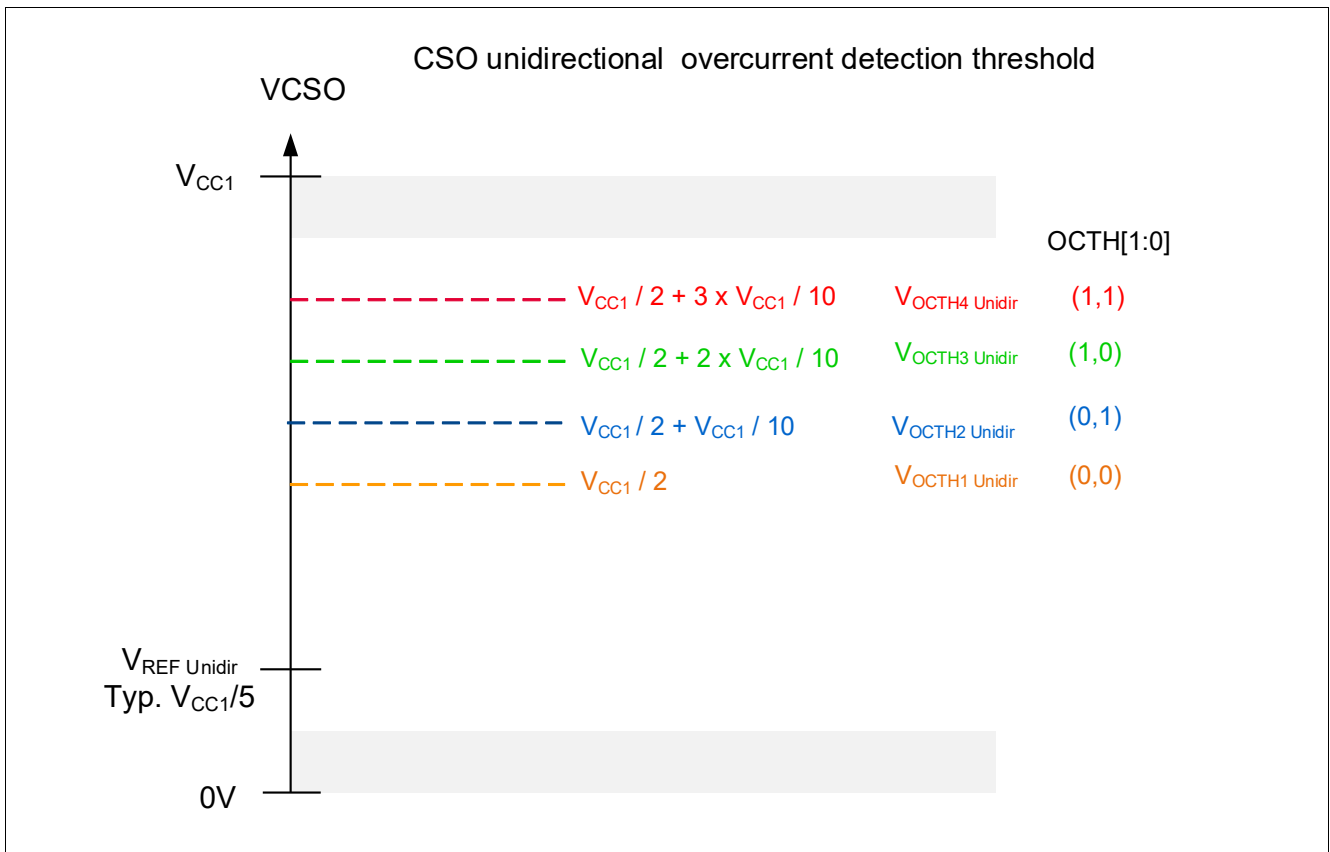
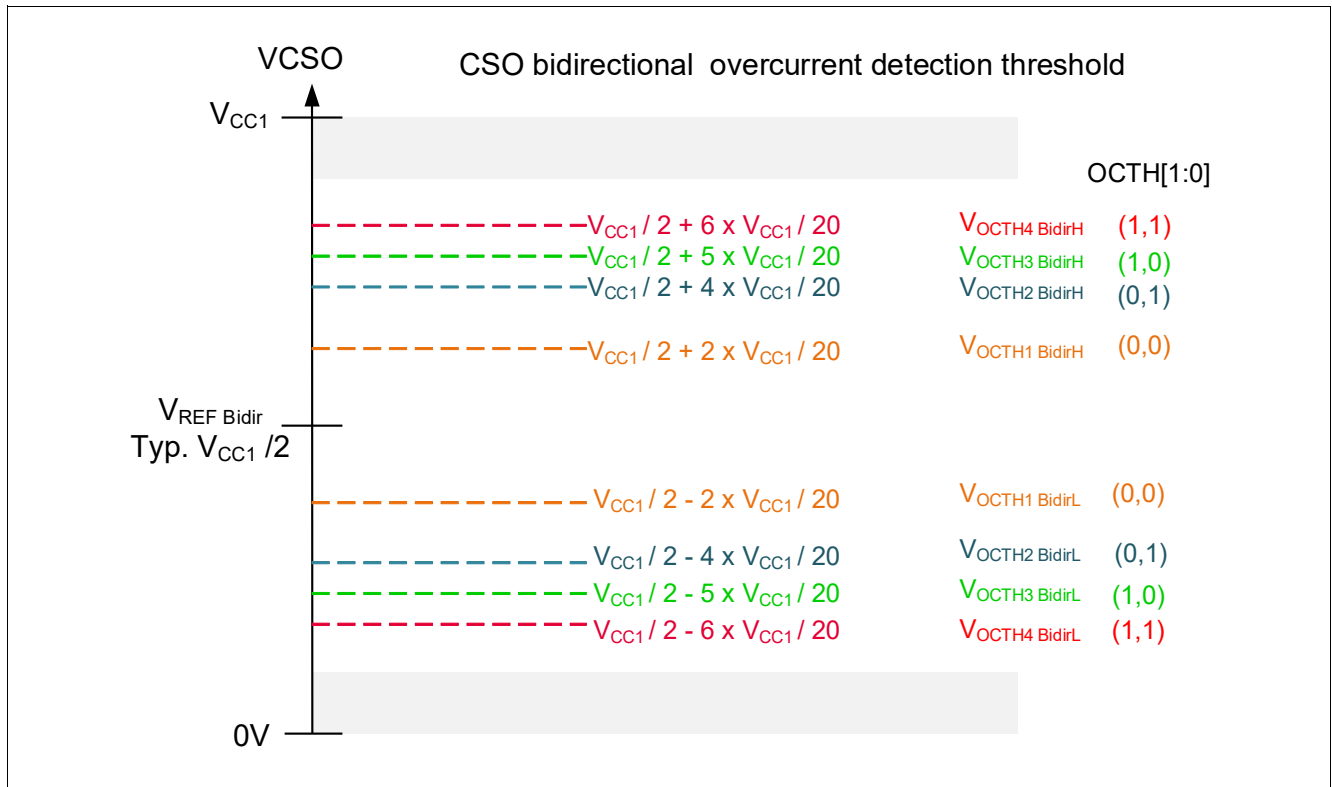

Figure 54 Overcurrent detection thresholds in unidirectional operation (CSD = 0)

Supervision Functions

**Table 34 Overcurrent detection thresholds in bidirectional operation (CSD = 1)**

OCTHx[1:0]	Typical Overcurrent Detection Threshold
00 <sub>B</sub>	$V_{CSO} > V_{CC1}/2 + 2 \times V_{CC1}/20$ or $V_{CSO} < V_{CC1}/2 - 2 \times V_{CC1}/20$
01 <sub>B</sub>	$V_{CSO} > V_{CC1}/2 + 4 \times V_{CC1}/20$ or $V_{CSO} < V_{CC1}/2 - 4 \times V_{CC1}/20$
10 <sub>B</sub>	$V_{CSO} > V_{CC1}/2 + 5 \times V_{CC1}/20$ or $V_{CSO} < V_{CC1}/2 - 5 \times V_{CC1}/20$
11 <sub>B</sub>	$V_{CSO} > V_{CC1}/2 + 6 \times V_{CC1}/20$ or $V_{CSO} < V_{CC1}/2 - 6 \times V_{CC1}/20$



**Figure 55 Overcurrent detection thresholds in bidirectional operation (CSD = 1)**

It is possible to program the device behavior when an overcurrent condition is detected:

- OCEN bit = 0 (see CSA): the device only reports the overcurrent event ( bit is set), without any change of the gate driver states.
- OCEN bit = 1 (see CSA): the device reports the overcurrent event ( bit is set) and actively turns off all MOSFETs with static discharge current:
  - The MOSFETs can be reactivated by clearing **OC\_CSA** or by resetting the **OCEN** bit.

The overcurrent filter time is configurable (refer to  $t_{FOC}$ ) by the OCFILT control bits.

$t_{FOC}$  refers to the output of the current sense amplifier. The CSO settling time (2  $\mu$ s max,  $t_{SET}$ ) and the analog propagation delay (< 1  $\mu$ s) are not taken into account by the overcurrent filter time.

### 10.10.4 CSO output capacitor

The capacitor connected to CSO (CCSO) must be between 10 pF and 2.2 nF. The control bit **CSO\_CAP** optimizes the current consumption for  $CCSO < 400$  pF or  $400$  pF <  $CCSO < 2.2$  nF<sup>1)</sup>.

**Supervision Functions**

**10.11 Electrical Characteristics**

**Table 35 Electrical Characteristics**

$V_{SINT} = 5.5 \text{ V to } 28 \text{ V}$ ;  $T_j = -40^\circ\text{C to } +175^\circ\text{C}$ ; Normal Mode; all voltages with respect to ground; positive current defined flowing into pin; unless otherwise specified.

Parameter	Symbol	Values			Unit	Note or Test Condition	Number
		Min.	Typ.	Max.			
<b>VCC1 Monitoring; VCC1 = 5.0V Version</b>							
Undervoltage Prewarning Threshold Voltage PW,f	$V_{PW,f}$	4.53	4.70	4.84	V	VCC1 falling, SPI bit is set	P_13.12.1
Undervoltage Prewarning Threshold Voltage PW,r	$V_{PW,r}$	4.60	4.75	4.90	V	VCC1 rising	P_13.12.2
Undervoltage Prewarning Threshold Voltage hysteresis	$V_{PW,hys}$	30	50	90	mV	<sup>6)</sup>	P_13.12.3
VCC1 UV Prewarning Detection Filter Time	$t_{VCC1,PW\_F}$	5	10	14	us	<sup>2)</sup> rising and falling	P_13.12.4
Reset Threshold Voltage RT1,f	$V_{RT1,f}$	4.45	4.6	4.75	V	default setting; VCC1 falling	P_13.12.5
Reset Threshold Voltage RT1,r	$V_{RT1,r}$	4.58	4.74	4.90	V	default setting; VCC1 rising	P_13.12.6
Reset Threshold Voltage RT2,f	$V_{RT2,f}$	3.70	3.85	4.00	V	VCC1 falling	P_13.12.7
Reset Threshold Voltage RT2,r	$V_{RT2,r}$	3.85	4.0	4.15	V	VCC1 rising	P_13.12.8
Reset Threshold Voltage RT3,f	$V_{RT3,f}$	3.24	3.40	3.55	V	$V_{SINT} \geq 4 \text{ V}$ ; VCC1 falling	P_13.12.9
Reset Threshold Voltage RT3,r	$V_{RT3,r}$	3.39	3.54	3.70	V	$V_{SINT} \geq 4 \text{ V}$ ; VCC1 rising	P_13.12.10
Reset Threshold Voltage RT4,f	$V_{RT4,f}$	2.49	2.65	2.8	V	$V_{SINT} \geq 4 \text{ V}$ ; VCC1 falling	P_13.12.11
Reset Threshold Voltage RT4,r	$V_{RT4,r}$	2.65	2.76	2.95	V	$V_{SINT} \geq 4 \text{ V}$ ; VCC1 rising	P_13.12.12
Reset Threshold Hysteresis	$V_{RT,hys}$	70	140	220	mV	<sup>6)</sup>	P_13.12.13
VCC1 Over Voltage Detection Threshold Voltage	$V_{CC1,OV,r}$	5.5	5.65	5.8	V	<sup>1)6)</sup> rising VCC1	P_13.12.26
VCC1 Over Voltage Detection Threshold Voltage	$V_{CC1,OV,f}$	5.4	5.55	5.7	V	<sup>6)</sup> falling VCC1	P_13.12.27
VCC1 OV Detection Filter Time	$t_{VCC1,OV\_F}$	51	64	80	us	<sup>2)</sup>	P_13.12.31

1) for  $400 \text{ pF} < \text{CCSO} < 2.2 \text{ nF}$ , a seial resistor of min. 45 Ohm between the CSO pin and the CCSO capacitor is required,

## Supervision Functions

**Table 35 Electrical Characteristics** (cont'd)

$V_{SINT} = 5.5 \text{ V to } 28 \text{ V}$ ;  $T_j = -40^\circ\text{C to } +175^\circ\text{C}$ ; Normal Mode; all voltages with respect to ground; positive current defined flowing into pin; unless otherwise specified.

Parameter	Symbol	Values			Unit	Note or Test Condition	Number
		Min.	Typ.	Max.			
VCC1 Short to GND Filter Time	$t_{VCC1,SC}$	3.2	4	4.8	ms	<sup>2)</sup> blanking time during power-up, short circuit detection for $V_S \geq V_{S,UV}$	P_13.12.32

### Reset Generator; Pin RSTN

Reset Low Output Voltage	$V_{RSTN,L}$	–	0.2	0.4	V	$I_{RSTN} = 1 \text{ mA}$ for $V_{CC1} \geq 1 \text{ V}$ & $V_S \geq V_{POR,f}$	P_13.12.33
Reset High Output Voltage	$V_{RSTN,H}$	$0.8 \times V_{CC1}$	–	$V_{CC1} + 0.3 \text{ V}$	V	$I_{RSTN} = -20 \mu\text{A}$	P_13.12.34
Reset Pull-up Resistor	$R_{RSTN}$	10	20	40	k $\Omega$	$V_{RSTN} = 0 \text{ V}$	P_13.12.35
Reset Filter Time	$t_{RF}$	4	10	26	$\mu\text{s}$	<sup>2)</sup> $V_{CC1} < V_{RT1x}$ to RSTN = L see also <b>Chapter 10.3</b>	P_13.12.36
Reset Delay Time 1	$t_{RD1}$	8	10	12	ms	<sup>2)</sup> <b>RSTN_DEL</b> = 0	P_13.12.37
Reset Delay Time 2	$t_{RD2}$	1.6	2	2.4	ms	<sup>2)</sup> <b>RSTN_DEL</b> = 1	P_13.12.64

### Watchdog Generator / Internal Oscillator

Long Open Window	$t_{LW}$	160	200	240	ms	<sup>2)</sup>	P_13.12.42
Internal Clock Generator Frequency	$f_{CLKSBC,1}$	0.8	1.0	1.2	MHz	–	P_13.12.43

### Minimum Waiting time during Fail-Safe Mode

Min. waiting time Fail-Safe	$t_{FS,min}$	80	100	120	ms	<sup>2)3)</sup>	P_13.12.45
-----------------------------	--------------	----	-----	-----	----	-----------------	------------

### Power-on Reset, Over / Undervoltage Protection

VSINT Power on reset rising	$V_{POR,r}$	–	–	4.5	V	VSINT increasing	P_13.12.46
VSINT Power on reset falling	$V_{POR,f}$	–	–	3	V	VSINT decreasing	P_13.12.47
VSINT Undervoltage Detection Threshold	$V_{SINT,UV}$	5.3	–	6.0	V	Supply UV threshold for VCC1 SC detection; hysteresis included; includes rising and falling threshold	P_13.12.48



**Supervision Functions**

**Table 35 Electrical Characteristics (cont'd)**

$V_{SINT} = 5.5 \text{ V to } 28 \text{ V}$ ;  $T_j = -40^\circ\text{C to } +175^\circ\text{C}$ ; Normal Mode; all voltages with respect to ground; positive current defined flowing into pin; unless otherwise specified.

Parameter	Symbol	Values			Unit	Note or Test Condition	Number
		Min.	Typ.	Max.			
<b>Charge Pump Undervoltage</b>							
Charge Pump Undervoltage Referred to VS	$V_{CPUV1}$	5.4	5.9	6.4	V	<b>FET_LVL</b> = 0 <b>CPUVTH</b> = 0 falling threshold, $VS \geq 6 \text{ V}$	P_13.12.59
Charge Pump Undervoltage Referred to VS	$V_{CPUV2}$	5.85	6.35	6.85	V	<b>FET_LVL</b> = 0 <b>CPUVTH</b> = 1 falling threshold, $VS \geq 6 \text{ V}$	P_13.12.60
Charge Pump Undervoltage Referred to VS	$V_{CPUV3}$	6.85	7.35	7.85	V	<b>FET_LVL</b> = 1 <b>CPUVTH</b> = 0 falling threshold, $VS \geq 6 \text{ V}$	P_13.12.61
Charge Pump Undervoltage Referred to VS	$V_{CPUV4}$	7.5	8	8.5	V	<b>FET_LVL</b> = 1 <b>CPUVTH</b> = 1 falling threshold, $VS \geq 6 \text{ V}$	P_13.12.62
Charge Pump Undervoltage Filter Time	$t_{CPUV}$	51	64	80	$\mu\text{s}$	<sup>6)</sup> $VS \geq 6 \text{ V}$	P_13.12.63
Charge Pump Undervoltage Blank Time	$t_{CPUVBLANK}$	400	500	600	$\mu\text{s}$	<sup>6)</sup> $VS \geq 6 \text{ V}$	P_13.12.175
<b>VS monitoring</b>							
VS undervoltage threshold	$V_{S,UV}$	4.7	-	5.4	V	hysteresis included	P_13.12.66
VS overvoltage threshold detection 1	$V_{S,OVD1}$	19	-	22.5	V	hysteresis included, <b>VS_OV_SEL</b> = 0	P_13.12.68
VS overvoltage threshold detection 2	$V_{S,OVD2}$	27.75	-	31.25	V	hysteresis included, <b>VS_OV_SEL</b> = 1	P_13.12.65
VS undervoltage filter time	$t_{VSUV\_FILT}$	5	10	14	$\mu\text{s}$	<sup>2)</sup> rising and falling	P_13.12.71
VS overvoltage filter time	$t_{VSOV\_FILT}$	5	10	14	$\mu\text{s}$	<sup>2)</sup> rising and falling	P_13.12.72
<b>Off-state open load diagnosis</b>							
Pull-up diagnosis current	$I_{PUDiag}$	-600	-400	-270	$\mu\text{A}$	$VS \geq 6 \text{ V}$	P_13.12.73
Pull-down diagnosis current	$I_{PDDiag}$	1600	2200	2800	$\mu\text{A}$	$VS \geq 6 \text{ V}$	P_13.12.74
Diagnosis current ratio	$I_{Diag\_ratio}$	4.25	5.25	6.25		Ratio $I_{PDDiag} / I_{PUDiag}$	P_13.12.302

**Supervision Functions**

**Table 35 Electrical Characteristics (cont'd)**

$V_{SINT} = 5.5 \text{ V to } 28 \text{ V}$ ;  $T_j = -40^\circ\text{C to } +175^\circ\text{C}$ ; Normal Mode; all voltages with respect to ground; positive current defined flowing into pin; unless otherwise specified.

Parameter	Symbol	Values			Unit	Note or Test Condition	Number
		Min.	Typ.	Max.			
<b>Drain-source monitoring CP activated</b>							
Blank time	$t_{BLANK}$	typ-20%	587 +266 xTBLK	typ+20%	ns	<sup>6)</sup> TBLK: decimal value of TBLK[3:0], $VS \geq 6 \text{ V}$	P_13.12.75
Cross-current protection time	$t_{CCP}$	typ-20%	587 +266 xTCCP	typ+20%	ns	<sup>6)</sup> TCCP: decimal value of TCCPx[3:0], $VS \geq 6 \text{ V}$	P_13.12.76
HS/LS Drain-source overvoltage 0	$V_{VDSMONTH0\_CPON}$	0.115	0.16	0.195	V	$VDSTH[2:0] = 000_B$ , $VS \geq 6 \text{ V}$ , $TFVDS = 00_B$	P_13.12.77
HS/LS Drain-source overvoltage 1	$V_{VDSMONTH1\_CPON}$	0.16	0.2	0.25	V	$VDSTH[2:0] = 001_B$ , $VS \geq 6 \text{ V}$ , $TFVDS = 00_B$	P_13.12.78
HS/LS Drain-source overvoltage 2	$V_{VDSMONTH2\_CPON}$	0.24	0.3	0.36	V	$VDSTH[2:0] = 010_B$ , $VS \geq 6 \text{ V}$ , $TFVDS = 00_B$	P_13.12.79
HS/LS Drain-source overvoltage 3	$V_{VDSMONTH3\_CPON}$	0.32	0.4	0.48	V	$VDSTH[2:0] = 011_B$ , $VS \geq 6 \text{ V}$ , $TFVDS = 00_B$	P_13.12.80
HS/LS Drain-source overvoltage 4	$V_{VDSMONTH4\_CPON}$	0.4	0.5	0.6	V	$VDSTH[2:0] = 100_B$ , $VS \geq 6 \text{ V}$ , $TFVDS = 00_B$	P_13.12.81
HS/LS Drain-source overvoltage 5	$V_{VDSMONTH5\_CPON}$	0.48	0.6	0.72	V	$VDSTH[2:0] = 101_B$ , $VS \geq 6 \text{ V}$ , $TFVDS = 00_B$	P_13.12.82
HS/LS Drain-source overvoltage 6	$V_{VDSMONTH6\_CPON}$	0.64	0.8	0.96	V	$VDSTH[2:0] = 110_B$ , $VS \geq 6 \text{ V}$ , $TFVDS = 00_B$	P_13.12.83
HS/LS Drain-source overvoltage 7	$V_{VDSMONTH7\_CPON}$	1.75	2.0	2.25	V	$VDSTH[2:0] = 111_B$ , $VS \geq 6 \text{ V}$ , $TFVDS = 00_B$	P_13.12.84
<b>Drain-Source monitoring - Slam mode, parking braking and VS overvoltage braking, VS or VSINT <math>\geq 8 \text{ V}</math></b>							
Blank time	$t_{BLK\_BRAKE1}$	4.5	7	9.5	$\mu\text{s}$	<b>TBLK_BRK</b> = 0, $VS$ or $VSINT \geq 8 \text{ V}$	P_13.12.85
Blank time	$t_{BLK\_BRAKE2}$	9	11	13	$\mu\text{s}$	<b>TBLK_BRK</b> = 1, $VS$ or $VSINT \geq 8 \text{ V}$	P_13.12.86
VDS Filter time	$t_{FVDS\_BRAKE}$	0.5	1	2.5	$\mu\text{s}$	$VS$ or $VSINT \geq 8 \text{ V}$	P_13.12.87
LS Drain-source monitoring thresholds	$V_{VDSMONTH0\_BRAKE}$	0.56	0.8	1.05	V	$VS$ or $VSINT \geq 8 \text{ V}$ <b>VDSTH_BRK</b> = 0	P_13.12.89
LS Drain-source monitoring thresholds	$V_{VDSMONTH1\_BRAKE}$	0.15	0.22	0.29	V	$VS$ or $VSINT \geq 8 \text{ V}$ <b>VDSTH_BRK</b> = 1	P_13.12.90
<b>VS Overvoltage Braking Mode</b>							
VS Overvoltage braking config 0 rising	$V_{OVBR, cfg0, r}$	25.65	27	28.35	V	<b>OV_BRK_TH</b> =000 <sub>B</sub>	P_13.12.97
VS Overvoltage braking config 1 rising	$V_{OVBR, cfg1, r}$	26.60	28	29.40	V	<b>OV_BRK_TH</b> =001 <sub>B</sub>	P_13.12.98

**Supervision Functions**

**Table 35 Electrical Characteristics (cont'd)**

$V_{SINT} = 5.5 \text{ V to } 28 \text{ V}$ ;  $T_j = -40^\circ\text{C to } +175^\circ\text{C}$ ; Normal Mode; all voltages with respect to ground; positive current defined flowing into pin; unless otherwise specified.

Parameter	Symbol	Values			Unit	Note or Test Condition	Number
		Min.	Typ.	Max.			
VS Overvoltage braking config 2 rising	$V_{OVBR, cfg2, r}$	27.55	29	30.45	V	<b>OV_BRK_TH=010<sub>B</sub></b>	P_13.12.99
VS Overvoltage braking config 3 rising	$V_{OVBR, cfg3, r}$	28.50	30	31.50	V	<b>OV_BRK_TH=011<sub>B</sub></b>	P_13.12.100
VS Overvoltage braking config 4 rising	$V_{OVBR, cfg4, r}$	29.45	31	32.55	V	<b>OV_BRK_TH=100<sub>B</sub></b>	P_13.12.101
VS Overvoltage braking config 5 rising	$V_{OVBR, cfg5, r}$	30.40	32	33.60	V	<b>OV_BRK_TH=101<sub>B</sub></b>	P_13.12.102
VS Overvoltage braking config 6 rising	$V_{OVBR, cfg6, r}$	31.35	33	34.65	V	<b>OV_BRK_TH=110<sub>B</sub></b>	P_13.12.103
VS Overvoltage braking config 7 rising	$V_{OVBR, cfg7, r}$	32.30	34	35.70	V	<b>OV_BRK_TH=111<sub>B</sub></b>	P_13.12.104
VS Overvoltage braking config 0	$V_{HYS, cfg0}$	0.64	0.75	0.85	V	<b>OV_BRK_TH=000<sub>B</sub></b>	P_13.12.105
VS Overvoltage braking config 1	$V_{HYS, cfg1}$	0.74	0.82	0.9	V	<b>OV_BRK_TH=001<sub>B</sub></b>	P_13.12.109
VS Overvoltage braking config 2	$V_{HYS, cfg2}$	0.80	0.89	0.98	V	<b>OV_BRK_TH=010<sub>B</sub></b>	P_13.12.113
VS Overvoltage braking config 3	$V_{HYS, cfg3}$	0.85	0.95	1.05	V	<b>OV_BRK_TH=011<sub>B</sub></b>	P_13.12.117
VS Overvoltage braking config 4	$V_{HYS, cfg4}$	0.93	1.03	1.13	V	<b>OV_BRK_TH=100<sub>B</sub></b>	P_13.12.121
VS Overvoltage braking config 5	$V_{HYS, cfg5}$	0.97	1.08	1.19	V	<b>OV_BRK_TH=101<sub>B</sub></b>	P_13.12.125
VS Overvoltage braking config 6	$V_{HYS, cfg6}$	1.03	1.15	1.27	V	<b>OV_BRK_TH=110<sub>B</sub></b>	P_13.12.129
VS Overvoltage braking config 7	$V_{HYS, cfg7}$	1.1	1.23	1.36	V	<b>OV_BRK_TH=111<sub>B</sub></b>	P_13.12.133
VS and VSINT overvoltage braking filter time	$t_{OV\_BR\_FLT}$	10	15	20	$\mu\text{s}$	<sup>6)</sup>	P_13.12.200

**Current sense amplifier<sup>4)</sup>**

Operating common mode input voltage range referred to GND (CSAP - GND) or (CSAN- GND)	$V_{CM}$	-2.0	-	2.0	V		P_13.12.138
---	----------	------	---	-----	---	--	-------------

**Supervision Functions**

**Table 35 Electrical Characteristics (cont'd)**

$V_{SINT} = 5.5 \text{ V to } 28 \text{ V}$ ;  $T_j = -40^\circ\text{C to } +175^\circ\text{C}$ ; Normal Mode; all voltages with respect to ground; positive current defined flowing into pin; unless otherwise specified.

Parameter	Symbol	Values			Unit	Note or Test Condition	Number
		Min.	Typ.	Max.			
Common Mode Rejection Ratio	CMRR	63 69 75 77	- - - -	- - - -	dB	<sup>6)</sup> CSAG = (0,0) CSAG = (0,1) CSAG = (1,0) CSAG = (1,1) DC to 50 kHz $V_{CM} = -2 \dots 2 \text{ V}$ $V_{CSAP} = V_{CSAN}$	P_13.12.139
Settling time to 98%	$t_{SET}$	-	1500	2000	ns	<sup>6)</sup>	P_13.12.140
Settling time to 98% after gain change	$t_{SET\_GAIN}$	-	-	5000	ns	<sup>6)</sup> After gain change from CSN rising edge	P_13.12.141
Input Offset voltage	$V_{OS}$	-1	0	1	mV		P_13.12.142
Current Sense Amplifier DC Gain (uncalibrated)	$G_{DIFF10}$	9.91	10.04	10.17	V/V	CSAG = (0,0)	P_13.12.143
Current Sense Amplifier DC Gain (uncalibrated)	$G_{DIFF20}$	19.79	20.05	20.31	V/V	CSAG = (0,1)	P_13.12.144
Current Sense Amplifier DC Gain (uncalibrated)	$G_{DIFF40}$	39.53	40.05	40.57	V/V	CSAG = (1,0)	P_13.12.145
Current Sense Amplifier DC Gain (uncalibrated)	$G_{DIFF60}$	59.34	60.12	60.91	V/V	CSAG = (1,1)	P_13.12.146
Gain drift	$G_{DRIFT}$	-0.5	-	0.5	%	<sup>6)</sup> Gain drift after calibration	P_13.12.151
CSO single ended output voltage range (linear range)	$V_{CSO}$	0.5	-	$V_{CC1} - 0.5$	V	<sup>6)</sup>	P_13.12.152
Reference voltage for unidirectional CSAx	$V_{REF \text{ Unidir}}$	-1.25%	$V_{CC1}/5$	+1.25%	V	CSD = 0 $V_{CSAP} = V_{CSAN}$	P_13.12.153
Reference voltage for bidirectional CSAx	$V_{REF \text{ Bidir}}$	-1%	$V_{CC1}/2$	+1%	V	CSD = 1 $V_{CSAP} = V_{CSAN}$	P_13.12.154

**Overcurrent detection**

Overcurrent filter time	$t_{FOC}$	4 7 40 80	6 10 50 100	8 13 60 120	$\mu\text{s}$	<sup>5)6)</sup> OCFILT = 00 <sub>B</sub> OCFILT = 01 <sub>B</sub> OCFILT = 10 <sub>B</sub> OCFILT = 11 <sub>B</sub>	P_13.12.155
OC threshold, unidirectional	$V_{OCTH1 \text{ Unidir}}$	-4%	$V_{CC1}/2$	+4%	V	CSD = 0, OCTH[1:0] = 00 <sub>B</sub>	P_13.12.156
OC threshold, unidirectional	$V_{OCTH2 \text{ Unidir}}$	-4%	$V_{CC1}/2 + V_{CC1}/10$	+4%	V	CSD = 0, OCTH[1:0] = 01 <sub>B</sub>	P_13.12.157

**Supervision Functions**

**Table 35 Electrical Characteristics (cont'd)**

$V_{SINT} = 5.5 \text{ V to } 28 \text{ V}$ ;  $T_j = -40^\circ\text{C to } +175^\circ\text{C}$ ; Normal Mode; all voltages with respect to ground; positive current defined flowing into pin; unless otherwise specified.

Parameter	Symbol	Values			Unit	Note or Test Condition	Number
		Min.	Typ.	Max.			
OC threshold, unidirectional	$V_{OCTH3 \text{ Unidir}}$	-4%	$V_{CC1}/2 + 2x$ $V_{CC1}/10$	+4%	V	CSD = 0, OCTH[1:0]= 10 <sub>B</sub>	P_13.12.158
OC threshold, unidirectional	$V_{OCTH4 \text{ Unidir}}$	-4%	$V_{CC1}/2 + 3x$ $V_{CC1}/10$	+4%	V	CSD = 0, OCTH[1:0]= 11 <sub>B</sub>	P_13.12.159
High OC threshold, bidirectional	$V_{OCTH1 \text{ BidirH}}$	-4%	$V_{CC1}/2 + 2x$ $V_{CC1}/20$	+4%	V	CSD = 1, OCTH[1:0]= 00 <sub>B</sub>	P_13.12.160
High OC threshold, bidirectional	$V_{OCTH2 \text{ BidirH}}$	-4%	$V_{CC1}/2 + 4x$ $V_{CC1}/20$	+4%	V	CSD = 1, OCTH[1:0]= 01 <sub>B</sub>	P_13.12.161
High OC threshold, bidirectional	$V_{OCTH3 \text{ BidirH}}$	-4%	$V_{CC1}/2 + 5x$ $V_{CC1}/20$	+4%	V	CSD = 1, OCTH[1:0]= 10 <sub>B</sub>	P_13.12.162
High OC threshold, bidirectional	$V_{OCTH4 \text{ BidirH}}$	-4%	$V_{CC1}/2 + 6x$ $V_{CC1}/20$	+4%	V	CSD = 1, OCTH[1:0]= 11 <sub>B</sub>	P_13.12.163
Low OC threshold, bidirectional	$V_{OCTH1 \text{ BidirL}}$	-4%	$V_{CC1}/2 - 2x$ $V_{CC1}/20$	+4%	V	CSD = 1, OCTH[1:0]= 00 <sub>B</sub>	P_13.12.164
Low OC threshold, bidirectional	$V_{OCTH2 \text{ BidirL}}$	-4%	$V_{CC1}/2 - 4x$ $V_{CC1}/20$	+4%	V	CSD = 1, OCTH[1:0]= 01 <sub>B</sub>	P_13.12.165
Low OC threshold, bidirectional	$V_{OCTH3 \text{ BidirL}}$	-4%	$V_{CC1}/2 - 5x$ $V_{CC1}/20$	+4%	V	CSD = 1, OCTH[1:0]= 10 <sub>B</sub>	P_13.12.166
Low OC threshold, bidirectional	$V_{OCTH4 \text{ BidirL}}$	-4%	$V_{CC1}/2 - 6x$ $V_{CC1}/20$	+4%	V	CSD = 1, OCTH[1:0]= 11 <sub>B</sub>	P_13.12.167

**Current Sense Amplifier Dynamic Parameters**

Power Supply Rejection Ratio	PSRR	60	-	-	dB	<sup>6)</sup> VCP modulated with sinewave (100 kHz, 1 Vpp)	P_13.12.168
------------------------------	------	----	---	---	----	--	-------------

**Overtemperature Shutdown<sup>6)</sup>**

Thermal Prewarning Temperature	$T_{jPW}$	125	145	165	°C	$T_j$ rising	P_13.12.169
Thermal Shutdown TSD1	$T_{jTSD1}$	175	185	200	°C	$T_j$ rising	P_13.12.170
Thermal Shutdown TSD2	$T_{jTSD2}$	175	185	200	°C	$T_j$ rising	P_13.12.171

**Supervision Functions**

**Table 35 Electrical Characteristics** (cont'd)

$V_{SINT} = 5.5 \text{ V to } 28 \text{ V}$ ;  $T_j = -40^\circ\text{C to } +175^\circ\text{C}$ ; Normal Mode; all voltages with respect to ground; positive current defined flowing into pin; unless otherwise specified.

Parameter	Symbol	Values			Unit	Note or Test Condition	Number
		Min.	Typ.	Max.			
Thermal Shutdown hysteresis	$T_{jTSD,hys}$	–	25	–	°C	6)	P_13.12.172
TSD/TPW Filter Time	$t_{TSD\_TPW\_F}$	5	10	15	us	rising and falling, applies to all thermal sensors (TPW, TSD1, TSD2)	P_13.12.173
Deactivation time after thermal shutdown TSD2	$t_{TSD2}$	0.8	1	1.2	s	2)	P_13.12.174

1) It is ensured that the threshold  $V_{CC1,OV,r}$  is always higher than the highest regulated  $V_{CC1}$  output voltage  $V_{CC1,out4}$ .

2) Not subject to production test, tolerance defined by internal oscillator tolerance.

3) This time applies for all failure entries except a device thermal shutdown (TSD2 has a typ. 1 s waiting time  $t_{TSD2}$ ).

4)  $6 \text{ V} \leq V_S \leq 23 \text{ V}$

5)  $t_{FOC}$  refers to the output of the current sense amplifier. The CSO settling time ( $2 \mu\text{s max, } t_{SET}$ ) and the analog propagation delay ( $< 1 \mu\text{s}$ ) are not taken into account by the overcurrent filter time.

6) Not subject to production test, specified by design.

Serial Peripheral Interface

## 11 Serial Peripheral Interface

The Serial Peripheral Interface is the communication link between the device and the microcontroller. The TLE9185QXW is supporting multi-slave operation in full-duplex mode with 32-bit data access.

The SPI behavior for the different device modes is as follows:

- The SPI is enabled in Init Mode, Normal Mode and Stop Mode.
- The SPI is OFF in Sleep Mode, Restart Mode and Fail-Safe Mode.

### 11.1 SPI Block Description

The Control Input Word is read via the data input SDI, which is synchronized with the clock input CLK provided by the microcontroller. The output word appears synchronously at the data output SDO (see [Figure 56](#) with a 32-bit data access example).

The transmission cycle begins when the chip is selected by the input CSN (Chip Select Not), LOW active. After the CSN input returns from LOW to HIGH, the word that has been read is interpreted according to the content. The SDO output switches to tristate status (high impedance) at this point, thereby releasing the SDO bus for other use. The state of SDI is shifted into the input register with every falling edge on CLK. The state of SDO is shifted out of the output register after every rising edge on CLK. The SPI of the device is not daisy chain capable.

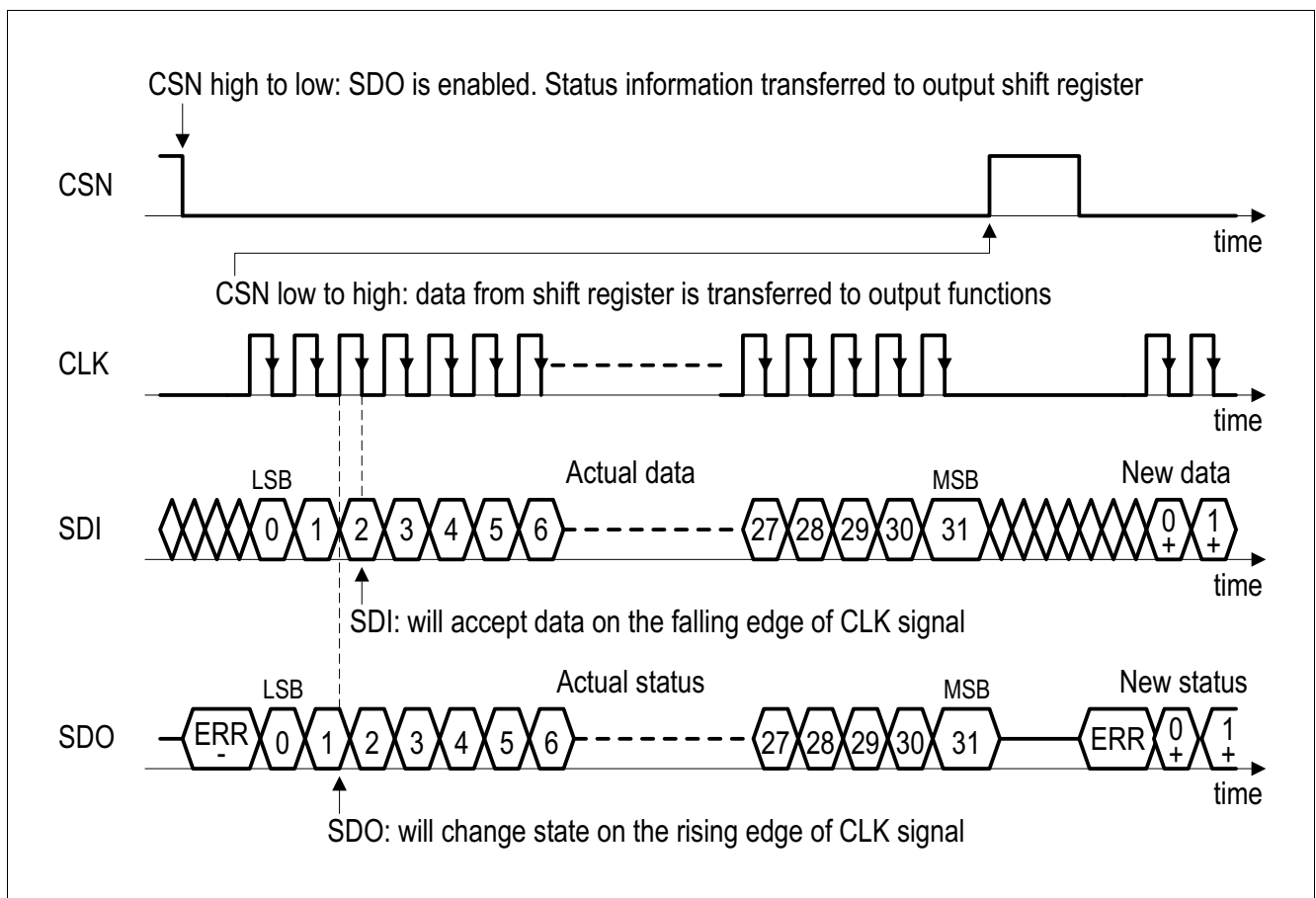

**Figure 56 SPI Data Transfer Timing (note the reversed order of LSB and MSB shown in this figure compared to the register description)**

## 11.2 Failure Signalization in the SPI Data Output

When the microcontroller sends a wrong SPI command to the device, the device ignores the information. Wrong SPI commands are either invalid device mode commands or commands which are prohibited by the state machine to avoid undesired device or system states (see below). In this case the diagnosis bit **SPI\_FAIL** is set and the SPI Write command is ignored (no partial interpretation). This bit can be only reset by actively clearing it via a SPI command.

**Invalid SPI Commands leading to SPI\_FAIL are listed below (in this case the SPI command is ignored):**

- Illegal state transitions:
  - Going from Stop Mode to Sleep Mode. In this case the device enters Restart Mode.
  - Trying to go to Stop Mode or Sleep Mode from Init Mode<sup>1)</sup>. In this case Normal Mode is entered.
- Uneven parity in the data bit of the **WD\_CTRL** register. In this case the watchdog trigger is ignored and/or the new watchdog settings are ignored respectively.
- In Stop Mode: attempting to change any SPI settings, e.g. changing the watchdog configuration is ignored; only WD trigger, returning to Normal Mode, triggering a device soft reset, and read & clear status registers commands are valid SPI commands in Stop Mode; **Note:** No failure handling is done for the attempt to go to Stop Mode when all bits in the register **WK\_CTRL** is cleared because the microcontroller can leave this mode via SPI.
- When entering Stop Mode and **WK\_STAT** is not cleared; **SPI\_FAIL** will not be set but the INTN pin will be triggered.
- Changing from Stop Mode to Normal Mode and changing the other bits of the **M\_S\_CTRL** register. The other modifications will be ignored.
- Sleep Mode: attempt to go to Sleep Mode without any wake source set, i.e. when all bits in the **WK\_CTRL** register is cleared. In this case the **SPI\_FAIL** bit is set and the device enters Restart Mode. Even though the Sleep Mode command is not entered in this case, the rest of the command is executed but restart values apply during Restart Mode; **Note:** At least one wake source must be activated in order to avoid a deadlock situation in Sleep Mode. If the only wake source is a timer and the timer is OFF, then the device will wake immediately from Sleep Mode and enter Restart Mode.
- Setting a longer or equal on-time than the timer period of the respective timer.
- SDI stuck at HIGH or LOW, e.g. SDI received all '0' or all '1'.

*Note: There is no SPI fail information for unused addresses.*

*Note: In case that the register or banking are accessed but they are not valid as address or banks, the **SPI\_FAIL** is not triggered and the cmd is ignored.*

### **Signalization of the ERR Flag (high active) in the SPI Data Output (see Figure 56):**

The ERR flag presents an additional diagnosis possibility for the SPI communication. The ERR flag is being set for following conditions:

- in case the number of received SPI clocks is not 0 or 32.
- in case RSTN is LOW and SPI frames are being sent at the same time.

1) If the device is externally configured to use SPI with CRC (by PWM1/CRC pin), the attempt to go to Stop or Sleep from Init, will generate SPI\_FAIL even if it is a SPI command with correct CRC. Still, the first SPI command will put the device from Init to Normal Mode even if CRC is not correct (CRC\_FAIL status bit will be set).



## Serial Peripheral Interface

*Note: In order to read the SPI ERR flag properly, CLK must be low when CSN is triggered, i.e. the ERR bit is not valid if the CLK is high on a falling edge of CSN.*

### **The number of received SPI clocks is not 0 or 32:**

The number of received input clocks is supervised to be 0 or 32 clock cycles and the input word is discarded in case of a mismatch (0 clock cycle to enable ERR signalization). The error logic also recognizes if CLK was high during CSN edges. Both errors ( 0 or 32 bit CLK mismatch or CLK high during CSN edges ) are flagged in the following SPI output by a “HIGH” at the data output (SDO pin, bit ERR) before the first rising edge of the clock is received. The complete SPI command is ignored in this case.

### **RSTN is LOW and SPI frames are being sent at the same time:**

The ERR flag will be set when the RSTN pin is triggered (during device restart) and SPI frames are being sent to the device at the same time. The behavior of the ERR flag will be signalized at the next SPI command for below conditions:

- If the command begins when RSTN is HIGH and it ends when RSTN is LOW.
- If a SPI command will be sent while RSTN is LOW.
- If a SPI command begins when RSTN is LOW and it ends when RSTN is HIGH.

And the SDO output will behave as follows:

- Always when RSTN is LOW then SDO will be HIGH.
- When a SPI command begins when RSTN is LOW and ends when RSTN is HIGH, then the SDO should be ignored because wrong data will be sent.

*Note: It is possible to quickly check for the ERR flag without sending any data bits. i.e. only the CSN is pulled low and SDO is observed - no SPI Clocks are sent in this case.*

*Note: The ERR flag could also be set after the device has entered Fail-Safe Mode because the SPI communication is stopped immediately.*

**Serial Peripheral Interface**

**11.3 SPI Programming**

For the TLE9185QXW, 7 bits are used for the address selection (BIT 6...0). Bit 7 is used to decide between Read Only and Read & Clear for the status bits, and between Write and Read Only for configuration bits. For the actual configuration and status information, 16 data bits (BIT 23...8) are used.

Writing, clearing and reading is done word wise. The SPI status bits are not cleared automatically and must be cleared by the microcontroller. Some of the configuration bits will automatically be cleared by the device (refer to the respective register descriptions for detailed information). In Restart Mode, the device ignores all SPI communication, i.e. it does not interpret it.

There are two types of SPI registers:

- Control registers: These registers are used to configure the device, e.g. mode, watchdog trigger, etc.
- Status registers: These registers indicate the status of the device, e.g. wake events, warnings, failures, etc.

For the status registers, the requested information is given in the same SPI command in the data out (SDO). For the control registers, the status of each byte is shown in the same SPI command as well. However, configuration changes of the same register are only shown in the next SPI command (configuration changes inside the device become valid only after CSN changes from low to high). See [Figure 57](#).

Writing of control registers is possible in Init and Normal Mode. During Stop Mode only the change to Normal Mode and triggering the watchdog is allowed as well as reading and clearing the status registers.

No status information can be lost, even if a bit changes right after the first 7 SPI clock cycles before the SPI frame ends. In this case the status information field will be updated with the next SPI command. However, the flag is already set in the relevant status register. The device status information from the SPI status registers is transmitted in a compressed format with each SPI response on SDO in the so-called Status Information Field register (see also [Table 36](#)). The purpose of this register is to quickly signal changes in dedicated SPI status registers to the microcontroller.

**Table 36 Status Information Field**

Bit in Status Information Field	Corresponding Address Bit	Status Register Description
0		SUPPLY_STAT = OR of all bits on SUP_STAT register
1		TEMP_STAT = OR of all bits on THERM_STAT register
2		Reserved
3		WAKE_UP = OR of all bits on WK_STAT register
4		Reserved
5		DEV_STAT = OR of all bits on DEV_STAT except CRC_STAT and SW_DEV
6		BD_STAT = OR of all bits on DSOV register
7		SPI_CRC_FAIL = (SPI_FAIL) OR (CRC_FAIL)

Serial Peripheral Interface

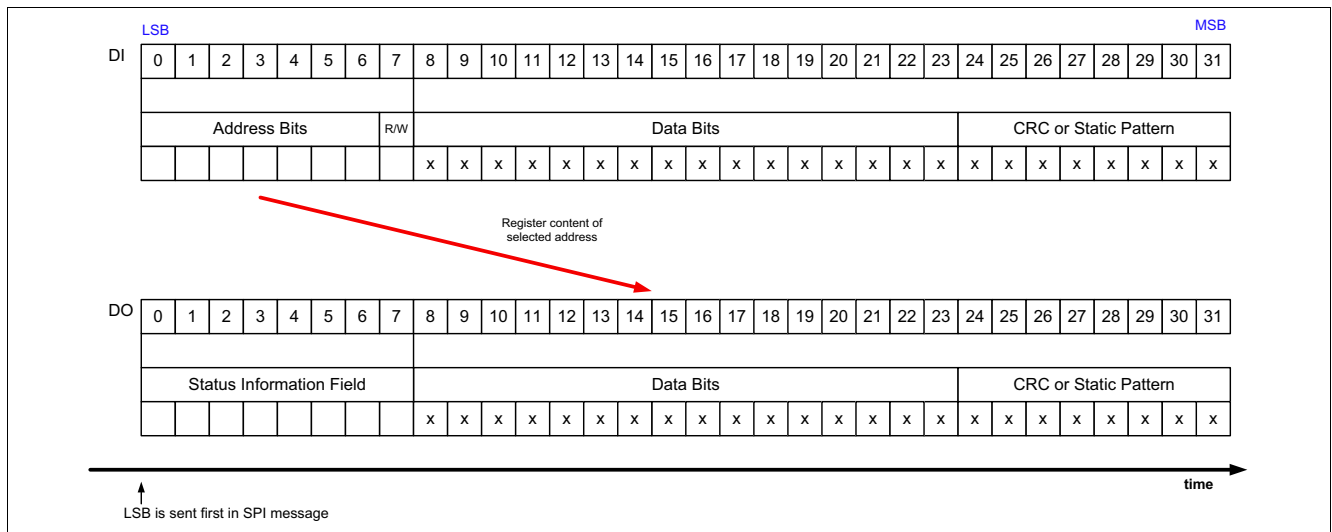

Figure 57 SPI Operation Mode

11.3.1 CRC

The SPI interface includes also 8 Bits (bits 24 to 31) used for Cyclic Redundancy Check (CRC) to ensure data integrity on sent or received SPI command.

The implemented CRC is based on Autosar specification of CRC Routines revision 4.3.0 and in particular the function CRC8-2FH.

The specification are based on the follow table:

Table 37 CRC8x2FH definition

CRC result width:	8 bits
Polynomial	2F <sub>H</sub>
Initial Value	FF <sub>H</sub>
Input data reflected	No
Result data reflected	No
XOR value	FF <sub>H</sub>
Check	DF <sub>H</sub>
Magic check	42 <sub>H</sub>

Some examples of CRC calculation are shown in the follow table:

Table 38 CRC8x2FH calculation example

Data Bytes (hexadecimal)									CRC
00	00	00	00						12
F2	01	83							C2
0F	AA	00	55						C6
00	FF	55	11						77
33	22	55	AA	BB	CC	DD	EE	FF	11
92	6B	55							33
FF	FF	FF	FF						6C

## Serial Peripheral Interface

### Polynomial

The polynomial is:

$$x^8 + x^5 + x^3 + x^2 + x^1 + x^0 \quad (11.1)$$

### Calculation in SDI and SDO

The calculation of the CRC is done considering the first 24 bits (BIT 0..23) either of SDI or SDO.

The content of SDO Payload (BIT 8..23) is referring the previous data written at the addressed register via SDI.

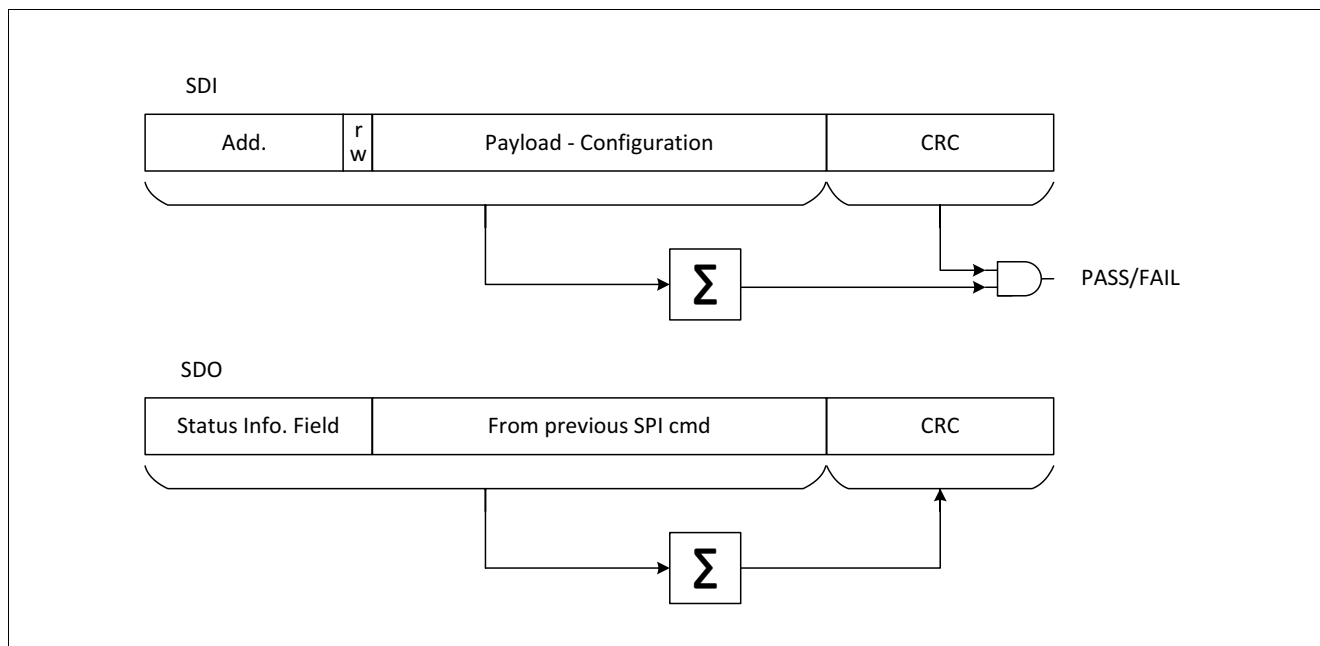

**Figure 58** CRC calculation

### CRC Activation and status information

For CRC activation, refer to [Chapter 5.2](#).

The CRC status ([CRC\\_STAT](#)) and failure ([CRC\\_FAIL](#)) are readable on [DEV\\_STAT](#).

Read out of the register which contains the [CRC\\_STAT](#) and [CRC\\_FAIL](#) is done ignoring the CRC field and no failure flag are set.

The [DEV\\_STAT](#) register shall be cleared considering the CRC setting (ON or OFF).

The [CRC\\_STAT](#) bit is read only.

The [CRC\\_FAIL](#) is set in the follow conditions:

- If the CRC is enabled and the  $\mu\text{C}$  sends wrong CRC field.
- If the CRC is disabled and the  $\mu\text{C}$  sends wrong static pattern (no  $A5_H$ ).

### CRC field in case of CRC disabled

In case that the CRC is not activated, the bits needed for CRC field have to be filled with static pattern.

In case of SDI, the CRC field has to be filled with  $A5_H$  (bits 24:31).

In case of SDO, the device will always answer with  $5A_H$  (bits 24:31).

The status of the CRC is updated accordingly in [CRC\\_STAT](#) bit.

## Serial Peripheral Interface

### 11.4 SPI Bit Mapping

The following figures show the mapping of the registers and the SPI bits of the respective registers.

The Control Registers are Read/Write Register with the following structure:

- Device Control Registers from 000 0001<sub>B</sub> to 000 1011<sub>B</sub>.
- Bridge Driver Control Registers from 001 0000<sub>B</sub> to 001 1101<sub>B</sub>.

Depending on bit 7 the bits are only read (setting bit 7 to '0') or also written (setting bit 7 to '1'). The new setting of the bit after a write can be seen with a new read / write command.

The Status Registers are Read/Clear with the following structure:

- Device Status Registers from 100 0000<sub>B</sub> to 100 0110<sub>B</sub>.
- Bridge Driver Status Registers from 101 0000<sub>B</sub> to 101 1011<sub>B</sub>.
- Product Family is 111 0000<sub>B</sub>.

The registers can be read or can be cleared (if clearing is possible) depending on bit 7. To clear the payload of one of the Status Registers bit 7 must be set to 1.

The registers **WK\_LVL\_STAT**, and **FAM\_PROD\_STAT** are an exception as they show the actual voltage level at the respective WKx pin (LOW/HIGH), or a fixed family/ product ID respectively and can thus not be cleared. It is recommended for proper diagnosis to clear respective status bits for wake events or failure.

When changing to a different device mode, certain configurations bits will be cleared automatically or modified:

- The device mode bits are updated to the actual status, e.g. when returning to Normal Mode.
- When changing to a low-power mode (Stop Mode or Sleep Mode), the diagnosis bits of the integrated module are not cleared.
- When changing to Stop Mode, the control bits will not be modified.
- When changing to Sleep Mode, the control bits will be modified if they were not OFF or wake capable before.

*Note: The detailed behavior of the respective SPI bits and control functions is described in [Chapter 11.5](#), [Chapter 11.6](#) and in the respective module chapter. The bit type be marked as 'rwh' in case the device will modify respective control bits.*

Serial Peripheral Interface

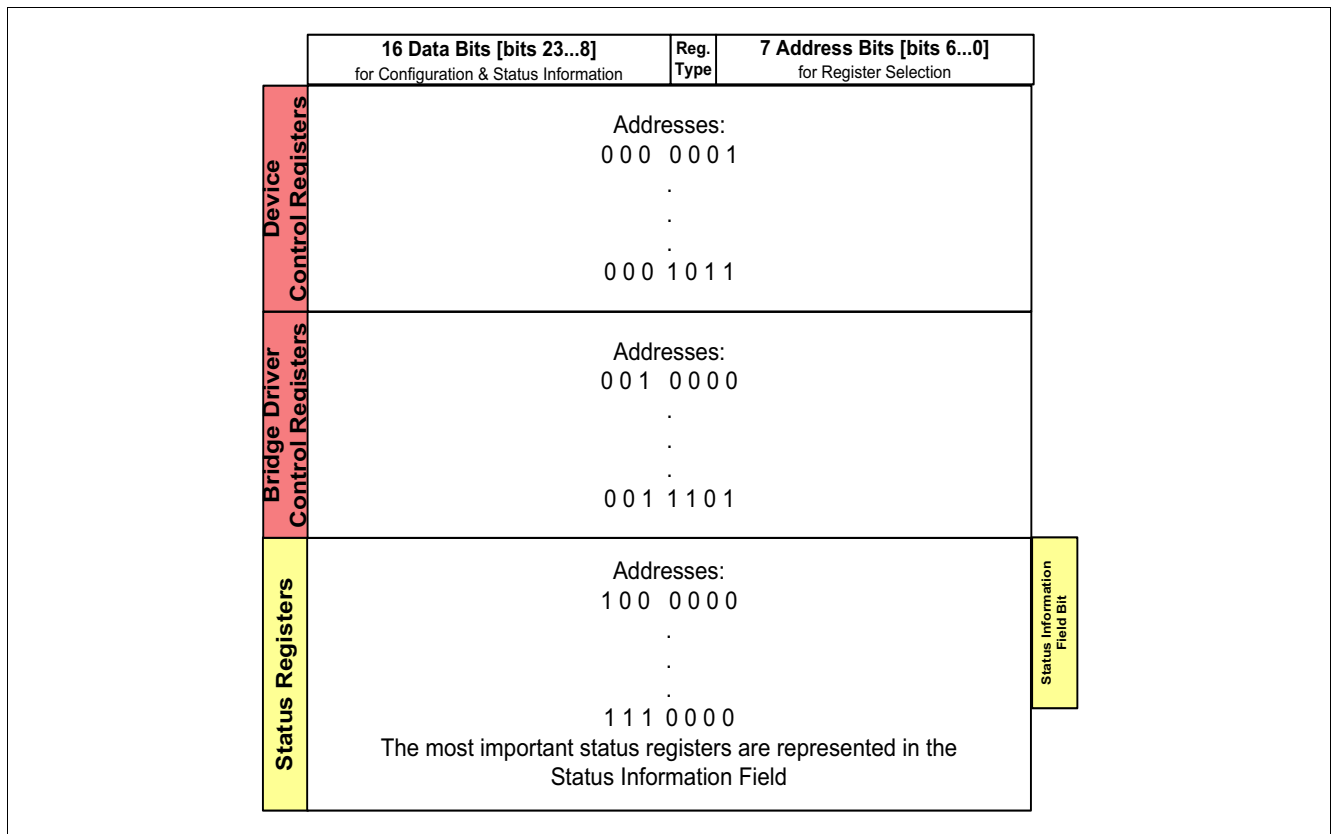

Figure 59 SPI Register Mapping Structure

The detailed register mappings for control registers and status registers are shown in [Table 39](#) and [Table 61](#) respectively.

### 11.4.1 Register Banking

In order to minimize the number of configuration registers, seven registers follow a bank structure.

The banked registers are:

- [WK\\_CTRL](#)
- [CCP\\_BLK](#)
- [TPRECHG](#)
- [HB\\_ICHG](#)
- [HB\\_PCHG\\_INIT](#)
- [TDON\\_HB\\_CTRL](#)
- [TDOFF\\_HB\\_CTRL](#)

In these register, the first 3 bits of the payload (bit 8 to 10) select the bank that has to be configured. The rest of the payload is used to configure the selected bank (for more details refer to the specific banked register).

In case that CRC is used, the CRC calculation is done considering the first 24 bits (from bit 0 to 23).

The banked registers can be read like the other configuration registers but in the SDO one '0' is automatically added after the status information field. [Figure 60](#) shows the structure of SDO in banked register.

Serial Peripheral Interface

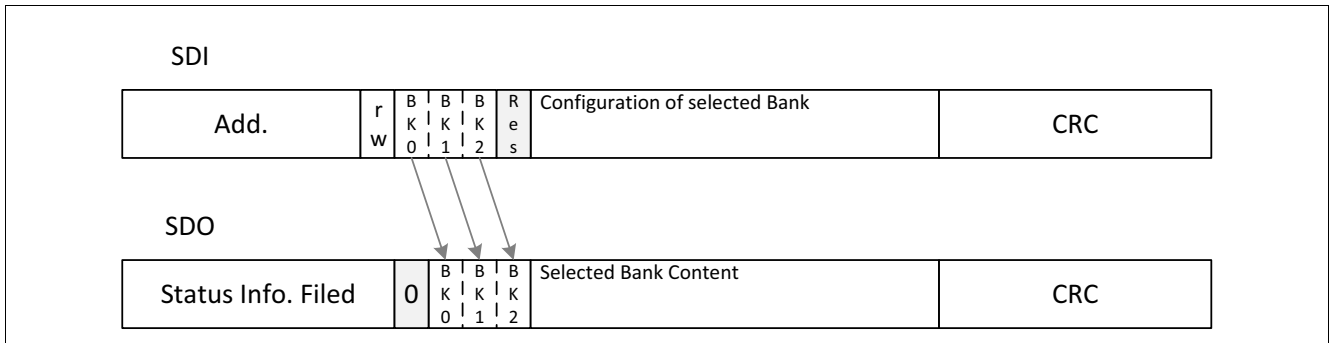

Figure 60 Register read Out of banked register (3 bit banking)

**Serial Peripheral Interface**

**11.5 SPI control registers**

READ/WRITE Operation (see also [Chapter 11.3](#)):

- The ‘POR / Soft Reset Value’ defines the register content after POR or device reset.
- The ‘Restart Value’ defines the register content after device restart, where ‘x’ means the bit is unchanged.
- There are different bit types:
  - ‘r’ = READ: read only bits (or reserved bits).
  - ‘rw’ = READ/WRITE: readable and writable bits.
  - ‘rwh’ = READ/WRITE/Hardware: readable/writable bits, which can also be modified by the device hardware.
- Reserved bits are marked as “Reserved” and always read as “0”. The respective bits shall also be programmed as “0”.
- Reading a register is done word wise by setting the SPI bit 7 to “0” (= Read Only).
- SPI control bits are in general not cleared or changed automatically. This must be done by the microcontroller via SPI programming. Exceptions to this behavior are stated at the respective register description and the respective bit type is marked with a ‘h’ meaning that the device is able to change the register content.

The registers are addressed wordwise.

**Table 39 Register Overview**

Register Short Name	Register Long Name	Offset Address	Page Number
<b>SPI control registers, Device Control Registers</b>			
<a href="#">M_S_CTRL</a>	Mode and Supply Control	0000001 <sub>B</sub>	<a href="#">130</a>
<a href="#">HW_CTRL</a>	Hardware Control	0000010 <sub>B</sub>	<a href="#">132</a>
<a href="#">WD_CTRL</a>	Watchdog Control	0000011 <sub>B</sub>	<a href="#">134</a>
<a href="#">WK_CTRL</a>	Wake-up Control	0000101 <sub>B</sub>	<a href="#">135</a>
<a href="#">TIMER_CTRL</a>	Timer 1 and Timer 2 Control and Selection	0000110 <sub>B</sub>	<a href="#">137</a>
<a href="#">INT_MASK</a>	Interrupt Mask Control	0001001 <sub>B</sub>	<a href="#">139</a>
<a href="#">SYS_STAT_CTRL</a>	System Status Control	0001011 <sub>B</sub>	<a href="#">141</a>
<b>SPI control registers, Control registers bridge driver</b>			
<a href="#">GENCTRL</a>	General Bridge Control	0010000 <sub>B</sub>	<a href="#">142</a>
<a href="#">CSA</a>	Current sense amplifier	0010001 <sub>B</sub>	<a href="#">144</a>
<a href="#">LS_VDS</a>	Drain-Source monitoring threshold	0010010 <sub>B</sub>	<a href="#">146</a>
<a href="#">HS_VDS</a>	Drain-Source monitoring threshold	0010011 <sub>B</sub>	<a href="#">148</a>
<a href="#">CCP_BLK</a>	CCP and times selection	0010100 <sub>B</sub>	<a href="#">150</a>
<a href="#">HBMODE</a>	Half-Bridge MODE	0010101 <sub>B</sub>	<a href="#">151</a>
<a href="#">TPRECHG</a>	PWM pre-charge and pre-discharge time	0010110 <sub>B</sub>	<a href="#">153</a>
<a href="#">ST_ICHG</a>	Static charge/discharge current	0010111 <sub>B</sub>	<a href="#">154</a>
<a href="#">HB_ICHG</a>	PWM charge/discharge current	0011000 <sub>B</sub>	<a href="#">155</a>
<a href="#">HB_ICHG_MAX</a>	PWM max. pre-charge/pre-discharge current and diagnostic pull-down	0011001 <sub>B</sub>	<a href="#">156</a>
<a href="#">HB_PCHG_INIT</a>	PWM pre-charge/pre-discharge initialization	0011010 <sub>B</sub>	<a href="#">158</a>



Serial Peripheral Interface

Table 39 Register Overview (cont'd)

Register Short Name	Register Long Name	Offset Address	Page Number
<a href="#">TDON_HB_CTRL</a>	PWM inputs TON configuration	0011011 <sub>B</sub>	<a href="#">159</a>
<a href="#">TDOFF_HB_CTRL</a>	PWM inputs TOFF configuration	0011100 <sub>B</sub>	<a href="#">160</a>
<a href="#">BRAKE</a>	Brake control	0011101 <sub>B</sub>	<a href="#">161</a>

Serial Peripheral Interface

### 11.5.1 Device Control Registers

#### Mode and Supply Control

##### M\_S\_CTRL

##### Mode and Supply Control

(000 0001<sub>B</sub>)

Reset Value: see [Table 40](#)

15	14	13	12	11	10	9	8	7	6	5	4	3	2	1	0
MODE		RES			VCC1_OV_MOD		RES	RSTN_HYS	RES	I_PEAK_TH	RES			VCC1_RT	
rwh		r			rwh		r	rw	r	rw	r			rw	

Field	Bits	Type	Description
MODE	15:14	rwh	<b>Device Mode Control</b> 00 <sub>B</sub> <b>NORMAL</b> , Normal Mode 01 <sub>B</sub> <b>SLEEP</b> , Sleep Mode 10 <sub>B</sub> <b>STOP</b> , Stop Mode 11 <sub>B</sub> <b>RESET</b> , Device reset: Soft reset is executed (configuration of RSTN triggering in bit <a href="#">SOFT_RESET_RO</a> )
RES	13:11	r	<b>Reserved, always reads as 0</b>
VCC1_OV_MOD	10:9	rwh	<b>Reaction in case of VCC1 Over Voltage</b> 00 <sub>B</sub> <b>NO</b> , no reaction 01 <sub>B</sub> <b>INTN</b> , INTN event is generated 10 <sub>B</sub> <b>RSTN</b> , RSTN event is generated 11 <sub>B</sub> <b>FAILSAFE</b> , Fail-Safe Mode is entered
RES	8	r	<b>Reserved, always reads as 0</b>
RSTN_HYS	7	rw	<b>VCC1 Undervoltage Reset Hysteresis Selection (see also <a href="#">Chapter 10.6.1</a> for more information)</b> 0 <sub>B</sub> <b>DEFAULT</b> , default hysteresis applies as specified in the electrical characteristics table 1 <sub>B</sub> <b>HIGHEST</b> , the highest rising threshold (VRT1,R) is always used for the release of the undervoltage reset
RES	6	r	<b>Reserved, always reads as 0</b>
I_PEAK_TH	5	rw	<b>VCC1 Active Peak Threshold Selection</b> 0 <sub>B</sub> <b>LOW</b> , low VCC1 active peak threshold selected 1 <sub>B</sub> <b>HIGH</b> , high VCC1 active peak threshold selected
RES	4:2	r	<b>Reserved, always reads as 0</b>
VCC1_RT	1:0	rw	<b>VCC1 Reset Threshold Control</b> 00 <sub>B</sub> <b>VRT1</b> , Vrt1 selected (highest threshold) 01 <sub>B</sub> <b>VRT2</b> , Vrt2 selected 10 <sub>B</sub> <b>VRT3</b> , Vrt3 selected 11 <sub>B</sub> <b>VRT4</b> , Vrt4 selected

---

Serial Peripheral Interface

**Table 40** Reset of **M\_S\_CTRL**

Register Reset Type	Reset Values	Reset Short Name	Reset Mode	Note
POR/Soft reset	0000 0000 0000 0000 <sub>B</sub>			
Restart	0000 0000 x0x0 00xx <sub>B</sub>			

**Notes**

1. It is not possible to change from Stop Mode to Sleep Mode via SPI Command. See also the State Machine Chapter.
2. After entering Restart Mode, the MODE bits will be automatically set to Normal Mode.
3. The SPI output will always show the previously written state with a Write Command (what has been programmed before).

Serial Peripheral Interface

Hardware Control

HW\_CTRL

Hardware Control

(000 0010<sub>B</sub>)

Reset Value: see [Table 41](#)

15	14	13	12	11	10	9	8	7	6	5	4	3	2	1	0
RES		TSD2_DEL	VS_OV_SEL	SH_DISABLE	RSTN_DEL	RES		SOFT_RESET_RO	RES	RES		WD_STM_EN_1	RES		
r		rw	rw	rw	rw	r		rw	r	r		rwh	r		

Field	Bits	Type	Description
RES	15:13	r	<b>Reserved, always reads as 0</b>
TSD2_DEL	12	rw	<b>TSD2 minimum Waiting Time Selection</b> 0 <sub>B</sub> <b>1s</b> , Minimum waiting time until TSD2 is released again is always 1 s 1 <sub>B</sub> <b>64s</b> , Minimum waiting time until TSD2 is released again is 1 s, after >16 TSD2 consecutive events, it will extended x 64
VS_OV_SEL	11	rw	<b>VS OV comparator threshold change</b> 0 <sub>B</sub> <b>20V</b> , Default threshold setting ( $V_{S,OVD1}$ ) 1 <sub>B</sub> <b>30V</b> , increased threshold setting ( $V_{S,OVD2}$ )
SH_DISABLE	10	rw	<b>Sample and hold circuitry disable</b> 0 <sub>B</sub> <b>ENABLED</b> , Gate driver S&H circuitry enabled 1 <sub>B</sub> <b>DISABLED</b> , Gate driver S&H circuitry disabled
RSTN_DEL	9	rw	<b>Reset delay time</b> 0 <sub>B</sub> <b>10ms</b> , Reset delay time 10 ms ( $t_{RD1}$ ) 1 <sub>B</sub> <b>2ms</b> , Reset delay time to 2 ms ( $t_{RD2}$ )
RES	8:7	r	<b>Reserved, always reads as 0</b>
SOFT_RESET_RO	6	rw	<b>Soft Reset Configuration</b> 0 <sub>B</sub> <b>RSTN</b> , RSTN will be triggered (pulled low) during a Soft Reset 1 <sub>B</sub> <b>NO_RSTN</b> , no RSTN trigger during a Soft Reset
RES	5	r	<b>Reserved, always reads as 0</b>
RES	4:3	r	<b>Reserved, always reads as 0</b>
WD_STM_EN_1	2	rwh	<b>Watchdog Deactivation during Stop Mode, bit1</b> 0 <sub>B</sub> <b>ACTIVE</b> , Watchdog is active in Stop Mode 1 <sub>B</sub> <b>INACTIVE</b> , Watchdog is deactivated in Stop Mode
RES	1:0	r	<b>Reserved, always reads as 0</b>

**Table 41** Reset of **HW\_CTRL**

Register Reset Type	Reset Values	Reset Short Name	Reset Mode	Note
POR	0000 0000 0000 0000 <sub>B</sub>			
Soft reset	0000 00x0 0000 0000 <sub>B</sub>			
Restart	000x 00x0 0x00 0000 <sub>B</sub>			

---

**Serial Peripheral Interface**

**Notes**

1. *WD\_STM\_EN\_1 will also be cleared when changing from Stop Mode to Normal Mode .*

Serial Peripheral Interface

Watchdog Control

WD\_CTRL

Watchdog Control

(000 0011<sub>B</sub>)

Reset Value: see [Table 42](#)

15	14	13	12	11	10	9	8	7	6	5	4	3	2	1	0
CHEC KSUM		RES					WD_S TM_E N_0		WD_C FG	RES	RES	WD_TIMER			
rw		r					rwh		rw	rwh	r	rwh			

Field	Bits	Type	Description
CHECKSUM	15	rw	<b>Watchdog Setting Check Sum Bit</b> 0 <sub>B</sub> 0, Counts as 0 for checksum calculation 1 <sub>B</sub> 1, Counts as 1 for checksum calculation
RES	14:7	r	<b>Reserved, always reads as 0</b>
WD_STM_EN_0	6	rwh	<b>Watchdog Deactivation during Stop Mode, bit0</b> 0 <sub>B</sub> <b>ACTIVE</b> , Watchdog is active in Stop Mode 1 <sub>B</sub> <b>INACTIVE</b> , Watchdog is deactivated in Stop Mode
WD_CFG	5	rw	<b>Watchdog Configuration</b> 0 <sub>B</sub> <b>TIMEOUT</b> , Watchdog works as a Time-Out watchdog 1 <sub>B</sub> <b>WINDOW</b> , Watchdog works as a Window watchdog
RES	4	rwh	<b>Reserved, to be set to '0'</b>
RES	3	r	<b>Reserved, always reads as 0</b>
WD_TIMER	2:0	rwh	<b>Watchdog Timer Period</b> 000 <sub>B</sub> <b>10ms</b> , 10ms 001 <sub>B</sub> <b>20ms</b> , 20ms 010 <sub>B</sub> <b>50ms</b> , 50ms 011 <sub>B</sub> <b>100ms</b> , 100ms 100 <sub>B</sub> <b>200ms</b> , 200ms 101 <sub>B</sub> <b>500ms</b> , 500ms 110 <sub>B</sub> <b>1s</b> , 1s 111 <sub>B</sub> <b>10s</b> , 10s

Table 42 Reset of **WD\_CTRL**

Register Reset Type	Reset Values	Reset Short Name	Reset Mode	Note
POR/Soft reset	0000 0000 0001 0100 <sub>B</sub>			
Restart	0000 0000 000x 0100 <sub>B</sub>			

Notes

1. See also [Chapter 10.2.4](#) for more information on disabling the watchdog in Stop Mode.
2. See chapter [Chapter 10.2.3](#) for calculation of checksum.

Serial Peripheral Interface

Wake-up Control

WK\_CTRL

Wake-up Control

(000 0101<sub>B</sub>)

Reset Value: see [Table 43](#)

15	14	13	12	11	10	9	8	7	6	5	4	3	2	1	0
RES	RES	WK_FILT		WK_PUPD		RES	WK_EN		RES	WK_BNK					
r	r	rw		rw		r	rw		r	rw					

Field	Bits	Type	Description
RES	15	r	<b>Reserved, always reads as 0</b>
RES	14	r	<b>Reserved, always reads as 0</b>
WK_FILT	13:11	rw	<b>Wake-up Filter Time Configuration</b> 000 <sub>B</sub> <b>16us</b> , Filter with 16 μs filter time (static sensing) 001 <sub>B</sub> <b>64us</b> , Filter with 64 μs filter time (static sensing) 010 <sub>B</sub> <b>TIMER1</b> , Filtering at the end of the on-time; filter time of 16 μs (cyclic sensing) is selected, Timer1 011 <sub>B</sub> <b>TIMER2</b> , Filtering at the end of the on-time; filter time of 16 μs (cyclic sensing) is selected, Timer2 100 <sub>B</sub> , reserved 101 <sub>B</sub> , reserved 110 <sub>B</sub> , reserved 111 <sub>B</sub> , reserved
WK_PUPD	10:9	rw	<b>WKx Pull-Up/Pull-Down Configuration</b> 00 <sub>B</sub> <b>NO</b> , No pull-up/pull-down selected 01 <sub>B</sub> <b>PULL_DOWN</b> , Pull-down resistor selected 10 <sub>B</sub> <b>PULL_UP</b> , Pull-up resistor selected 11 <sub>B</sub> <b>AUTO</b> , Automatic switching to pull-up or pull-down
RES	8:7	r	<b>Reserved, always reads as 0</b>
WK_EN	6:5	rw	<b>WKx Enable ,to be set to 01B<sup>1)</sup></b> 00 <sub>B</sub> <b>WK_OFF</b> , WKx module OFF 01 <sub>B</sub> <b>WK_ON</b> , WKx module ON 10 <sub>B</sub> <b>RES</b> , reserved 11 <sub>B</sub> <b>OFF</b> , OFF
RES	4:3	r	<b>Reserved, always reads as 0</b>
WK_BNK	2:0	rw	<b>WKs input Banking, to be set to 011B</b> 011 <sub>B</sub> <b>WK4</b> , WK4 Module (Bank 4) 100 <sub>B</sub> , reserved 101 <sub>B</sub> , reserved 110 <sub>B</sub> , reserved 111 <sub>B</sub> , reserved

1) Warning: if WK\_EN is not set to 01<sub>B</sub>, then the device cannot wake up upon an edge of WK4.

---

Serial Peripheral Interface

**Table 43** Reset of **WK\_CTRL**

Register Reset Type	Reset Values	Reset Short Name	Reset Mode	Note
POR/Soft reset	0000 0000 0010 0000 <sub>B</sub>			
Restart	00xx xxx0 0xx0 0000 <sub>B</sub>			

**Notes**

1. At Fail-Safe Mode entry **WK\_EN** will be automatically changed (by the device) in “01”.
2. During Fail-Safe Mode the **WK\_FILT** bits are ignored and static-sense with 16  $\mu$ s filter time is used by default.



Serial Peripheral Interface

Timer 1 and Timer2 Control and Selection

TIMER\_CTRL

Timer 1 and Timer2 Control and Selection (000 0110<sub>B</sub>)

Reset Value: see [Table 44](#)

15	14	13	12	11	10	9	8	7	6	5	4	3	2	1	0
TIMER2_ON			RES	TIMER2_PER			CYCWK		TIMER1_ON			RES	TIMER1_PER		
rwh			r	rwh			rwh		rwh			r	rwh		

Field	Bits	Type	Description
TIMER2_ON	15:13	rwh	<b>Timer2 On-Time Configuration</b> 000 <sub>B</sub> <b>OFF</b> , OFF 001 <sub>B</sub> <b>100us</b> , 0.1ms on-time 010 <sub>B</sub> <b>300us</b> , 0.3ms on-time 011 <sub>B</sub> <b>1ms</b> , 1.0ms on-time 100 <sub>B</sub> <b>10ms</b> , 10ms on-time 101 <sub>B</sub> <b>20ms</b> , 20ms on-time 110 <sub>B</sub> , reserved 111 <sub>B</sub> , reserved
RES	12	r	<b>Reserved, always reads as 0</b>
TIMER2_PER	11:9	rwh	<b>Timer2 Period Configuration</b> 000 <sub>B</sub> <b>10ms</b> , 10ms 001 <sub>B</sub> <b>20ms</b> , 20ms 010 <sub>B</sub> <b>50ms</b> , 50ms 011 <sub>B</sub> <b>100ms</b> , 100ms 100 <sub>B</sub> <b>200ms</b> , 200ms 101 <sub>B</sub> <b>500ms</b> , 500ms 110 <sub>B</sub> <b>1s</b> , 1s 111 <sub>B</sub> <b>2s</b> , 2s
CYCWK	8:7	rwh	<b>Cyclic Wake Configuration</b> 00 <sub>B</sub> <b>DISABLED</b> , Timer1 and Timer2 disabled as wake-up sources 01 <sub>B</sub> <b>TIMER1</b> , Timer1 is enabled as wake-up source (Cyclic Wake) 10 <sub>B</sub> <b>TIMER2</b> , Timer2 is enabled as wake-up source (Cyclic Wake) 11 <sub>B</sub> , reserved
TIMER1_ON	6:4	rwh	<b>Timer1 On-Time Configuration</b> 000 <sub>B</sub> <b>OFF</b> , OFF 001 <sub>B</sub> <b>100us</b> , 0.1ms on-time 010 <sub>B</sub> <b>300us</b> , 0.3ms on-time 011 <sub>B</sub> <b>1ms</b> , 1.0ms on-time 100 <sub>B</sub> <b>10ms</b> , 10ms on-time 101 <sub>B</sub> <b>20ms</b> , 20ms on-time 110 <sub>B</sub> , reserved 111 <sub>B</sub> , reserved
RES	3	r	<b>Reserved, always reads as 0</b>

Serial Peripheral Interface

Field	Bits	Type	Description
TIMER1_PER	2:0	rwh	<b>Timer1 Period Configuration</b> 000 <sub>B</sub> <b>10ms</b> , 10ms 001 <sub>B</sub> <b>20ms</b> , 20ms 010 <sub>B</sub> <b>50ms</b> , 50ms 011 <sub>B</sub> <b>100ms</b> , 100ms 100 <sub>B</sub> <b>200ms</b> , 200ms 101 <sub>B</sub> <b>500ms</b> , 500ms 110 <sub>B</sub> <b>1s</b> , 1s 111 <sub>B</sub> <b>2s</b> , 2s

**Table 44** Reset of **TIMER\_CTRL**

Register Reset Type	Reset Values	Reset Short Name	Reset Mode	Note
POR/Soft reset	0000 0000 0000 0000 <sub>B</sub>			
Restart	0000 0000 0000 0000 <sub>B</sub>			

**Notes**

1. The timer must be first assigned and is then automatically activated as soon as the on-time is configured.
2. Timer accuracy is linked to the oscillator accuracy (see Parameter P\_13.12.43).

Serial Peripheral Interface

Interrupt Mask Control<sup>1)</sup>

INT\_MASK

Interrupt Mask Control

(000 1001<sub>B</sub>)

Reset Value: see [Table 45](#)

15	14	13	12	11	10	9	8	7	6	5	4	3	2	1	0
RES						INTN_CYC_EN	WD_SDM_DISABLE	WD_SDM	SPI_CRC_FAIL	BD_STAT	RES	RES	TEMP_STAT	SUPPLY_STAT	
r						rw	rw	rw	rw	rw	rw	rw	rw	rw	rw

Field	Bits	Type	Description
RES	15:9	r	<b>Reserved, always reads as 0</b>
INTN_CYC_EN	8	rw	<b>Periodical INTN generation</b> 0 <sub>B</sub> <b>DISABLED</b> , no periodical INTN event generated in case of pending interrupts 1 <sub>B</sub> <b>ENABLED</b> , periodical INTN event generated in case of pending interrupts
WD_SDM_DISABLE	7	rw	<b>Disable Watchdog in Software Development Mode</b> 0 <sub>B</sub> <b>ENABLED</b> , WD is enabled in Software Development Mode 1 <sub>B</sub> <b>DISABLED</b> , WD is disabled in Software Development Mode
WD_SDM	6	rw	<b>Watchdog failure in Software Development Mode</b> 0 <sub>B</sub> <b>DISABLED</b> , no INTN event generated in case of WD trigger failure in Software Development Mode 1 <sub>B</sub> <b>ENABLED</b> , one INTN event is generated in case of WD trigger failure in Software Development Mode
SPI_CRC_FAIL	5	rw	<b>SPI and CRC interrupt generation</b> 0 <sub>B</sub> <b>DISABLED</b> , no INTN event generated in case of SPI_FAIL or CRC_FAIL 1 <sub>B</sub> <b>ENABLED</b> , one INTN event is generated in case of SPI_FAIL or CRC_FAIL
BD_STAT	4	rw	<b>Bridge Driver Interrupt generation</b> 0 <sub>B</sub> <b>DISABLED</b> , no INTN event generated in case BD_STAT (on Status Information Field) is set 1 <sub>B</sub> <b>ENABLED</b> , one INTN event generated in case BD_STAT (on Status Information Field) is set
RES	3	rw	<b>Reserved, to be set to '0'</b>
RES	2	rw	<b>Reserved, to be set to '0'</b>

1) Every event will generate a signal on the INTN pin (when masked accordingly).  
Even if the status-bit was already set in the corresponding status-register it can still trigger a signal on the INTN pin.

Serial Peripheral Interface

Field	Bits	Type	Description
TEMP_STAT	1	rw	<b>Temperature Interrupt generation</b> 0 <sub>B</sub> <b>DISABLED</b> , no INTN event generated in case TEMP_STAT (on Status Information Field) is set 1 <sub>B</sub> <b>ENABLED</b> , one INTN event generated in case TEMP_STAT (on Status Information Field) is set
SUPPLY_STAT	0	rw	<b>SUPPLY Status Interrupt generation</b> 0 <sub>B</sub> <b>DISABLED</b> , no INTN event generated in case SUPPLY_STAT (on Status Information Field) is set 1 <sub>B</sub> <b>ENABLED</b> , one INTN event generated in case SUPPLY_STAT (on Status Information Field) is set

**Table 45** Reset of **INT\_MASK**

Register Reset Type	Reset Values	Reset Short Name	Reset Mode	Note
POR/Soft reset	0000 0001 0100 0000 <sub>B</sub>			
Restart	0000 000x xxxx xxxx <sub>B</sub>			

Serial Peripheral Interface

System Status Control

**SYS\_STAT\_CTRL**

**System Status Control**

(000 1011<sub>B</sub>)

Reset Value: see [Table 46](#)

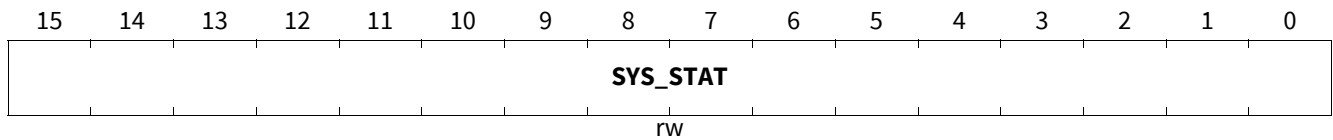

Field	Bits	Type	Description
<b>SYS_STAT</b>	15:0	rw	<b>System Status Control (bit0=LSB; bit15=MSB)</b> Dedicated bytes for system configuration, access only by microcontroller. Cleared after power up and soft reset.

**Table 46** Reset of **SYS\_STAT\_CTRL**

Register Reset Type	Reset Values	Reset Short Name	Reset Mode	Note
POR / Soft reset	0000 0000 0000 0000 <sub>B</sub>			
Restart	XXXX XXXX XXXX XXXX <sub>B</sub>			

*Note:* This register is intended for storing system configuration of the ECU by the microcontroller and is only accessible in Normal Mode. The register is not accessible by the TLE9185QXW and is also not cleared after Fail-Safe or Restart Mode. It allows the microcontroller to quickly store system configuration without losing data.

Serial Peripheral Interface

### 11.5.2 Control registers bridge driver

#### General Bridge Control

##### GENCTRL

##### General Bridge Control

(001 0000<sub>B</sub>)

Reset Value: see [Table 47](#)

15	14	13	12	11	10	9	8	7	6	5	4	3	2	1	0
BDFR EQ	RES	RES	CPUV TH	FET_L VL	CPST GA	BDOV _REC	IPCHG ADT	AGC	CPEN	POCH GDIS	AGCFI LT	EN_GE N_CH ECK	IHOLD	FMOD E	
rw	r	r	rw	rw	rw	rw	rw	rw	rw	rw	rw	rw	rw	rw	

Field	Bits	Type	Description
<b>BDFREQ</b>	15	rw	<b>Bridge driver synchronization frequency</b> 0 <sub>B</sub> <b>18MHz</b> , typ. 18.75 MHz (default) 1 <sub>B</sub> <b>37MHz</b> , typ. 37.5 MHz
<b>RES</b>	14	r	<b>Reserved, always reads as 0</b>
<b>RES</b>	13	r	<b>Reserved, always reads as 0</b>
<b>CPUVTH</b>	12	rw	<b>Charge pump under voltage (referred to VS)</b> 0 <sub>B</sub> <b>TH1</b> , (default) CPUV threshold 1 for FET_LVL = 0, CPUV threshold 1 for FET_LVL = 1 1 <sub>B</sub> <b>TH2</b> , CPUV threshold 2 for FET_LVL = 0, CPUV threshold 2 for FET_LVL = 1
<b>FET_LVL</b>	11	rw	<b>External MOSFET normal / logic level selection</b> 0 <sub>B</sub> <b>LOGIC</b> , Logic level MOSFET selected 1 <sub>B</sub> <b>NORMAL</b> , Normal level MOSFET selected(default)
<b>CPSTGA</b>	10	rw	<b>Automatic switchover between dual and single charge pump stage</b> 0 <sub>B</sub> <b>INACTIVE</b> , Automatic switch over deactivated (default) 1 <sub>B</sub> <b>ACTIVE</b> , Automatic switch over activated
<b>BDOV_REC</b>	9	rw	<b>Bridge driver recover from VS and VSINT Overvoltage</b> 0 <sub>B</sub> <b>INACTIVE</b> , Recover deactivated (default) 1 <sub>B</sub> <b>ACTIVE</b> , Recover activated
<b>IPCHGADT</b>	8	rw	<b>Adaptation of the pre-charge and pre-discharge current</b> 0 <sub>B</sub> <b>1STEP</b> , 1 current step (default) 1 <sub>B</sub> <b>2STEPS</b> , 2 current steps

Serial Peripheral Interface

Field	Bits	Type	Description
<b>AGC</b>	7:6	rw	<b>Adaptive gate control</b> 00 <sub>B</sub> <b>INACTIVE1</b> , (default) Adaptive gate control disabled, pre-charge and pre-discharge disabled 01 <sub>B</sub> <b>INACTIVE2</b> , Adaptive gate control disabled, precharge is enabled with IPRECHG = IPCHGINIT, predischage is enabled with IPREDCHG = IPDCHGINIT 10 <sub>B</sub> <b>ACTIVE</b> , Adaptive gate control enabled, IPRECHG and IPREDCHG are self adapted 11 <sub>B</sub> , reserved. Adaptive gate control enabled, IPRECHG and IPREDCHG are self adapted
<b>CPEN</b>	5	rw	<b>CPEN</b> 0 <sub>B</sub> <b>DISABLED</b> , Charge pump disabled (default) 1 <sub>B</sub> <b>ENABLED</b> , Charge pump enabled
<b>POCHGDIS</b>	4	rw	<b>Postcharge disable bit</b> 0 <sub>B</sub> <b>ENABLED</b> , The postcharge phase is enabled during PWM (default) 1 <sub>B</sub> <b>DISABLED</b> , The postcharge phase is disabled during PWM
<b>AGCFILT</b>	3	rw	<b>Filter for adaptive gate control</b> 0 <sub>B</sub> <b>NO_FILT</b> , No filter applied (default) 1 <sub>B</sub> <b>FILT_APPL</b> , Filter applied
<b>EN_GEN_CHECK</b>	2	rw	<b>Detection of active / FW MOSFET</b> 0 <sub>B</sub> <b>DISABLED</b> , Detection disabled (default) 1 <sub>B</sub> <b>ENABLED</b> , Detection enabled
<b>IHOLD</b>	1	rw	<b>Gate driver hold current IHOLD</b> 0 <sub>B</sub> <b>TH1</b> , (default) Charge: $I_{CHG15}$ , discharge $I_{DCHG15}$ 1 <sub>B</sub> <b>TH2</b> , Charge: $I_{CHG20}$ , discharge: $I_{DCHG20}$
<b>FMODE</b>	0	rw	<b>Frequency modulation of the charge pump</b> 0 <sub>B</sub> <b>NO</b> , No modulation 1 <sub>B</sub> <b>15KHz</b> , Modulation frequency 15.6 kHz (default)

Table 47 Reset of **GENCTRL**

Register Reset Type	Reset Values	Reset Short Name	Reset Mode	Note
POR/Soft reset	0000 1000 0000 0001 <sub>B</sub>			
Restart	x00x xxxx xxxx xxxx <sub>B</sub>			

Serial Peripheral Interface

Current sense amplifier

CSA

Current sense amplifier

(001 0001<sub>B</sub>)

Reset Value: see [Table 48](#)

15	14	13	12	11	10	9	8	7	6	5	4	3	2	1	0
RES					PWM_NB	CSO_CAP	CSD	OCFILT		CSA_OFF	OCTH	CSAG		OCEN	
r					rw	rw	rw	rw		rw	rw	rw		rw	

Field	Bits	Type	Description
RES	15:11	r	Reserved, always reads as 0
PWM_NB	10	rw	<b>Selection of 3 or 6 PWM inputs</b> 0 <sub>B</sub> 3PWM, 3 PWM inputs (default) 1 <sub>B</sub> 6PWM, 6 PWM inputs
CSO_CAP	9	rw	<b>Capacitance connected to the current sense amplifier output (CCSO), see also <a href="#">Chapter 10.10.4</a></b> 0 <sub>B</sub> 400pF, CCSO < 400 pF (default) 1 <sub>B</sub> 2nF, 400 pF < CCSO < 2.2 nF
CSD	8	rw	<b>Direction of the current sense amplifier</b> 0 <sub>B</sub> UNI, Unidirectional 1 <sub>B</sub> BI, Bidirectional (default)
OCFILT	7:6	rw	<b>Overcurrent filter time of CSO</b> 00 <sub>B</sub> 6us, 6 μs (default) 01 <sub>B</sub> 10us, 10 μs 10 <sub>B</sub> 50us, 50 μs 11 <sub>B</sub> 100us, 100 μs
CSA_OFF	5	rw	<b>CSA OFF</b> 0 <sub>B</sub> CSA_ON, CSA enabled 1 <sub>B</sub> CSA_OFF, CSA disabled (default)
OCTH	4:3	rw	<b>Overcurrent detection threshold of CSO</b> 00 <sub>B</sub> TH1, $V_{CSO} > V_{CC1}/2 + 2 \times V_{CC1}/20$ or $V_{CSOx} < V_{CC1}/2 - 2 \times V_{CC1}/20$ (default) 01 <sub>B</sub> TH2, $V_{CSO} > V_{CC1}/2 + 4 \times V_{CC1}/20$ or $V_{CSOx} < V_{CC1}/2 - 4 \times V_{CC1}/20$ 10 <sub>B</sub> TH3, $V_{CSO} > V_{CC1}/2 + 5 \times V_{CC1}/20$ or $V_{CSOx} < V_{CC1}/2 - 5 \times V_{CC1}/20$ 11 <sub>B</sub> TH4, $V_{CSO} > V_{CC1}/2 + 6 \times V_{CC1}/20$ or $V_{CSOx} < V_{CC1}/2 - 6 \times V_{CC1}/20$
CSAG	2:1	rw	<b>Gain of the current sense amplifier</b> 00 <sub>B</sub> 10VV, $G_{DIFF10}$ (default) 01 <sub>B</sub> 20VV, $G_{DIFF20}$ 10 <sub>B</sub> 40VV, $G_{DIFF40}$ 11 <sub>B</sub> 60VV, $G_{DIFF60}$
OCEN	0	rw	<b>Overcurrent shutdown Enable</b> 0 <sub>B</sub> DISABLED, Disabled 1 <sub>B</sub> ENABLED, Enabled (default)



---

Serial Peripheral Interface

**Table 48** Reset of **CSA**

Register Reset Type	Reset Values	Reset Short Name	Reset Mode	Note
POR/Soft reset	0000 0001 0010 0001 <sub>B</sub>			
Restart	0000 0xxx xxxx xxx1 <sub>B</sub>			

Serial Peripheral Interface

Drain-Source monitoring threshold LS1-3

LS\_VDS

VDS monitoring threshold LS1-3

(001 0010<sub>B</sub>)

Reset Value: see [Table 49](#)

15	14	13	12	11	10	9	8	7	6	5	4	3	2	1	0
RES		TFVDS		RES			LS3VDSTH		LS2VDSTH			LS1VDSTH			
r		rw		r			rw		rw			rw			

Field	Bits	Type	Description
RES	15:14	r	<b>Reserved. Always read as 0</b>
TFVDS	13:12	rw	<b>Filter time of drain-source voltage monitoring</b> 00 <sub>B</sub> <b>500ns</b> , 0.5 μs (default) 01 <sub>B</sub> <b>1us</b> , 1 μs 10 <sub>B</sub> <b>2us</b> , 2 μs 11 <sub>B</sub> <b>6us</b> , 6 μs
RES	11:9	r	<b>Reserved, always reads as 0</b>
LS3VDSTH	8:6	rw	<b>LS3 drain-source overvoltage threshold</b> 000 <sub>B</sub> <b>160mV</b> , 0.16 V 001 <sub>B</sub> <b>200mV</b> , 0.20 V (default) 010 <sub>B</sub> <b>300mV</b> , 0.30 V 011 <sub>B</sub> <b>400mV</b> , 0.40 V 100 <sub>B</sub> <b>500mV</b> , 0.50 V 101 <sub>B</sub> <b>600mV</b> , 0.60 V 110 <sub>B</sub> <b>800mV</b> , 0.80 V 111 <sub>B</sub> <b>2V</b> , 2.0 V
LS2VDSTH	5:3	rw	<b>LS2 drain-source overvoltage threshold</b> 000 <sub>B</sub> <b>160mV</b> , 0.16V 001 <sub>B</sub> <b>200mV</b> , 0.20 V (default) 010 <sub>B</sub> <b>300mV</b> , 0.30 V 011 <sub>B</sub> <b>400mV</b> , 0.40 V 100 <sub>B</sub> <b>500mV</b> , 0.50 V 101 <sub>B</sub> <b>600mV</b> , 0.60 V 110 <sub>B</sub> <b>800mV</b> , 0.80 V 111 <sub>B</sub> <b>2V</b> , 2.0 V
LS1VDSTH	2:0	rw	<b>LS1 drain-source overvoltage threshold</b> 000 <sub>B</sub> <b>160mV</b> , 0.16 V 001 <sub>B</sub> <b>200mV</b> , 0.20 V (default) 010 <sub>B</sub> <b>300mV</b> , 0.30 V 011 <sub>B</sub> <b>400mV</b> , 0.40 V 100 <sub>B</sub> <b>500mV</b> , 0.50 V 101 <sub>B</sub> <b>600mV</b> , 0.60 V 110 <sub>B</sub> <b>800mV</b> , 0.80 V 111 <sub>B</sub> <b>2V</b> , 2.0 V

---

Serial Peripheral Interface

**Table 49** Reset of **LS\_VDS**

Register Reset Type	Reset Values	Reset Short Name	Reset Mode	Note
POR/Soft reset	0000 0000 0100 1001 <sub>B</sub>	0000 0000 0000 0000		
Restart	0000 000x xxxx xxxx <sub>B</sub>			

Serial Peripheral Interface

Drain-Source monitoring Threshold HS1-3

HS\_VDS

VDS monitoring threshold HS1-3

(001 0011<sub>B</sub>)

Reset Value: see [Table 50](#)

15	14	13	12	11	10	9	8	7	6	5	4	3	2	1	0
RES		RES	DEEP_ADAP	RES			HS3VDSTH			HS2VDSTH			HS1VDSTH		
r		rw		r			rw			rw			rw		

Field	Bits	Type	Description
RES	15:14	r	<b>Reserved. Always read as 0</b>
RES	13	rw	<b>Reserved. This bit must be programmed to '0'</b>
DEEP_ADAP	12	rw	<b>Deep adaptation enable</b> 0 <sub>B</sub> <b>NO_DEEP_ADAP</b> , Deep adaptation disabled (default) 1 <sub>B</sub> <b>DEEP_ADAP</b> , Deep adaptation enabled
RES	11:9	r	<b>Reserved, always reads as 0</b>
HS3VDSTH	8:6	rw	<b>HS3 drain-source overvoltage threshold</b> 000 <sub>B</sub> <b>160mV</b> , 0.16 V 001 <sub>B</sub> <b>200mV</b> , 0.20 V (default) 010 <sub>B</sub> <b>300mV</b> , 0.30 V 011 <sub>B</sub> <b>400mV</b> , 0.40 V 100 <sub>B</sub> <b>500mV</b> , 0.50 V 101 <sub>B</sub> <b>600mV</b> , 0.60 V 110 <sub>B</sub> <b>800mV</b> , 0.80 V 111 <sub>B</sub> <b>2V</b> , 2.0 V
HS2VDSTH	5:3	rw	<b>HS2 drain-source overvoltage threshold</b> 000 <sub>B</sub> <b>160mV</b> , 0.16 V 001 <sub>B</sub> <b>200mV</b> , 0.20 V (default) 010 <sub>B</sub> <b>300mV</b> , 0.30 V 011 <sub>B</sub> <b>400mV</b> , 0.40 V 100 <sub>B</sub> <b>500mV</b> , 0.50 V 101 <sub>B</sub> <b>600mV</b> , 0.60 V 110 <sub>B</sub> <b>800mV</b> , 0.80 V 111 <sub>B</sub> <b>2V</b> , 2.0 V
HS1VDSTH	2:0	rw	<b>HS1 drain-source overvoltage threshold</b> 000 <sub>B</sub> <b>160mV</b> , 0.16 V 001 <sub>B</sub> <b>200mV</b> , 0.20 V (default) 010 <sub>B</sub> <b>300mV</b> , 0.30 V 011 <sub>B</sub> <b>400mV</b> , 0.40 V 100 <sub>B</sub> <b>500mV</b> , 0.50 V 101 <sub>B</sub> <b>600mV</b> , 0.60 V 110 <sub>B</sub> <b>800mV</b> , 0.80 V 111 <sub>B</sub> <b>2V</b> , 2.0 V

---

Serial Peripheral Interface

**Table 50** Reset of **HS\_VDS**

Register Reset Type	Reset Values	Reset Short Name	Reset Mode	Note
POR/Soft reset	0000 0000 0100 1001 <sub>B</sub>			
Restart	00xx 000x xxxx xxxx <sub>B</sub>			

Serial Peripheral Interface

CCP and times selection

CCP\_BLK

CCP and times selection

(001 0100<sub>B</sub>)

Reset Value: see [Table 51](#)

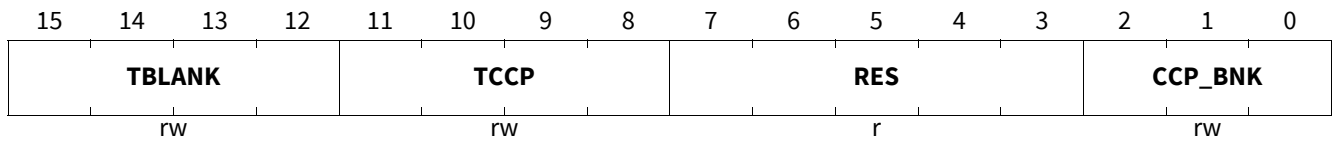

Field	Bits	Type	Description
<b>TBLANK</b>	15:12	rw	<b>Blank time</b> nom. tHBxBLANK = 587 ns + 266 x T[3:0] <sub>D</sub> The CCP_BNK bits select the blank time for the FW or active MOSFET and the half-bridge HBx Reset of active and FW tHBxBLANK: 2450 ns typ.
<b>TCCP</b>	11:8	rw	<b>Cross-current protection time</b> nom. tHBxCCP = 587 ns + 266 x TCCP[3:0] <sub>D</sub> The CCP_BNK bits select the cross-current protection time for the FW or active MOSFET and the half-bridge HBx Reset of all active and FW tHBxCCP: 2450 ns typ.
<b>RES</b>	7:3	r	<b>Reserved, always reads as 0</b>
<b>CCP_BNK</b>	2:0	rw	<b>Cross-current and time banking</b> 000 <sub>B</sub> <b>ACT_HB1</b> , Active blank and cross-current prot. times for HB1 (default) 001 <sub>B</sub> <b>ACT_HB2</b> , Active blank and cross-current prot. times for HB2 010 <sub>B</sub> <b>ACT_HB3</b> , Active blank and cross-current prot. times for HB3 011 <sub>B</sub> <b>RES</b> , reserved 100 <sub>B</sub> <b>FW_HB1</b> , FW blank and cross-current prot. times for HB1 101 <sub>B</sub> <b>FW_HB2</b> , FW blank and cross-current prot. times for HB2 110 <sub>B</sub> <b>FW_HB3</b> , FW blank and cross-current prot. for times for HB3 111 <sub>B</sub> <b>RES</b> , reserved

**Table 51** Reset of **CCP\_BLK**

Register Reset Type	Reset Values	Reset Short Name	Reset Mode	Note
POR/Soft reset	0111 0111 0000 0000 <sub>B</sub>			
Restart	xxxx xxxx 0000 0000 <sub>B</sub>			

Serial Peripheral Interface

Half-Bridge MODE

HBMODE

Half-Bridge MODE

(001 0101<sub>B</sub>)

Reset Value: see [Table 52](#)

15	14	13	12	11	10	9	8	7	6	5	4	3	2	1	0
RES			HB3MODE		AFW3	HB3_PWM_EN	HB2MODE		AFW2	HB2_PWM_EN	HB1MODE		AFW1	HB1_PWM_EN	
r			rw		rw	rw	rw		rw	rw	rw		rw	rw	

Field	Bits	Type	Description
RES	15:12	r	<b>Reserved, always reads as 0</b>
HB3MODE	11:10	rw	<b>Half-bridge 3 MODE selection</b> 00 <sub>B</sub> <b>PASSIVE_OFF</b> , LS3 and HS3 are off by passive discharge (default) 01 <sub>B</sub> <b>LS3_ON</b> , LS3 is ON 10 <sub>B</sub> <b>HS3_ON</b> , HS3 is ON 11 <sub>B</sub> <b>ACTIVE_OFF</b> , LS3 and HS3 kept off by the active discharge
AFW3	9	rw	<b>Active freewheeling for half-bridge 3 during PWM</b> 0 <sub>B</sub> <b>DISABLED</b> , active freewheeling disabled 1 <sub>B</sub> <b>ENABLED</b> , active freewheeling enabled (default)
HB3_PWM_EN	8	rw	<b>PWM mode for half-bridge 3</b> 0 <sub>B</sub> <b>INACTIVE</b> , PWM deactivated for HB2(default) 1 <sub>B</sub> <b>ACTIVE</b> , PWM activated for HB2
HB2MODE	7:6	rw	<b>Half-bridge 2 MODE selection</b> 00 <sub>B</sub> <b>PASSIVE_OFF</b> , LS2 and HS2 are off by passive discharge (default) 01 <sub>B</sub> <b>LS2_ON</b> , LS2 is ON 10 <sub>B</sub> <b>HS2_ON</b> , HS2 is ON 11 <sub>B</sub> <b>ACTIVE_OFF</b> , LS2 and HS2 kept off by the active discharge
AFW2	5	rw	<b>Active freewheeling for half-bridge 2 during PWM</b> 0 <sub>B</sub> <b>DISABLED</b> , active freewheeling disabled 1 <sub>B</sub> <b>ENABLED</b> , active freewheeling enabled (default)
HB2_PWM_EN	4	rw	<b>PWM mode for half-bridge 2</b> 0 <sub>B</sub> <b>INACTIVE</b> , PWM deactivated for HB2(default) 1 <sub>B</sub> <b>ACTIVE</b> , PWM activated for HB2
HB1MODE	3:2	rw	<b>Half-bridge 1 MODE selection</b> 00 <sub>B</sub> <b>PASSIVE_OFF</b> , LS1 and HS1 are off by passive discharge (default) 01 <sub>B</sub> <b>LS1_ON</b> , LS1 is ON 10 <sub>B</sub> <b>HS1_ON</b> , HS1 is ON 11 <sub>B</sub> <b>ACTIVE_OFF</b> , LS1 and HS1 kept off by the active discharge

Serial Peripheral Interface

Field	Bits	Type	Description
AFW1	1	rw	<b>Active freewheeling for half-bridge 1 during PWM</b> 0 <sub>B</sub> <b>DISABLED</b> , active freewheeling disabled 1 <sub>B</sub> <b>ENABLED</b> , active freewheeling enabled (default)
HB1_PWM_EN	0	rw	<b>PWM mode for half-bridge 1</b> 0 <sub>B</sub> <b>INACTIVE</b> , PWM deactivated for HB1 (default) 1 <sub>B</sub> <b>ACTIVE</b> , PWM activated for HB1

**Table 52** Reset of **HBMODE**

Register Reset Type	Reset Values	Reset Short Name	Reset Mode	Note
POR/Soft reset	0000 0010 0010 0010 <sub>B</sub>			
Restart	0000 0010 0010 0010 <sub>B</sub>			



Serial Peripheral Interface

HB pre-charge and pre-discharge time

TPRECHG

HB pre-charge and pre-discharge time

(001 0110<sub>B</sub>)

Reset Value: see [Table 53](#)

15	14	13	12	11	10	9	8	7	6	5	4	3	2	1	0
RES		TPCHG3			TPCHG2			TPCHG1			RES	TPCHG_BNK			
r		rw			rw			rw			r	rw			

Field	Bits	Type	Description
RES	15:13	r	Reserved, always reads as 0
TPCHG3	12:10	rw	If <b>TPCHG_BNK=0</b> : precharge time of HB 3, If <b>TPCHG_BNK=1</b> : pre-discharge time of HB 3
TPCHG2	9:7	rw	If <b>TPCHG_BNK=0</b> : precharge time of HB 2, If <b>TPCHG_BNK=1</b> : pre-discharge time of HB 2
TPCHG1	6:4	rw	If <b>TPCHG_BNK=0</b> : precharge time of HB 1, If <b>TPCHG_BNK=1</b> : pre-discharge time of HB 1
RES	3	r	Reserved, always read as 0
TPCHG_BNK	2:0	rw	<b>Precharge/pre-discharge time selection</b> 000 <sub>B</sub> <b>PRECHARGE</b> , Precharge time selected (default) 001 <sub>B</sub> <b>PREDISCHARGE</b> , Pre-discharge time selected x1x <sub>B</sub> , wrong setting of TPCHG_BNK 1xx <sub>B</sub> , wrong setting of TPCHG_BNK

**Table 53** Reset of **TPRECHG**

Register Reset Type	Reset Values	Reset Short Name	Reset Mode	Note
POR/Soft reset	0000 0000 0000 0000 <sub>B</sub>			
Restart	000x xxxx xxxx 0000 <sub>B</sub>			

Serial Peripheral Interface

Static charge/discharge current

ST\_ICHG

Static charge/discharge current

(001 0111<sub>B</sub>)

Reset Value: see [Table 54](#)

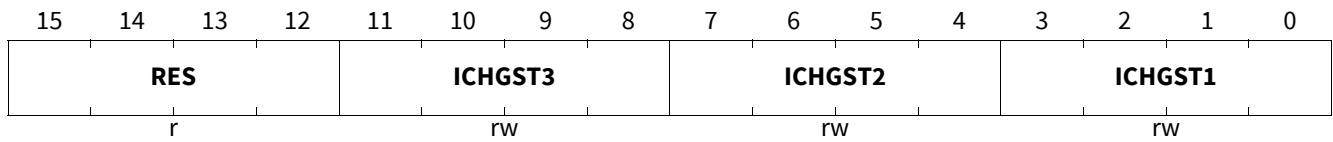

Field	Bits	Type	Description
RES	15:12	r	<b>Reserved, always read as 0</b>
ICHGST3	11:8	rw	<b>Static charge and discharge currents of HB3</b> Refer to <a href="#">Table 17</a> Default: 0100 <sub>B</sub> - charge: $I_{CHG16}$ , 15.3 mA typ., discharge: $I_{DCHG16}$ , 15.1 mA typ.
ICHGST2	7:4	rw	<b>Static charge and discharge currents of HB2</b> Refer to Default: 0100 <sub>B</sub> - charge: $I_{CHG16}$ , 15.3 mA typ., discharge: $I_{DCHG16}$ , 15.1 mA typ.
ICHGST1	3:0	rw	<b>Static charge and discharge currents of HB1</b> Refer to <a href="#">Table 17</a> Default: 0100 <sub>B</sub> - charge: $I_{CHG16}$ , 15.3 mA typ., discharge: $I_{DCHG16}$ , 15.1 mA typ.

**Table 54** Reset of [ST\\_ICHG](#)

Register Reset Type	Reset Values	Reset Short Name	Reset Mode	Note
POR/Soft reset	0000 0100 0100 0100 <sub>B</sub>			
Restart	0000 xxxx xxxx xxxx <sub>B</sub>			

Serial Peripheral Interface

HB charge/discharge currents for PWM operation

HB\_ICHG

HB charge/discharge currents for PWM operation

(001 1000<sub>B</sub>)

Reset Value: see [Table 55](#)

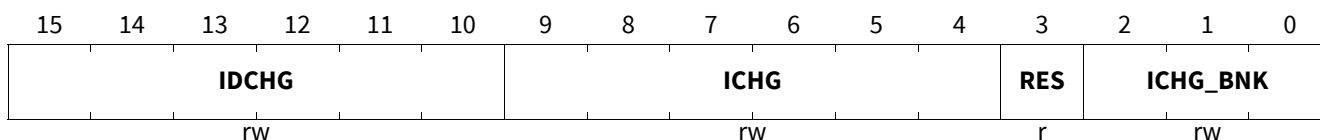

Field	Bits	Type	Description
IDCHG	15:10	rw	<p><b>If ICHG_BNK=0xx<sub>B</sub>: Discharge current of HBx active MOSFET</b></p> <p><b>If ICHG_BNK=1xx<sub>B</sub>: Reserved. Always read as '0'</b></p> <p>Default value for all active MOSFETs discharge currents: 001111<sub>B</sub>, I<sub>DCHG15</sub></p> <p>Refer to <a href="#">Table 25</a> for the configuration of the discharge current</p>
ICHG	9:4	rw	<p><b>If ICHG_BNK=0xx<sub>B</sub>: Charge current of HBx active MOSFET</b></p> <p><b>If ICHG_BNK=1xx<sub>B</sub>: Charge and discharge current of HBx FW MOSFETs</b></p> <p>Default value for all active MOSFETs charge currents and all FW MOSFETs charge/discharge currents: 001101<sub>B</sub>, I<sub>CHG13</sub></p> <p>Refer to <a href="#">Table 24</a> for the configuration of the charge current of the active and FW MOSFET</p> <p>Refer to <a href="#">Table 25</a> for the configuration of the discharge current of the FW MOSFET</p>
RES	3	r	<b>Reserved, always read as 0</b>
ICHG_BNK	2:0	rw	<p><b>Banking bits for charge and discharge currents of active MOSFETs</b></p> <p>000<sub>B</sub> <b>ACT_HB1</b>, Active MOSFET of HB1 is selected (default)</p> <p>001<sub>B</sub> <b>ACT_HB2</b>, Active MOSFET of HB2 is selected</p> <p>010<sub>B</sub> <b>ACT_HB3</b>, Active MOSFET of HB3 is selected</p> <p>011<sub>B</sub> <b>RES</b>, reserved</p> <p>100<sub>B</sub> <b>FW_HB1</b>, FW MOSFET of HB1 is selected</p> <p>101<sub>B</sub> <b>FW_HB2</b>, FW MOSFET of HB2 is selected</p> <p>110<sub>B</sub> <b>FW_HB3</b>, FW MOSFET of HB3 is selected</p> <p>111<sub>B</sub> <b>RES</b>, reserved</p>

**Table 55 Reset of HB\_ICHG**

Register Reset Type	Reset Values	Reset Short Name	Reset Mode	Note
POR/Soft reset	0011 1100 1101 0000 <sub>B</sub>			POR value valid for ICHG_BNK = 0
Restart	xxxx xxxx xxxx 0000 <sub>B</sub>			

Serial Peripheral Interface

HB max. pre-charge/pre-discharge in PWM operation current and diagnostic pull-down

HB\_ICHG\_MAX

HB max. pre-charge/pre-discharge in PWM operation current and diagnostic pull-down

(001 1001<sub>B</sub>)

Reset Value: see [Table 56](#)

15	14	13	12	11	10	9	8	7	6	5	4	3	2	1	0
RES	HB3ID IAG	HB2ID IAG	HB1ID IAG	RES			RES	ICHGMAX3		ICHGMAX2		ICHGMAX1			
r	rrw	rw	rw	r			r	rw		rw		rw			

Field	Bits	Type	Description
RES	15	r	Reserved, always read as 0
HB3IDIAG	14	rrw	Control of HB3 off-state current source and current sink 0 <sub>B</sub> <b>INACTIVE</b> , Pull-down deactivated (default) 1 <sub>B</sub> <b>ACTIVE</b> , Pull-down activated
HB2IDIAG	13	rw	Control of HB2 pull-down for off-state diagnostic 0 <sub>B</sub> <b>INACTIVE</b> , Pull-down deactivated (default) 1 <sub>B</sub> <b>ACTIVE</b> , Pull-down activated
HB1IDIAG	12	rw	Control of HB1 pull-down for off-state diagnostic 0 <sub>B</sub> <b>INACTIVE</b> , Pull-down deactivated (default) 1 <sub>B</sub> <b>ACTIVE</b> , Pull-down activated
RES	11:8	r	Reserved, always read as 0
RES	7:6	r	Reserved, always reads as 0
ICHGMAX3	5:4	rw	Maximum drive current of HB3 during the pre-charge and pre-discharge phases <sup>1)</sup> 00 <sub>B</sub> <b>31mA</b> , charge I <sub>CHG24</sub> : typ. 31.6 mA, discharge I <sub>DCHG24</sub> : typ. 30.9 mA (default) 01 <sub>B</sub> <b>52mA</b> , charge I <sub>CHG32</sub> : typ. 52.5 mA, discharge I <sub>DCHG32</sub> : typ. 51.5 mA 10 <sub>B</sub> <b>112mA</b> , charge I <sub>CHG52</sub> : typ. 112.2mA, discharge I <sub>DCHG52</sub> : typ. 110.8 mA 11 <sub>B</sub> <b>150mA</b> , charge I <sub>CHG63</sub> : typ. 150 mA, discharge I <sub>DCHG63</sub> : typ. 150 mA
ICHGMAX2	3:2	rw	Maximum drive current of HB2 during the pre-charge phase and pre-discharge phases <sup>1)</sup> 00 <sub>B</sub> <b>31mA</b> , charge I <sub>CHG24</sub> : typ. 31.6 mA, discharge I <sub>DCHG24</sub> : typ. 30.9 mA (default) 01 <sub>B</sub> <b>52mA</b> , charge I <sub>CHG32</sub> : typ. 52.5 mA, discharge I <sub>DCHG32</sub> : typ. 51.5 mA 10 <sub>B</sub> <b>112mA</b> , charge I <sub>CHG52</sub> : typ. 112.2mA, discharge I <sub>DCHG52</sub> : typ. 110.8 mA 11 <sub>B</sub> <b>150mA</b> , charge I <sub>CHG63</sub> : typ. 150 mA, discharge I <sub>DCHG63</sub> : typ. 150 mA

Serial Peripheral Interface

Field	Bits	Type	Description
ICHGMAX1	1:0	rw	<p><b>Maximum drive current of HB1 during the pre-charge and pre-discharge phases<sup>1)</sup></b></p> <p>00<sub>B</sub> <b>31mA</b>, charge <math>I_{CHG24}</math>: typ. 31.6 mA, discharge <math>I_{DCHG24}</math>: typ. 30.9 mA (default)</p> <p>01<sub>B</sub> <b>52mA</b>, charge <math>I_{CHG32}</math>: typ. 52.5 mA, discharge <math>I_{DCHG32}</math>: typ. 51.5 mA</p> <p>10<sub>B</sub> <b>112mA</b>, charge <math>I_{CHG52}</math>: typ. 112.2mA, discharge <math>I_{DCHG52}</math>: typ. 110.8 mA</p> <p>11<sub>B</sub> <b>150mA</b>, charge <math>I_{CHG63}</math>: typ. 150 mA, discharge <math>I_{DCHG63}</math>: typ. 150 mA</p>

1) ICHGMAX is also the current applied during the post-charge of the PWM MOSFET.

**Table 56** Reset of **HB\_ICHG\_MAX**

Register Reset Type	Reset Values	Reset Short Name	Reset Mode	Note
POR/Soft reset	0000 0000 0000 0000 <sub>B</sub>			
Restart	0xxx 0000 00xx xxxx <sub>B</sub>			

Serial Peripheral Interface

HBx pre-charge/pre-discharge initialization configuration in PWM operation

HB\_PCHG\_INIT

HBx pre-charge/pre-discharge initialization configuration in PWM operation

(001 1010<sub>B</sub>)

Reset Value: see [Table 57](#)

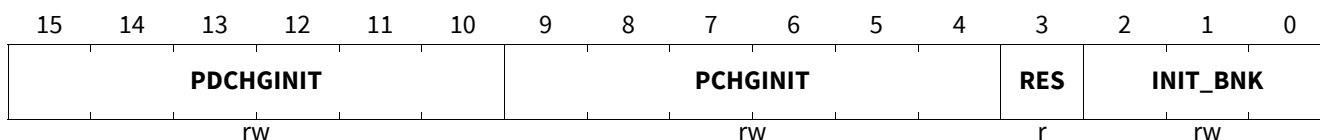

Field	Bits	Type	Description
PDCHGINIT	15:10	rw	<b>Initial predischARGE current of HBx, IPDCHGINITx</b> The INIT_BNK bits select the addressed half-bridge Default: 001111 <sub>B</sub> Refer to <a href="#">Table 24</a>
PCHGINIT	9:4	rw	<b>Initial precharge current of HBx, IPCHGINITx</b> The INIT_BNK bits select the addressed half-bridge Default: 001101 <sub>B</sub> Refer to <a href="#">Table 24</a>
RES	3	r	<b>Reserved, always reads as 0</b>
INIT_BNK	2:0	rw	<b>Banking bits for Precharge an PredischARGE Initial Current</b> 000 <sub>B</sub> <b>HB1</b> , precharge/discharge init. for HB1 selected (default) 001 <sub>B</sub> <b>HB2</b> , precharge/discharge init. for HB2 selected 010 <sub>B</sub> <b>HB3</b> , precharge/discharge init. for HB3 selected 010 <sub>B</sub> <b>RES</b> , reserved 011 <sub>B</sub> <b>RES</b> , reserved 1xx <sub>B</sub> , wrong setting of INIT_BANK

**Table 57** Reset of [HB\\_PCHG\\_INIT](#)

Register Reset Type	Reset Values	Reset Short Name	Reset Mode	Note
POR/Soft reset	0011 1100 1101 0000 <sub>B</sub>			
Restart	xxxx xxxx xxxx 0000 <sub>B</sub>			

Serial Peripheral Interface

HBx inputs TDON configuration

TDON\_HB\_CTRL

HBx inputs TDON configuration

(001 1011<sub>B</sub>)

Reset Value: see [Table 58](#)

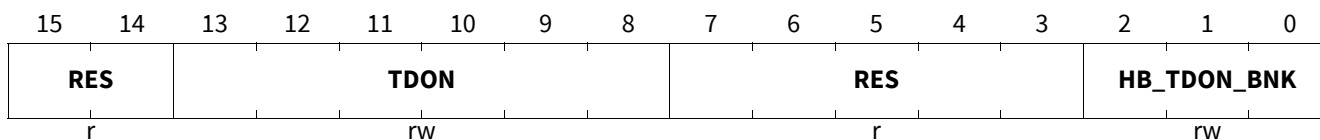

Field	Bits	Type	Description
RES	15:14	r	<b>Reserved, always read as 0</b>
TDON	13:8	rw	<b>Turn-on delay time of active MOSFET of HBx</b> The <b>HB_TDON_BNK</b> bits selects the turn-on delay time of the active MOSFET of the half-bridge HBx Nominal tDON = 53.3 ns x TDON[5:0] <sub>D</sub> Default: 00 1100 <sub>B</sub> : 640 ns typ.
RES	7:3	r	<b>Reserved, always read as 0</b>
HB_TDON_BNK	2:0	rw	<b>Banking bits for turn-on delay time</b> 000 <sub>B</sub> <b>HB1</b> , tDON of HB1 selected (default) 001 <sub>B</sub> <b>HB2</b> , tDON of HB2 selected 010 <sub>B</sub> <b>HB3</b> , tDON of HB3 selected 011 <sub>B</sub> <b>RES</b> , reserved 1xx <sub>B</sub> , wrong setting of PWM_TDON_BNK

**Table 58** Reset of **TDON\_HB\_CTRL**

Register Reset Type	Reset Values	Reset Short Name	Reset Mode	Note
POR/Soft reset	0000 1100 0000 0000 <sub>B</sub>			
Restart	00xx xxxx 0000 0000 <sub>B</sub>			

Serial Peripheral Interface

HBx TDOFF configuration

TDOFF\_HB\_CTRL

HBx TDOFF configuration

(001 1100<sub>B</sub>)

Reset Value: see [Table 59](#)

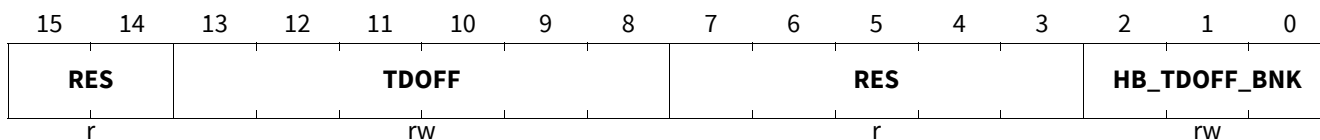

Field	Bits	Type	Description
RES	15:14	r	<b>Reserved, always read as 0</b>
TDOFF	13:8	rw	<b>Turn-off delay time of active MOSFET of HBx</b> The <b>HB_TDOFF_BNK</b> bits selects the turn-off delay time of the active MOSFET of the half-bridge HBx Nominal tDOFF = 53.3 ns x TDOFF[5:0] <sub>D</sub> Default: 0000 1100 <sub>B</sub> : 640 ns
RES	7:3	r	<b>Reserved, always read as 0</b>
HB_TDOFF_BNK	2:0	rw	<b>Banking bits for turn-off delay time</b> 000 <sub>B</sub> <b>HB1</b> , tDOFF of HB1 selected (default) 001 <sub>B</sub> <b>HB2</b> , tDOFF of HB2 selected 010 <sub>B</sub> <b>HB3</b> , tDOFF of HB3 selected 1xx <sub>B</sub> , wrong setting of PWM_TDOFF_BNK

**Table 59** Reset of [TDOFF\\_HB\\_CTRL](#)

Register Reset Type	Reset Values	Reset Short Name	Reset Mode	Note
POR/Soft reset	0000 1100 0000 0000 <sub>B</sub>			
Restart	00xx xxxx 0000 0000 <sub>B</sub>			



Serial Peripheral Interface

Brake control

**BRAKE**

**Brake control**

(001 1101<sub>B</sub>)

Reset Value: see [Table 60](#)

15	14	13	12	11	10	9	8	7	6	5	4	3	2	1	0
RES	RES	SLAM_LS3_DIS	SLAM_LS2_DIS	SLAM_LS1_DIS	SLAM	VDSTH_BRK	TBLK_BRK	PARK_BRK_EN	OV_BRK_EN	RES	RES	RES	RES	RES	OV_BRK_TH
r	r	rw	rw	rw	rw	rw	rw	rw	rw	rw	rw	rw	rw	rw	rw

Field	Bits	Type	Description
RES	15:14	r	Reserved, always read as 0
RES	13	r	Reserved, always read as 0
SLAM_LS3_DIS	12	rw	<b>LS3 output disable during SLAM mode</b> 0 <sub>B</sub> <b>ACTIVE</b> , LS3 control active in Slam mode (default) 1 <sub>B</sub> <b>DISABLED</b> , LS3 control disabled in Slam mode
SLAM_LS2_DIS	11	rw	<b>LS2 output disable during SLAM mode</b> 0 <sub>B</sub> <b>ACTIVE</b> , LS2 control active in Slam mode (default) 1 <sub>B</sub> <b>DISABLED</b> , LS2 control disabled in Slam mode
SLAM_LS1_DIS	10	rw	<b>LS1 output disable during SLAM mode</b> 0 <sub>B</sub> <b>ACTIVE</b> , LS1 control active in Slam mode (default) 1 <sub>B</sub> <b>DISABLED</b> , LS1 control disabled in Slam mode
SLAM	9	rw	<b>Slam mode</b> 0 <sub>B</sub> <b>INACTIVE</b> , Slam mode deactivated (default) 1 <sub>B</sub> <b>ACTIVE</b> , Slam mode activated
VDSTH_BRK	8	rw	<b>VDS Overvoltage for LS1-3 during braking</b> 0 <sub>B</sub> <b>800mV</b> , $V_{VDSMOTH0\_BRAKE}$ : 0.8 V, typ. (default) 1 <sub>B</sub> <b>220mV</b> , $V_{VDSMOTH1\_BRAKE}$ : 0.22 V typ.
TBLK_BRK	7	rw	<b>Blank time of VDS overvoltage during braking</b> 0 <sub>B</sub> <b>7uS</b> , $t_{BLK\_BRAKE1}$ : 7 μs typ. 1 <sub>B</sub> <b>11uS</b> , $t_{BLK\_BRAKE2}$ : 11 μs typ. (default)
PARK_BRK_EN	6	rw	<b>Parking brake enable</b> 0 <sub>B</sub> <b>DISABLED</b> , Parking brake disabled (default) 1 <sub>B</sub> <b>ENABLED</b> , Parking brake enabled
OV_BRK_EN	5	rw	<b>Overvoltage brake enable</b> 0 <sub>B</sub> <b>DISABLED</b> , Overvoltage brake disabled 1 <sub>B</sub> <b>ENABLED</b> , Overvoltage brake enabled (default)
RES	4:3	rw	Reserved, to be set to 0

Serial Peripheral Interface

Field	Bits	Type	Description
OV_BRK_TH	2:0	rw	<b>Overvoltage brake threshold</b> 000 <sub>B</sub> <b>27V</b> , typ. 27V (default) 001 <sub>B</sub> <b>28V</b> , typ. 28V 010 <sub>B</sub> <b>29V</b> , typ. 29V 011 <sub>B</sub> <b>30V</b> , typ. 30V 100 <sub>B</sub> <b>31V</b> , typ. 31V 101 <sub>B</sub> <b>32V</b> , typ. 32V 110 <sub>B</sub> <b>33V</b> , typ. 33V 111 <sub>B</sub> <b>34V</b> , typ. 34V

**Table 60** Reset of **BRAKE**

Register Reset Type	Reset Values	Reset Short Name	Reset Mode	Note
POR/Soft reset	0000 0000 1010 0000 <sub>B</sub>			
Restart	000x xxxx xxx0 0xxx <sub>B</sub>			

Note: For min and max values of **OV\_BRK\_TH**, refer to [Chapter 10.11](#).

**Serial Peripheral Interface**

**11.6 SPI status information registers**

READ/CLEAR Operation (see also [Chapter 11.3](#)):

- One 32-bit SPI command consist of four bytes:
  - The 7-bit address and one additional bit for the register access mode and
  - following the two data bytes and the CRC.
 The numbering of following bit definitions refers to the data byte and correspond to the bits D0...D7 and to the SPI bits 8...23 (see also figure).
- There are two different bit types:
  - ‘r’ = READ: read only bits (or reserved bits).
  - ‘rc’ = READ/CLEAR: readable and clearable bits.
- Reading a register is done word wise by setting the SPI bit 7 to “0” (= Read Only).
- Clearing a register is done word wise by setting the SPI bit 7 to “1”. No single bits can be cleared. Therefore the content of a SPI message (bit 8..23) doesn’t matter.
- SPI status registers are in general not cleared or changed automatically (an exception are the x bits). This must be done by the microcontroller via SPI command.

The registers are addressed wordwise.

**Table 61 Register Overview**

Register Short Name	Register Long Name	Offset Address	Page Number
<b>SPI status information registers, Device Status Registers</b>			
<a href="#">SUP_STAT</a>	Supply Voltage Fail Status	1000000 <sub>B</sub>	<a href="#">164</a>
<a href="#">THERM_STAT</a>	Thermal Protection Status	1000001 <sub>B</sub>	<a href="#">166</a>
<a href="#">DEV_STAT</a>	Device Information Status	1000010 <sub>B</sub>	<a href="#">167</a>
<a href="#">WK_STAT</a>	Wake-up Source and Information Status	1000100 <sub>B</sub>	<a href="#">169</a>
<a href="#">WK_LVL_STAT</a>	WK Input Level	1000101 <sub>B</sub>	<a href="#">170</a>
<b>SPI status information registers, Status registers bridge driver</b>			
<a href="#">GEN_STAT</a>	GEN Status register	1010000 <sub>B</sub>	<a href="#">171</a>
<a href="#">TDREG</a>	Turn-on/off delay regulation register	1010001 <sub>B</sub>	<a href="#">173</a>
<a href="#">DSOV</a>	Drain-source overvoltage HBVOU	1010010 <sub>B</sub>	<a href="#">175</a>
<a href="#">EFF_TDON_OFF1</a>	Effective MOSFET turn-on/off delay - PWM half-bridge 1	1010011 <sub>B</sub>	<a href="#">177</a>
<a href="#">EFF_TDON_OFF2</a>	Effective MOSFET turn-on/off delay - PWM half-bridge 2	1010100 <sub>B</sub>	<a href="#">178</a>
<a href="#">EFF_TDON_OFF3</a>	Effective MOSFET turn-on/off delay - PWM half-bridge 3	1010101 <sub>B</sub>	<a href="#">179</a>
<a href="#">TRISE_FALL1</a>	MOSFET rise/fall time - PWM half-bridge 1	1010111 <sub>B</sub>	<a href="#">180</a>
<a href="#">TRISE_FALL2</a>	MOSFET rise/fall time - PWM half-bridge 2	1011000 <sub>B</sub>	<a href="#">181</a>
<a href="#">TRISE_FALL3</a>	MOSFET rise/fall time - PWM half-bridge 3	1011001 <sub>B</sub>	<a href="#">182</a>
<b>SPI status information registers, Family and product information register</b>			
<a href="#">FAM_PROD_STAT</a>	Family and Product Identification Register	1110000 <sub>B</sub>	<a href="#">183</a>

Serial Peripheral Interface

### 11.6.1 Device Status Registers

#### Supply Voltage Fail Status

**SUP\_STAT**

**Supply Voltage Fail Status**

(100 0000<sub>B</sub>)

Reset Value: see [Table 62](#)

15	14	13	12	11	10	9	8	7	6	5	4	3	2	1	0
POR	RES	CP_OT	VCC1_UV_FS	RES	VSINT_UV	VSINT_OV	VS_UV	VS_OV	CP_UV	VCC1_SC	VCC1_UV	VCC1_OV	VCC1_WARN		
rc	r	rc	rc	rc	rc	rc	rc	rc	rc	rc	rc	rc	rc	rc	rc

Field	Bits	Type	Description
<b>POR</b>	15	rc	<b>Power-On reset detection</b> 0 <sub>B</sub> <b>NO_POR</b> , No POR 1 <sub>B</sub> <b>POR</b> , POR occurred
<b>RES</b>	14:13	r	<b>Reserved, always reads as 0</b>
<b>CP_OT</b>	12	rc	<b>Charge pump overtemperature</b> 0 <sub>B</sub> <b>NO_CP_OT</b> , No charge pump OT detected 1 <sub>B</sub> <b>CP_OT</b> , Charge pump OT detected
<b>VCC1_UV_FS</b>	11	rc	<b>4th consecutive VCC1 UV-Detection</b> 0 <sub>B</sub> <b>NO_FAILSAFE</b> , No Fail-Safe Mode entry due to 4th consecutive VCC1_UV 1 <sub>B</sub> <b>FAILSAFE</b> , Fail-Safe Mode entry due to 4th consecutive VCC1_UV
<b>RES</b>	10:9	rc	<b>Reserved</b>
<b>VSINT_UV</b>	8	rc	<b>VSINT UV-Detection</b> 0 <sub>B</sub> <b>NO_UV</b> , No Undervoltage 1 <sub>B</sub> <b>UV_EVENT</b> , VSINT Undervoltage detected
<b>VSINT_OV</b>	7	rc	<b>VSINT OV-Detection</b> 0 <sub>B</sub> <b>NO_OV</b> , No Overvoltage 1 <sub>B</sub> <b>OV_EVENT</b> , VSINT Overvoltage detected
<b>VS_UV</b>	6	rc	<b>VS Undervoltage Detection (V<sub>s,uv</sub>)</b> 0 <sub>B</sub> <b>NO_VS</b> , No VS undervoltage detected 1 <sub>B</sub> <b>VS_EVENT</b> , VS undervoltage detected (detection is only active when VCC1 is enabled)
<b>VS_OV</b>	5	rc	<b>VS Overvoltage Detection (V<sub>s,ov</sub>)</b> 0 <sub>B</sub> <b>NO_OV</b> , No VS overvoltage detected 1 <sub>B</sub> <b>OV_EVENT</b> , VS overvoltage detected (detection is only active when VCC1 is enabled)
<b>CP_UV</b>	4	rc	<b>CP_UV</b> 0 <sub>B</sub> <b>NO_UV</b> , No CP undervoltage detected 1 <sub>B</sub> <b>UV_EVENT</b> , CP undervoltage detected
<b>VCC1_SC</b>	3	rc	<b>VCC1 SC</b> 0 <sub>B</sub> <b>NO_SC</b> , No VCC1 short to GND detected 1 <sub>B</sub> <b>SC_EVENT</b> , VCC1 short to GND

Serial Peripheral Interface

Field	Bits	Type	Description
VCC1_UV	2	rc	<b>VCC1 UV-Detection (due to Vrtx reset)</b> 0 <sub>B</sub> NO_UV, No VCC1_UV detection 1 <sub>B</sub> UV_EVENT, VCC1 undervoltage detected
VCC1_OV	1	rc	<b>VCC1 Overvoltage Detection</b> 0 <sub>B</sub> NO_OV, No VCC1 overvoltage warning 1 <sub>B</sub> OV_EVENT, VCC1 overvoltage detected
VCC1_WARN	0	rc	<b>VCC1 Undervoltage Prewarning</b> 0 <sub>B</sub> NO_UV, No VCC1 undervoltage prewarning 1 <sub>B</sub> UV_PREWARN, VCC1 undervoltage prewarning detected

**Table 62** Reset of SUP\_STAT

Register Reset Type	Reset Values	Reset Short Name	Reset Mode	Note
POR/Soft reset	y000 0000 0000 0000 <sub>B</sub>			
Restart	x00x xxxx xxxx xxxx <sub>B</sub>			

**Notes**

1. The VCC1 undervoltage prewarning threshold  $V_{PW,f}/V_{PW,r}$  is a fixed threshold and independent of the VCC1 undervoltage reset thresholds.
2. VSINT undervoltage monitoring is not available in Stop Mode due to current consumption saving requirements. Exception: VSINT undervoltage detection is also available in Stop Mode if the VCC1 load current is above the active peak threshold ( $I_{PEAK\_TH}$ ) or if VCC1 is below the VCC1 prewarning threshold (**VCC1\_WARN** is set).
3. The MSB of the POR/Soft Reset value is marked as 'y': the default value of the POR bit is set after Power-on reset (POR value = 1000 0000). However it will be cleared after a device Soft Reset command (Soft Reset value = 0000 0000).
4. During Sleep Mode, the bits VCC1\_SC, VCC1\_OV and VCC1\_UV will not be set when VCC1 is off.
5. The VCC1\_UV bit is never updated in Restart Mode, in Init Mode it is only updated after RSTN was released, it is always updated in Normal Mode and Stop Mode, and it is always updated in any device modes in a VCC1\_SC condition (after VCC1\_UV = 1 for > 2 ms).

Serial Peripheral Interface

Thermal Protection Status

**THERM\_STAT**

Thermal Protection Status

(100 0001<sub>B</sub>)

Reset Value: see [Table 63](#)

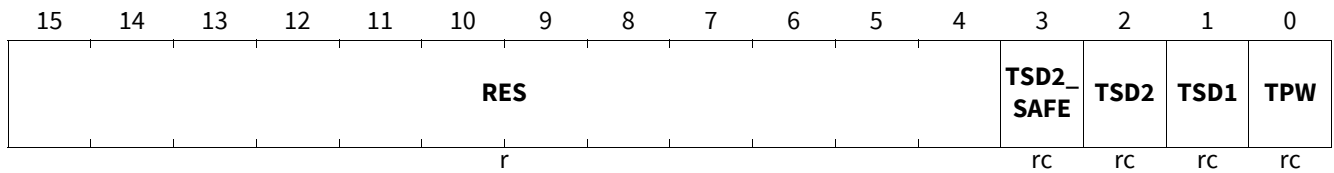

Field	Bits	Type	Description
<b>RES</b>	15:4	r	<b>Reserved, always reads as 0</b>
<b>TSD2_SAFE</b>	3	rc	<b>TSD2 Thermal Shut-Down Safe State Detection</b> 0 <sub>B</sub> <b>NO_TSD2_SF</b> , No TSD2 safe state detected 1 <sub>B</sub> <b>TSD2_SF</b> , TSD2 safe state detected: >16 consecutive TSD2 events occurred, next TSD2 waiting time will be 64s
<b>TSD2</b>	2	rc	<b>TSD2 Thermal Shut-Down Detection</b> 0 <sub>B</sub> <b>NO_TSD2</b> , No TSD2 event 1 <sub>B</sub> <b>TSD2_EVENT</b> , TSD2 OT detected - leading to Fail-Safe Mode
<b>TSD1</b>	1	rc	<b>TSD1 Thermal Shut-Down Detection</b> 0 <sub>B</sub> <b>NO_TSD1</b> , No TSD1 fail 1 <sub>B</sub> <b>TSD1_EVENT</b> , TSD1 OT detected (affected module is disabled)
<b>TPW</b>	0	rc	<b>Thermal Pre Warning</b> 0 <sub>B</sub> <b>NO_TPW</b> , No Thermal Pre warning 1 <sub>B</sub> <b>TPW</b> , Thermal Pre warning detected

**Table 63** Reset of **THERM\_STAT**

Register Reset Type	Reset Values	Reset Short Name	Reset Mode	Note
POR/Soft reset	0000 0000 0000 0000 <sub>B</sub>			
Restart	0000 0000 0000 xxxx <sub>B</sub>			

*Note:* Temperature warning and shutdown bits are not reset automatically, even if the temperature pre warning or the TSD condition is not present anymore.

Serial Peripheral Interface

Device Information Status

DEV\_STAT

Device Information Status

(100 0010<sub>B</sub>)

Reset Value: see [Table 64](#)

15	14	13	12	11	10	9	8	7	6	5	4	3	2	1	0
RES						CRC_S TAT	CRC_F AIL	DEV_STAT	RES	SW_D EV	WD_FAIL	SPI_F AIL	FAILU RE		
r						r	rc	rc	r	rh	rh	rc	rc		

Field	Bits	Type	Description
RES	15:10	r	<b>Reserved, always read as 0</b>
CRC_STAT	9	r	<b>CRC STAT Information</b> 0 <sub>B</sub> <b>DISABLED</b> , CRC disabled 1 <sub>B</sub> <b>ENABLED</b> , CRC enabled
CRC_FAIL	8	rc	<b>CRC Fail Information<sup>1)</sup></b> 0 <sub>B</sub> <b>NO_FAIL</b> , No CRC Failure 1 <sub>B</sub> <b>FAIL</b> , CRC Failure detected
DEV_STAT	7:6	rc	<b>Device Status before Restart Mode</b> 00 <sub>B</sub> <b>CLEARED</b> , Cleared (Register must be actively cleared) 01 <sub>B</sub> <b>RESTART</b> , Restart due to failure (WD fail, TSD2, VCC1_UV, trial to access Sleep Mode without any wake source activated); also after a wake from Fail-Safe Mode 10 <sub>B</sub> <b>SLEEP</b> , Sleep Mode 11 <sub>B</sub> , reserved
RES	5	r	<b>Reserved, always reads 0</b>
SW_DEV	4	rh	<b>Status of Operating Mode</b> 0 <sub>B</sub> <b>NORMAL</b> , Normal operation 1 <sub>B</sub> <b>SW_DEV</b> , Software Development Mode is enabled
WD_FAIL	3:2	rh	<b>Number of WD-Failure Events</b> 00 <sub>B</sub> <b>NO_FAIL</b> , No WD Fail 01 <sub>B</sub> <b>1x</b> , 1x WD Fail, 10 <sub>B</sub> <b>2x</b> , 2x WD Fail 11 <sub>B</sub> <b>3x</b> , more than 3xWD Fail
SPI_FAIL	1	rc	<b>SPI Fail Information</b> 0 <sub>B</sub> <b>NO_FAIL</b> , No SPI fail 1 <sub>B</sub> <b>INVALID</b> , Invalid SPI command detected
FAILURE	0	rc	<b>Failure detection</b> 0 <sub>B</sub> <b>NO_FAIL</b> , No Failure 1 <sub>B</sub> <b>FAIL</b> , Failure occurred

1) The CRC\_FAIL bit will not be set in case the static CRC enabling / disabling sequence is sent (see [Chapter 5.2](#)).

Serial Peripheral Interface

**Table 64** Reset of **DEV\_STAT**

Register Reset Type	Reset Values	Reset Short Name	Reset Mode	Note
POR/Soft reset	0000 0000 0000 0000 <sub>B</sub>			
Restart	0000 00xx xx0x xxxx <sub>B</sub>			

**Notes**

1. The bits **DEV\_STAT** show the status of the device before exiting Restart Mode. Either the device came from regular Sleep Mode or a failure (Restart Mode or Fail-Safe Mode) occurred. Coming from Sleep Mode will also be shown if there was a trial to enter Sleep Mode without having cleared all wake flags before.
2. The **WD\_FAIL** bits are implemented as a counter and are the only status bits, which are cleared automatically by the device.
3. The **SPI\_FAIL** bit can only be cleared via SPI command.
4. The bit **CRC\_STAT** and **CRC\_FAIL** can be read regardless the CRC setting. The SPI read command on **DEV\_STAT** ignores the CRC field.



Serial Peripheral Interface

Wake-up Source and Information Status

WK\_STAT

Wake-up Source and Information Status

(100 0100<sub>B</sub>)

Reset Value: see [Table 65](#)

15	14	13	12	11	10	9	8	7	6	5	4	3	2	1	0
RES					RES	RES	TIMER2_WU	TIMER1_WU	RES		RES	WK4_WU	RES	RES	RES
r					r	r	rc	rc	r		r	rc	r	r	r

Field	Bits	Type	Description
RES	15:11	r	Reserved, always reads as 0
RES	10	r	Reserved, always reads as 0
RES	9	r	Reserved, always reads as 0
TIMER2_WU	8	rc	Wake up via Timer2 0 <sub>B</sub> NO_WU, No Wake up 1 <sub>B</sub> WU, Wake up detected
TIMER1_WU	7	rc	Wake up via Timer1 0 <sub>B</sub> NO_WU, No Wake up 1 <sub>B</sub> WU, Wake up detected
RES	6:5	r	Reserved, always reads as 0
RES	4	r	Reserved, always reads as 0
WK4_WU	3	rc	Wake up via WK4 0 <sub>B</sub> NO_WU, No Wake up 1 <sub>B</sub> WU, Wake up detected
RES	2	r	Reserved, always reads as 0
RES	1	r	Reserved, always reads as 0
RES	0	r	Reserved, always reads as 0

Table 65 Reset of WK\_STAT

Register Reset Type	Reset Values	Reset Short Name	Reset Mode	Note
POR/Soft reset	0000 0000 0000 0000 <sub>B</sub>			
Restart	0000 0xxx x000 00x0 <sub>B</sub>			

Note: At Fail-Safe Mode entry, the **WK\_STAT** register is automatically cleared by the device.

Serial Peripheral Interface

WK Input Level

WK\_LVL\_STAT

WK Input Level

(100 0101<sub>B</sub>)

Reset Value: see [Table 66](#)

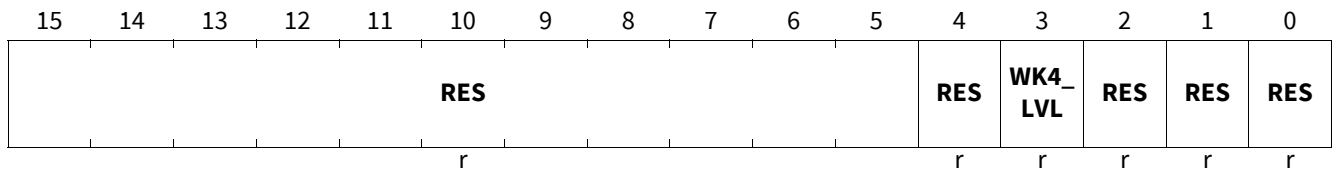

Field	Bits	Type	Description
RES	15:5	r	Reserved, always reads as 0
RES	4	r	Reserved, always reads as 0
WK4_LVL	3	r	<b>Status of WK4</b> 0 <sub>B</sub> <b>LOW</b> , Low Level (=0) 1 <sub>B</sub> <b>HIGH</b> , High Level (=1)
RES	2	r	Reserved, always reads as 0
RES	1	r	Reserved, always reads as 0
RES	0	r	Reserved, always reads as 0

**Table 66** Reset of [WK\\_LVL\\_STAT](#)

Register Reset Type	Reset Values	Reset Short Name	Reset Mode	Note
POR/Soft reset	0000 0000 0000 00x0 <sub>B</sub>			
Restart	0000 0000 0000 00x0 <sub>B</sub>			

*Note:* WK\_LVL\_STAT is updated in Normal Mode and Stop Mode and also in Init and Restart Mode. In cyclic wake mode, the registers contain the sampled level, i.e. the registers are updated after every sampling.

Serial Peripheral Interface

### 11.6.2 Status registers bridge driver

#### General Status register

##### GEN\_STAT

##### General Status register

(101 0000<sub>B</sub>)

Reset Value: see [Table 67](#)

15	14	13	12	11	10	9	8	7	6	5	4	3	2	1	0
RES						RES	HB3V OUT	HB2V OUT	HB1V OUT	PWM6 STAT	PWM5 STAT	PWM4 STAT	PWM3 STAT	PWM2 STAT	PWM1 STAT
r						r	r	r	r	r	r	r	r	r	r

Field	Bits	Type	Description
RES	15:10	r	Reserved, always reads as 0
RES	9	r	Reserved, always reads as 0
HB3VOUT	8	r	Voltage level at VSH3 when HB3MODE[1:0] = 11 and CPEN=1 <sup>1)</sup> 0 <sub>B</sub> LOW, VSH3 = Low : VS - VSH3 > V <sub>HS3VDSTHx</sub> 1 <sub>B</sub> HIGH, VSH3 = High: VS - VSH3 ≤ V <sub>HS3VDSTHx</sub>
HB2VOUT	7	r	Voltage level at VSH2 when HB2MODE[1:0] = 11 and CPEN=1 <sup>1)</sup> 0 <sub>B</sub> LOW, VSH2 = Low : VS - VSH2 > V <sub>HS2VDSTHx</sub> 1 <sub>B</sub> HIGH, VSH2 = High: VS - VSH2 ≤ V <sub>HS2VDSTHx</sub>
HB1VOUT	6	r	Voltage level at VSH1 when HB1MODE[1:0] = 11 and CPEN=1 <sup>1)</sup> 0 <sub>B</sub> LOW, VSH1 = Low : VS - VSH1 > V <sub>HS1VDSTHx</sub> 1 <sub>B</sub> HIGH, VSH1 = High: VS - VSH1 ≤ V <sub>HS1VDSTHx</sub>
PWM6STAT	5	r	<b>PWM6 status</b> 0 <sub>B</sub> LOW, PWM6 is Low 1 <sub>B</sub> HIGH, PWM6 is High
PWM5STAT	4	r	<b>PWM5 status</b> 0 <sub>B</sub> LOW, PWM5 is Low 1 <sub>B</sub> HIGH, PWM5 is High
PWM4STAT	3	r	<b>PWM4 Status</b> 0 <sub>B</sub> LOW, PWM4 is Low 1 <sub>B</sub> HIGH, PWM4 is High
PWM3STAT	2	r	<b>PWM3 status</b> 0 <sub>B</sub> LOW, PWM3 is Low 1 <sub>B</sub> HIGH, PWM3 is High
PWM2STAT	1	r	<b>PWM2 Status</b> 0 <sub>B</sub> LOW, PWM2 is Low 1 <sub>B</sub> HIGH, PWM2 is High
PWM1STAT	0	r	<b>PWM1/CRC status</b> 0 <sub>B</sub> LOW, PWM1/CRC is Low 1 <sub>B</sub> HIGH, PWM1/CRC is High

1) HBxVOUT = 0 if (CPEN=1 and HBxMODE ≠ 11) or CPEN=0.

---

Serial Peripheral Interface

**Table 67** Reset of **GEN\_STAT**

Register Reset Type	Reset Values	Reset Short Name	Reset Mode	Note
POR/Soft reset	0000 0000 0000 0000 <sub>B</sub>			
Restart	0000 0000 xx00 000x <sub>B</sub>			

Serial Peripheral Interface

Turn-on/off delay regulation register

TDREG

Turn-on/off delay regulation register

(101 0001<sub>B</sub>)

Reset Value: see [Table 68](#)

15	14	13	12	11	10	9	8	7	6	5	4	3	2	1	0
RES				RES	IPDCH G3_ST	IPDCH G2_ST	IPDCH G1_ST	RES	IPCHG 3_ST	IPCHG 2_ST	IPCHG 1_ST	RES	TDRE G3	TDRE G2	TDRE G1
r				r	r	r	r	r	r	r	r	r	r	r	r

Field	Bits	Type	Description
RES	15:12	r	<b>Reserved, always reads as 0</b>
RES	11	r	<b>Reserved, always reads as 0</b>
IPDCHG3_ST	10	r	<b>HB3 predischARGE status</b> 0 <sub>B</sub> <b>CLAMP</b> , the predischARGE current is equal to 0.5 mA typ. or ICHGMAX3 if AGC[1:0] = 10 <sub>B</sub> or 11 <sub>B</sub> , and HB3_PWM_EN = 1 <sup>1)</sup> 1 <sub>B</sub> <b>NO_CLAMP</b> , 0.5 mA < predischARGE current < ICHGMAX3 <sup>1)</sup>
IPDCHG2_ST	9	r	<b>HB2 predischARGE status</b> 0 <sub>B</sub> <b>CLAMP</b> , the predischARGE current is equal to 0.5 mA typ. or ICHGMAX2 if AGC[1:0] = 10 <sub>B</sub> or 11 <sub>B</sub> , and HB2_PWM_EN = 1 <sup>1)</sup> 1 <sub>B</sub> <b>NO_CLAMP</b> , 0.5 mA < predischARGE current < ICHGMAX2 <sup>1)</sup>
IPDCHG1_ST	8	r	<b>HB1 predischARGE status</b> 0 <sub>B</sub> <b>CLAMP</b> , the predischARGE current is equal to the 0.5 mA typ. or ICHGMAX1 if AGC[1:0] = 10 <sub>B</sub> or 11 <sub>B</sub> , and HBx_PWM_EN = 1 <sup>1)</sup> 1 <sub>B</sub> <b>NO_CLAMP</b> , 0.5 mA < predischARGE current < ICHGMAX1 <sup>1)</sup>
RES	7	r	<b>Reserved, always reads as 0</b>
IPCHG3_ST	6	r	<b>HB3 prechARGE status</b> 0 <sub>B</sub> <b>CLAMP</b> , the prechARGE current is equal to 0.5 mA typ. or ICHGMAX3 if AGC[1:0] = 10 <sub>B</sub> or 11 <sub>B</sub> , and HB3_PWM_EN = 1 <sup>1)</sup> 1 <sub>B</sub> <b>NO_CLAMP</b> , 0.5 mA < prechARGE current < ICHGMAX3 <sup>1)</sup>
IPCHG2_ST	5	r	<b>HB2 prechARGE status</b> 0 <sub>B</sub> <b>CLAMP</b> , the prechARGE current is equal to 0.5 mA typ. or ICHGMAX2 if AGC[1:0] = 10 <sub>B</sub> or 11 <sub>B</sub> , and HB2_PWM_EN = 1 <sup>1)</sup> 1 <sub>B</sub> <b>NO_CLAMP</b> , 0.5 mA < prechARGE current < ICHGMAX2 <sup>1)</sup>

Serial Peripheral Interface

Field	Bits	Type	Description
IPCHG1_ST	4	r	<b>HB1 precharge status</b> $0_B$ <b>CLAMP</b> , the precharge current is equal to the 0.5 mA typ. or ICHGMAX1 if AGC[1:0] = $10_B$ or $11_B$ , and HB1_PWM_EN = $1^{1)}$ $1_B$ <b>NO_CLAMP</b> , 0.5 mA < precharge current < ICHGMAX1 <sup>1)</sup>
RES	3	r	<b>Reserved, always reads as 0</b>
TDREG3	2	r	<b>HB3 Regulation of turn-on/off delay</b> $0_B$ <b>NO_REG</b> , tDON3 and tDOFF3 are not in regulation $1_B$ <b>REG</b> , tDON3 and/or tDOFF3 are in regulation
TDREG2	1	r	<b>HB2 Regulation of turn-on/off delay</b> $0_B$ <b>NO_REG</b> , tDON2 and tDOFF2 are not in regulation $1_B$ <b>REG</b> , tDON2 and/or tDOFF2 are in regulation
TDREG1	0	r	<b>HB1 Regulation of turn-on/off delay</b> $0_B$ <b>NO_REG</b> , tDON and tDOFF are not in regulation $1_B$ <b>REG</b> , tDON and/or tDOFF are in regulation

1) IPCHGx\_ST = 1 otherwise (PWM disabled, HB in high impedance or AGC[1:0] =  $00_B$  or  $01_B$ ).

**Table 68** Reset of **TDREG**

Register Reset Type	Reset Values	Reset Short Name	Reset Mode	Note
POR/Soft reset	0000 0000 0000 0000 <sub>B</sub>			
Restart	0000 0000 xx00 000x <sub>B</sub>			

Serial Peripheral Interface

Drain-source overvoltage status

DSOV

Drain-source overvoltage

(101 0010<sub>B</sub>)

Reset Value: see [Table 69](#)

15	14	13	12	11	10	9	8	7	6	5	4	3	2	1	0
RES	OC_CSA	VSINTOVBRAKE_ST	VSOVBRAKE_ST	RES	LS3DSOV_BRK	LS2DSOV_BRK	LS1DSOV_BRK	RES	RES	LS3DSOV	HS3DSOV	LS2DSOV	HS2DSOV	LS1DSOV	HS1DSOV
r	rc	rc	rc	r	rc	rc	rc	r	r	rc	rc	rc	rc	rc	rc

Field	Bits	Type	Description
RES	15	r	Reserved, always reads as 0
OC_CSA	14	rc	<b>CSA Overcurrent detection</b> 0 <sub>B</sub> <b>NO_OC</b> , No overcurrent detected 1 <sub>B</sub> <b>OC</b> , Overcurrent detected
VSINTOVBRAKE_ST	13	rc	<b>VSINT Brake status</b> 0 <sub>B</sub> <b>NOT_DETECT</b> , VSINT overvoltage brake condition is not detected 1 <sub>B</sub> <b>DETECT</b> , VSINT overvoltage brake conditions is detected
VSOVBRAKE_ST	12	rc	<b>VS Brake status</b> 0 <sub>B</sub> <b>NOT_DETECT</b> , VS overvoltage brake conditions is not detected 1 <sub>B</sub> <b>DETECT</b> , VS overvoltage brake conditions is detected
RES	11	r	Reserved, always reads as 0
LS3DSOV_BRK	10	rc	<b>Drain-source overvoltage on low-side 3 during braking</b> 0 <sub>B</sub> <b>NO_OV</b> , No drain-source overvoltage on LS3 1 <sub>B</sub> <b>OV</b> , Drain-source overvoltage on LS3
LS2DSOV_BRK	9	rc	<b>Drain-source overvoltage on low-side 2 during braking</b> 0 <sub>B</sub> <b>NO_OV</b> , No drain-source overvoltage on LS2 1 <sub>B</sub> <b>OV</b> , Drain-source overvoltage on LS2
LS1DSOV_BRK	8	rc	<b>Drain-source overvoltage on low-side 1 during braking</b> 0 <sub>B</sub> <b>NO_OV</b> , No drain-source overvoltage on LS1 1 <sub>B</sub> <b>OV</b> , Drain-source overvoltage on LS1
RES	7	r	Reserved, always reads as 0
RES	6	r	Reserved, always reads as 0
LS3DSOV	5	rc	<b>Drain-source overvoltage on low-side 3</b> 0 <sub>B</sub> <b>NO_OV</b> , No drain-source overvoltage on LS3 1 <sub>B</sub> <b>OV</b> , Drain-source overvoltage on LS3

Serial Peripheral Interface

Field	Bits	Type	Description
<b>HS3DSOV</b>	4	rc	<b>Drain-source overvoltage on high-side 3</b> 0 <sub>B</sub> <b>NO_OV</b> , No drain-source overvoltage on HS3 1 <sub>B</sub> <b>OV</b> , Drain-source overvoltage on HS3
<b>LS2DSOV</b>	3	rc	<b>Drain-source overvoltage on low-side 2</b> 0 <sub>B</sub> <b>NO_OV</b> , No drain-source overvoltage on LS2 1 <sub>B</sub> <b>OV</b> , Drain-source overvoltage on LS2
<b>HS2DSOV</b>	2	rc	<b>Drain-source overvoltage on high-side 2</b> 0 <sub>B</sub> <b>NO_OV</b> , No drain-source overvoltage on HS2 1 <sub>B</sub> <b>OV</b> , Drain-source overvoltage on HS2
<b>LS1DSOV</b>	1	rc	<b>Drain-source overvoltage on low-side 1</b> 0 <sub>B</sub> <b>NO_OV</b> , No drain-source overvoltage on LS1 1 <sub>B</sub> <b>OV</b> , Drain-source overvoltage on LS1
<b>HS1DSOV</b>	0	rc	<b>Drain-source overvoltage on high-side 1</b> 0 <sub>B</sub> <b>NO_OV</b> , No drain-source overvoltage on HS1 1 <sub>B</sub> <b>OV</b> , Drain-source overvoltage on HS1

**Table 69** Reset of **DSOV**

Register Reset Type	Reset Values	Reset Short Name	Reset Mode	Note
POR/Soft reset	0000 0000 0000 0000 <sub>B</sub>			
Restart	0xxx 0xxx 00xx xxxx <sub>B</sub>			



Serial Peripheral Interface

Effective MOSFET turn.on/off delay - PWM half-bridge 1

EFF\_TDON\_OFF1

Effective MOSFET turn.on/off delay - HB1 (101 0011<sub>B</sub>)

Reset Value: see [Table 70](#)

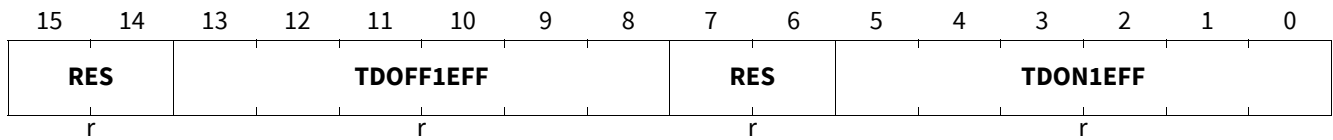

Field	Bits	Type	Description
RES	15:14	r	Reserved, always reads as 0
TDOFF1EFF	13:8	r	<b>Effective active MOSFET turn-off delay HB1</b> Nominal effective tDOFF1 = 53.3 ns x TDOFF1EFF[13:8] <sub>D</sub>
RES	7:6	r	Reserved, always reads as 0
TDON1EFF	5:0	r	<b>Effective active MOSFET turn-on delay HB1</b> Nominal effective tDON1 = 53.3 ns x TDON1EFF[5:0] <sub>D</sub>

**Table 70** Reset of [EFF\\_TDON\\_OFF1](#)

Register Reset Type	Reset Values	Reset Short Name	Reset Mode	Note
POR/Soft reset	0000 0000 0000 0000 <sub>B</sub>			
Restart	00xx xxxx 00xx xxxx <sub>B</sub>			

Serial Peripheral Interface

Effective MOSFET turn.on/off delay - PWM half-bridge 2

EFF\_TDON\_OFF2

Effective MOSFET turn.on/off delay - HB 2 (101 0100<sub>B</sub>)

Reset Value: see [Table 71](#)

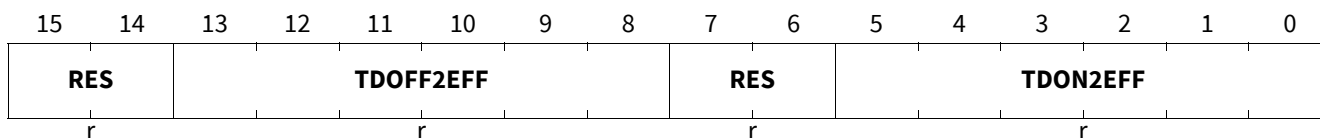

Field	Bits	Type	Description
RES	15:14	r	Reserved, always reads as 0
TDOFF2EFF	13:8	r	<b>Effective active MOSFET turn-off delay HB2</b> Nominal effective tDOFF2 = 53.3 ns x TDOFF2EFF[13:8] <sub>D</sub>
RES	7:6	r	Reserved, always reads as 0
TDON2EFF	5:0	r	<b>Effective active MOSFET turn-on delay HB2</b> Nominal effective tDON2 = 53.3 ns x TDON2EFF[5:0] <sub>D</sub>

**Table 71** Reset of [EFF\\_TDON\\_OFF2](#)

Register Reset Type	Reset Values	Reset Short Name	Reset Mode	Note
POR/Soft reset	0000 0000 0000 0000 <sub>B</sub>			
Restart	00xx xxxx 00xx xxxx <sub>B</sub>			

Serial Peripheral Interface

Effective MOSFET turn.on/off delay - PWM half-bridge 3

EFF\_TDON\_OFF3

Effective MOSFET turn.on/off delay - HB3 (101 0101<sub>B</sub>)

Reset Value: see [Table 72](#)

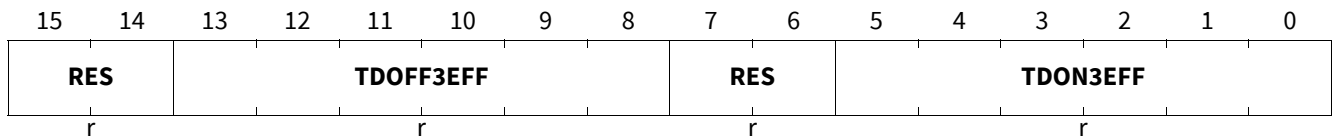

Field	Bits	Type	Description
RES	15:14	r	Reserved, always reads as 0
TDOFF3EFF	13:8	r	Effective active MOSFET turn-off delay HB3 Nominal effective tDOFF3 = 53.3 ns x TDO3EFF[13:8] <sub>D</sub>
RES	7:6	r	Reserved, always reads as 0
TDON3EFF	5:0	r	Effective active MOSFET turn-on delay HB3 Nominal effective tDON3 = 53.3 ns x TDON3EFF[5:0] <sub>D</sub>

**Table 72** Reset of [EFF\\_TDON\\_OFF3](#)

Register Reset Type	Reset Values	Reset Short Name	Reset Mode	Note
POR/Soft reset	0000 0000 0000 0000 <sub>B</sub>			
Restart	00xx xxxx 00xx xxxx <sub>B</sub>			

Serial Peripheral Interface

MOSFET rise/fall time - PWM half-bridge 1

TRISE\_FALL1

MOSFET rise/fall time - HB1

(101 0111<sub>B</sub>)

Reset Value: see [Table 73](#)

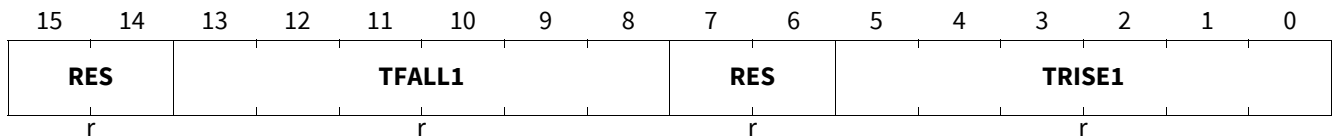

Field	Bits	Type	Description
RES	15:14	r	Reserved, always reads as 0
TFALL1	13:8	r	Active MOSFET fall time HB1 Nominal tFALL1 = 53.3 ns x TFALL1[5:0] <sub>D</sub>
RES	7:6	r	Reserved, always reads as 0
TRISE1	5:0	r	Active MOSFET rise time HB1 Nominal tRISE1 = 53.3 ns x TRISE1[5:0] <sub>D</sub>

Table 73 Reset of [TRISE\\_FALL1](#)

Register Reset Type	Reset Values	Reset Short Name	Reset Mode	Note
POR/Soft reset	0000 0000 0000 0000 <sub>B</sub>			
Restart	00xx xxxx 00xx xxxx <sub>B</sub>			

Serial Peripheral Interface

MOSFET rise/fall time - PWM half-bridge 2

TRISE\_FALL2

MOSFET rise/fall time - HB2

(101 1000<sub>B</sub>)

Reset Value: see [Table 74](#)

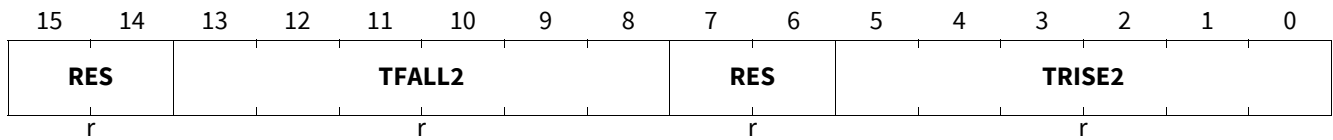

Field	Bits	Type	Description
RES	15:14	r	Reserved, always reads as 0
TFALL2	13:8	r	Active MOSFET fall time HB2 Nominal tFALL2 = 53.3 ns x TFALL2[5:0] <sub>D</sub>
RES	7:6	r	Reserved, always reads as 0
TRISE2	5:0	r	Active MOSFET rise time HB2 Nominal tRISE2 = 53.3 ns x TRISE2[5:0] <sub>D</sub>

Table 74 Reset of [TRISE\\_FALL2](#)

Register Reset Type	Reset Values	Reset Short Name	Reset Mode	Note
POR/Soft reset	0000 0000 0000 0000 <sub>B</sub>			
Restart	00xx xxxx 00xx xxxx <sub>B</sub>			

Serial Peripheral Interface

MOSFET rise/fall time - PWM half-bridge 3

TRISE\_FALL3

MOSFET rise/fall time - HB3

(101 1001<sub>B</sub>)

Reset Value: see [Table 75](#)

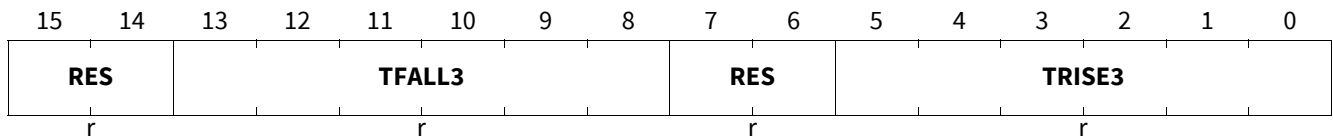

Field	Bits	Type	Description
RES	15:14	r	Reserved, always reads as 0
TFALL3	13:8	r	Active MOSFET fall time HB3 Nominal tFALL3 = 53.3 ns x TFALL3[5:0] <sub>D</sub>
RES	7:6	r	Reserved, always reads as 0
TRISE3	5:0	r	Active MOSFET rise time HB3 Nominal tRISE3 = 53.3 ns x TRISE3[5:0] <sub>D</sub>

Table 75 Reset of [TRISE\\_FALL3](#)

Register Reset Type	Reset Values	Reset Short Name	Reset Mode	Note
POR/Soft reset	0000 0000 0000 0000 <sub>B</sub>			
Restart	00xx xxxx 00xx xxxx <sub>B</sub>			

Serial Peripheral Interface

### 11.6.3 Family and product information register

#### Family and Product Identification Register

##### FAM\_PROD\_STAT

Family and Product Identification Register (111 0000<sub>B</sub>)

Reset Value: see [Table 76](#)

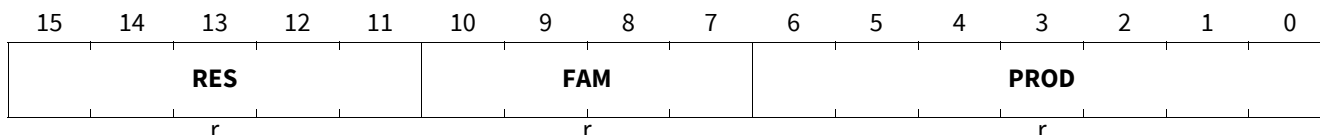

Field	Bits	Type	Description
<b>RES</b>	15:11	r	<b>Reserved, always reads as 0</b>
<b>FAM</b>	10:7	r	<b>Device Family Identifier</b> 1000 <sub>B</sub> , BLDC Driver
<b>PROD</b>	6:0	r	<b>Device Product Identifier</b> 000 0000 <sub>B</sub> <b>TLE9562-3QX/QX</b> , TLE9562-3QX/-3QXJ/QX 000 0001 <sub>B</sub> <b>TLE9561-3QX/QX</b> , TLE9561-3QX/-3QXJ/QX 000 0010 <sub>B</sub> <b>TLE9563-3QX</b> , TLE9563-3QX/-3QXJ/3QXW/3QXWJ 000 0011 <sub>B</sub> <b>TLE9564QX</b> , TLE9564QX/QXW, TLE9185QX/QXW 001 0000 <sub>B</sub> <b>TLE9562-3QX V33</b> , TLE9562-3QX V33 001 0010 <sub>B</sub> <b>TLE9563-3QX V33</b> , TLE9563-3QX V33 001 0011 <sub>B</sub> <b>TLE9564QX V33</b> , TLE9564QX V33, TLE9185QX V33 001 1000 <sub>B</sub> <b>TLE9560QX</b> , TLE9560-3QX/-3QXJ

**Table 76** Reset of **FAM\_PROD\_STAT**

Register Reset Type	Reset Values	Reset Short Name	Reset Mode	Note
POR/Soft reset	0000 0100 0000 0011 <sub>B</sub>			
Restart	0000 0100 0000 0011 <sub>B</sub>			

## 11.7 Electrical Characteristics

**Table 77 Electrical Characteristics: Power Stage**

$V_{SINT} = 5.5\text{ V to }28\text{ V}$ ,  $T_j = -40^\circ\text{C to }+175^\circ\text{C}$ , all voltages with respect to ground, positive current flowing into pin (unless otherwise specified)

Parameter	Symbol	Values			Unit	Note or Test Condition	Number
		Min.	Typ.	Max.			
<b>SPI frequency</b>							
Maximum SPI frequency	$f_{SPI,max}$	–	–	6.0	MHz	<sup>1)</sup> $V_{CC1} > 3\text{ V}$	P_14.7.1
<b>SPI Interface; Logic Inputs SDI, CLK and CSN</b>							
H-input Voltage Threshold	$V_{IH}$	–	–	$0.7 \times V_{CC1}$	V	–	P_14.7.2
L-input Voltage Threshold	$V_{IL}$	$0.3 \times V_{CC1}$	–	–	V	–	P_14.7.3
Hysteresis of input Voltage	$V_{IHY}$	–	$0.12 \times V_{CC1}$	–	V	<sup>1)</sup>	P_14.7.4
Pull-up Resistance at pin CSN	$R_{ICSN}$	20	40	80	k $\Omega$	–	P_14.7.5
Pull-down Resistance at pin SDI and CLK	$R_{ICLK/SDI}$	20	40	80	k $\Omega$	$V_{SDI/CLK} = 0.2 \times V_{CC1}$	P_14.7.6
Input Capacitance at pin CSN, SDI or CLK	$C_I$	–	10	–	pF	<sup>1)</sup> $V_{CSN}, V_{SDI}, V_{CLK} = V_{CC1}$	P_14.7.7
<b>Logic Output SDO</b>							
H-output Voltage Level	$V_{SDOH}$	$0.8 \times V_{CC1}$	–	–	V	$I_{DOH} = -2\text{ mA}$	P_14.7.8
L-output Voltage Level	$V_{SDOL}$	–	–	$0.2 \times V_{CC1}$	V	$I_{DOL} = 2\text{ mA}$	P_14.7.9
‘Tri-state Input Capacitance	$C_{SDO}$	–	10	15	pF	<sup>1)</sup> $V_{CSN}, V_{SDI}, V_{CLK} = V_{CC1}$	P_14.7.11
Tri-state Leakage Current	$I_{SDOLK}$	–10	–	10	$\mu\text{A}$	<sup>1)</sup> $V_{CSN} = V_{CC1}$ , $0\text{V} < V_{SDO} < V_{CC1}$	P_14.7.38
<b>Data Input Timing<sup>1)</sup></b>							
Clock Period	$t_{pCLK}$	160	–	–	ns	–	P_14.7.12
Clock HIGH Time	$t_{CLKH}$	70	–	–	ns	–	P_14.7.13
Clock LOW Time	$t_{CLKL}$	70	–	–	ns	–	P_14.7.14
Clock LOW before CSN LOW	$t_{bef}$	70	–	–	ns	–	P_14.7.15
CSN Setup Time	$t_{lead}$	160	–	–	ns	–	P_14.7.16
CLK Setup Time	$t_{lag}$	160	–	–	ns	–	P_14.7.17
Clock LOW after CSN HIGH	$t_{beh}$	70	–	–	ns	–	P_14.7.18
SDI Setup Time	$t_{DISU}$	60	–	–	ns	–	P_14.7.19
SDI Hold Time	$t_{DIHO}$	40	–	–	ns	–	P_14.7.20



**Serial Peripheral Interface**

**Table 77 Electrical Characteristics: Power Stage (cont'd)**

$V_{SINT} = 5.5\text{ V to }28\text{ V}$ ,  $T_j = -40^\circ\text{C to }+175^\circ\text{C}$ , all voltages with respect to ground, positive current flowing into pin (unless otherwise specified)

Parameter	Symbol	Values			Unit	Note or Test Condition	Number
		Min.	Typ.	Max.			
Input Signal Rise Time at pin SDI, CLK and CSN	$t_{rIN}$	–	–	20	ns	–	P_14.7.21
Input Signal Fall Time at pin SDI, CLK and CSN	$t_{fIN}$	–	–	20	ns	–	P_14.7.22
Delay Time for Mode Changes <sup>2)</sup>	$t_{Del,Mode}$	–	–	5	$\mu\text{s}$	<sup>3)</sup>	P_14.7.23
CSN HIGH Time	$t_{CSN(high)}$	3	–	–	$\mu\text{s}$	–	P_14.7.24

**Data Output Timing<sup>1)</sup>**

SDO Rise Time	$t_{rSDO}$	–	30	40	ns	$C_L = 50\text{ pF}$ , $0.2 \times V_{CC1}$ to $0.8 \times V_{CC1}$	P_14.7.25
SDO Fall Time	$t_{fSDO}$	–	30	40	ns	$C_L = 50\text{ pF}$ , $0.8 \times V_{CC1}$ to $0.2 \times V_{CC1}$	P_14.7.26
SDO Enable Time	$t_{ENSDO}$	–	–	40	ns	LOW impedance	P_14.7.27
SDO Disable Time	$t_{DISSDO}$	–	–	40	ns	HIGH impedance	P_14.7.28
SDO Valid Time	$t_{VASDO}$	–	–	40	ns	$C_L = 50\text{ pF}$	P_14.7.29

- 1) Not subject to production test; specified by design.
- 2) Applies to all mode changes triggered via SPI commands.
- 3) Guaranteed by design.

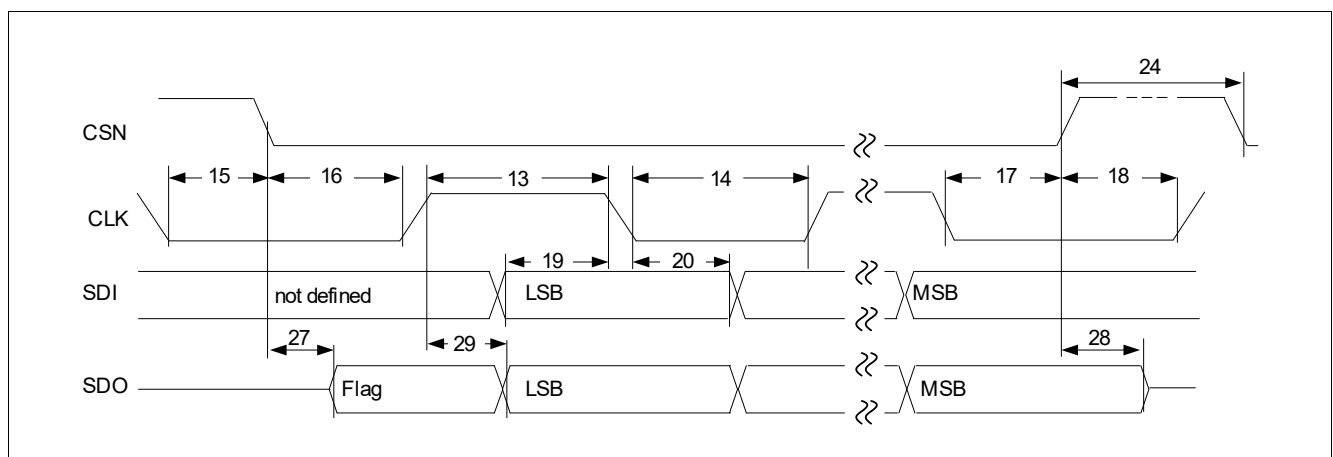

**Figure 61 SPI Timing Diagram**

*Note: Numbers in drawing correlate with the last 2 digits of the Number field in the Electrical Characteristics table.*

Application Information

## 12 Application Information

Note: The following information is given as a hint for the implementation of the device only and shall not be regarded as a description or warranty of a certain functionality, condition or quality of the device.

### 12.1 Application Diagrams

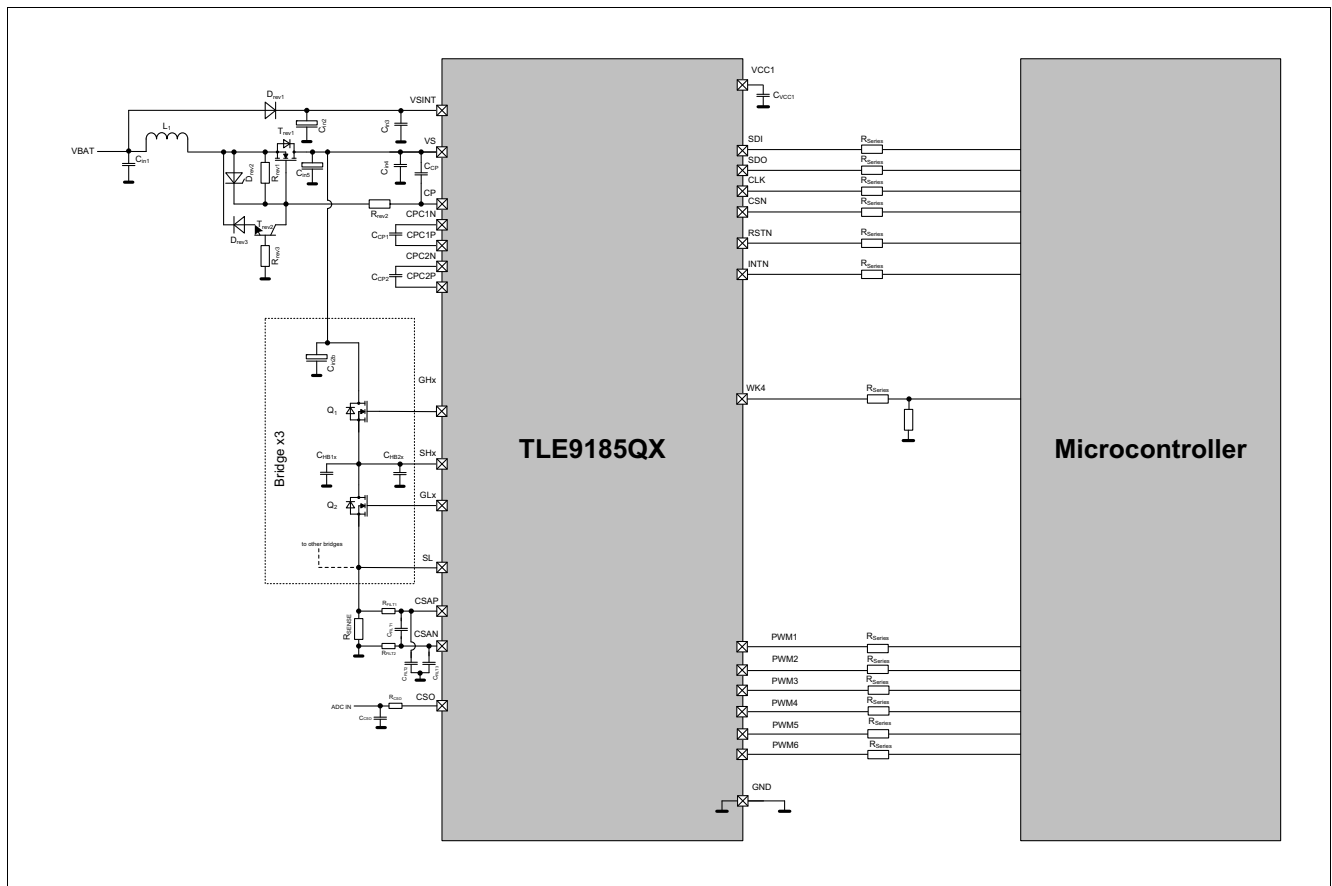

Figure 62 Application Diagram

Note: This is a very simplified example of an application circuit. The function must be always verified in the real application.

Note: Before going to sleep mode, it is highly recommended keep the WK4 internal pull-up and pull-down deactivated, keep WK4 to Low and enable the static wake for WK4. The 5V microcontroller wakes up the device by pulling WK4 above  $V_{WKx\_th,r}$

**Application Information**

**Table 78 Bill of Material**

Ref.	Typical Value	Purpose / Comment
<b>Capacitances</b>		
$C_{in1}$	100 nF $\pm 20\%$ ceramic	Input filter battery capacitor for optimum EMC behavior
$C_{in2}$	100 $\mu$ F $\pm 20\%$ , 50 V Electrolytic	Buffering capacitor to cut off battery spikes, depending on the application
$C_{in2b}$	470 $\mu$ F $\pm 20\%$ , 50 V Electrolytic	Buffering capacitor for bridges. Cut off battery spikes, depending on the application
$C_{in3}$	100 nF $\pm 20\%$ , 50 V Ceramic	Input capacitor
$C_{in4}$	100 nF $\pm 20\%$ , 50 V Ceramic	Input capacitor
$C_{in5}$	470 $\mu$ F $\pm 20\%$ , 50 V Electrolytic	Buffering capacitor for bridges. Cut off battery spikes, depending on the application
$C_{CP}$	470 nF $\pm 20\%$ , 50 V Ceramic	Charge-Pump buffering capacitor
$C_{CP1} / C_{CP2}$	220 nF $\pm 20\%$ , 50 V Ceramic	Charge-Pump flying capacitor to be placed as closed as possible to the device pins, in order to minimize the length of the PCB tracks
$C_{FILT1}$	1.5 nF $\pm 20\%$ , 16 V Ceramic	Current-sense filtering
$C_{FILT2} / C_{FILT3}$	22 nF $\pm 20\%$ , 16 V Ceramic	Current-sense filtering
$C_{CSO}$	16 V Ceramic	CSO buffering cap for a stable ADC voltage. Max 400 pF in case no resistor is used. With 50 $\Omega$ resistor up to 2.2 nF. (See CSA configuration register)
$C_{VCC1}$	2.2 $\mu$ F $\pm 20\%$ , 16 V	Blocking capacitor. Low ESR. Minimum 1 $\mu$ F effective capacitance
$C_{HB1x}$	10 nF $\pm 20\%$ , 50 V Ceramic	Half-Bridge EME (electromagnetic emission) and ESD suppression filter to be placed close to the connector. Other capacitance values might be needed depending on application
$C_{HB2x}$	560 pF $\pm 20\%$ , 50 V Ceramic	Optional filter for EMI immunity to be placed close to the SHx pin (PCB footprints highly recommended). Other capacitance values might be needed depending on application
$C_{WK1} / C_{WK2}$	47 nF / OEM dependent	Spike filtering, as required by application, mandatory protection for off-board connections
<b>Inductances</b>		
$L_1$	4 $\mu$ H ... 6 $\mu$ H	Input filter for power stage - consider high current rating (application dependent)

**Application Information**

**Table 78 Bill of Material** (cont'd)

Ref.	Typical Value	Purpose / Comment
<b>Resistances</b>		
R <sub>REV1</sub>	100 kΩ ±5%	Other values needed depending on application
R <sub>REV2</sub>	10 kΩ ±5%	Device protection against reverse battery
R <sub>REV3</sub>	10 kΩ ±5%	
R <sub>SENSE</sub>	5 mΩ ±1%	Current-sense resistor
R <sub>FILT1</sub> / R <sub>FILT2</sub>	4.7 Ω ±5%	Current-sense filtering
R <sub>CSO</sub>	50 Ω ±5%	Compensation for internal opamp. Depending on SPI configuration
R <sub>LED</sub>	1 k	Limit LED-current
R <sub>WK1</sub> / R <sub>WK2</sub> / R <sub>WK3</sub> / R <sub>WK4</sub>	10 kΩ ±5%	
R <sub>SERIES</sub>		The value of the resistor depends on the voltage difference between VCC1 and the microcontroller GPIO voltage
<b>Active Components</b>		
D <sub>REV1</sub>	RR268MM600	Reverse polarity protection
D <sub>REV2</sub>	BZX84C16	Gate protection. Limit V <sub>GS</sub>
D <sub>REV3</sub>	BAS21	
T <sub>REV1</sub>	IPZ40N04S5L-2R8	Reverse battery protection, N-MOS
T <sub>REV2</sub>	BC846	
Q <sub>1</sub> / Q <sub>2</sub>	IPZ40N04S5-3R1	Main power switches

Application Information

12.2 ESD Tests

12.2.1 ESD according to IEC61000-4-2

Tests for ESD robustness according to IEC61000-4-2 “GUN test” (150 pF, 330 Ω) have been performed. The results and test condition are available in a test report. The values for the test are listed below.

**Table 79 ESD “GUN test”<sup>1)</sup>**

Performed Test	Result	Unit	Remarks
ESD at pin VS,VSINT,VS, WKx versus GND	> 6	kV	positive pulse
ESD at pin VS,VSINT,VS, WKx versus GND	< -6	kV	negative pulse

1) ESD Test “Gun Test” is specified with external components for pins VS, VSINT, VS, WKx. See the application diagram in [Chapter 12.1](#) for more information.

## 12.3 Thermal Behavior of Package

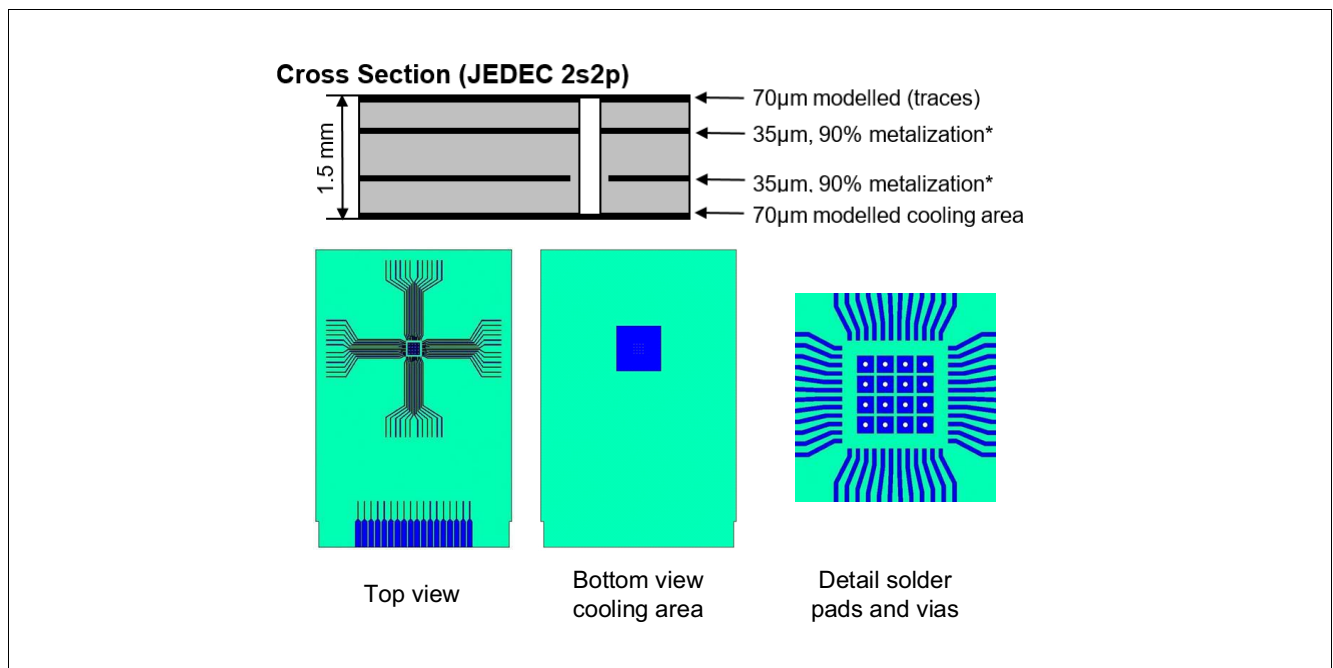

**Figure 63 Board Setup**

Board setup is defined according JESD 51-2, -5, -7.

Board:  $76.2 \times 114.3 \times 1.5 \text{ mm}^3$  with 2 inner copper layers (35  $\mu\text{m}$  thick), with thermal via array under the exposed pad contacting the first inner copper layer and 300  $\text{mm}^2$  cooling area on the bottom layer (70  $\mu\text{m}$ ).

## 12.4 Further Application Information

- The VS pin supplies the bridge driver and the charge pump, and is the sense pin for the high-side MOSFETs drain voltage. It is therefore highly recommended to connect a 100 nF / 50V ceramic by-pass capacitor as close as possible to the VS pin with a short PCB trace to GND.
- Please contact us for information regarding the FMEA pin
- For further information you may contact <http://www.infineon.com/>

### 13 Package Outlines

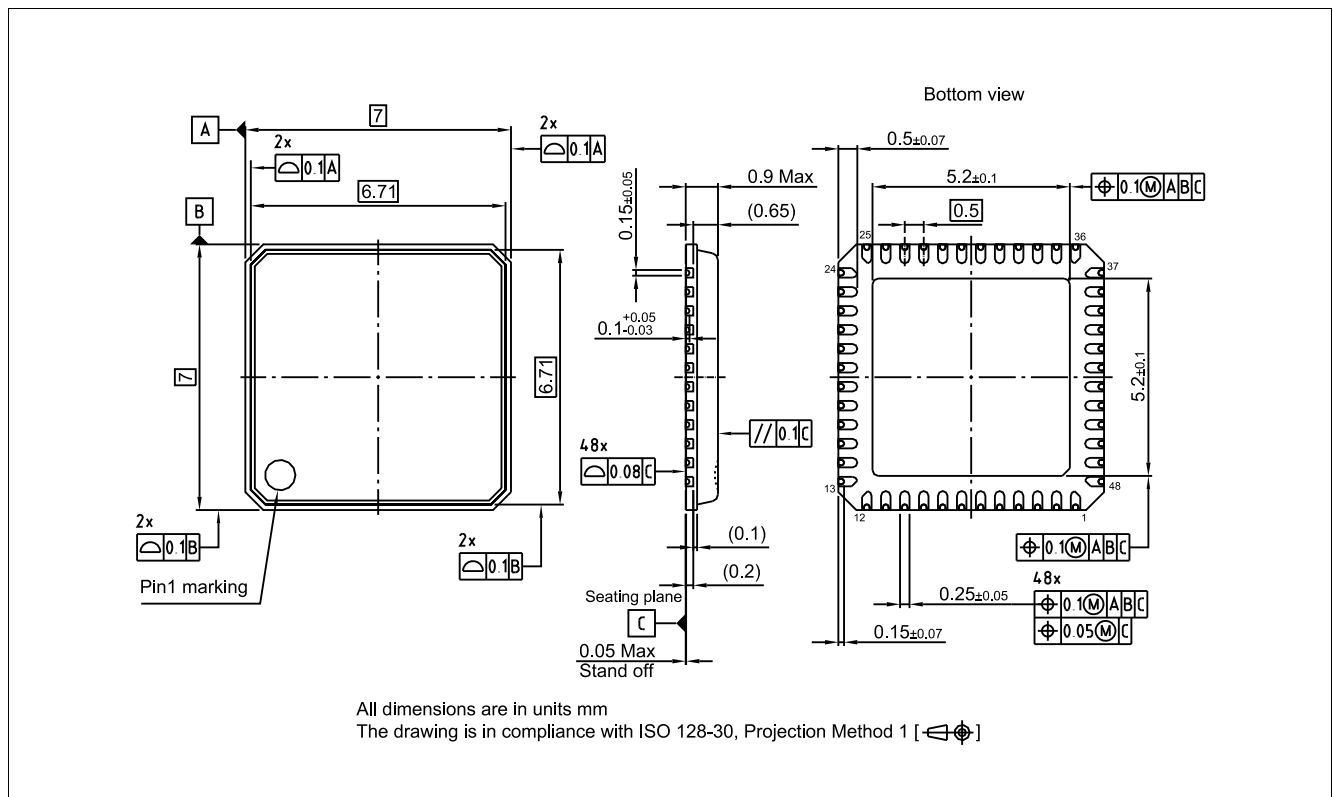

Figure 64 PG-VQFN-48-79

#### Green Product (RoHS compliant)

To meet the world-wide customer requirements for environmentally friendly products and to be compliant with government regulations the device is available as a green product. Green products are RoHS-Compliant (i.e Pb-free finish on leads and suitable for Pb-free soldering according to IPC/JEDEC J-STD-020).

#### Further information on packages

<https://www.infineon.com/packages>

---

**Revision History**

## **14 Revision History**

<b>Revision</b>	<b>Date</b>	<b>Changes</b>
1.0	2024-07-01	First release



## Trademarks

All referenced product or service names and trademarks are the property of their respective owners.

**Edition 2024-07-01**

**Published by**

**Infineon Technologies AG**

**81726 Munich, Germany**

**© 2024 Infineon Technologies AG.**

**All Rights Reserved.**

**Do you have a question about any aspect of this document?**

**Email: [erratum@infineon.com](mailto:erratum@infineon.com)**

## IMPORTANT NOTICE

The information given in this document shall in no event be regarded as a guarantee of conditions or characteristics ("Beschaffheitsgarantie").

With respect to any examples, hints or any typical values stated herein and/or any information regarding the application of the product, Infineon Technologies hereby disclaims any and all warranties and liabilities of any kind, including without limitation warranties of non-infringement of intellectual property rights of any third party.

In addition, any information given in this document is subject to customer's compliance with its obligations stated in this document and any applicable legal requirements, norms and standards concerning customer's products and any use of the product of Infineon Technologies in customer's applications.

The data contained in this document is exclusively intended for technically trained staff. It is the responsibility of customer's technical departments to evaluate the suitability of the product for the intended application and the completeness of the product information given in this document with respect to such application.

For further information on technology, delivery terms and conditions and prices, please contact the nearest Infineon Technologies Office ([www.infineon.com](http://www.infineon.com)).

## WARNINGS

Due to technical requirements products may contain dangerous substances. For information on the types in question please contact your nearest Infineon Technologies office.

Except as otherwise explicitly approved by Infineon Technologies in a written document signed by authorized representatives of Infineon Technologies, Infineon Technologies' products may not be used in any applications where a failure of the product or any consequences of the use thereof can reasonably be expected to result in personal injury.

# Mouser Electronics

Authorized Distributor

Click to View Pricing, Inventory, Delivery & Lifecycle Information:

[Infineon:](#)

[TLE9185QXWXUMA1](#)