

TLE49SRI3**XENSIV™ magnetic position sensors****Features**

- Intrinsic stray field robustness
- Differential Hall based angle sensor
- 360° angle measurement
- Angle speed information
- PSI5 protocol V1.3 and V2.3 chassis and safety
- Leaded package with integrated capacitors
- Max. +/-1° intrinsic angle error over lifetime and temperature range
- High voltage and reverse polarity capability
- 14 bit over 360° representation of absolute angle value on the output
- EEPROM for storage of configuration (e.g. zero angle) and customer specific ID
- ISO 26262 Safety Element out of Context for safety requirements up to ASIL C(D)
- Look-up table to correct for systematic angle errors (e.g. magnetic circuit)
- Single-wire SIC1 programming interface on output pin
- RoHS compliant and halogen free package

**Potential Applications**

- Chassis height sensor
- Pedal position sensor
- Throttle position sensor
- Steering angle sensor
- Wiper position sensor

Product Validation

Product validation according to AEC-Q100, Grade 0. Qualified for automotive applications.

Description

The TLE49SR is a stray field robust angle sensor based on Hall technology for measuring absolute angular position in the range from 0° to 360°. The sensor provides the digital output interface PSI5 according V2.3 base standard and V2.3 substandard chassis and safety. It also supports basic operational modes of the PSI5 V1.3 specification. Spatially separated Hall cells, which enable a stray field robust measurement of the magnetic field, and signal conditioning circuits are implemented on the integrated circuit (IC). The sensor is developed according to ISO 26262 as safety element out of context.

Table 1 Variant Ordering codes

Product Type	Marking	Ordering Code	Package	Comment
TLE49SRI3	49SRI3	SP005398935	PG-SSO-3-41	PSI5 Interface

Table of contents

	Table of contents	2
1	Block diagram	4
2	Pin configuration	5
3	General product characteristics	6
3.1	Absolute Maximum Ratings	6
3.2	ESD Immunity	6
3.3	Stray Field Robustness	7
3.4	Lifetime and Ignition Cycles	7
3.5	Functional range	7
3.6	Thermal Resistance	9
4	Product features	10
4.1	Functional description	10
4.1.1	Angle Accuracy	10
4.1.2	Interface timing	10
4.2	Electrical characteristics	13
4.3	Internal circuitry for PG-SSO-3-41	13
5	Specific module descriptions	14
5.1	Diagnostic functions	14
5.1.1	Magnetic field out of range	14
5.1.2	Under- and overvoltage conditon	14
5.2	Interfaces	15
5.2.1	PSI5 Interface	15
5.2.1.1	PSI5 current modulation	16
5.2.1.2	Synchronization pulse	17
5.2.1.3	PSI5 Initialization modes	18
5.2.1.4	Slot ID definition	19
5.2.1.5	Frame control	19
5.2.1.6	Transmission Modes	19
5.2.1.6.1	Asynchronous mode	19
5.2.1.6.2	P10P mode	19
5.2.1.6.3	P10 high resolution	23
5.2.1.6.4	P16CRC mode	31
5.2.1.6.5	P20CRC mode	36
5.2.2	SICI programming interface	39
5.3	Programming characteristics	40
5.3.1	Calibration and Look-Up-Table (LUT)	40
5.3.2	Programmable measurement range	42
5.3.3	EEPROM	43

6	Application Information	44
7	Package information	45
8	Revision history	49
	Disclaimer	50

TLE49SRI3

Stray field robust angle sensor with PSI5 interface

1 Block diagram

1 Block diagram

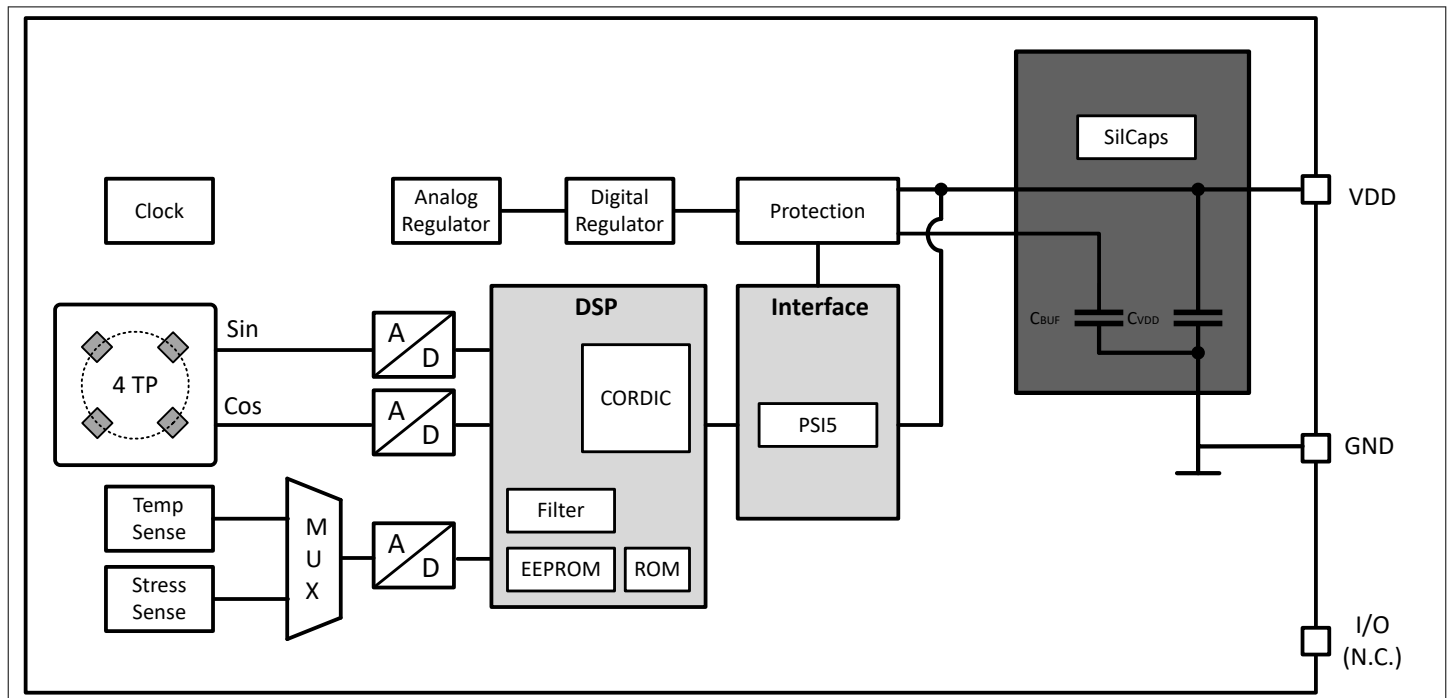

Figure 1 Functional block diagram of TLE49SR

2 Pin configuration

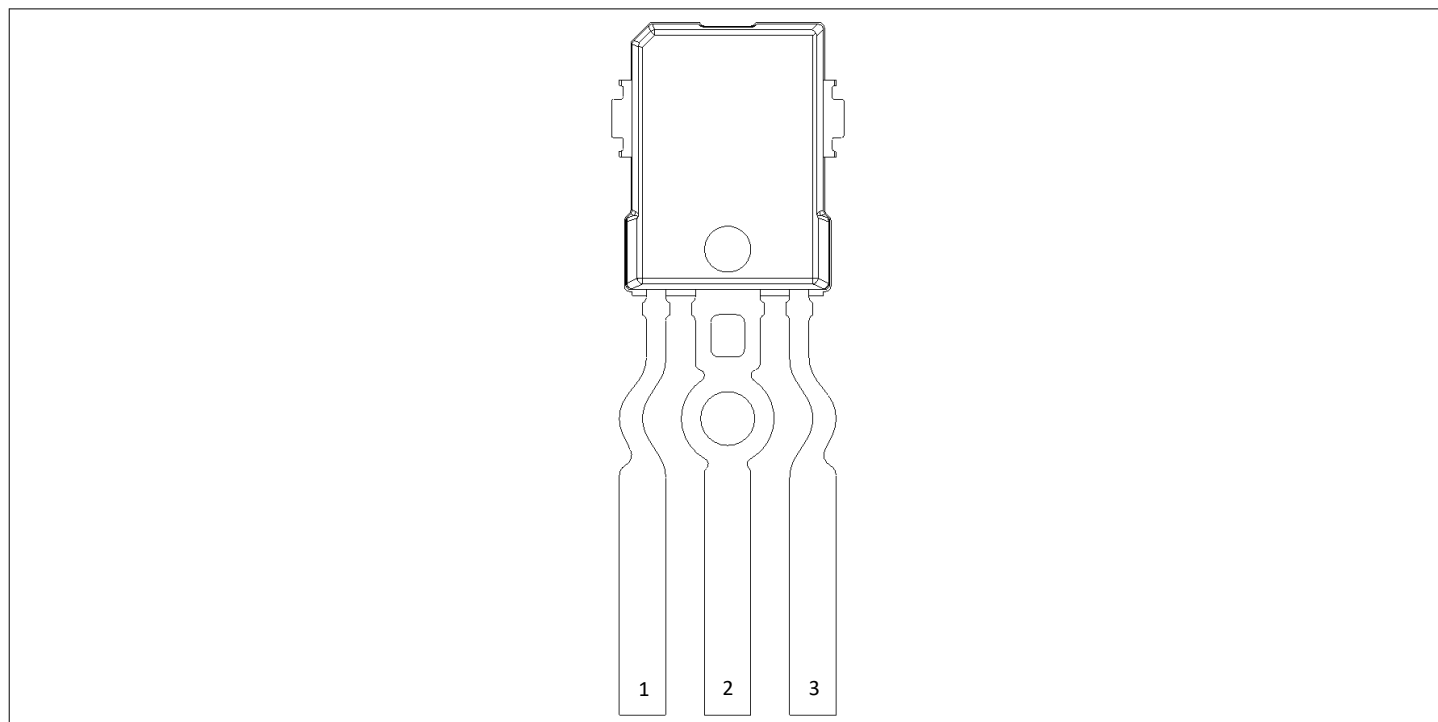

Figure 2 PG-SSO-3-41 Pin configuration

Table 2 Pin configuration PG-SSO-3-41

PIN number	Symbol	Description
1	n.c.	Not connected
2	GND	Ground
3	VDD	Supply voltage / PSI5 interface / programming interface

3 General product characteristics

3.1 Absolute Maximum Ratings

Table 3 Absolute maximum ratings

Parameter	Symbol	Values			Unit	Note or condition
		Min.	Typ.	Max.		
Maximum supply voltage	V_{DD_max}	-21	-	26	V	max. 1 min @ $T_J = 175^\circ\text{C}$ or max. 1 h @ $T_J = 100^\circ\text{C}$
Voltage peaks VDD	V_{DD_peak}	-	-	30	V	max. 50 μs , no current limitation
Maximum pin-to-pin voltage difference	V_{PP_max}	-	-	26	V	for neighboring pins
Maximum current VDD	I_{DD_max}	-105	-	50	mA	max. 40 h; current < 0 means short to V_{DD}
Maximum ambient temperature	T_{A_max}	-40	-	150	$^\circ\text{C}$	max. 1000 h at $T_A=150^\circ\text{C}$ (not additive)
Maximum junction temperature	T_{J_max}	-40	-	175	$^\circ\text{C}$	max. 1000 h at $T_J=175^\circ\text{C}$ (not additive); maximum exposure time at other junction temperatures shall be calculated using the Arrhenius-model
Storage & shipment temperature	$T_{storage}$	5	-	40	$^\circ\text{C}$	for dry packed devices, relative humidity < 90%, storage time < 3a; see Infineon Application Note: “Storage of Products Supplied by Infineon Technologies”

3.2 ESD Immunity

Table 4 ESD immunity

Parameter	Symbol	Values			Unit	Note or condition
		Min.	Typ.	Max.		
HBM ESD immunity	V_{HBM}	-	-	± 4	kV	Electro-Static-Discharge voltage (HBM) according to AEC-Q100-002
CDM ESD immunity	V_{CDM}	-	-	± 0.75	kV	PG-SSO-3-41, the product withstands the specified Electro-Static-Discharge voltage (CDM) according to AEC-Q100-011

Note: Latchup robustness: class II according to AEC-Q100-04.

3.3 Stray Field Robustness

The sensor supports full stray field immunity according to ISO 11452-8:2015 test level IV, and above, see [table 5](#).

Table 5 Stray field robustness

Parameter	Symbol	Values			Unit	Note or condition
		Min.	Typ.	Max.		
Stray field robustness DC	B _{Ext_DC}	-8	-	8	mT	-
Stray field robustness AC	B _{Ext_AC}	-1.25	-	1.25	mT	according ISO 11452-8:2015

3.4 Lifetime and Ignition Cycles

Table 6 Lifetime and ignition cycles

Parameter	Symbol	Values			Unit	Note or condition
		Min.	Typ.	Max.		
Operating lifetime	t _{op_life}	15k	-	-	h	max. 1000 h at T _{J_max} = 175°C (not additive)
Total lifetime	t _{tot_life}	19	-	-	a	additional 3a storage time
Ignition cycles	N _{ignition}	54k	-	-		during operating lifetime t _{op_life}

3.5 Functional range

Table 7 Operating range

Parameter	Symbol	Values			Unit	Note or condition
		Min.	Typ.	Max.		
Operating junction temperature	T _J	-40	-	175	°C	max. 1000 h at T _J =175°C (not additive); maximum exposure time at other junction temperatures shall be calculated using the Arrhenius-model
Operating ambient temperature	T _A	-40	-	150	°C	max. 1000 h at T _A =150°C (not additive); Grade 0 qualification
Operating supply voltage	V _{DD}	5.0	-	11	V	-
Supply voltage slew rate	V _{DD_slew}	0.1	-	10 ⁸	V/s	the slew rate is the maximum voltage change per time and relates to the application circuit
Operating supply current	I _{DD}	4	13.5	16.5	mA	-
Angle range	α	0	-	360	°	-
Angular resolution	RES	0.022	-	-	°/bit	-

Table 8 Operating magnetic field range

Parameter	Symbol	Values			Unit	Note or condition
		Min.	Typ.	Max.		
Operating magnetic field	B _{op}	20	-	90	mT	magnetic field based on differential field; magnetic field component orthogonal to package surface
Extended operating magnetic field	B _{op_ext}	10	-	20	mT	magnetic field based on differential field; magnetic field component orthogonal to package surface. In extended operating range (between 10 to 20mT) a warning bit is active ¹⁾

1) In extended range the performances are further degraded due to a reduction of the signal-to-noise ratio and signal-to-offset ratio.

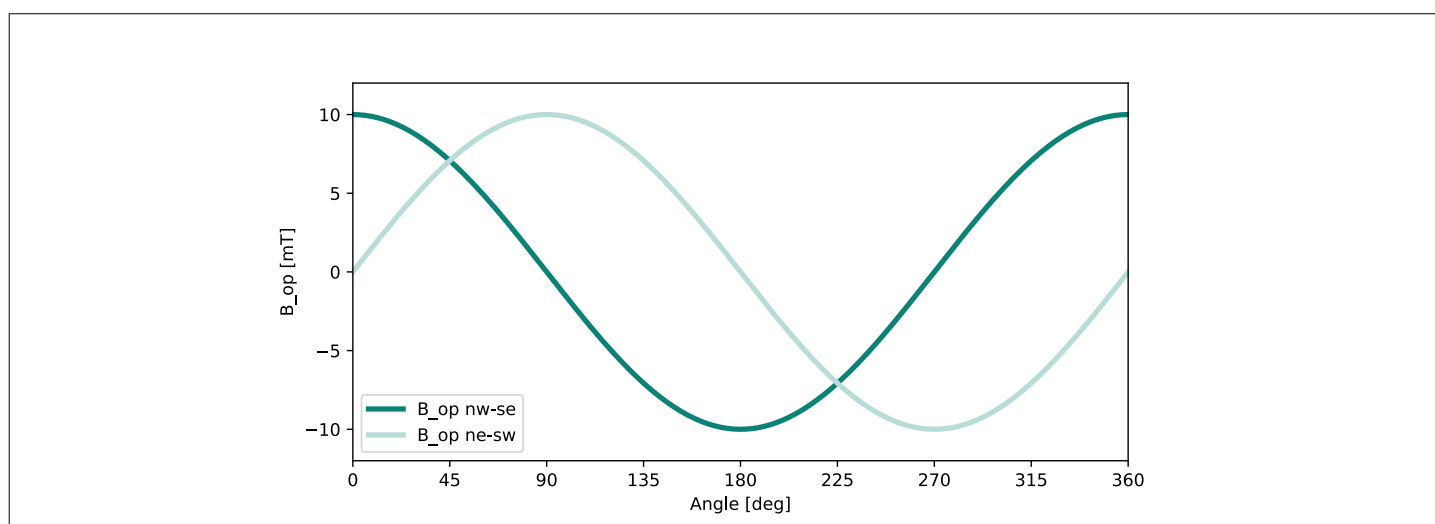

Figure 3 Operating magnetic field example

Table 9 Angle speed

Parameter	Symbol	Values			Unit	Note or condition
		Min.	Typ.	Max.		
Angle speed	n	-	-	10000	rpm	-
Angle speed total error	Δn	-3	-	3	%	for constant velocity at room temperature
Angle speed noise	n RMS	-	-	5	rpm	

Table 10 Angle speed signal attributes

Angle speed mode	vα1	vα2	vα3	vα4	Unit
Measurement range max	± 1000	± 5000	± 4606	± 180000	°/s
Signal Resolution	12	12	16	16	bit

(table continues...)

Table 10 (continued) Angle speed signal attributes

Angle speed mode	vα1	vα2	vα3	vα4	Unit
Latency time	1.0	1.0	1.0	0.5	ms

3.6 Thermal Resistance

Table 11 Thermal resistance

Parameter	Symbol	Values			Unit	Note or condition
		Min.	Typ.	Max.		
Thermal resistance junction to ambient	R _{thJA}	-	150	153	K/W	

4 Product features

4.1 Functional description

4.1.1 Angle Accuracy

The intrinsic angle error includes all errors regarding the IC itself and does not consider mechanical or magnetic tolerances. The mechanic or magnetic tolerances increase the angle error, but can be compensated by an end-of-line multi-point calibration.

Table 12 Angle accuracy

Parameter	Symbol	Values			Unit	Note or condition
		Min.	Typ.	Max.		
Intrinsic angle error	AE _{INL}	-	-	0.8	°	including offset, sensitivity mismatch over temperature assuming an ideal magnetic field
Intrinsic angle error in extended magnetic range	AE _{INL_EXT}	-	-	1.25	°	including offset, sensitivity mismatch over temperature assuming an ideal magnetic field ¹⁾
Intrinsic angle accuracy lifetime drift	AE _{drift}	-	-	0.2	°	-
Output noise (RMS)	OUT _{noise_1k} 5Hz	-	0.05	0.1	°	for LP-Filter setting 8, 20 mT magnetic induction and T _{amb} =25°C

¹⁾ The calculation is derived from characterization and error modeling.

4.1.2 Interface timing

PSI5 interface timing

The following figure shows the interface timing overview starting with the trigger event of the PSI5 interface. The raw data is continuously filtered based on the configured filter characteristic and sampled with the rising edge of the received trigger respectively sync pulse. As soon as the sync pulse is determined to be long enough the angle calculation using the CORDIC algorithm is started and the output protocol is generated. In this way, a constant delay of the angle data in respect to the trigger event is achieved.

4 Product features

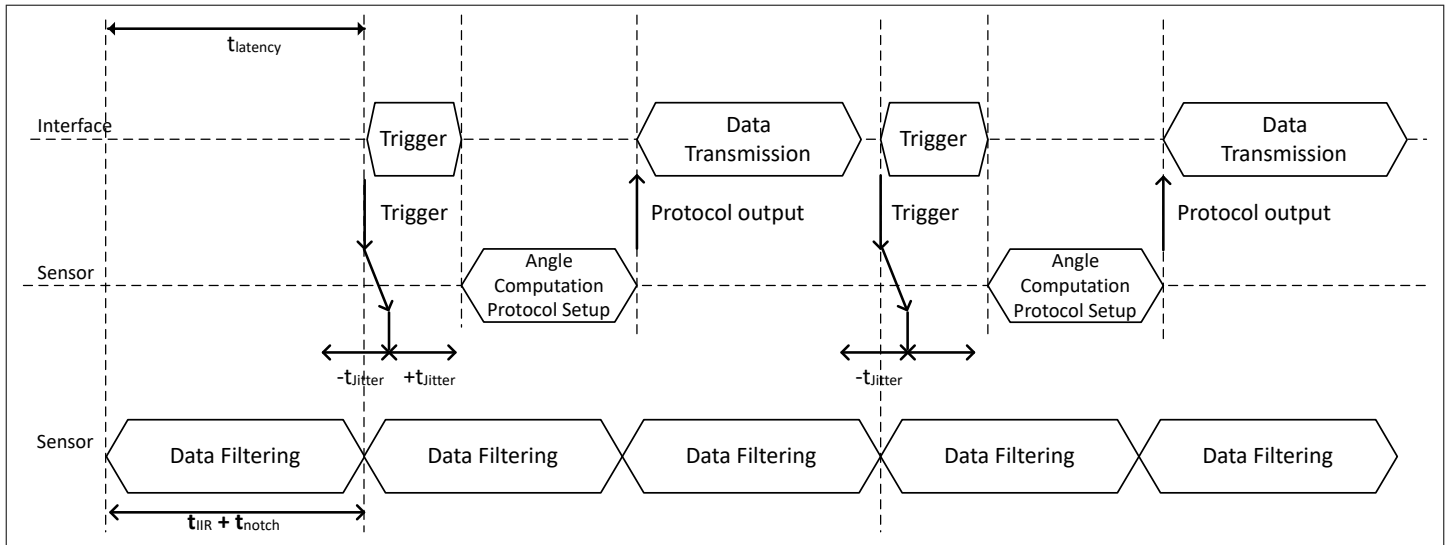

Figure 4 **PSI5 interface timing overview**

Latency time description

The latency time ($t_{latency}$) is obtained by the adding the jitter delay time, the notch filter delay and the signal filter delay: $t_{latency} = t_{jitter} + t_{notch} + t_{IIR}$ (μs).

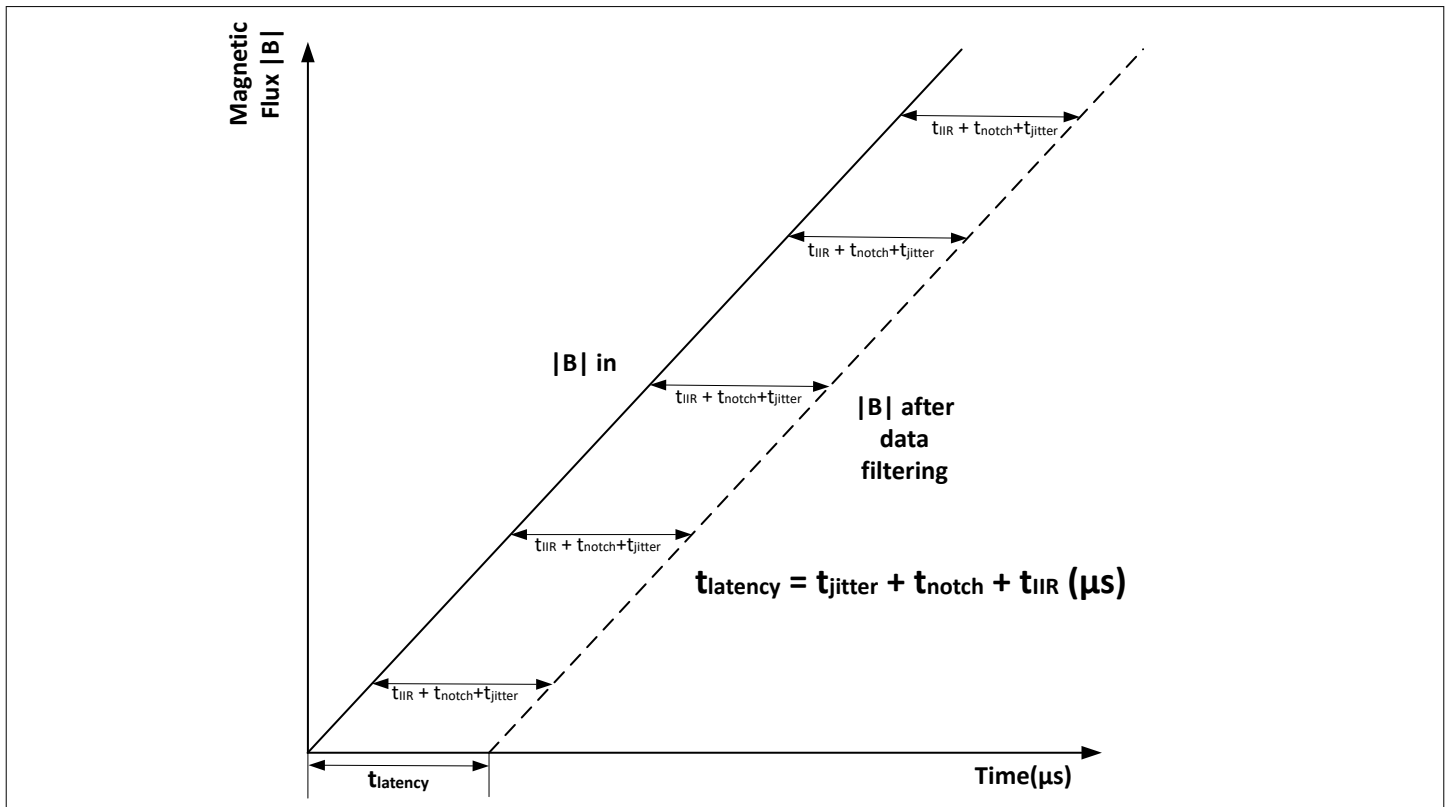

Figure 5 **Latency time description**

Signal filter time configuration

The sensor allows a configuration of the filter (delay) time through setting the corresponding filter constant k_{filter} .

Table 13 Signal and jitter delay time

Parameter	Symbol	Values			Unit	Note or condition
		Min.	Typ.	Max.		
Jitter delay time	t_{jitter}	-1	-	1	μs	not including interface transmission
Signal filter delay	t_{IIR}	-	-	-	μs	filter setting delay, see Signal filter time configuration
Notch filter delay	t_{notch}	-	-	4.8	μs	
Latency time	t_{latency}	-	-	9.8	μs	for LP-setting 1, see Latency time description

Table 14 Signal filter time configuration

Parameter	Symbol	Values			Unit	Note or condition
		Min.	Typ.	Max.		
Filter setting 1	k_{filter1}	-	-	4	μs	49.2 kHz
Filter setting 2	k_{filter2}	-	-	6.2	μs	32.5 kHz
Filter setting 3	k_{filter3}	-	-	8.3	μs	24.3 kHz
Filter setting 4	k_{filter4}	-	-	12.6	μs	16.1 kHz
Filter setting 5	k_{filter5}	-	-	16.8	μs	12 kHz
Filter setting 6	k_{filter6}	-	-	25.4	μs	8 kHz
Filter setting 7	k_{filter7}	-	-	51	μs	4 kHz
Filter setting 8	k_{filter8}	-	-	136	μs	1.5 kHz (default)
Filter setting 9	k_{filter9}	-	-	204	μs	1 kHz
Filter setting 10	k_{filter10}	-	-	272	μs	0.75 kHz
Filter setting 11	k_{filter11}	-	-	409	μs	0.5 kHz
Filter setting 12	k_{filter12}	-	-	546	μs	0.375 kHz
Filter setting 13	k_{filter13}	-	-	819	μs	0.25 kHz
Filter setting 14	k_{filter14}	-	-	1.64	ms	125 Hz
Filter setting 15	k_{filter15}	-	-	2.18	ms	93 Hz
Filter setting 16	k_{filter16}	-	-	3.27	ms	62 Hz
Filter setting 17	k_{filter17}	-	-	4.36	ms	47 Hz
Filter setting 18	k_{filter18}	-	-	6.54	ms	31 Hz
Filter setting 19	k_{filter19}	-	-	8.72	ms	23 Hz
Filter setting 20	k_{filter20}	-	-	13.1	ms	15 Hz
Filter setting 21	k_{filter21}	-	-	26	ms	7.8 Hz

4.2 Electrical characteristics

Table 15 Electrical characteristics

Parameter	Symbol	Values			Unit	Note or condition
		Min.	Typ.	Max.		
Power-on time	t_{PON}	2	-	198	ms	time until the sensor is ready for operation after start-up or reset; configurable with a resolution of 192 μ s steps
Internal clock tolerance	Δf_{clock}	-3.5	-	3.5	%	including temperature and lifetime

4.3 Internal circuitry for PG-SSO-3-41

Table 16 Internal circuitry for PG-SSO-3-41

Parameter	Symbol	Values			Unit	Note or condition
		Min.	Typ.	Max.		
Capacitance at VDD	C_{VDD}	5.1	6.8	8.5	nF	PG-SSO-3-41, PSI5
Capacitance at CBUF	C_{BUF}	51	68	85	nF	PG-SSO-3-41

5 Specific module descriptions

5.1 Diagnostic functions

5.1.1 Magnetic field out of range

The sensor indicates a magnetic field out of the specified range through an error indication in the status bit. A detailed error description is provided by the diagnostic range bits from the PSI5 error protocol.

5.1.2 Under- and overvoltage condition

Table 17 Undervoltage and overvoltage conditions

Parameter	Symbol	Values			Unit	Note or condition
		Min.	Typ.	Max.		
Undervoltage detection on VDD	V_{UV}	3.2	-	4.1	V	below this level no protocol is transmitted
Overvoltage detection on VDD	V_{OV}	16.5	-	21.5	V	above this level no protocol is transmitted
Undervoltage reset time	t_{UV}	-	-	50	μ s	time below threshold for the sensor to initiate a safe reaction
Undervoltage hysteresis	V_{UV_hyst}	300	280	500	mV	-
Overvoltage hysteresis	V_{OV_hyst}	1	1.5	2	V	-
Overvoltage reaction time	t_{OV_RT}	-	-	50	μ s	time to react to overvoltage condition and disable output
Overvoltage recovery time	t_{OV}	-	-	50	μ s	time after overvoltage condition to enable protocol output
Undervoltage reaction time	t_{UV_RT}	-	-	50	μ s	time to react to undervoltage condition, and disable output
Undervoltage recovery time	t_{UV_RT}	-	-	50 + filter delay	μ s	time after undervoltage condition to enable protocol output

5.2 Interfaces

5.2.1 PSI5 Interface

The sensor supports a PSI5 interface according to base standard V2.3 and the substandard chassis and safety V2.3. In addition the basic operation modes of the PSI5 V1.3 specification are supported.

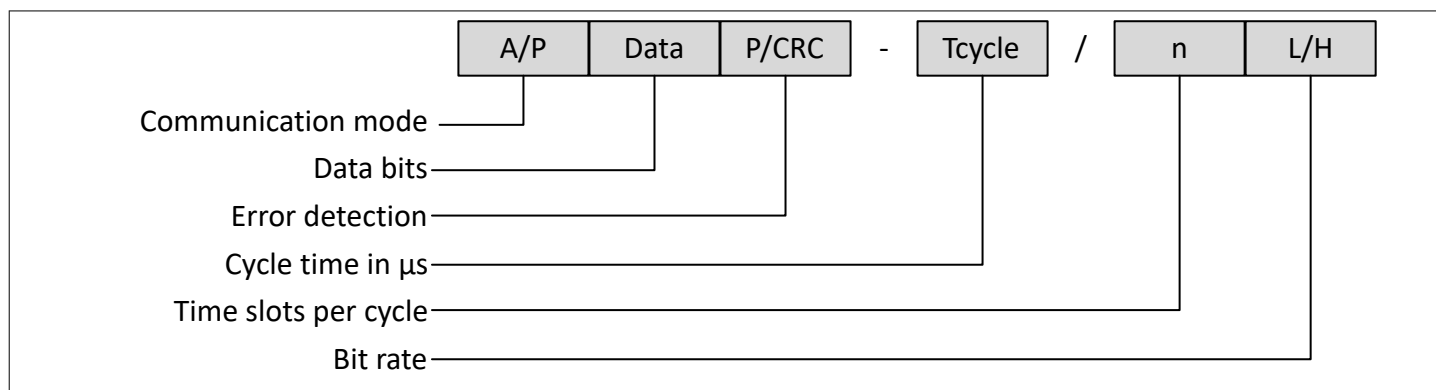

Figure 6 PSI5 operation modes denomination

The PSI5 mode denomination is defined by:

- Operation mode:
 - A: Asynchronous
 - P: Synchronous parallel bus
- Number of bits:
 - 10 bits
 - 10 bits high resolution
 - 16 bits
 - 20 bits
- Error detection:
 - P: One parity bit
 - CRC: 3 bits cyclic redundancy check
- Cycle time in µs:
 - 200 µs
 - 300 µs
 - 400 µs
 - 500 µs
 - 1 ms
- Number of time slots per cycle:
 - 1 to 4, individually configurable
- Bit rate:
 - L: 125 kbps
 - H: 189 kbps

5.2.1.1 PSI5 current modulation

The PSI5 interface transmits data via current modulation of the power supply. The quiescent current I_{s_low} represents the normal current consumption of the sensor. At I_{s_high} a data communication is generated by an increased current sink of the sensor. The data frame uses Manchester coding. A rising slope is a logic "0", whereas a falling slope represents a logic "1".

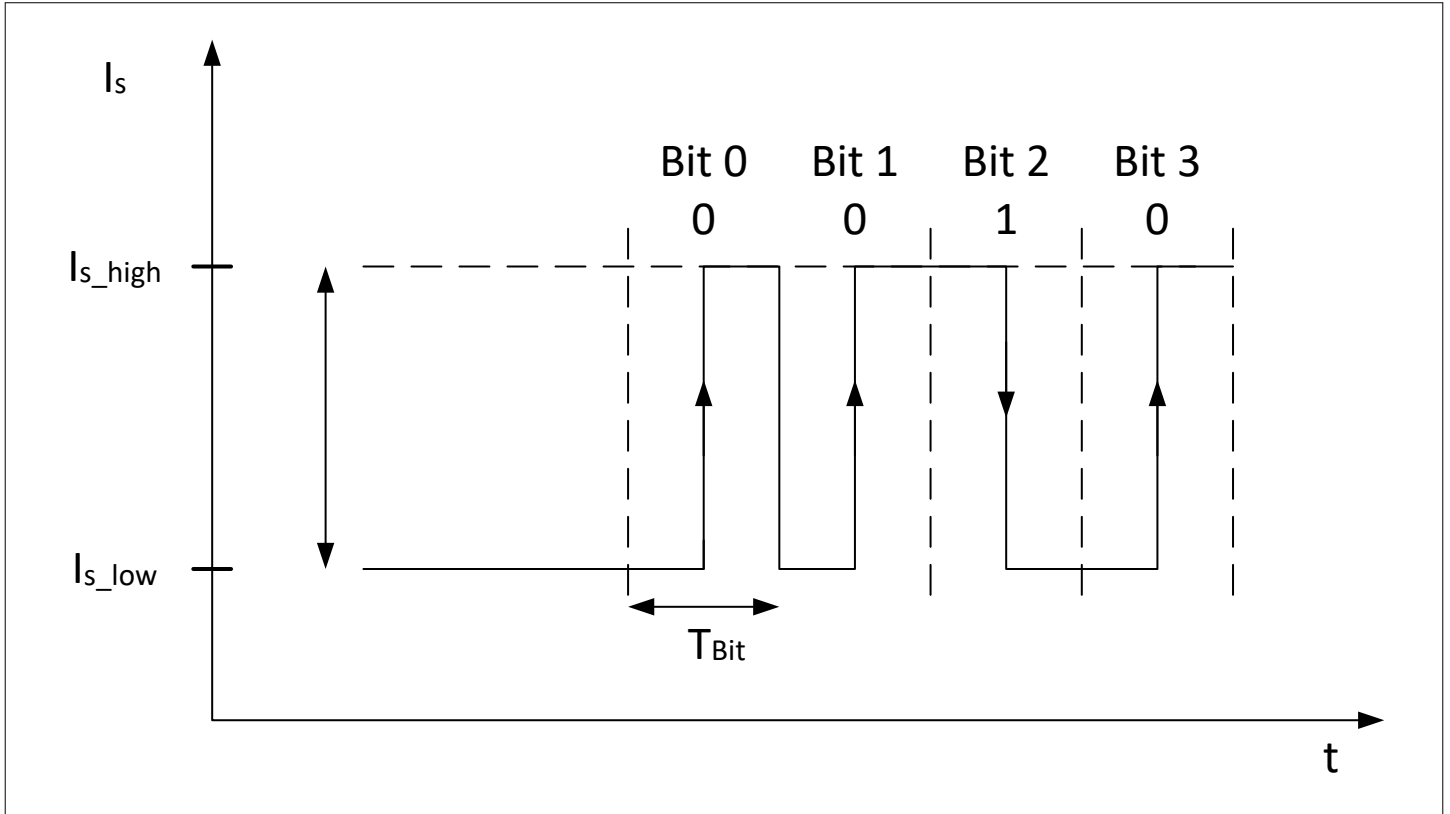

Figure 7 PSI5 current modulation with Manchester coding

Table 18 PSI5 current modulation parameters

Parameter	Symbol	Values			Unit	Note or condition
		Min.	Typ.	Max.		
Sink current	ΔI_{s_cm}	22	26	30	mA	Common mode
Sink current	ΔI_{s_lp}	11	13	15	mA	Low power mode
Quiescent current drift rate	$Drift_{I_s}$	0		10	mA/s	Measured after 1st order high-pass filter with corner frequency $f_{c_1}=1\text{Hz}$

Table 19 PSI5 timing parameters

Parameter	Symbol	Values			Unit	Note or condition
		Min.	Typ.	Max.		
Cycle time	T_{cycle}	200		1000	μs	Programmable

(table continues...)

Table 19 (continued) PSI5 timing parameters

Parameter	Symbol	Values			Unit	Note or condition
		Min.	Typ.	Max.		
Bit time high speed	$T_{\text{Bit_high}}$	5.0	5.3	5.6	μs	189 kbit/s (high speed)
Bit time low speed	$T_{\text{Bit_low}}$	7.6	8	8.4	μs	125 kbit/s (low speed)
Mark/Space Ratio at Sensor	MSR	47	50	53	%	$(t_{\text{fall}, 80} - t_{\text{rise}, 20}) / T_{\text{Bit}}$ $(t_{\text{fall}, 20} - t_{\text{rise}, 80}) / T_{\text{Bit}}$
Rising time current modulation	T_{Rise}	0.33	-	1	μs	20% to 80% of $\Delta I_S = (I_{S,\text{High}} - I_{S,\text{Low}})$
Falling time current modulation	T_{Fall}	0.33	-	1	μs	80% to 20% of $\Delta I_S = (I_{S,\text{High}} - I_{S,\text{Low}})$
Gap time high speed	T_{Gap}	5.6	5.9	-	μs	189 kbit/s mode
Gap time low speed	T_{Gap}	8.4	8.85	-	μs	125 kbit/s mode

5.2.1.2 Synchronization pulse

The synchronization (sync) pulse enables a common time base for all connected sensors. The ECU generates the sync pulse via a positive voltage modulation on the supply line. A short or long sync pulse is possible.

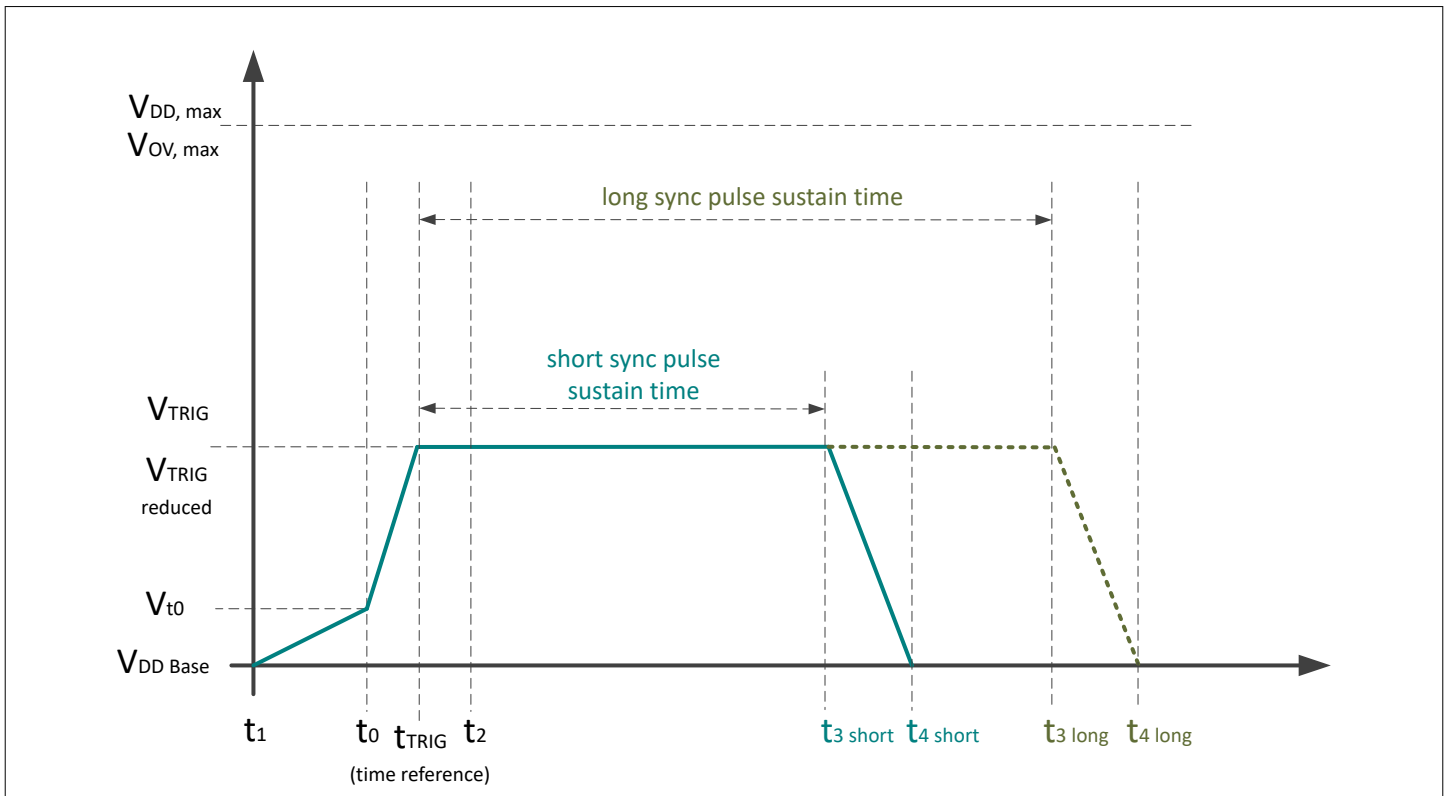

Figure 8 PSI5 synchronization pulse

Table 20 Synchronization pulse parameters

Parameter	Symbol	Values			Unit	Note or condition
		Min.	Typ.	Max.		
Threshold sensor trigger	V_{trig}	$V_{DD} + 1.4$	$V_{DD} + 2.0$	$V_{DD} + 2.6$	V	Standard sync pulse
Threshold reduced sensor trigger	V_{trig_red}	$V_{DD} + 1.2$	$V_{DD} + 1.5$	$V_{DD} + 1.8$	V	Reduced sync pulse
Sync pulse hold time short	T_{sync_short}	9	-	28	μs	
Sync pulse hold time long	T_{sync_long}	36	-	55	μs	

5.2.1.3 PSI5 Initialization modes

The initialization procedure is divided into three phases and the sensor only sends initialization data in phase 2 after each power-on reset or soft reset (if Normal Operation state wasn't reached before a soft reset - configurable in EEPROM) and thus before any effective sensor data is sent. For phase 2 a data message repetition count factor k of 4 is typically used, which however is configurable for the customer.

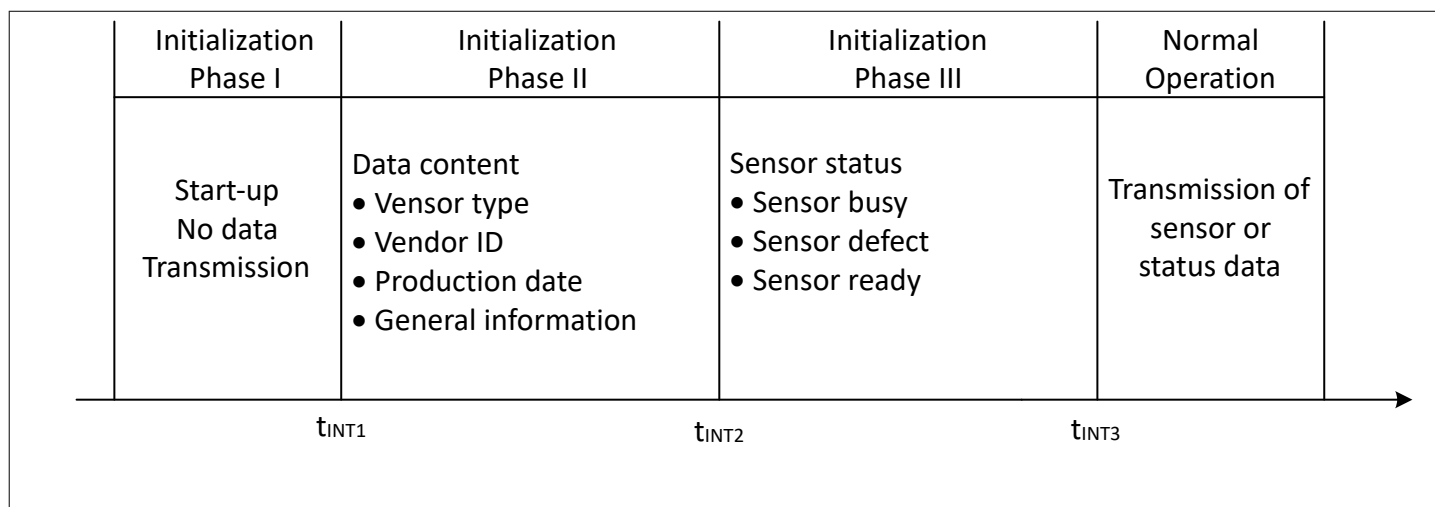

Figure 9 Sensor Initialization phases

PSI5 Meta Information Initialization

In cases where sensors from different application fields are connected to one bus system (e.g. powertrain and chassis and safety sensors) the interoperability of the different protocols is guaranteed by an optional “meta information” header that transmitted minimum once at the very beginning of the identification phase indicating the PSI5 version and the method used for identification data transmission. Irrespective of the applied identification procedure the header data field is sent in status data format (10-Bit value out of data range 3). For systems that use the Data Range Initialization* the meta header is mandatory and consists of at least one identifier (ID1) and one data nibble (D1).

Note: The TLE49SRI3 only supports Data Range initialization.

Selectable initialization phase switch-off feature

The actual startup time for the initialization phase 1 is programmable. The number of frames transmitted during phase 2 as well as during phase 3 are programmable. In addition, if for phase 2 or phase 3 zero frames are selected (i.e. programmed) the corresponding phase is omitted from the startup procedure.

5.2.1.4 Slot ID definition

The assignment of angle data, angle speed data and temperature data can be configured for up to four individual slots per cycle. The slot ID data content is defined in the sensor EEPROM. If all slots have "none" as configuration (i.e. a wrong configuration) the sensor uses slot 1 as default angle data output.

During the PSi5 initialization phase all selected slots transmit the same data for one sync pulse. This is done to ensure that a sensor with multiple configured slots takes the same amount of time for the startup procedure as a sensor with only one slot.

5.2.1.5 Frame control

Whenever a valid sync pulse is detected the frame control is incremented by 1 with an automatic wrap-around of the counter above 7.

If the sync pulse was invalid, the frame control does not get incremented.

If several slots are transmitted, then all of these slots will have the same frame control.

5.2.1.6 Transmission Modes

The sensor supports PSi5 asynchronous mode (A) and synchronous parallel bus mode (P). In asynchronous mode, the sensor transmits data periodically based on the configured cycle time. Whereas in synchronous mode the sensor transmission is triggered by the ECU by means of emitting a sync pulse.

5.2.1.6.1 Asynchronous mode

Unidirectional, asynchronous data transmission. Each sensor is connected to the ECU by two wires. After switching on the power supply, the sensor starts transmitting data to the ECU periodically. Timing and repetition rate of the data transmission are controlled by the sensor.

5.2.1.6.2 P10P mode

The initialization phase II of each PSi5 mode is different. Additionally, each frame can be repeated up to 4 times, which is defined in the repetition factor k. The initialization phase II of P10P mode is shown in the following figure.

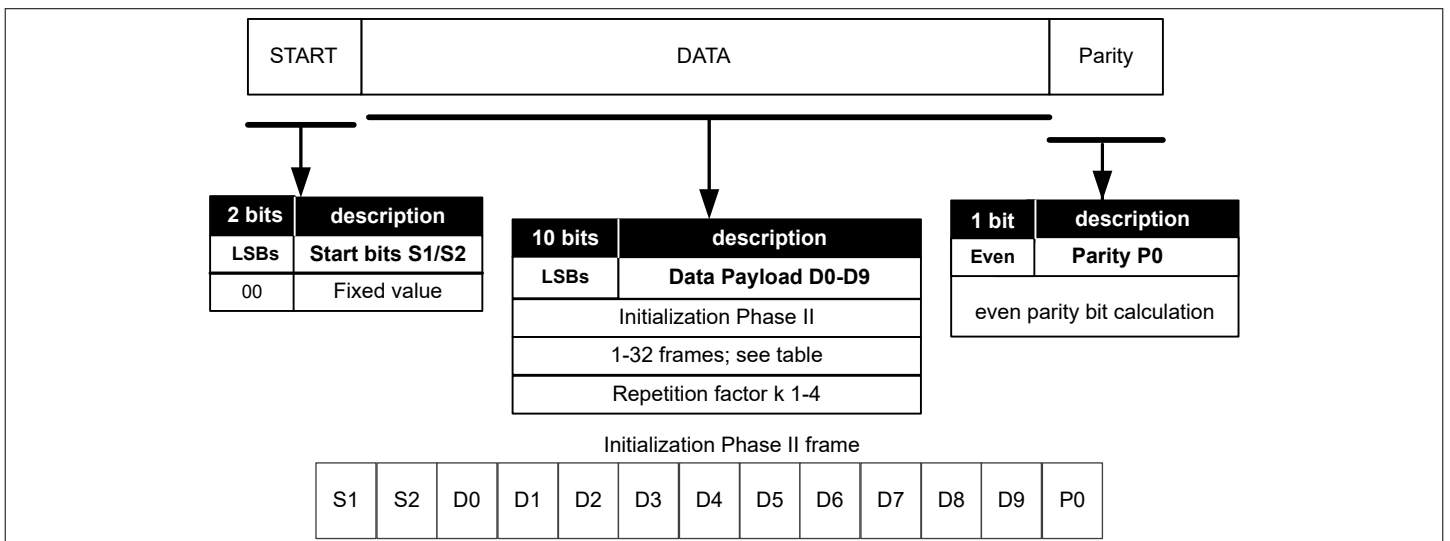

Figure 10 P10P mode initialization phase II

P10P mode initialization phase II data content

Frame 0-31 of the initialization phase II are defined in below table:

Table 21 P10P mode initialization phase II data content

Frame	Description	Bitmap Bitfield / Data	Bitfield Bits	D0	D1	D2	D3	D4	D5	D6	D7	D8	D9
0	ID01	0000	-	0	0	0	0	0	0	0	0	0	1
0	PSI5 Version (0110 = PSI5 v2.3)	0110	3:0	x	x	x	x	1	0	0	0	0	1
1	ID02	0001	-	1	0	0	0	0	0	0	0	0	1
1	Number of init frames to be transmitted (part 1)	eep_prot_psi5_init_frames ¹⁾	7:4	x	x	x	x	1	0	0	0	0	1
2	ID03	0010	-	0	1	0	0	0	0	0	0	0	1
2	Number of init frames to be transmitted (part 2)	eep_prot_psi5_init_frames ¹⁾	3:0	x	x	x	x	1	0	0	0	0	1
3	ID04	0011	-	1	1	0	0	0	0	0	0	0	1
3	Vendor ID	eep_vendor_id	7:4	x	x	x	x	1	0	0	0	0	1
4	ID05	0100	-	0	0	1	0	0	0	0	0	0	1
4	Vendor ID	eep_vendor_id	3:0	x	x	x	x	1	0	0	0	0	1
5	ID06	0101	-	1	0	1	0	0	0	0	0	0	1
5	Sensor Type (part 1)	eep_sensor_type	7:4	x	x	x	x	1	0	0	0	0	1
6	ID07	0110	-	0	1	1	0	0	0	0	0	0	1
6	Sensor Type (part 2)	eep_sensor_type	3:0	x	x	x	x	1	0	0	0	0	1
7	ID08	0111	-	1	1	1	0	0	0	0	0	0	1
7	User ID (part 1)	eep_usr_id_1	3:0	x	x	x	x	1	0	0	0	0	1
8	ID09	1000	-	0	0	0	1	0	0	0	0	0	1
8	User ID (part 2)	eep_usr_id_0	15:12	x	x	x	x	1	0	0	0	0	1
9	ID10	1001	-	1	0	0	1	0	0	0	0	0	1
9	User ID (part 3)	eep_usr_id_0	11:8	x	x	x	x	1	0	0	0	0	1
10	ID11	1010	-	0	1	0	1	0	0	0	0	0	1
10	User ID (part 4)	eep_usr_id_0	7:4	x	x	x	x	1	0	0	0	0	1
11	ID12	1011	-	1	1	0	1	0	0	0	0	0	1
11	User ID (part 5)	eep_usr_id_0	3:0	x	x	x	x	1	0	0	0	0	1
12	ID13	1100	-	0	0	1	1	0	0	0	0	0	1
12	Production date (part 1)	eep_usr_prot_date	15:12	x	x	x	x	1	0	0	0	0	1
13	ID14	1101	-	1	0	1	1	0	0	0	0	0	1
13	Production date (part 2)	eep_usr_prot_date	11:8	x	x	x	x	1	0	0	0	0	1
14	ID15	1110	-	0	1	1	1	0	0	0	0	0	1

(table continues...)

Table 21 (continued) P10P mode initialization phase II data content

Frame	Description	Bitmap Bitfield / Data	Bitfield Bits	D0	D1	D2	D3	D4	D5	D6	D7	D8	D9
14	Production date (part 3)	eep_usr_prot_date	7:4	x	x	x	x	1	0	0	0	0	1
15	ID16	1111	-	1	1	1	1	0	0	0	0	0	1
15	Production date (part 4)	eep_usr_prot_date	3:0	x	x	x	x	1	0	0	0	0	1
16	ID01	0000	-	0	0	0	0	0	0	0	0	0	1
16	Wafer X Coordinates (part 1)	eep_wafer_x_coord	7:4	x	x	x	x	1	0	0	0	0	1
17	ID02	0001	-	1	0	0	0	0	0	0	0	0	1
17	Wafer X Coordinates (part 2)	eep_wafer_x_coord	3:0	x	x	x	x	1	0	0	0	0	1
18	ID03	0010	-	0	1	0	0	0	0	0	0	0	1
18	Wafer Y Coordinates (part 1)	eep_wafer_y_coord	7:4	x	x	x	x	1	0	0	0	0	1
19	ID04	0011	-	1	1	0	0	0	0	0	0	0	1
19	Wafer Y Coordinates (part 2)	eep_wafer_y_coord	3:0	x	x	x	x	1	0	0	0	0	1
20	ID05	0100	-	0	0	1	0	0	0	0	0	0	1
20	Wafer Lot Number (part 1)	eep_lot_wafer_nr	5:4	x	x	0	0	1	0	0	0	0	1
21	ID06	0101	-	1	0	1	0	0	0	0	0	0	1
21	Wafer Lot Number (part 2)	eep_lot_wafer_nr	3:0	x	x	x	x	1	0	0	0	0	1
22	ID07	0110	-	0	1	1	0	0	0	0	0	0	1
22	Lot Serial Number (part 1)	eep_lot_serial_19_10	9:6	x	x	x	x	1	0	0	0	0	1
23	ID08	0111	-	1	1	1	0	0	0	0	0	0	1
23	Lot Serial Number (part 2)	eep_lot_serial_19_10	5:2	x	x	x	x	1	0	0	0	0	1
24	ID09	1000	-	0	0	0	1	0	0	0	0	0	1
24	Lot Serial Number (part 3)	eep_lot_serial_19_10 eep_lot_serial_9_0	1:0 9:8	x	x	x	x	1	0	0	0	0	1
25	ID10	1001	-	1	0	0	1	0	0	0	0	0	1
25	Lot Serial Number (part 4)	eep_lot_serial_9_0	7:4	x	x	x	x	1	0	0	0	0	1
26	ID11	1010	-	0	1	0	1	0	0	0	0	0	1
26	Lot Serial Number (part 5)	eep_lot_serial_9_0	3:0	x	x	x	x	1	0	0	0	0	1
27	ID12	1011	-	1	1	0	1	0	0	0	0	0	1
27	Fab Location	eep_fab_location	1:0	x	x	0	0	1	0	0	0	0	1
28	ID13	1100	-	0	0	1	1	0	0	0	0	0	1
28	Bitmap ID	eep_bitmap_id	3:0	x	x	x	x	1	0	0	0	0	1
29	ID14	1101	-	1	0	1	1	0	0	0	0	0	1

(table continues...)

Table 21 (continued) P10P mode initialization phase II data content

Frame	Description	Bitmap Bitfield / Data	Bitfield Bits	D0	D1	D2	D3	D4	D5	D6	D7	D8	D9
29	Unused	0000	-	0	0	0	0	1	0	0	0	0	1
30	ID15	1110	-	0	1	1	1	0	0	0	0	0	1
30	Unused	0000	-	0	0	0	0	1	0	0	0	0	1
31	ID16	1111	-	1	1	1	1	0	0	0	0	0	1
31	Unused	0000	-	0	0	0	0	1	0	0	0	0	1

¹⁾ eep_prot_psi5_init2_frames is clamped to a maximum value of 32 if a higher value is programmed, because this is the maximum amount of frames that will be transmitted

P10P mode initialization phase III data content

The bits D9 to D0 will contain the sensor status which can have one of the following three values depending on the error flag status:

Table 22 Frames of the initialization phase III

Sensor Status	Data	D0	D1	D2	D3	D4	D5	D6	D7	D8	D9
SENSOR_BUSY	0x1E8	0	0	0	1	0	1	1	1	1	0
SENSOR_DEFECT	0x1F4	0	0	1	0	1	1	1	1	1	0
SENSOR_READY	0x1E7	1	1	1	0	0	1	1	1	1	0

P10P normal operation mode

The normal operation of P10P mode supports 3 different frame formats:

- 10 Bit angle data
- 10 Bit angle speed data
- 8 Bit temperature data

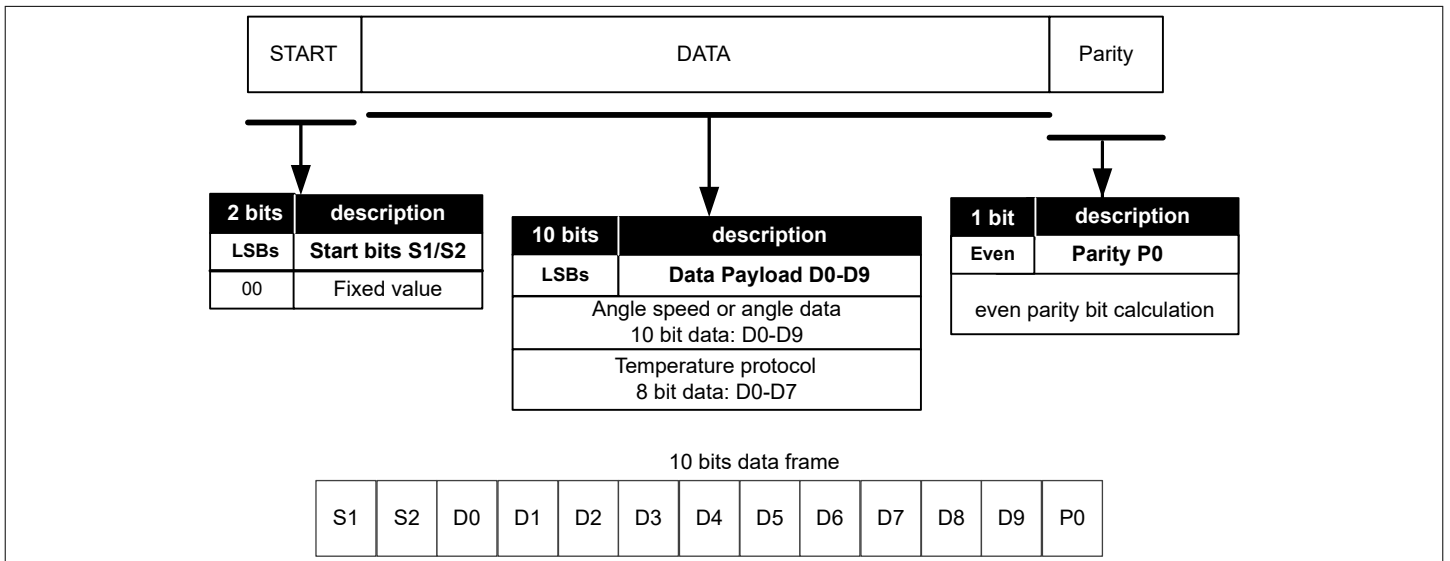

Figure 11 P10P mode in normal operation

Due to the limited protocol bits, this protocol only has 1 variant available for the normal operation.

P10P data mode	Data [LSB]	Bitfield bits	D0	D1	D2	D3	D4	D5	D6	D7	D8	D9	Angle resolution
10 bit	angle value	15:6	6	7	8	9	10	11	12	13	14	15	0.375°/LSB

Figure 12 P10P angle protocol data

Note: The angle value is scaled to fit the value range of [-480, 480] according to the PSI5 standard.

The angle speed protocol depends on the selected angle speed transmission mode.

P10P angle speed mode	Data [LSB]	Bitfield bits	D0	D1	D2	D3	D4	D5	D6	D7	D8	D9	Angle speed resolution
va1 (+-1000 °/s)	angle speed value	11:02	2	3	4	5	6	7	8	9	10	11	2.083°/s/LSB
va2 (+-5000 °/s)	angle speed value	11:02	2	3	4	5	6	7	8	9	10	11	10.417°/s/LSB
va3 (+-4606°/s)	angle speed value	15:06	6	7	8	9	10	11	12	13	14	15	9.596°/s/LSB
va4 (+-180000°/s)	angle speed value	15:06	6	7	8	9	10	11	12	13	14	15	375°/s/LSB

Figure 13 P10P angle speed protocol data

The temperature protocol transmits the complete 8 bits from the internal temperature

P10P Temperature	Data [LSB]	Bitfield bits	D0	D1	D2	D3	D4	D5	D6	D7	Angle resolution
8 bit	Temperature	7:0	0	1	2	3	4	5	6	7	1°C/LSB

Figure 14 P10P temperature data

P10P error mode

For the P10 definition no dedicated error condition protocol is defined. Instead, the protocol makes use of the PSI5 data range and thus error information is indicated by values in the status and error messages range. See [P10P mode initialization phase III data content](#)

5.2.1.6.3 P10 high resolution

The P10 high resolution mode means that two 10 bit frames (i.e. assigned to two adjacent slots) are combined to transmit 12 bit content (angle, angle speed or temperature). A dedicated bit is introduced to indicate low or high byte frames. The order is high byte first, then low byte.

In order to use the P10 high resolution mode two adjacent slots have to be assigned with the same data content (e.g. slot 1 and slot 2 with angle data; other options are angle speed or temperature).

P10 high resolution mode initialization phase II data content

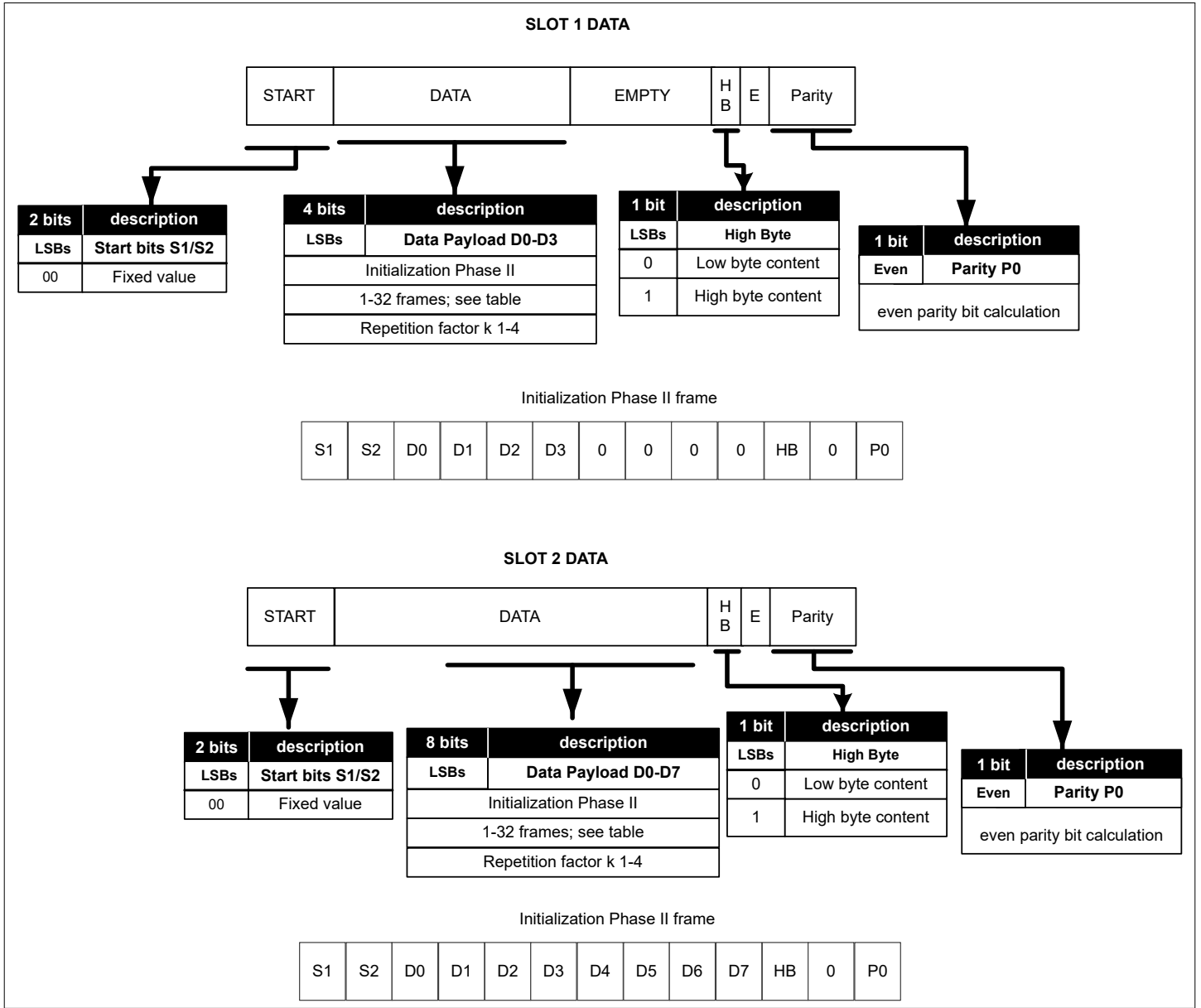

Figure 15 P10 High resolution mode initialization phase II

Note: The 12 bit initialization data is split between the high byte and low byte. This means that the first most significant 4 bits are transmitted on the bits D0 to D3 from the first slot and the remaining 8 least significant bits of the 12 bit initialization data are transmitted on the bits D0 to D7 from the second slot as indicated in the first row.

Frame 0-31 of the initialization phase II are defined in following table:

Table 23 P10 High resolution mode initialization phase II data content

Frame	Description	Bitmap Bitfield / Data	Bitfield Bits	Slot 1				Slot 2								
				D0	D1	D2	D3	D0	D1	D2	D3	D4	D5	D6	D7	
0	ID01	0000	-	0	0	0	1	0	0	0	0	0	0	0	0	0

(table continues...)

Table 23 (continued) P10 High resolution mode initialization phase II data content

Frame	Description	Bitmap Bitfield / Data	Bitfield Bits	Slot 1				Slot 2							
				D0	D1	D2	D3	D0	D1	D2	D3	D4	D5	D6	D7
0	PSI5 Version (0110 = PSI5 v2.3)	0110	3:0	0	0	0	1	0	0	x	x	x	x	1	0
1	ID02	0001	-	0	0	0	1	0	0	1	0	0	0	0	0
1	Number of init frames to be transmitted (part 1)	eep_prot_psi5_init 2_frames ¹⁾	7:4	0	0	0	1	0	0	x	x	x	x	1	0
2	ID03	0010	-	0	0	0	1	0	0	0	1	0	0	0	0
2	Number of init frames to be transmitted (part 2)	eep_prot_psi5_init 2_frames ¹⁾	3:0	0	0	0	1	0	0	x	x	x	x	1	0
3	ID04	0011	-	0	0	0	1	0	0	1	1	0	0	0	0
3	Vendor ID	eep_vendor_id	7:4	0	0	0	1	0	0	x	x	x	x	1	0
4	ID05	0100	-	0	0	0	1	0	0	0	0	1	0	0	0
4	Vendor ID	eep_vendor_id	3:0	0	0	0	1	0	0	x	x	x	x	1	0
5	ID06	0101	-	0	0	0	1	0	0	1	0	1	0	0	0
5	Sensor Type (part 1)	eep_sensor_type	7:4	0	0	0	1	0	0	x	x	x	x	1	0
6	ID07	0110	-	0	0	0	1	0	0	0	1	1	0	0	0
6	Sensor Type (part 2)	eep_sensor_type	3:0	0	0	0	1	0	0	x	x	x	x	1	0
7	ID08	0111	-	0	0	0	1	0	0	1	1	1	0	0	0
7	User ID (part 1)	eep_usr_id_1	3:0	0	0	0	1	0	0	x	x	x	x	1	0
8	ID09	1000	-	0	0	0	1	0	0	0	0	0	1	0	0
8	User ID (part 2)	eep_usr_id_0	15:12	0	0	0	1	0	0	x	x	x	x	1	0
9	ID10	1001	-	0	0	0	1	0	0	1	0	0	1	0	0
9	User ID (part 3)	eep_usr_id_0	11:8	0	0	0	1	0	0	x	x	x	x	1	0
10	ID11	1010	-	0	0	0	1	0	0	0	1	0	1	0	0
10	User ID (part 4)	eep_usr_id_0	7:4	0	0	0	1	0	0	x	x	x	x	1	0
11	ID12	1011	-	0	0	0	1	0	0	1	1	0	1	0	0
11	User ID (part 5)	eep_usr_id_0	3:0	0	0	0	1	0	0	x	x	x	x	1	0
12	ID13	1100	-	0	0	0	1	0	0	0	0	1	1	0	0
12	Production date (part 1)	eep_usr_prot_date	15:12	0	0	0	1	0	0	x	x	x	x	1	0
13	ID14	1101	-	0	0	0	1	0	0	1	0	1	1	0	0
13	Production date (part 2)	eep_usr_prot_date	11:8	0	0	0	1	0	0	x	x	x	x	1	0
14	ID15	1110	-	0	0	0	1	0	0	0	1	1	1	0	0
14	Production date (part 3)	eep_usr_prot_date	7:4	0	0	0	1	0	0	x	x	x	x	1	0
15	ID16	1111	-	0	0	0	1	0	0	1	1	1	1	0	0

(table continues...)

Table 23 (continued) P10 High resolution mode initialization phase II data content

Frame	Description	Bitmap Bitfield / Data	Bitfield Bits	Slot 1				Slot 2							
				D0	D1	D2	D3	D0	D1	D2	D3	D4	D5	D6	D7
15	Production date (part 4)	eep_usr_prot_date	3:0	0	0	0	1	0	0	x	x	x	x	1	0
16	ID01	0000	-	0	0	0	1	0	0	0	0	0	0	0	0
16	Wafer X Coordinates (part 1)	eep_wafer_x_coord	7:4	0	0	0	1	0	0	x	x	x	x	1	0
17	ID02	0001	-	0	0	0	1	0	0	1	0	0	0	0	0
17	Wafer X Coordinates (part 2)	eep_wafer_x_coord	3:0	0	0	0	1	0	0	x	x	x	x	1	0
18	ID03	0010	-	0	0	0	1	0	0	0	1	0	0	0	0
18	Wafer Y Coordinates (part 1)	eep_wafer_y_coord	7:4	0	0	0	1	0	0	x	x	x	x	1	0
19	ID04	0011	-	0	0	0	1	0	0	1	1	0	0	0	0
19	Wafer Y Coordinates (part 2)	eep_wafer_y_coord	3:0	0	0	0	1	0	0	x	x	x	x	1	0
20	ID05	0100	-	0	0	0	1	0	0	0	0	1	0	0	0
20	Wafer Lot Number (part 1)	eep_lot_wafer_nr	5:4	0	0	0	1	0	0	x	x	0	0	1	0
21	ID06	0101	-	0	0	0	1	0	0	1	0	1	0	0	0
21	Wafer Lot Number (part 2)	eep_lot_wafer_nr	3:0	0	0	0	1	0	0	x	x	x	x	1	0
22	ID07	0110	-	0	0	0	1	0	0	0	1	1	0	0	0
22	Lot Serial Number (part 1)	eep_lot_serial_19_10	9:6	0	0	0	1	0	0	x	x	x	x	1	0
23	ID08	0111	-	0	0	0	1	0	0	1	1	1	0	0	0
23	Lot Serial Number (part 2)	eep_lot_serial_19_10	5:2	0	0	0	1	0	0	x	x	x	x	1	0
24	ID09	1000	-	0	0	0	1	0	0	0	0	0	1	0	0
24	Lot Serial Number (part 3)	eep_lot_serial_19_10 eep_lot_serial_9_0	1:0 9:8	0	0	0	1	0	0	x	x	x	x	1	0
25	ID10	1001	-	0	0	0	1	0	0	1	0	0	1	0	0
25	Lot Serial Number (part 4)	eep_lot_serial_9_0	7:4	0	0	0	1	0	0	x	x	x	x	1	0
26	ID11	1010	-	0	0	0	1	0	0	0	1	0	1	0	0
26	Lot Serial Number (part 5)	eep_lot_serial_9_0	3:0	0	0	0	1	0	0	x	x	x	x	1	0
27	ID12	1011	-	0	0	0	1	0	0	1	1	0	1	0	0
27	Fab Location	eep_fab_location	1:0	0	0	0	1	0	0	x	x	0	0	1	0
28	ID13	1100	-	0	0	0	1	0	0	0	0	1	1	0	0

(table continues...)

Table 23 (continued) P10 High resolution mode initialization phase II data content

Frame	Description	Bitmap Bitfield / Data	Bitfield Bits	Slot 1				Slot 2							
				D0	D1	D2	D3	D0	D1	D2	D3	D4	D5	D6	D7
28	Bitmap ID	eep_bitmap_id	3:0	0	0	0	1	0	0	x	x	x	x	1	0
29	ID14	1101	-	0	0	0	1	0	0	1	0	1	1	0	0
29	Unused	0000	-	0	0	0	1	0	0	0	0	0	0	1	0
30	ID15	1110	-	0	0	0	1	0	0	0	1	1	1	0	0
30	Unused	0000	-	0	0	0	1	0	0	0	0	0	0	1	0
31	ID16	1111	-	0	0	0	1	0	0	1	1	1	1	0	0
31	Unused	0000	-	0	0	0	1	0	0	0	0	0	0	1	0

¹⁾ eep_prot_psi5_init2_frames is clamped to a maximum value of 32 if a higher value is programmed, because this is the maximum amount of frames that will be transmitted

P10 high resolution mode initialization phase III data content

Table 24 Frames of the initialization phase III

Sensor Status	Data	Slot 1				Slot 2							
		D0	D1	D2	D3	D0	D1	D2	D3	D4	D5	D6	D7
SENSOR_BUSY	0x1E8	1	1	1	0	0	0	0	0	0	1	0	1
SENSOR_DEFECT	0x1F4	1	1	1	0	0	0	0	0	1	0	1	1
SENSOR_READY	0x1E7	1	1	1	0	0	0	1	1	1	0	0	1

Note: The original 10 bit value is scaled up to 12 bit (shift left by 2 bits).

P10 high resolution normal operation mode

The normal operation of P10 High resolution mode supports 3 different frame formats:

- 12 Bit angle data
- 12 Bit angle speed data
- 8 Bit temperature data

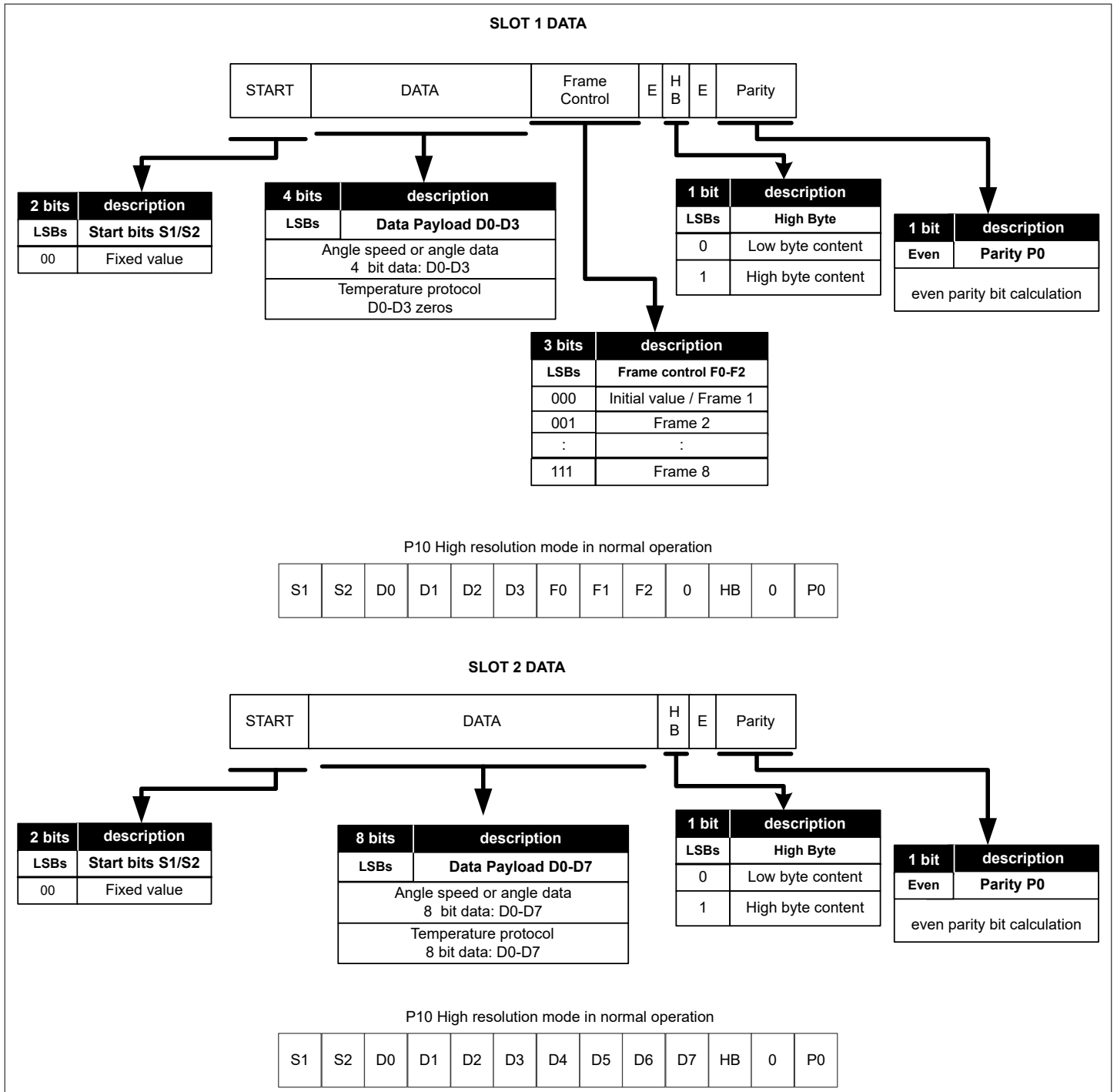

Figure 16 P10 High resolution normal operation mode

Due to the limited protocol bits, this protocol only has 1 variant available for the normal operation.

P10 high resolution data mode	Data [LSB]	Bitfield bits	Slot 1				Slot 2							Angle resolution	
			D0	D2	D1	D0	D0	D1	D2	D3	D4	D5	D6		D7
10 bit	Angle value	15:4	12	13	14	15	4	5	6	7	8	9	10	11	0.094°/LSB

Figure 17 P10 high resolution angle protocol data

Note: The angle value is scaled to fit the value range of [-1920, 1920] according to the PSI5 standard.

The angle speed protocol depends on the selected angle speed transmission mode.

P10 high resolution angle mode	Data [LSB]	Bitfield bits	Slot 1				Slot 2							Angle speed resolution	
			D0	D1	D2	D3	D0	D1	D2	D3	D4	D5	D6		D7
vα1 (±1000°/s)	Angle speed value	11:0	8	9	10	11	0	1	2	3	4	5	6	7	0.521°/s/LSB
vα2 (±5000°/s)	Angle speed value	11:0	8	9	10	11	0	1	2	3	4	5	6	7	2.604°/s/LSB
vα3 (±4606°/s)	Angle speed value	15:4	12	13	14	15	4	5	6	7	8	9	10	11	2.399°/s/LSB
vα4 (±180000°/s)	Angle speed value	15:4	12	13	14	15	4	5	6	7	8	9	10	11	93.75°/s/LSB

Figure 18 P10 high resolution angle speed protocol

The temperature protocol transmits the complete 8 bits from the internal temperature.

P10 high resolution temperature	Data [LSB]	Bitfield bits	Slot 2							Temperature resolution	
			D0	D1	D2	D3	D4	D5	D6		D7
10 bit	Temp.	7:0	0	1	2	3	4	5	6	7	1C°/LSB

Figure 19 P10 high resolution temperature protocol

P10 high resolution error mode

The error message in P10 High resolution mode is defined, like described in [P10 high resolution mode initialization phase III data content](#)

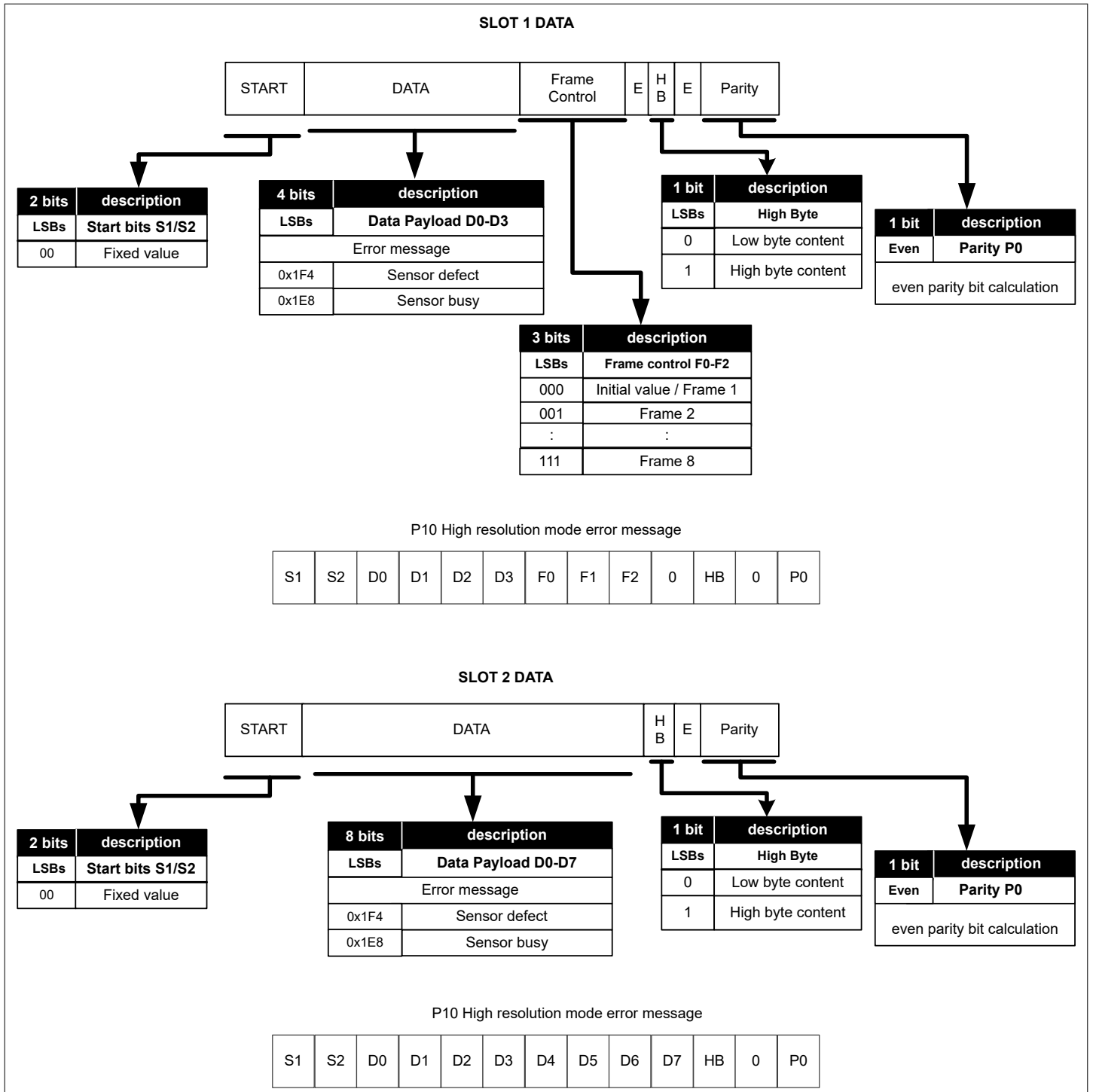

Figure 20 P10 High resolution error mode

5.2.1.6.4 P16CRC mode

The initialization phase II of each PSI5 mode is different. Additionally, each frame can be repeated up to 4 times, which is defined in the repetition factor k. The initialization phase II of P16CRC mode is shown in the following figure.

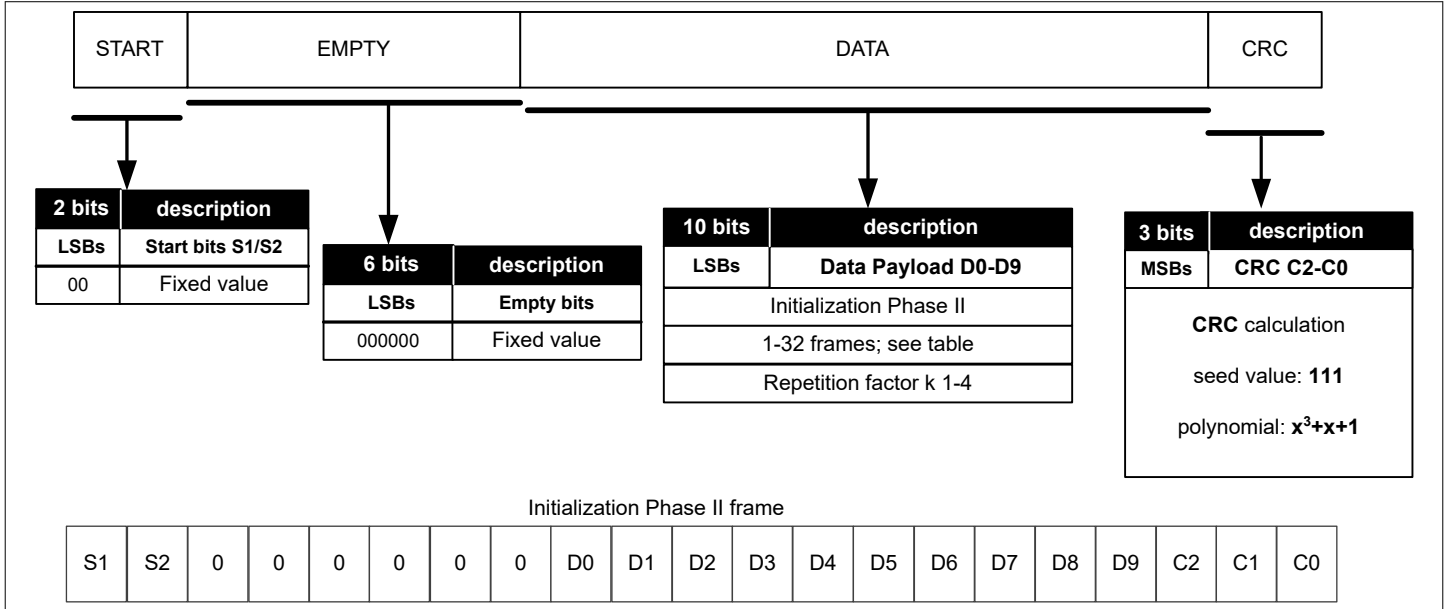

Figure 21 P16CRC mode initialization phase II

P16CRC mode initialization phase II data content

The frame 0-31 of the initialization phase II are the same as defined in the initialization phase II of the [P10P mode initialization phase II data content](#), but shifted up by 6 bits.

P16CRC mode initialization phase III data content

The bits D6 to D15 will contain the sensor status which can have one of the following three values depending on the error flag status:

Table 25 Frames of the initialization phase III

Sensor Status	Data	D0	D1	D2	D3	D4	D5	D6	D7	D8	D9	D10	D11	D12	D13	D14	D15
SENSOR_BUSY	0x1E8	0	0	0	0	0	0	0	0	0	1	0	1	1	1	1	0
SENSOR_DEFECT	0x1F4	0	0	0	0	0	0	0	0	1	0	1	1	1	1	1	0
SENSOR_READY	0x1E7	1	1	1	1	1	1	1	1	1	0	0	1	1	1	1	0

P16CRC normal operation mode

The normal operation of P16CRC mode supports 8 different frame formats:

- 12, 14, 16 Bit angle data
- 12, 16 Bit angle speed data
- 16 Bit temperature

5 Specific module descriptions

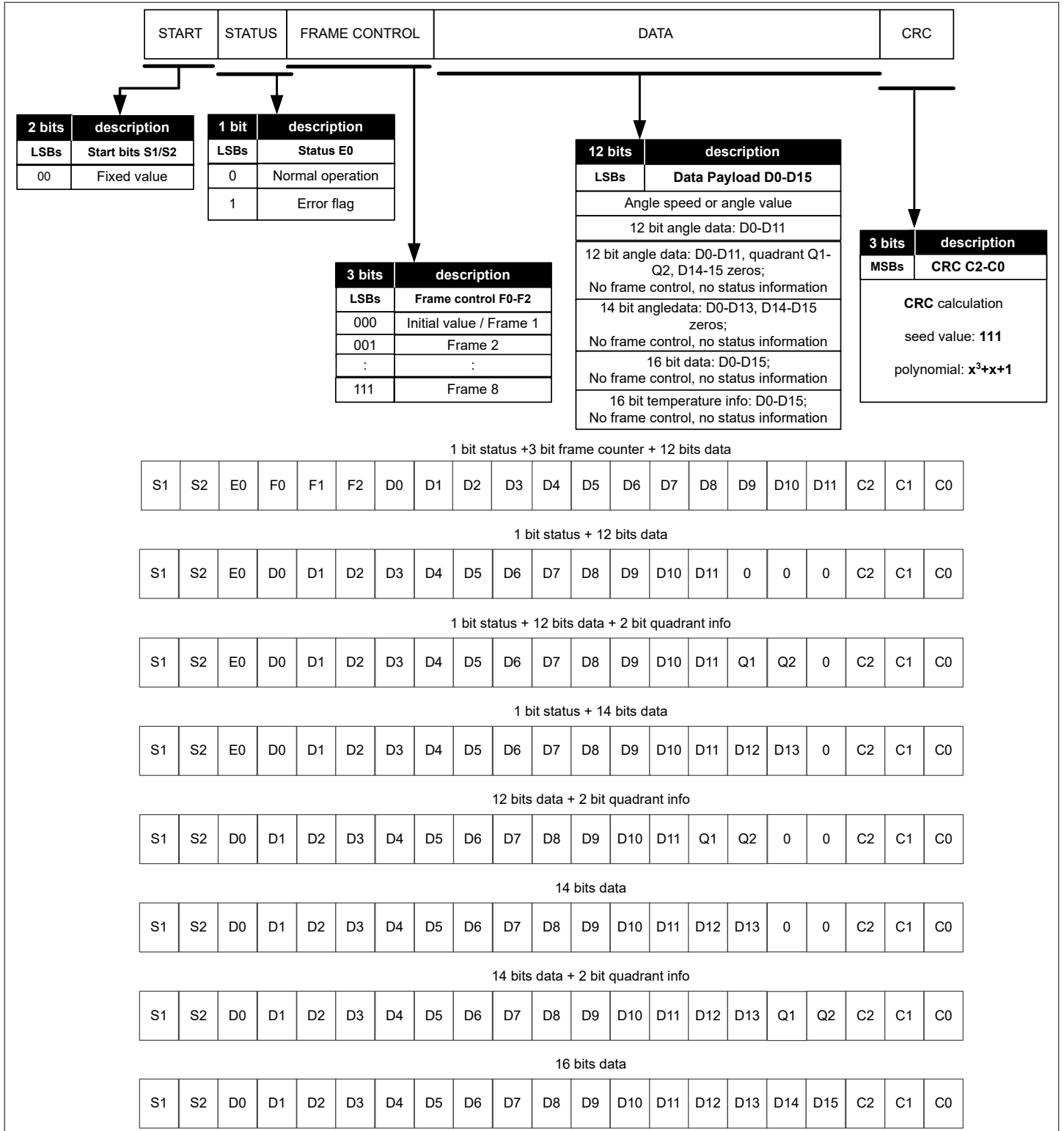

Figure 22 P16CRC mode in normal operation

P16CRC data mode	Data [LSB]	Bitfield bits	D0	D1	D2	D3	D4	D5	D6	D7	D8	D9	D10	D11	D12	D13	D14	D15	Angle resolution
0	Status	-	E0	-	-	-	-	-	-	-	-	-	-	-	-	-	-	-	0.022°/LSB
	Frame counter	2:0	-	F0	F1	F2	-	-	-	-	-	-	-	-	-	-	-	-	
	Angle value	13:2	-	-	-	-	2	3	4	5	6	7	8	9	10	11	12	13	
1	Status	-	E0	-	-	-	-	-	-	-	-	-	-	-	-	-	-	-	0.022°/LSB
	Angle value	13:2	-	2	3	4	5	6	7	8	9	10	11	12	13	-	-	-	
2	Status	-	E0	-	-	-	-	-	-	-	-	-	-	-	-	-	-	-	0.022°/LSB
	Angle value	13:2	-	2	3	4	5	6	7	8	9	10	11	12	13	-	-	-	
	Quadrant info	1:0	-	-	-	-	-	-	-	-	-	-	-	-	-	0	1	-	
3	Status	-	E0	-	-	-	-	-	-	-	-	-	-	-	-	-	-	-	0.005°/LSB
	Angle value	13:0	-	0	1	2	3	4	5	6	7	8	9	10	11	12	13	-	
4	Angle value	13:0	2	3	4	5	6	7	8	9	10	11	12	13	-	-	-	-	0.023°/LSB
	Quadrant info	1:0	-	-	-	-	-	-	-	-	-	-	-	-	0	1	-	-	
5	Angle value	13:0	0	1	2	3	4	5	6	7	8	9	10	11	12	13	-	-	0.006°/LSB
6	Angle value	13:0	0	1	2	3	4	5	6	7	8	9	10	11	12	13	-	-	0.006°/LSB
	Quadrant info	1:0	-	-	-	-	-	-	-	-	-	-	-	-	-	-	0	1	
7	Angle value	13:0	0	1	2	3	4	5	6	7	8	9	10	11	12	13	-	-	0.006°/LSB

Figure 23 Characteristic curve 90°

P16CRC data mode	Data [LSB]	Bitfield bits	D0	D1	D2	D3	D4	D5	D6	D7	D8	D9	D10	D11	D12	D13	D14	D15	Angle resolution
0	Status	-	E0	-	-	-	-	-	-	-	-	-	-	-	-	-	-	-	0.029°/LSB
	Frame counter	2:0	-	F0	F1	F2	-	-	-	-	-	-	-	-	-	-	-	-	
	Angle value	13:2	-	-	-	-	2	3	4	5	6	7	8	9	10	11	12	13	
1	Status	-	E0	-	-	-	-	-	-	-	-	-	-	-	-	-	-	-	0.029°/LSB
	Angle value	13:2	-	2	3	4	5	6	7	8	9	10	11	12	13	-	-	-	
2	Status	-	E0	-	-	-	-	-	-	-	-	-	-	-	-	-	-	-	0.029°/LSB
	Angle value	13:2	-	2	3	4	5	6	7	8	9	10	11	12	13	-	-	-	
	Quadrant info	1:0	-	-	-	-	-	-	-	-	-	-	-	-	-	0	1	-	
3	Status	-	E0	-	-	-	-	-	-	-	-	-	-	-	-	-	-	-	0.007°/LSB
	Angle value	13:0	-	0	1	2	3	4	5	6	7	8	9	10	11	12	13	-	
4	Angle value	13:0	2	3	4	5	6	7	8	9	10	11	12	13	-	-	-	-	0.031°/LSB
	Quadrant info	1:0	-	-	-	-	-	-	-	-	-	-	-	-	0	1	-	-	
5	Angle value	13:0	0	1	2	3	4	5	6	7	8	9	10	11	12	13	-	-	0.008°/LSB
6	Angle value	13:0	0	1	2	3	4	5	6	7	8	9	10	11	12	13	-	-	0.008°/LSB
	Quadrant info	1:0	-	-	-	-	-	-	-	-	-	-	-	-	-	-	0	1	
7	Angle value	13:0	0	1	2	3	4	5	6	7	8	9	10	11	12	13	-	-	0.008°/LSB

Figure 24 Characteristic curve 120°

P16CRC data mode	Data [LSB]	Bitfield bits	D0	D1	D2	D3	D4	D5	D6	D7	D8	D9	D10	D11	D12	D13	D14	D15	Angle resolution
0	Status	-	E0	-	-	-	-	-	-	-	-	-	-	-	-	-	-	-	0.088°/LSB
	Frame counter	2:0	-	F0	F1	F2	-	-	-	-	-	-	-	-	-	-	-	-	
	Angle value	15:4	-	-	-	-	4	5	6	7	8	9	10	11	12	13	14	15	
1	Status	-	E0	-	-	-	-	-	-	-	-	-	-	-	-	-	-	-	0.088°/LSB
	Angle value	15:4	-	4	5	6	7	8	9	10	11	12	13	14	15	-	-	-	
2	Status	-	E0	-	-	-	-	-	-	-	-	-	-	-	-	-	-	-	0.088°/LSB
	Angle value	15:4	-	4	5	6	7	8	9	10	11	12	13	14	15	-	-	-	
3	Status	-	E0	-	-	-	-	-	-	-	-	-	-	-	-	-	-	-	0.022°/LSB
	Angle value	15:2	-	2	3	4	5	6	7	8	9	10	11	12	13	14	15	-	
4	Angle value	15:4	4	5	6	7	8	9	10	11	12	13	14	15	-	-	-	-	0.094°/LSB
5	Angle value	15:2	2	3	4	5	6	7	8	9	10	11	12	13	14	15	-	-	0.023°/LSB
6	Angle value	15:2	2	3	4	5	6	7	8	9	10	11	12	13	14	15	-	-	0.023°/LSB
7	Angle value	15:0	0	1	2	3	4	5	6	7	8	9	10	11	12	13	14	15	0.006°/LSB

Figure 25 Characteristic curve 360°

The angle speed protocol depends on the selected angle speed transmission mode.

P16CRC Angle speed mode	Data [LSB]	Bitfields bits	D0	D1	D2	D3	D4	D5	D6	D7	D8	D9	D10	D11	D12	D13	D14	D15	Angle speed resolution
va1 (+1000°/s)	Status	-	E0	-	-	-	-	-	-	-	-	-	-	-	-	-	-	-	0.488°/s/LSB
	Frame counter	2:0	-	F0	F1	F2	-	-	-	-	-	-	-	-	-	-	-	-	
	Angle speed value	11:0	-	-	-	-	0	1	2	3	4	5	6	7	8	9	10	11	
va2 (+5000°/s)	Status	-	E0	-	-	-	-	-	-	-	-	-	-	-	-	-	-	-	2.441°/s/LSB
	Frame counter	2:0	-	F0	F1	F2	-	-	-	-	-	-	-	-	-	-	-	-	
	Angle speed value	11:0	-	-	-	-	0	1	2	3	4	5	6	7	8	9	10	11	
va3 (+4606°/s)	Angle speed value	15:0	0	1	2	3	4	5	6	7	8	9	10	11	12	13	14	15	0.150°/s/LSB
va4 (+180000°/s)	Angle speed value	15:0	0	1	2	3	4	5	6	7	8	9	10	11	12	13	14	15	5.859°/s/LSB

Figure 26 P16CRC Angle speed protocol data

The temperature protocol transmits the complete 16 bits from the internal temperature

P16CRC temperature	Data [LSB]	Bitfield bits	D0	D1	D2	D3	D4	D5	D6	D7	D8	D9	D10	D11	D12	D13	D14	D15	Temperature resolution
16 bit	Temperature	15:0	0	1	2	3	4	5	6	7	8	9	10	11	12	13	14	15	0.033°C/LSB

Figure 27 P16CRC Temperature data

P16CRC error mode

The error message in P16CRC mode is defined with:

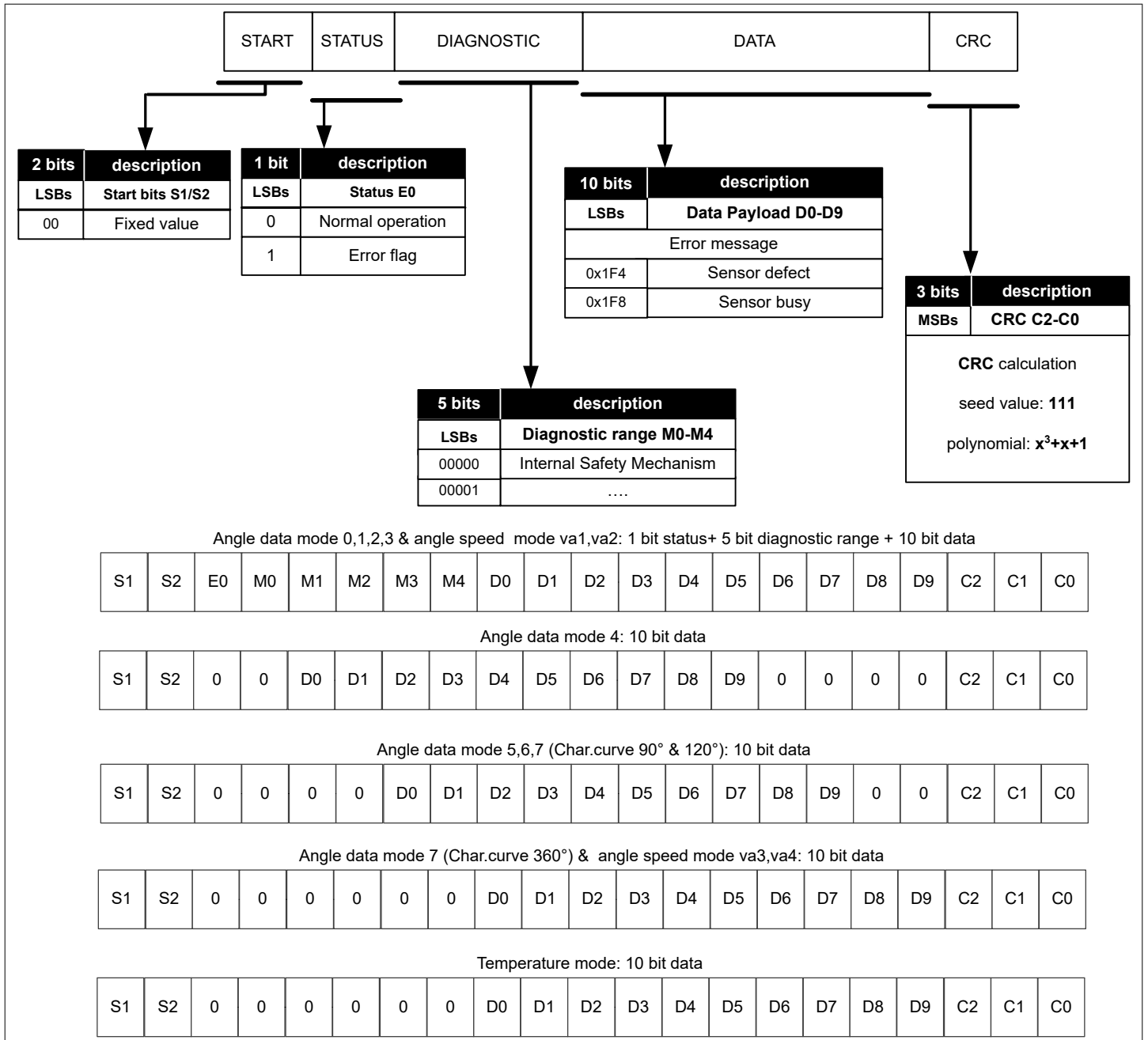

Figure 28 **P16CRC mode error message**

Note: For more information about the diagnostic range codes please consult the TLE49SR user manual.

5.2.1.6.5 P20CRC mode

The initialization phase II of each PSI5 mode is different. Additionally, each frame can be repeated up to 4 times, which is defined in the repetition factor k. The initialization phase II of P20CRC mode is shown in the following figure.

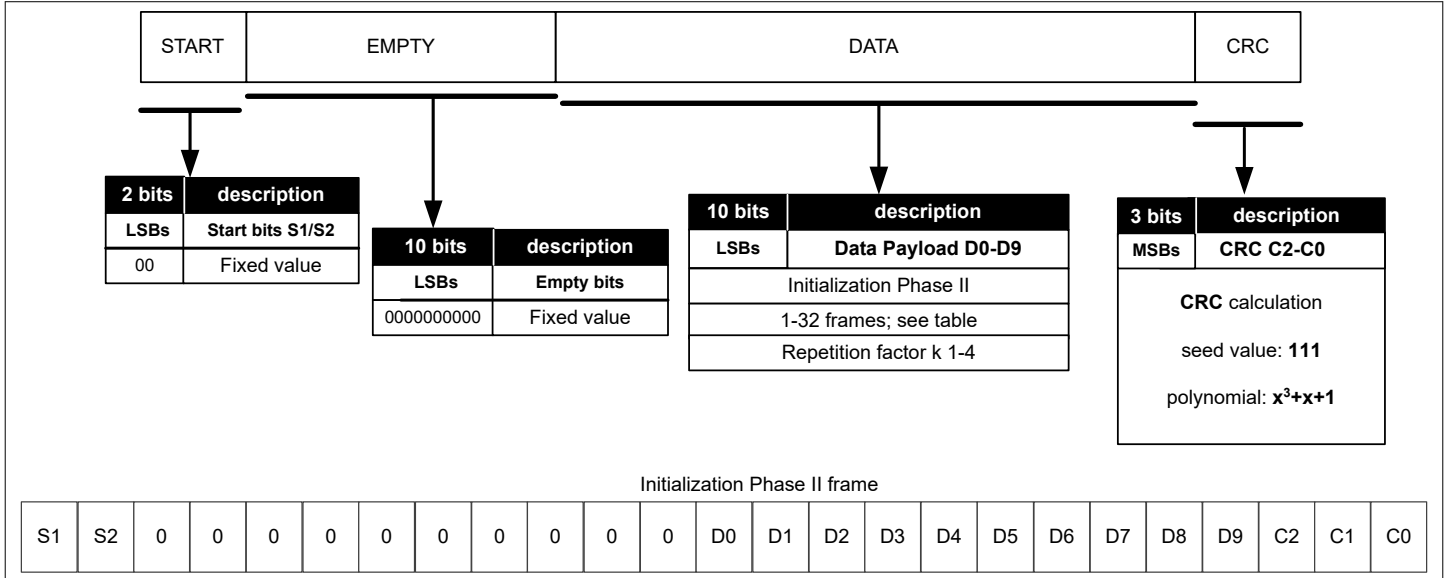

Figure 29 P20CRC mode initialization phase II

P20CRC mode initialization phase II data content

The frame 0-31 of the initialization phase II are the same as defined in the initialization phase II of the [P10P mode initialization phase II data content](#)

P20CRC mode initialization phase III data content

The frames of the initialization phase III are the same as defined in the initialization phase III of the [P16CRC mode initialization phase III data content](#).

P20CRC normal operation mode

The normal operation of P20CRC mode supports 5 different frame formats:

- 12, 14, 16 Bit angle data
- 12, 16 Bit angle speed data
- 16 Bit temperature

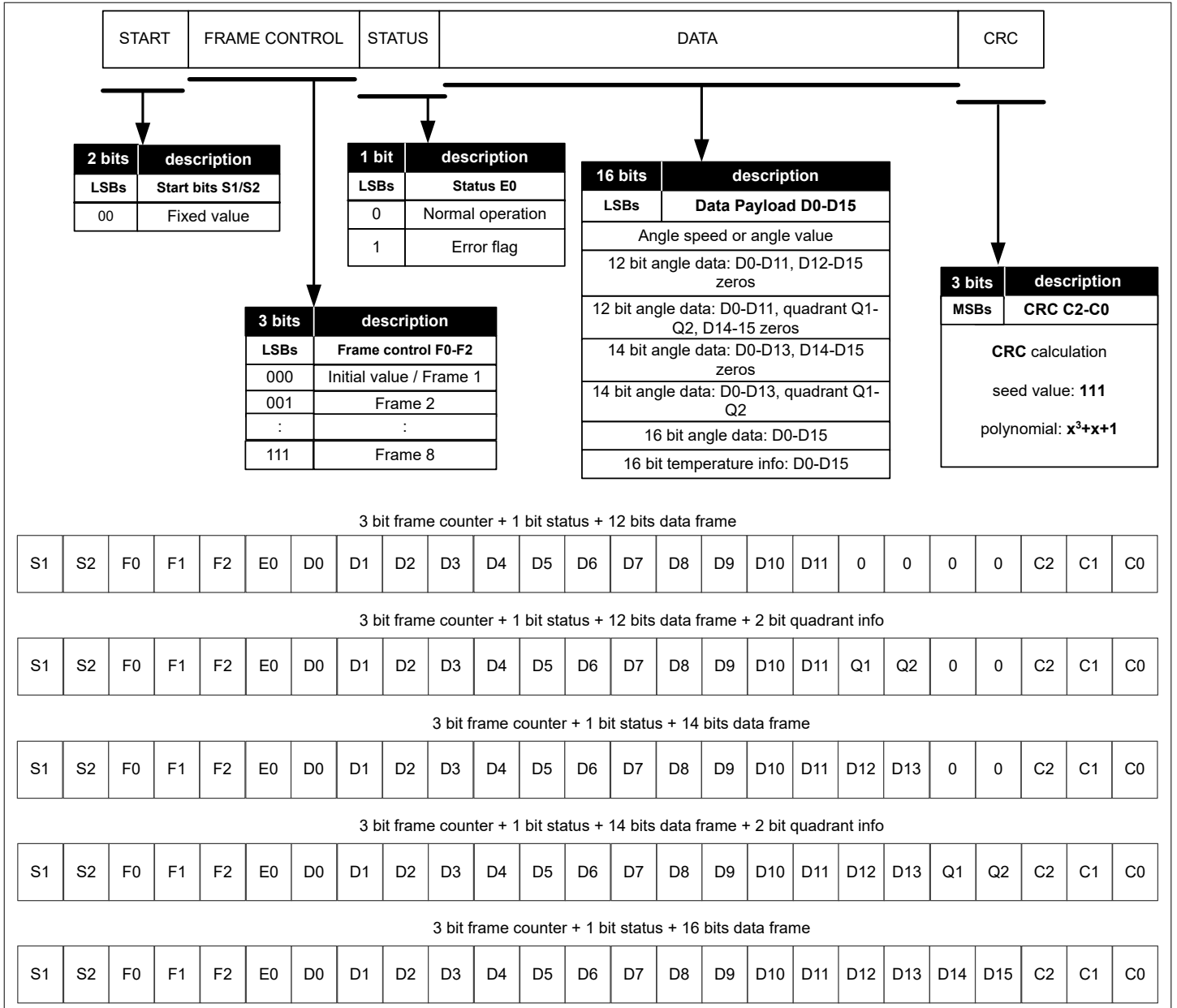

Figure 30 P20CRC normal operation mode

The angle speed protocol depends on the selected angle speed transmission mode.

P20CRC angle speed	Data [LSB]	Bitfield bits	Frame counter	Frame counter	Frame counter	Status	D0	D1	D2	D3	D4	D5	D6	D7	D8	D9	D10	D11	D12	D13	D14	D15	Angle speed resolution
$\alpha_1 (+1000^\circ/s)$	Angle speed value	11:0	F0	F1	F2	E0	0	1	2	3	4	5	6	7	8	9	10	11	-	-	-	-	0.488°/s/LSB
$\alpha_2 (+5000^\circ/s)$	Angle speed value	11:0	F0	F1	F2	E0	0	1	2	3	4	5	6	7	8	9	10	11	-	-	-	-	2.442°/s/LSB
$\alpha_3 (+4606^\circ/s)$	Angle speed value	15:0	F0	F1	F2	E0	0	1	2	3	4	5	6	7	8	9	10	11	12	13	14	15	0.141°/s/LSB
$\alpha_4 (+180000^\circ/s)$	Angle speed value	15:0	F0	F1	F2	E0	0	1	2	3	4	5	6	7	8	9	10	11	12	13	14	15	5.493°/s/LSB

Figure 31 P20CRC angle speed protocol data

The temperature protocol transmits the complete 16 bit from the internal temperature.

P20CRC temperature data	Data [LSB]	Bitfield bits	Frame counter	Frame counter	Frame counter	Status	D0	D1	D2	D3	D4	D5	D6	D7	D8	D9	D10	D11	D12	D13	D14	D15	Temperature resolution
16 bit	Temperature	15:0	F0	F1	F2	E0	0	1	2	3	4	5	6	7	8	9	10	11	12	13	14	15	0.031°/LSB

Figure 32 P20CRC Temperature data

P20CRC error mode

The error message in P20CRC mode is defined with:

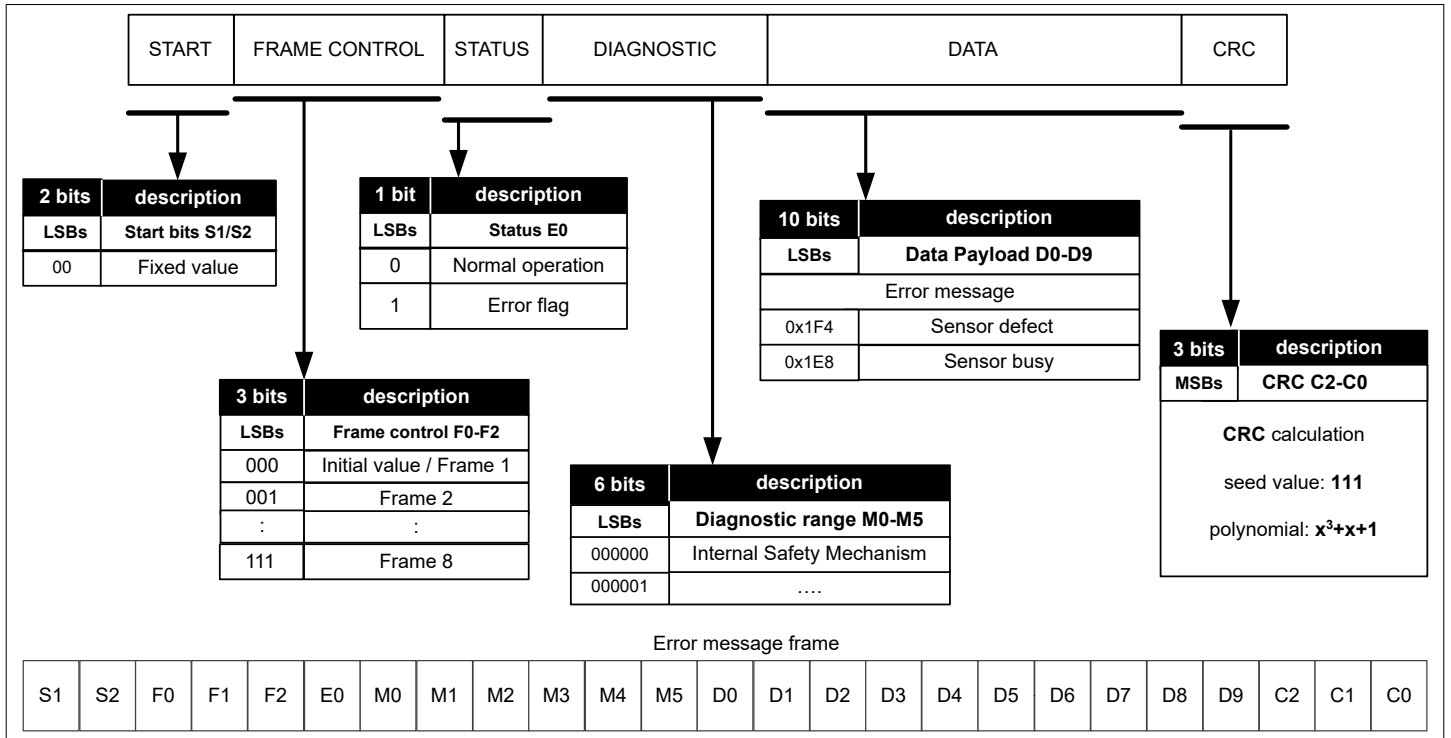

Figure 33 P20CRC error mode

Note: For more information about the diagnostic range codes please consult the TLE49SR user manual.

P20CRC data mode	Data [LSB]	Bitfield bits	D0	D1	D2	D3	D4	D5	D6	D7	D8	D9	Angle resolution
0	Angle value	13:4	4	5	6	7	8	9	10	11	12	13	0.088°/LSB
1	Angle value	13:6	6	7	8	9	10	11	12	13	-	-	0.352°/LSB
	Quadrant info	1:0	-	-	-	-	-	-	-	0	1		
2	Angle value	13:4	4	5	6	7	8	9	10	11	12	13	0.088°/LSB
3	Angle value	13:6	6	7	8	9	10	11	12	13	-	-	0.352°/LSB
	Quadrant info	1:0	-	-	-	-	-	-	-	0	1		
4	Angle value	13:4	4	5	6	7	8	9	10	11	12	13	0.088°/LSB

Figure 34 Characteristic curve 90°

P20CRC data mode	Data [LSB]	Bitfield bits	D0	D1	D2	D3	D4	D5	D6	D7	D8	D9	Angle resolution
0	Angle value	13:4	4	5	6	7	8	9	10	11	12	13	0.117°/LSB
1	Angle value	13:6	6	7	8	9	10	11	12	13	-	-	0.469°/LSB
	Quadrant info	1:0	-	-	-	-	-	-	-	-	0	1	
2	Angle value	13:4	4	5	6	7	8	9	10	11	12	13	0.117°/LSB
3	Angle value	13:6	6	7	8	9	10	11	12	13	-	-	0.469°/LSB
	Quadrant info	1:0	-	-	-	-	-	-	-	-	0	1	
4	Angle value	13:4	4	5	6	7	8	9	10	11	12	13	0.117°/LSB

Figure 35 Characteristic curve 120°

P20CRC data mode	Data [LSB]	Bitfield bits	D0	D1	D2	D3	D4	D5	D6	D7	D8	D9	Angle resolution
0, 1, 2, 3, 4	Angle value	15:6	6	7	8	9	10	11	12	13	14	15	0.352°/LSB

Figure 36 Characteristic curve 360°

P20CRC angle speed mode	Data [LSB]	Bitfield bits	D0	D1	D2	D3	D4	D5	D6	D7	D8	D9	Angle speed resolution
vα1 (+-1000°/s)	Angle speed value	11:2	2	3	4	5	6	7	8	9	10	11	1.953°/s/LSB
vα2 (+-5000°/s)	Angle speed value	11:2	2	3	4	5	6	7	8	9	10	11	9.766°/s/LSB
vα3 (+-4606°/s)	Angle speed value	15:6	6	7	8	9	10	11	12	13	14	15	8.996°/s/LSB
vα4 (+-180000°/s)	Angle speed value	15:6	6	7	8	9	10	11	12	13	14	15	351.6°/s/LSB

Figure 37 P20CRC error mode angle speed protocol data

P20CRC temperature	Data [LSB]	Bitfield bits	D0	D1	D2	D3	D4	D5	D6	D7	D8	D9	Temperature resolution
16 bit	Temperature	15:6	6	7	8	9	10	11	12	13	14	15	2°C/LSB

Figure 38 P20CRC error mode temperature data

5.2.2 SICI programming interface

A single wire interface (SICI) which is on the same output pin as the PSI5 output, is implemented. This interface is used to perform the EEPROM programming with application and customer specific data (angle base, look-up table, customer-ID). In addition, some chip configuration can be done. More details can be found in the corresponding user manual.

5.3 Programming characteristics

Sensor ID

The sensor has an electrically stored ID which allows unique tracking after production.

Customer ID

Customer specific data, e.g. customer module ID, can be written in the EEPROM via SICI interface.

5.3.1 Calibration and Look-Up-Table (LUT)

The sensor allows configuration of 32 equidistant calibration points or 16 freely programmable calibration points, as shown at the below figures:

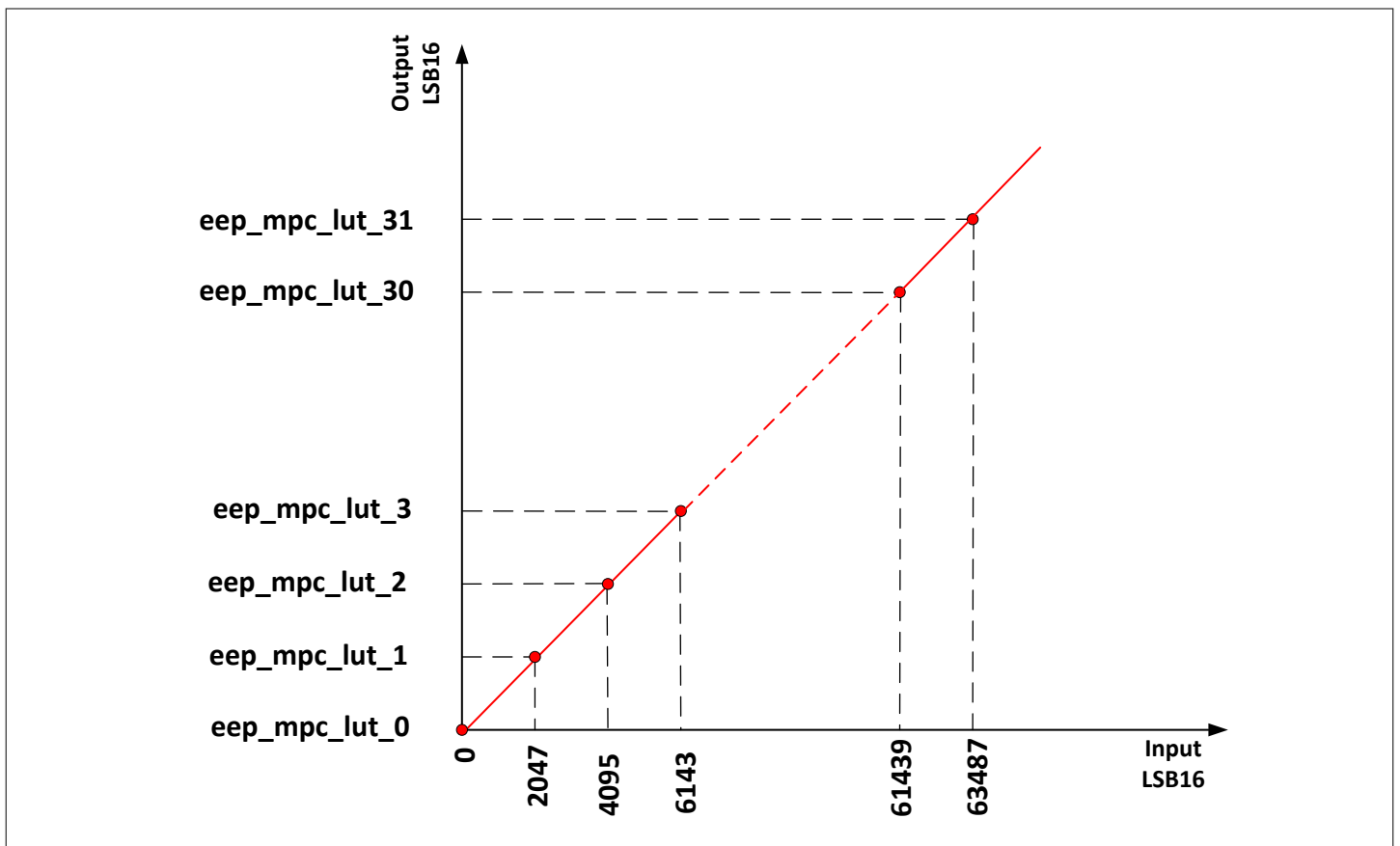

Figure 39 32 equidistant calibration points

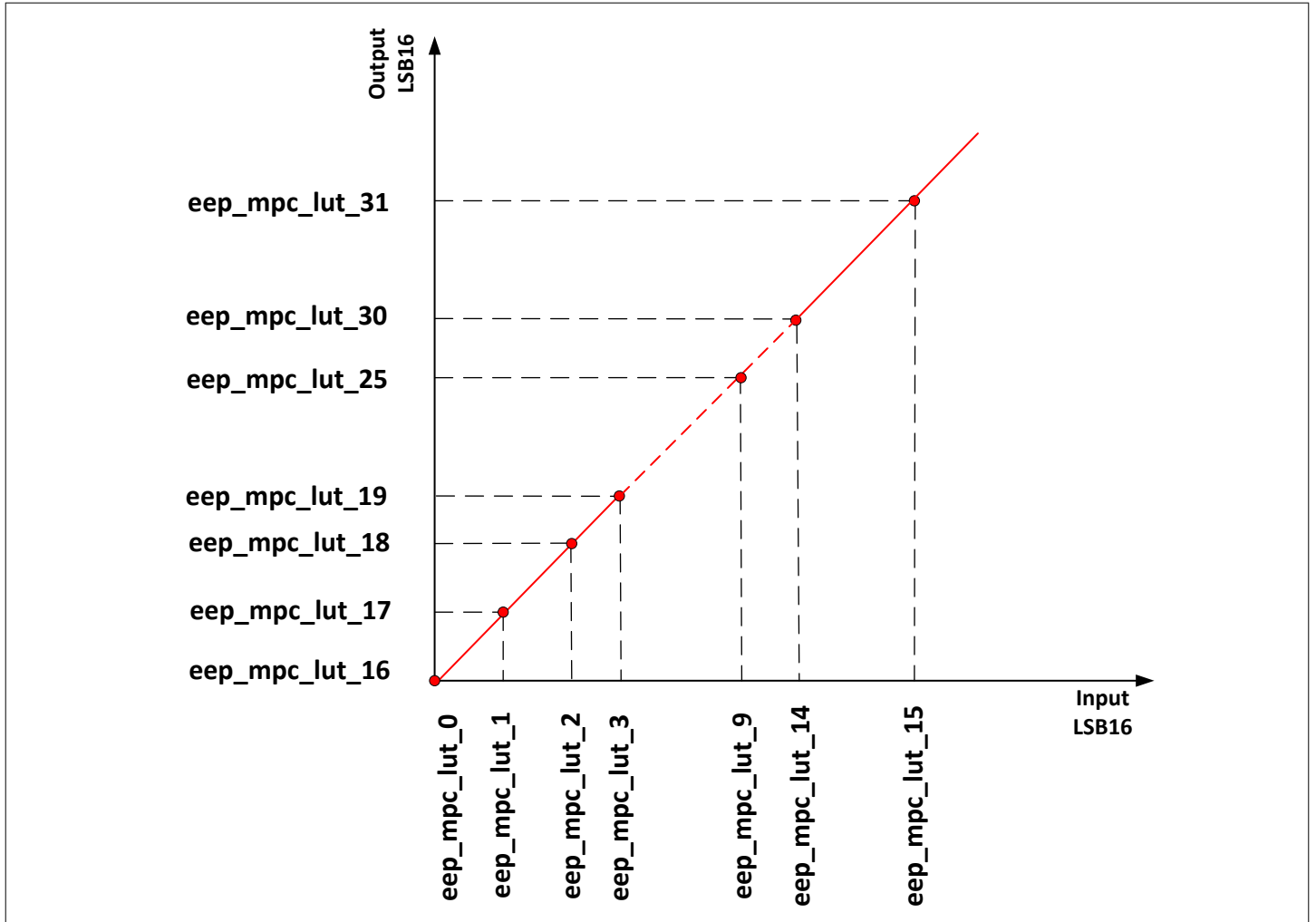

Figure 40 16 freely programmable points

5.3.2 Programmable measurement range

Free selective measuring range

The measuring range (start / stop) is freely selective with a resolution of 16 bit. The resolution of 16 bit refers to 360°.

The characteristic curve of the sensor can be divided up to 4 predefined segments. Typically, the 360° angular range is divided into 4 x 90°, 3 x 120° or 1 x 360° segments.

Additionally, it is possible to define a measurement range inside the full 360° range. For example, a 70° measurement range can be defined from 40° to 110°.

It is also possible to clamp the angle limits, this can be freely configured by the customer, plus the calibration points can be used to linearize the characteristic curves.

Please note that the calibration points are always for 360°, so at least 1 or 2 points have to be sacrificed to complete the 360° if the angle range is clamped.

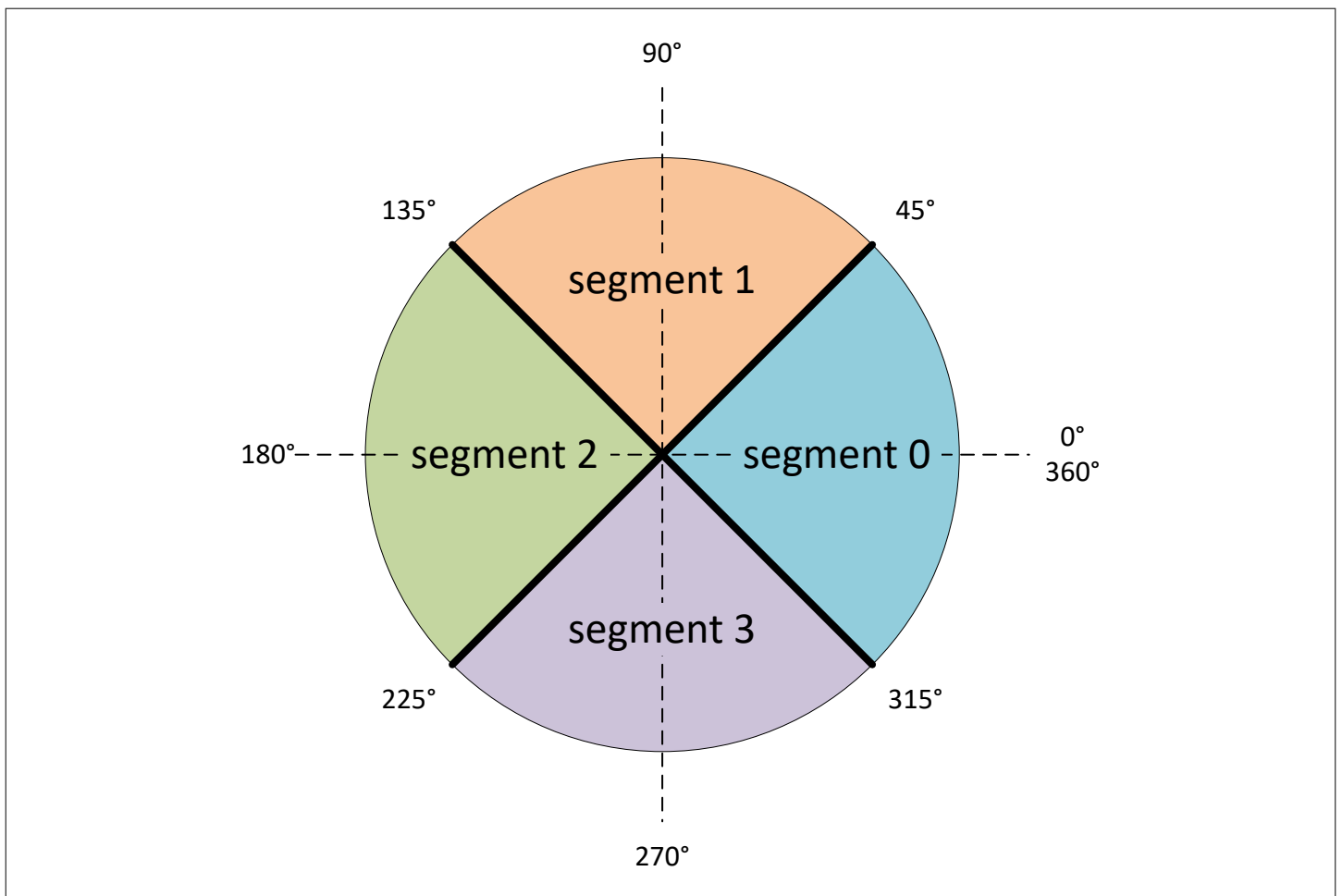

Figure 41 Programmable output 90° characteristic curve

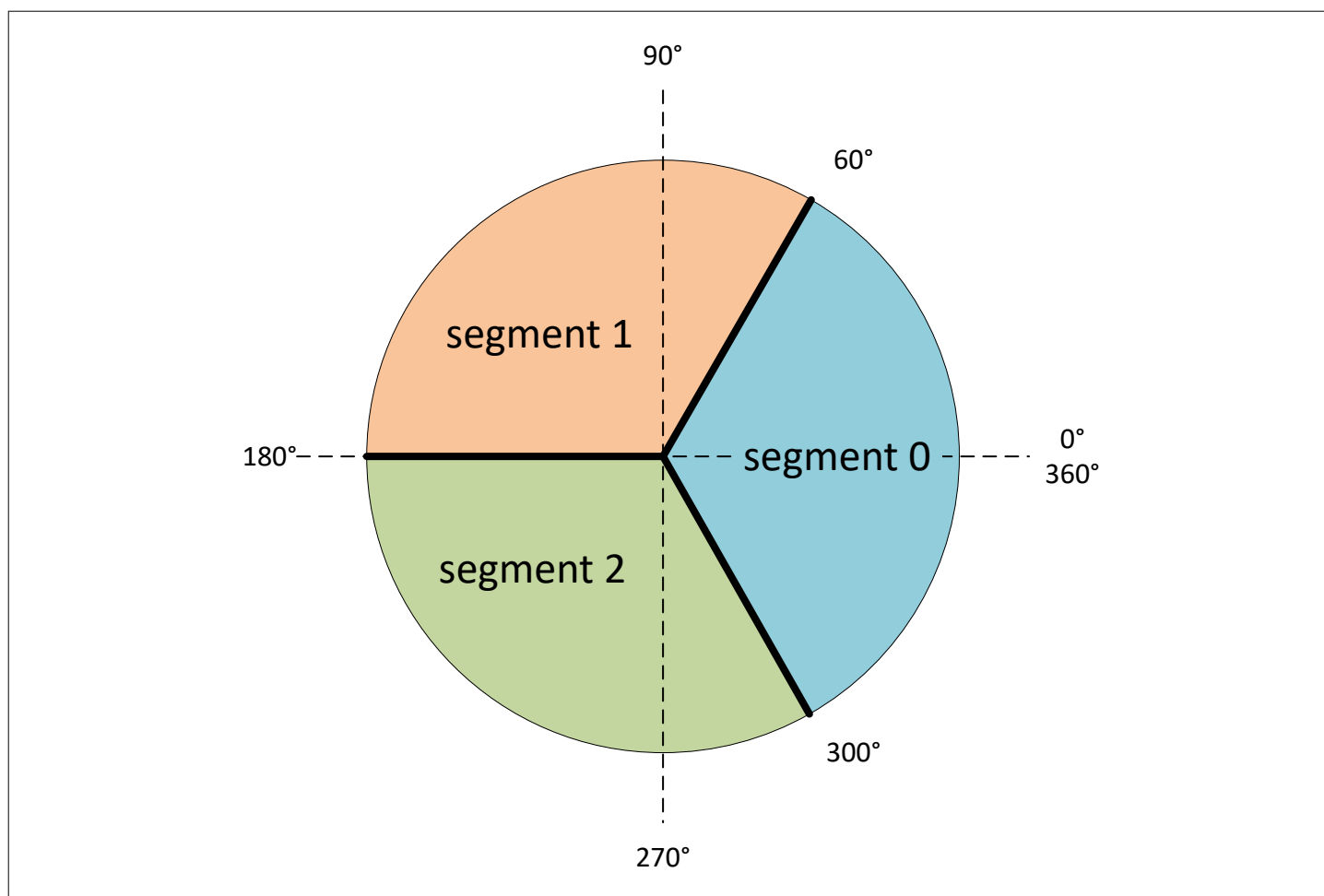

Figure 42 Programmable output 120° characteristic curve

5.3.3 EEPROM

The sensor includes a non-volatile memory (NVM) where calibration data and sensor configuration data are stored. The customer has access to a part of this memory for storage of application specific data (e.g. look-up table & customer ID)

Table 26 EEPROM parameters

Parameter	Symbol	Values			Unit	Note or condition
		Min.	Typ.	Max.		
Number of possible NVM programming cycles	n_{Prog}	-	-	100	-	-
Time for programming of whole NVM (customer relevant part)	t_{Prog}	-	0.5	-	s	incl. look-up table, configuration, customer ID
Programming temperature	$T_{\text{prog_temp}}$	10	-	60	°C	

6 Application Information

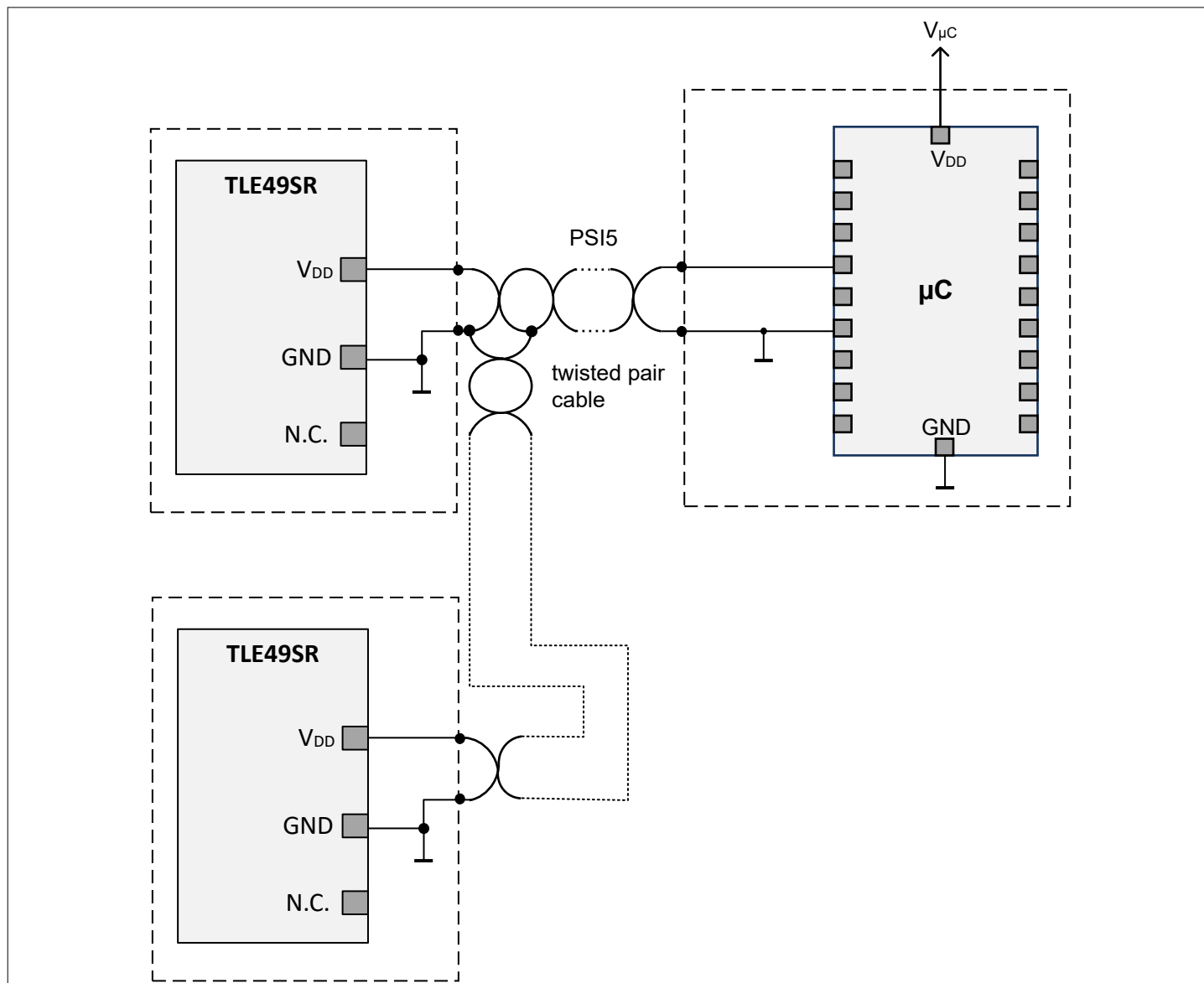

Figure 43 Application Circuit for PSI5 interface

7 Package information

The device is is halogen free, lead free and RoHS compliant.

Table 27 Position tolerances die to package

Parameter	Symbol	Values			Unit	Note / Test condition
		Min.	Typ.	Max.		
Tilt	-	-	-	2	°	in respect to the z-axis and reference plane
Rotational displacement	-	-	-	3	°	in respect to the reference axis
Placement tolerance in package	-	-	-	100	µm	in x and y direction

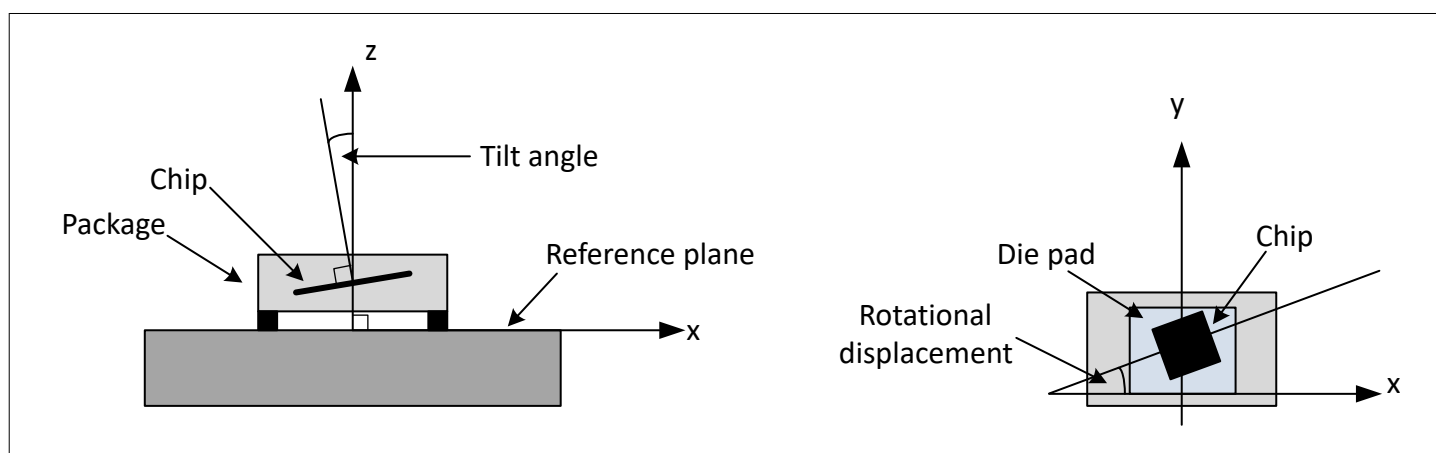

Figure 44 Tolerance of the die in the package

The package type is PG-SSO-3-41

TLE49SRI3
Stray field robust angle sensor with PSI5 interface

7 Package information

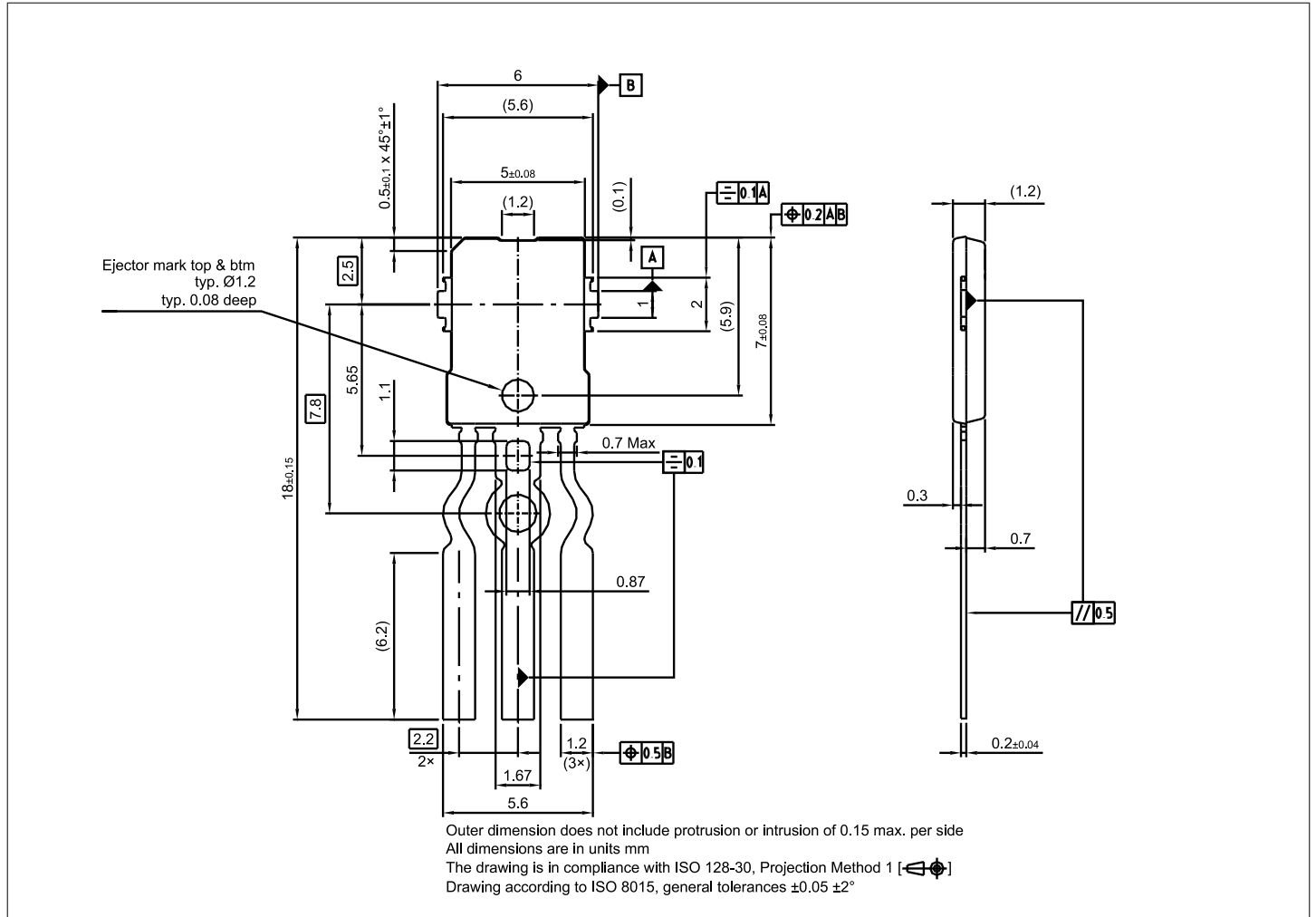

Figure 45 PG-SSO-3-41 package drawing

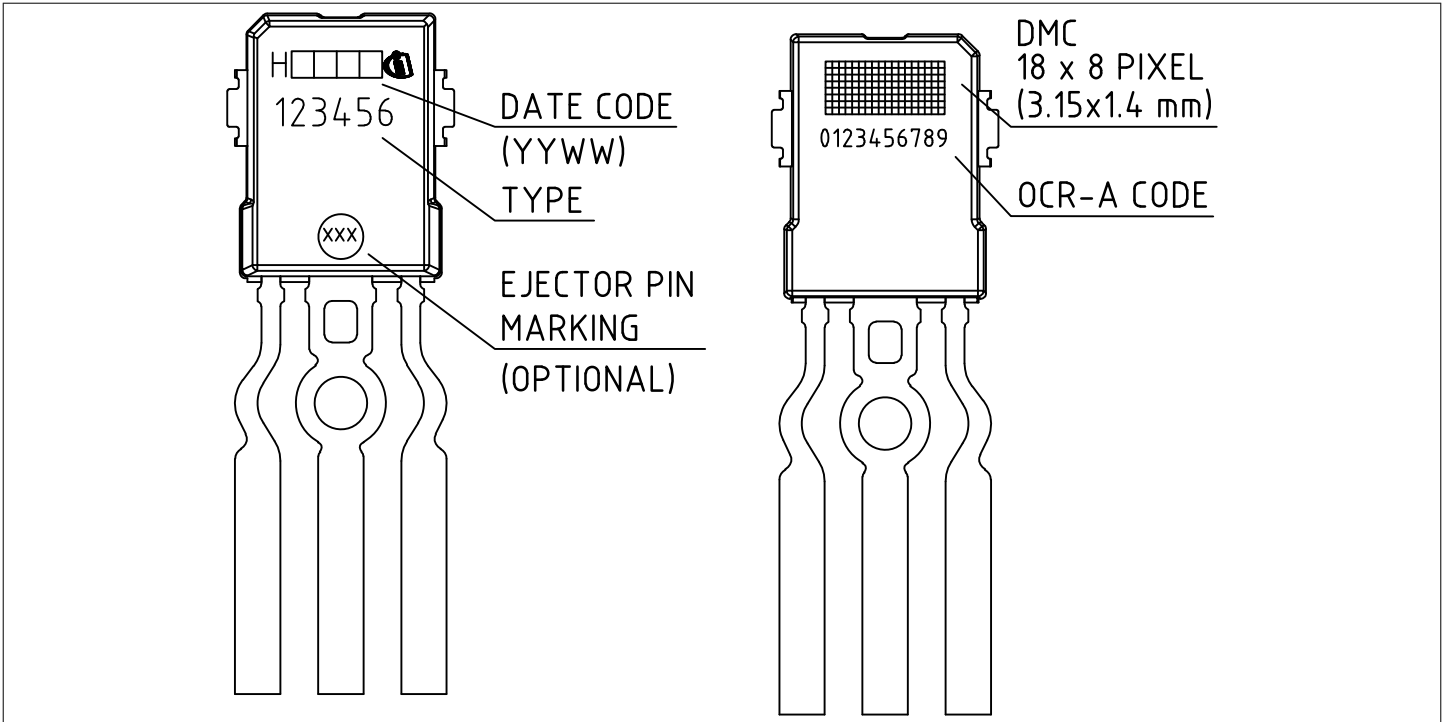

Figure 46 PG-SSO-3-41 Marking specification

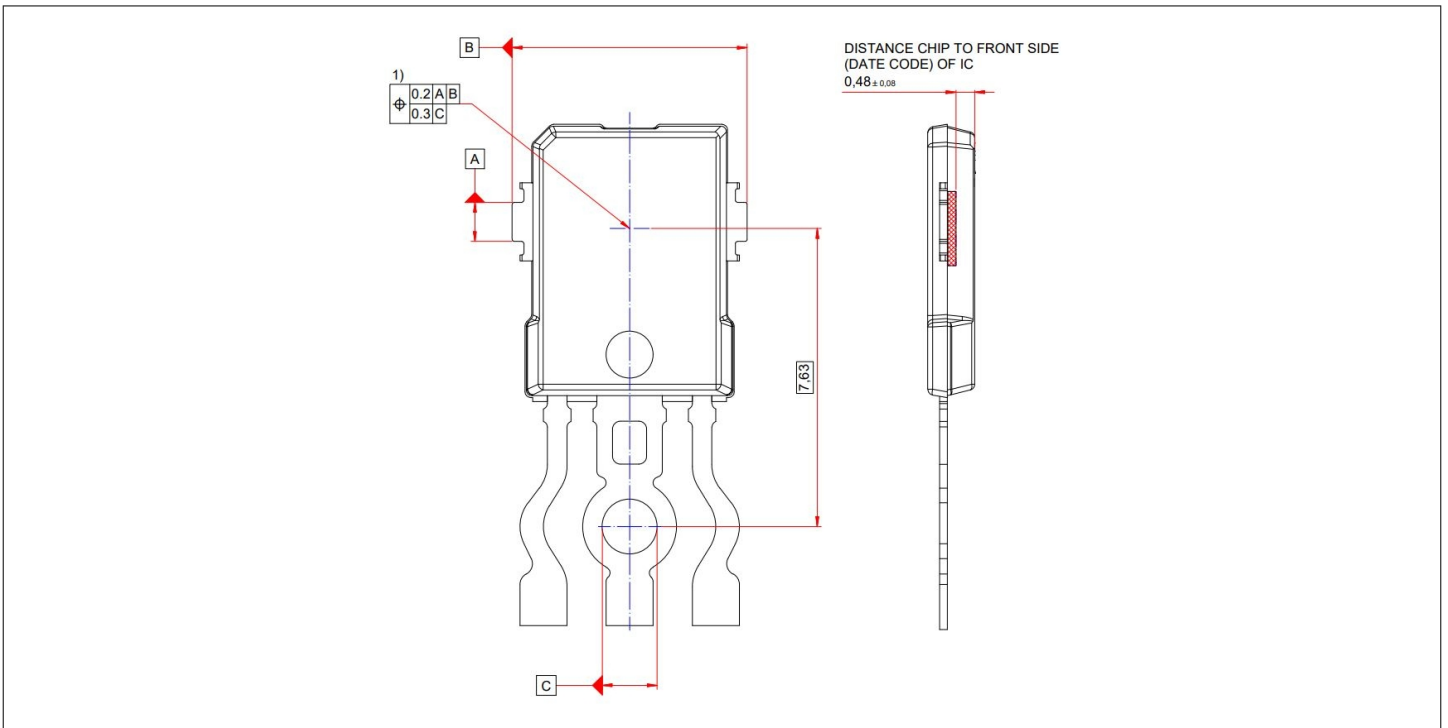

Figure 47 PG-SSO-3-41 Center of sensitive area

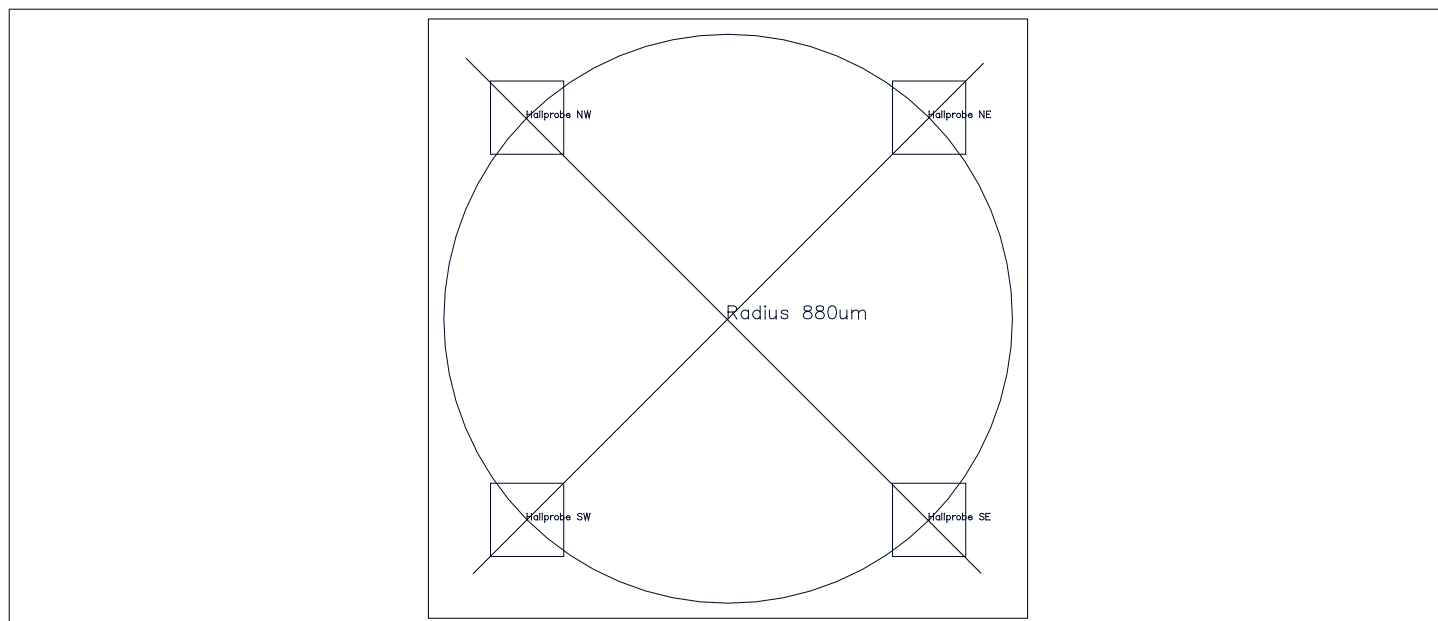

Figure 48 TLE49SR Hall element radius

8 Revision history

Revision	Date	Change description
Rev. 1.00	2024-03-13	Initial release

Trademarks

All referenced product or service names and trademarks are the property of their respective owners.

Edition 2024-03-13

Published by

Infineon Technologies AG

81726 Munich, Germany

© 2024 Infineon Technologies AG

All Rights Reserved.

Do you have a question about any aspect of this document?

Email: erratum@infineon.com

Document reference

IFX-baw1564573858515

Important notice

The information given in this document shall in no event be regarded as a guarantee of conditions or characteristics ("Beschaffheitsgarantie").

With respect to any examples, hints or any typical values stated herein and/or any information regarding the application of the product, Infineon Technologies hereby disclaims any and all warranties and liabilities of any kind, including without limitation warranties of non-infringement of intellectual property rights of any third party.

In addition, any information given in this document is subject to customer's compliance with its obligations stated in this document and any applicable legal requirements, norms and standards concerning customer's products and any use of the product of Infineon Technologies in customer's applications.

The data contained in this document is exclusively intended for technically trained staff. It is the responsibility of customer's technical departments to evaluate the suitability of the product for the intended application and the completeness of the product information given in this document with respect to such application.

Warnings

Due to technical requirements products may contain dangerous substances. For information on the types in question please contact your nearest Infineon Technologies office.

Except as otherwise explicitly approved by Infineon Technologies in a written document signed by authorized representatives of Infineon Technologies, Infineon Technologies' products may not be used in any applications where a failure of the product or any consequences of the use thereof can reasonably be expected to result in personal injury.

Mouser Electronics

Authorized Distributor

Click to View Pricing, Inventory, Delivery & Lifecycle Information:

[Infineon:](#)

[TLE49SRI3XTMA1](#)