

DC Motor Control Shield with TLE94112ES for Arduino

Z8F80681112

About this document

Scope and purpose

This user guide describes the DC motor control shield for Arduino that is equipped with the TLE94112ES, a twelve-fold half-bridge driver with integrated power stages. This document provides detailed information on the board's content, layout, and guidance on how to use it. This document should be used in conjunction with the [TLE94112ES datasheet](#), which contains full technical details on the device specification and operation.

Intended audience

Engineers, hobbyists and students who want to add a powerful motor control to Arduino projects.

Related information

Table 1 Supplementary links and document references

| Reference | Description |
|---|--|
| TLE94112ES datasheet | Product page which contains reference information for the multiple half-bridge driver TLE94112ES |
| TLE941xy SPI | Application note for the SPI of the multiple half-bridge driver family TLE941xy |
| XMC1100 Boot Kit | Information page for the XMC1100 Boot Kit |
| Infineon shields for Arduino | Information page for Infineon shields for Arduino |
| DC motor shield with TLE94112ES | Information page for DC Motor Control Shield with TLE94112ES |
| Arduino Home Page | All information on Arduino |
| Arduino Uno Product Page | Arduino Uno R3 description |
| Arduino IDE Download | Download page for Arduino Integrated Development Environment |
| Sample code for TLE94112ES | Arduino Uno sample code for Motor Control Shield with TLE94112ES |

Table of contents

Table of contents

| | | |
|----------|--|----|
| | About this document | 1 |
| | Table of contents | 2 |
| 1 | Introduction | 3 |
| 1.1 | DC Motor Control Shield overview | 3 |
| 1.2 | Key features | 4 |
| 1.3 | Application diagram for bi-directional DC motor applications | 5 |
| 2 | DC Motor Control Shield description | 6 |
| 2.1 | Overview | 6 |
| 2.2 | Schematics | 7 |
| 2.3 | Layout | 7 |
| 2.4 | Bill of Material of the DC Motor Shield | 9 |
| 2.5 | CSN1 and CSN2 Selection | 9 |
| 2.6 | Stacking two DC Motor Shields | 11 |
| 2.7 | Pin assignment | 11 |
| 2.8 | Pin definitions and functions | 12 |
| 3 | TLE94112ES overview | 14 |
| 3.1 | Key features of the TLE94112ES | 14 |
| 3.2 | Block diagram | 15 |
| 3.3 | Pin assignment | 16 |
| 3.4 | Pin definitions and functions | 16 |
| 4 | Getting started | 18 |
| 4.1 | Target applications | 18 |
| 4.2 | Getting started: shield | 18 |
| 4.3 | Getting started: software | 21 |
| 4.4 | Sketch example for DC motor shield | 21 |
| | Glossary | 23 |
| | Revision history | 25 |
| | Disclaimer | 26 |

1 Introduction

1 Introduction

1.1 DC Motor Control Shield overview

The DC Motor Control Shield with TLE94112ES for Arduino UNO enables users to control up to 6 independent or 11 cascaded bi-directional *direct current (DC)* motors.

The shield can be controlled by a microcontroller using an *serial peripheral interface (SPI)*. For example, either an Arduino UNO R3 or the XMC1100 Boot Kit from Infineon can be used as master.

The board features an Infineon TLE94112ES, a twelve-fold half-bridge driver with integrated MOSFETs. Each half-bridge can drive peak currents up to 0.9 A and DC current in the range of 200 mA to 500 mA, depending on the application conditions and the number of activated outputs.

The DC Motor Control Shield has an active reverse polarity protection with the P-channel MOSFET IPD50P04P4L-11.

The DC Motor Control Shield can be easily connected to any Arduino board or to the XMC1100 Boot Kit using headers.

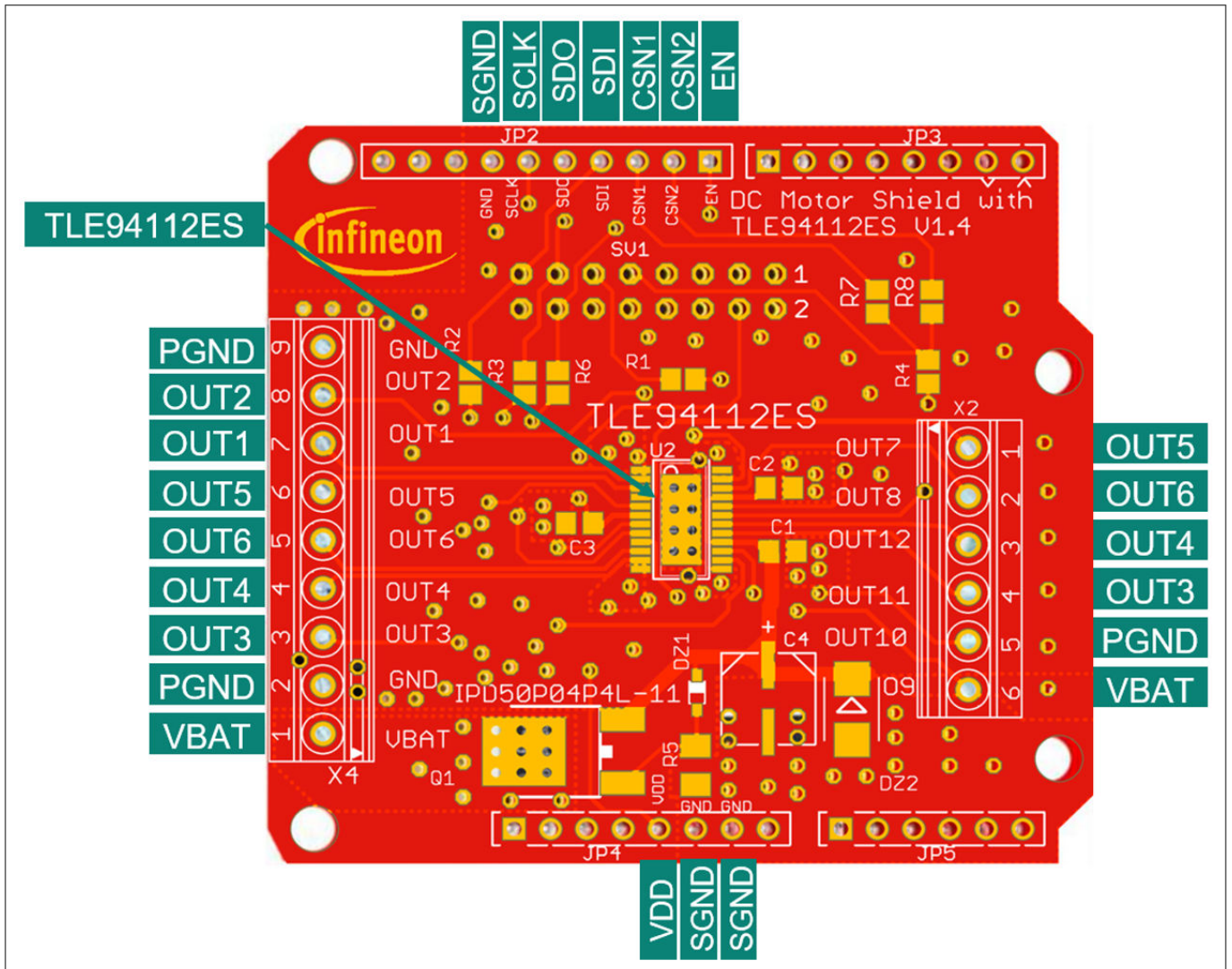

Figure 1 DC Motor Shield with TLE94112ES

1 Introduction

1.2 Key features

The DC Motor Control Shield has the following features:

- An Arduino UNO R3, XMC1100 Boot Kit, or similar board connected to the shield can control twelve half-bridges with the SPI
- Brushed DC Motor Control up to 0.9 A peak
 - 5.5 – 18 V normal operating input voltage
 - 18 – 20 V extended operating input voltage
 - Maximum input voltage up to 40 V (absolute maximum rating)
- Control of:
 - Six independent bidirectional DC motors
 - Eleven cascaded bidirectional DC motors
- SPI for high configurability and multiple diagnosis
- Protections:
 - Overtemperature
 - Overcurrent
 - Undervoltage
 - Overvoltage
- Detailed diagnosis per MOSFET:
 - Individual open load detection
 - Individual overcurrent detection
- Paralleling outputs for higher current capability
- Motor speed control by *pulse-width modulation (PWM)*
 - Three independent PWM generators
 - PWM frequency: 80 Hz, 100 Hz or 200 Hz
 - 8-bit resolution, 0.5% duty cycle steps
 - Active freewheeling for lower power dissipation
- Two shields can be stacked to control an increased number of motors
- Reverse polarity protection with IPD50P04P4L-11

1 Introduction

1.3 Application diagram for bi-directional DC motor applications

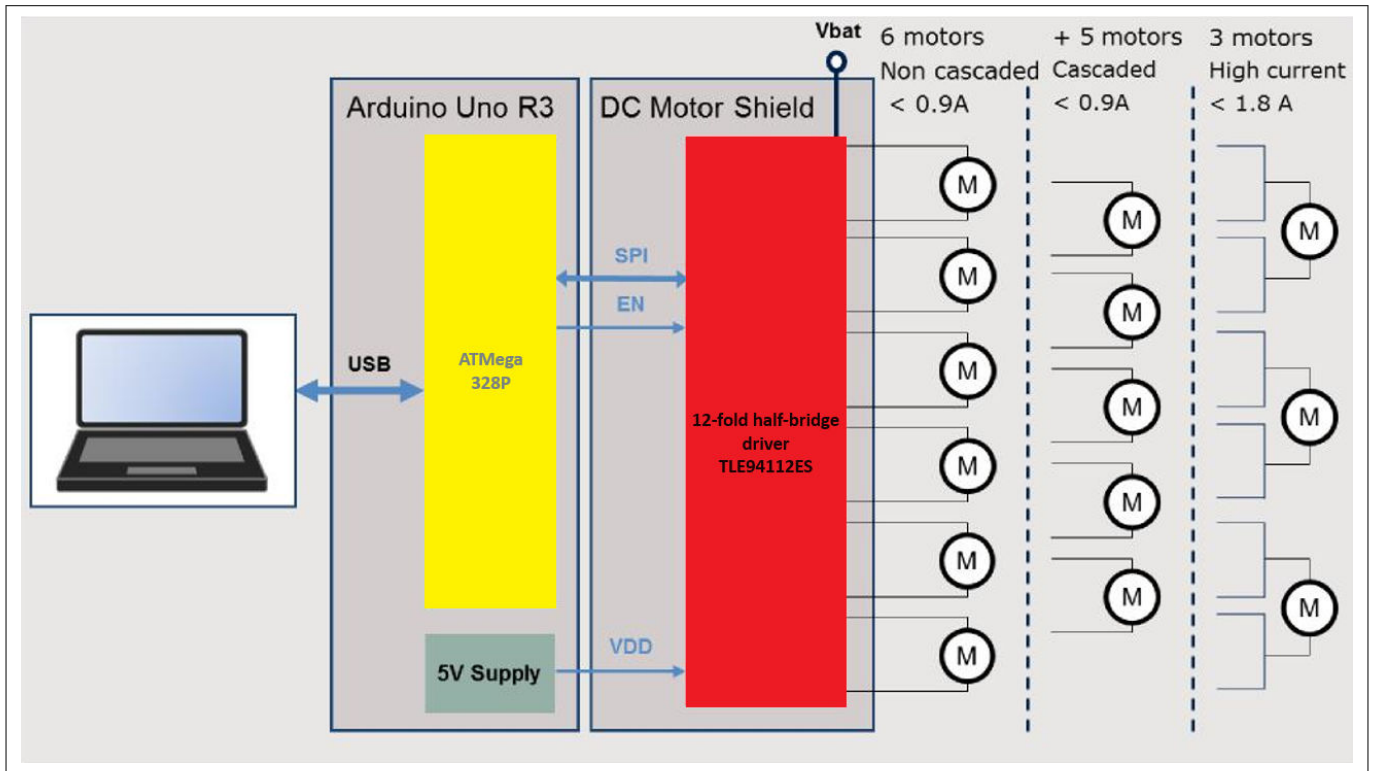

Figure 2 Simplified application diagram with TLE94112ES driving DC motors

Refer to the [TLE94112ES datasheet](#) for more information.

2 DC Motor Control Shield description

2 DC Motor Control Shield description

For a safe and optimized motor control design, some discrete components are needed. Some of them are dedicated to the motor application and some to the TLE94112ES.

Figure 4, Figure 5, and Figure 6 show the schematics and the corresponding layout of the DC Motor Control Shield with TLE94112ES.

2.1 Overview

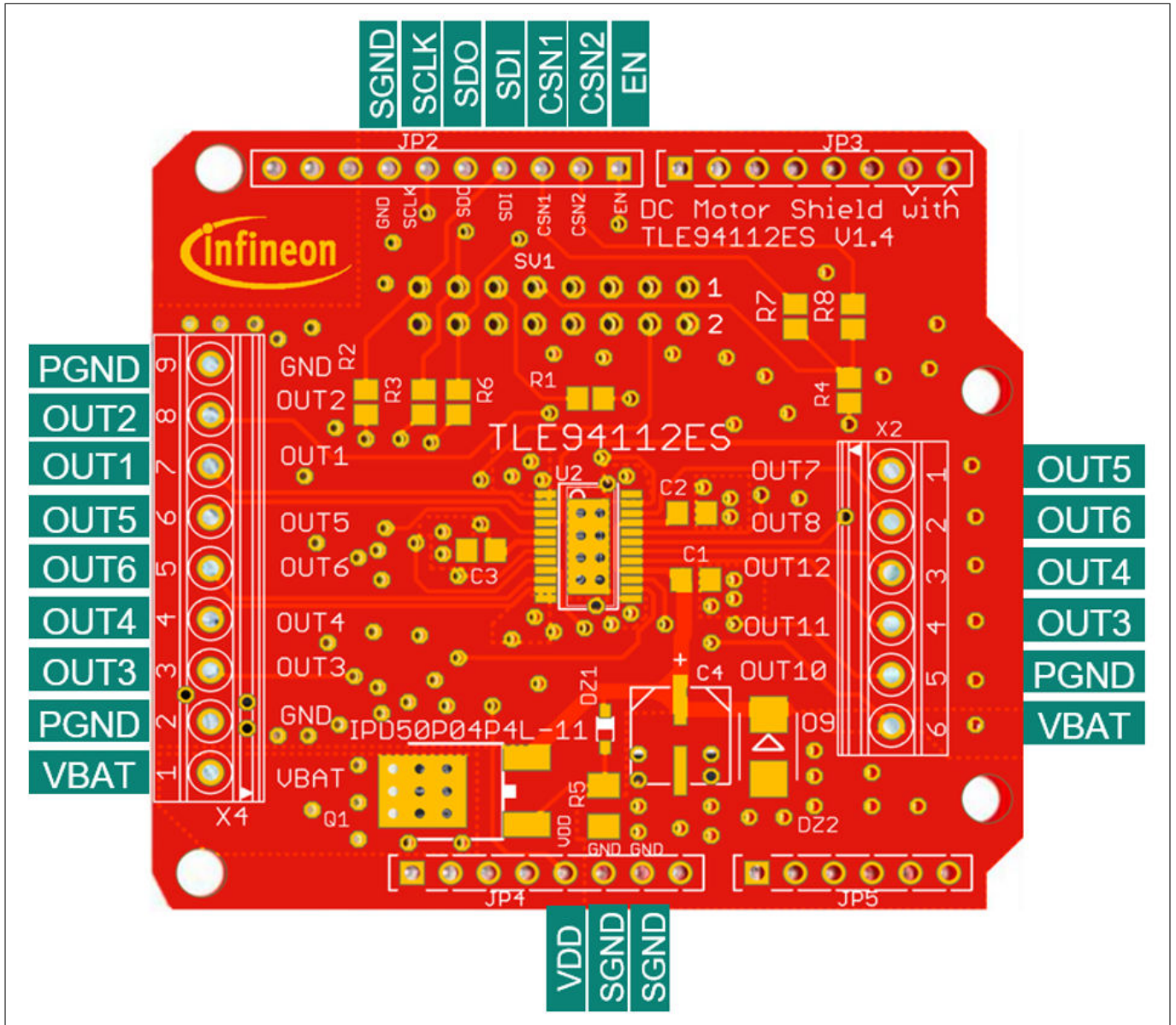

Figure 3 DC Motor Control Shield connectors

2 DC Motor Control Shield description

2.2 Schematics

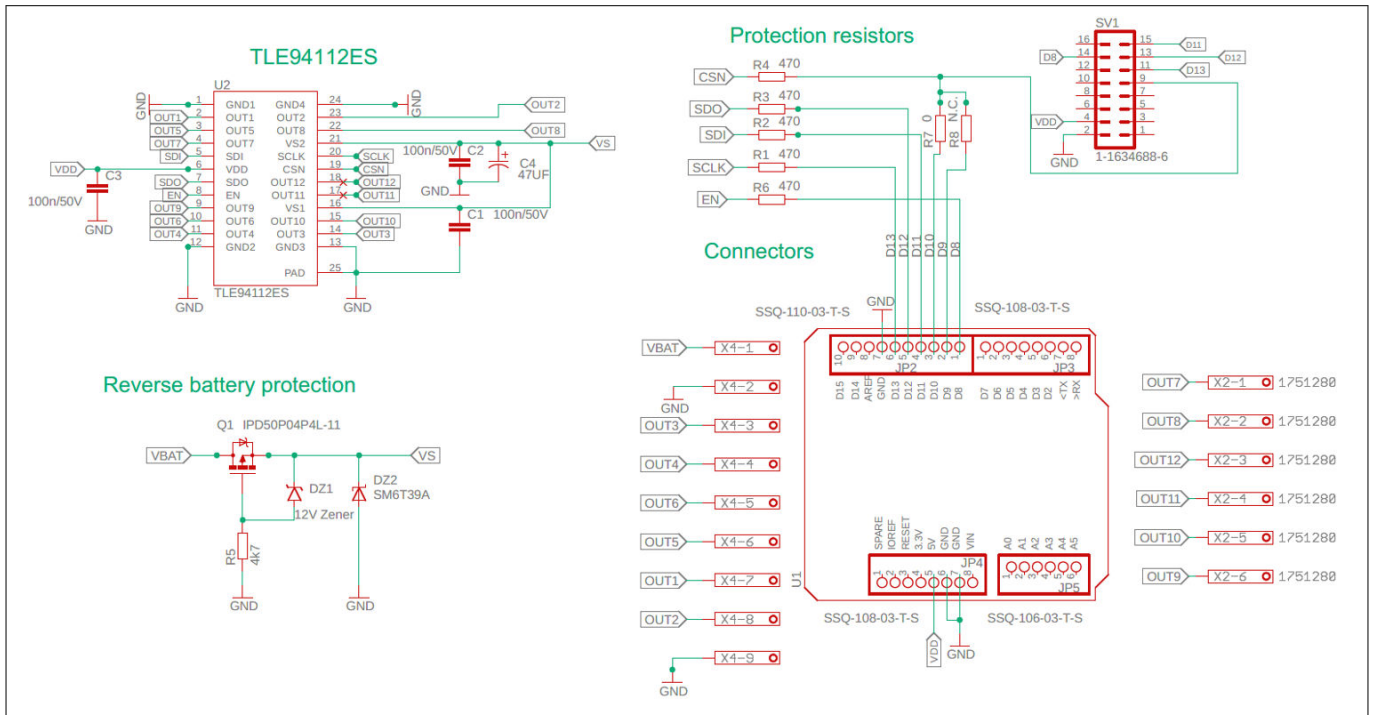

Figure 4 Schematics Motor Control Shield for Arduino with TLE94112ES

2.3 Layout

Figure 5 and Figure 6 show the layout of the DC Motor Shield with TLE94112ES.

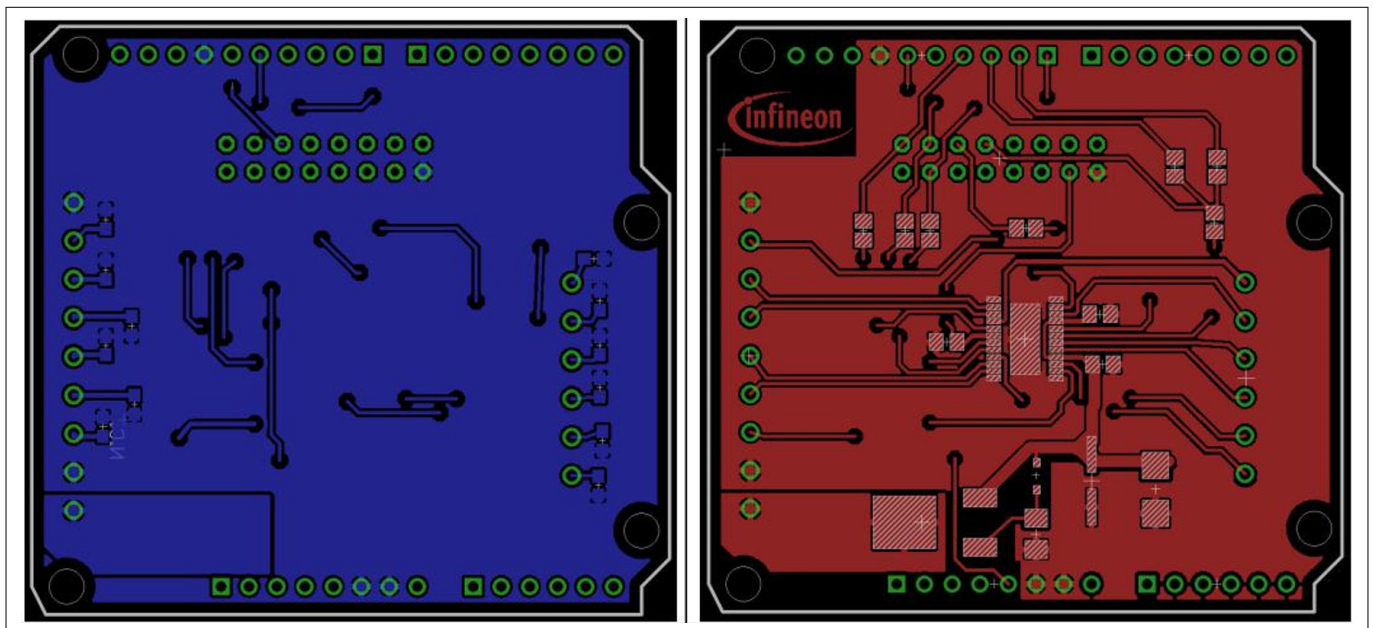

Figure 5 DC Motor Control Shield – Bottom and top layers

2 DC Motor Control Shield description

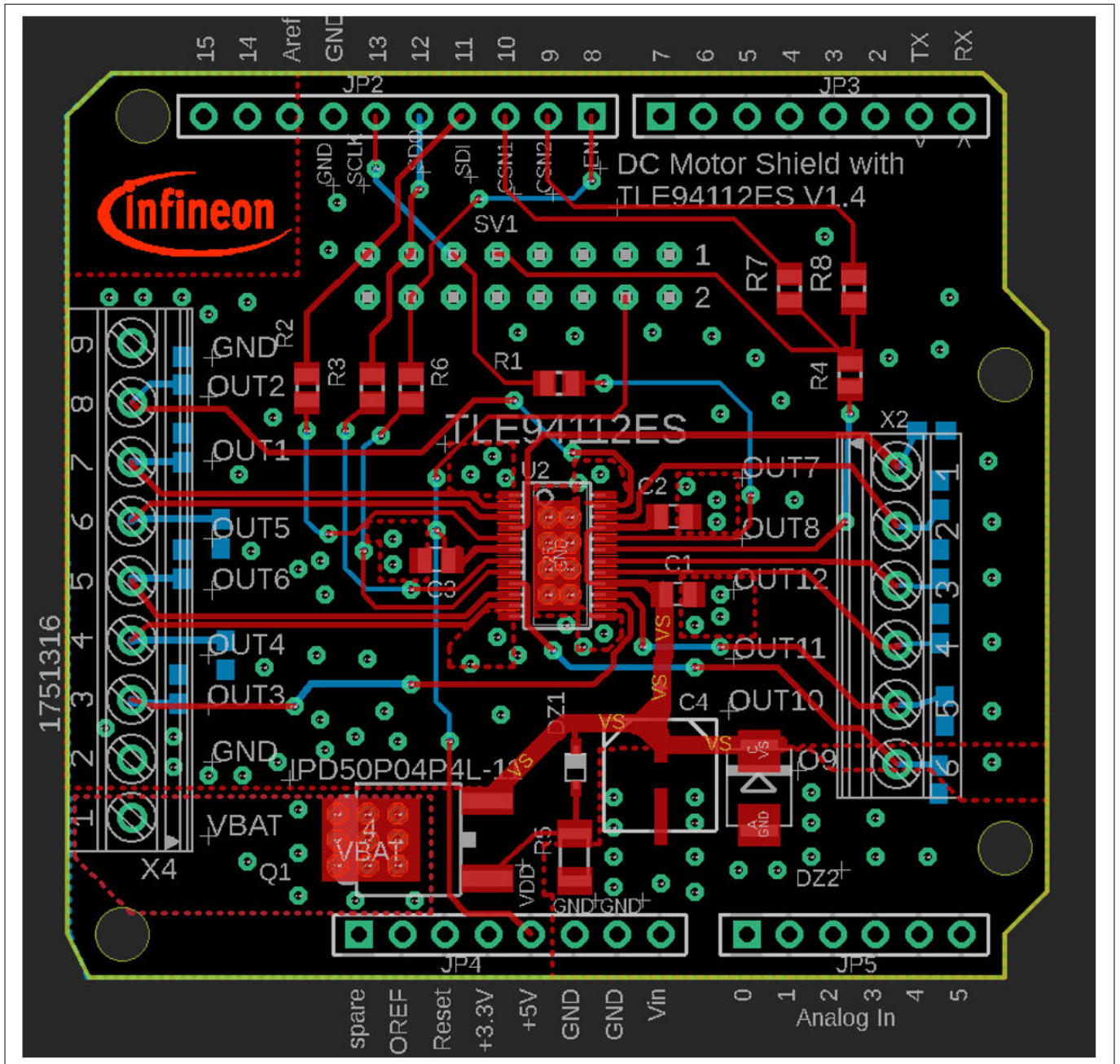

Figure 6 DC Motor Control Shield for Arduino with TLE94112ES – Layout

2 DC Motor Control Shield description

2.4 Bill of Material of the DC Motor Shield

| Part | Part number | Manufacturer | Description | Qty | Distributor | Order Number | Comment |
|--------------------|----------------------------|---------------------|----------------------------------|-----|-------------|---------------------|-------------|
| C1, C2, C3 | C0805C104K5RAC | Kemet | Capacitors 100n/50V | 3 | Farnell | 2070445 | |
| C4 | EEE-FT1H470AP | Panasonic | Capacitor 47µF/50V | 1 | Farnell | 1868425 | |
| DZ1 | MM3Z12VT1G | ON Semiconductor | Zener 12V | 1 | Farnell | 1431191 | |
| DZ2 | SM6T39A | STMicroelectronics | Transient suppressor diode, 39V | 1 | Farnell | 9802703 | |
| IC1 | TLE94112EL | Infineon | 12-fold half-bridge driver | 1 | Mouser | 726-TLE94112ELXUMA1 | |
| JP2 | JT254F-D180-850-110-10DO-G | MTCONN | Stacking header - 10 pins | 1 | | | |
| JP3, JP4 | JT254F-D180-850-108-10DO-G | MTCONN | Stacking header - 8 pins | 2 | | | |
| JP5 | JT254F-D180-850-106-10DO-G | MTCONN | Stacking header - 6 pins | 1 | | | |
| Q1 | IPD50P04P4L-11 | Infineon | 40V p-channel MOSFET | 1 | Farnell | 2443434 | |
| R1, R2, R3, R4, R6 | WR08X4700FTL | Walsin | Resistor | 5 | Farnell | 2502730 | |
| R5 | CRCW12064K70FKEA | Vishay | Resistor | 1 | Farnell | 1470013 | |
| R7 | WR08X000 | Walsin | Resistor | 1 | Farnell | 2502664 | |
| R8 | WR08X000 | Walsin | Resistor | 1 | Farnell | 2502664 | Not mounted |
| X2 | 31059106 | Metz Connect | 6-Position terminal block, 3.5mm | 1 | Farnell | 2434247 | |
| X4 | OSTTE090104 | On Shore Technology | 9-Position terminal block, 3.5mm | 1 | Digikey | ED2747 | |

Figure 7 DC Motor Control Shield with TLE94112ES – Bill of Material (BOM)

2.5 CSN1 and CSN2 Selection

Pin 10 of the Arduino UNO is used by default to control *chip select negated (CSN)* (Negated Chip Select) input of the TLE94112ES (Figure 8).

Alternatively, pin 9 of the Arduino UNO can also be used to stack two shields (refer to [Stacking two DC Motor Shields](#)). In this case, the resistor R7 (0 Ω, case 0805) must be desoldered (Figure 9) and a 0 Ω resistor (case 0805) must be soldered on the footprint of R8 (Figure 9).

2 DC Motor Control Shield description

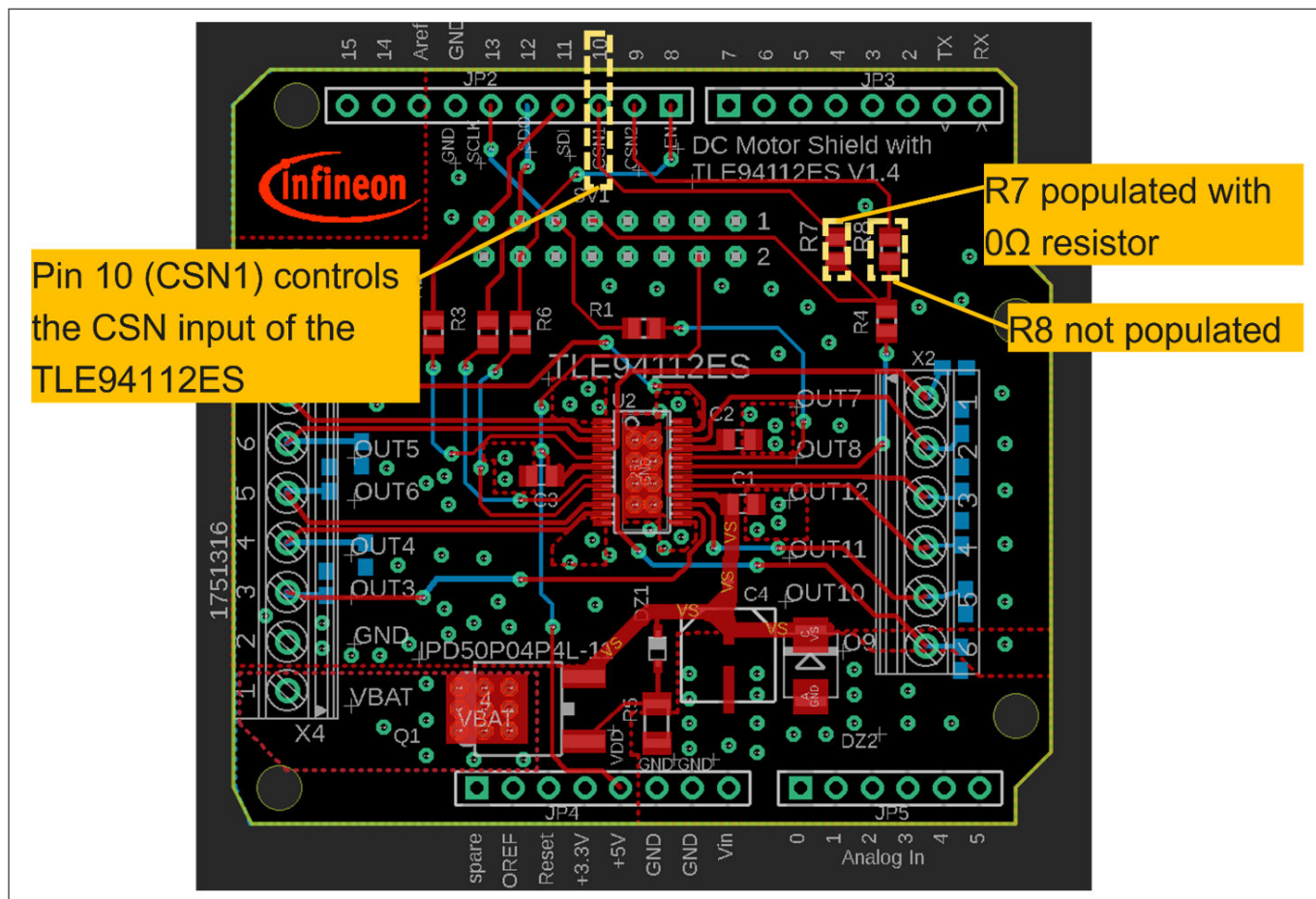

Figure 8 Control of CSN of TLE94112ES by pin 10 (CSN1)

2 DC Motor Control Shield description

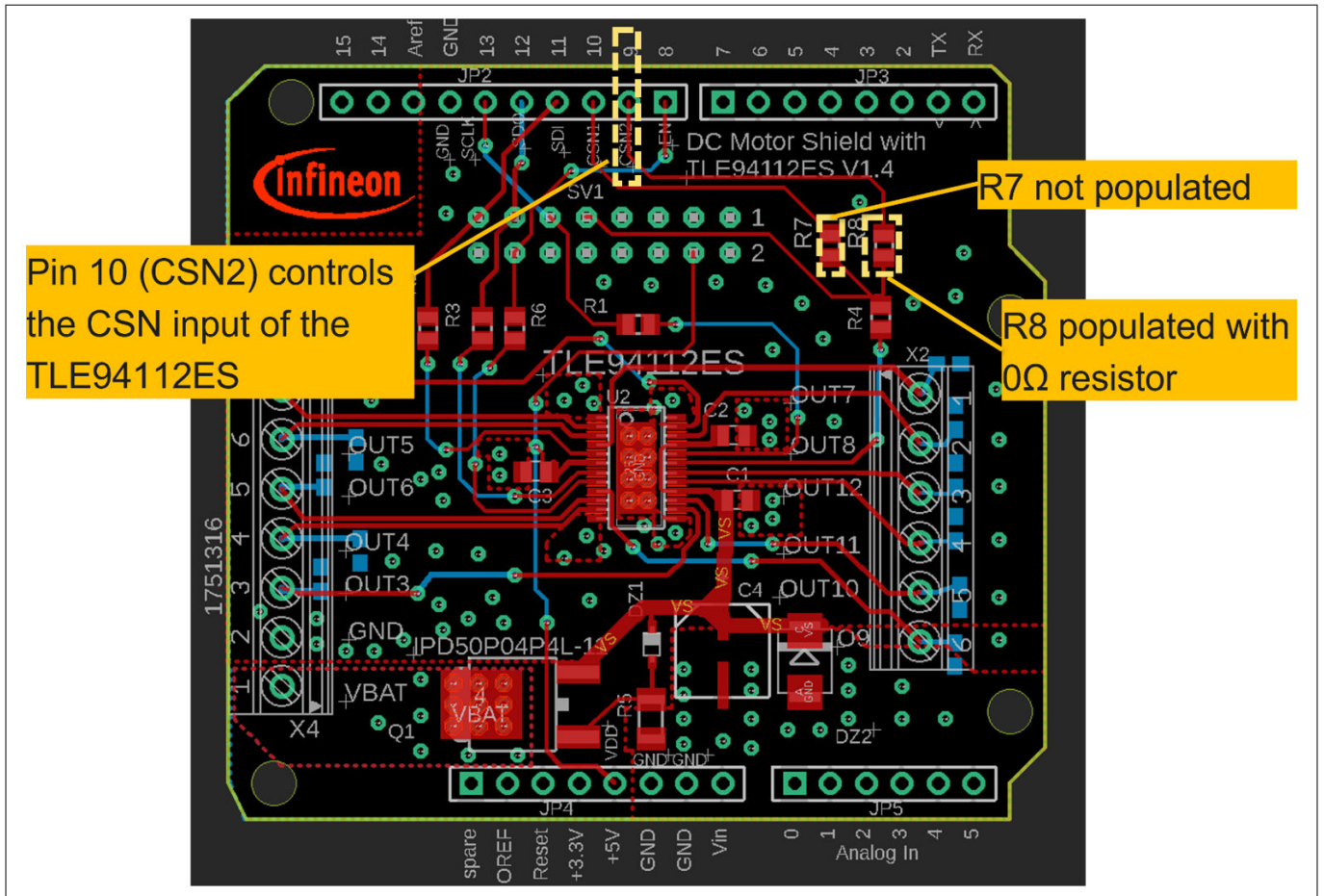

Figure 9 Control of CSN of TLE94112ES by Ppn 9 (CSN2)

2.6 Stacking two DC Motor Shields

It is possible to stack two DC Motor Shields to double the number of controlled motors. In this configuration, the CSN input of each TLE94112ES must be controlled individually by different microcontroller *general purpose input output (GPIO)*s:

- The TLE94112ES of one DC Motor shield is controlled by pin 10 (default setting, Figure 8)
- The TLE94112ES of the other DC Motor shield is controlled by pin 9 (Figure 9)

2.7 Pin assignment

To use the DC Motor Control Shield, the necessary control signals can be applied directly at the Arduino connectors with an Arduino, an XMC™ 1100 Boot Kit or any other microcontroller.

Figure 10 shows the pinout/connectors of the DC Motor Shield with TLE94112ES.

2 DC Motor Control Shield description

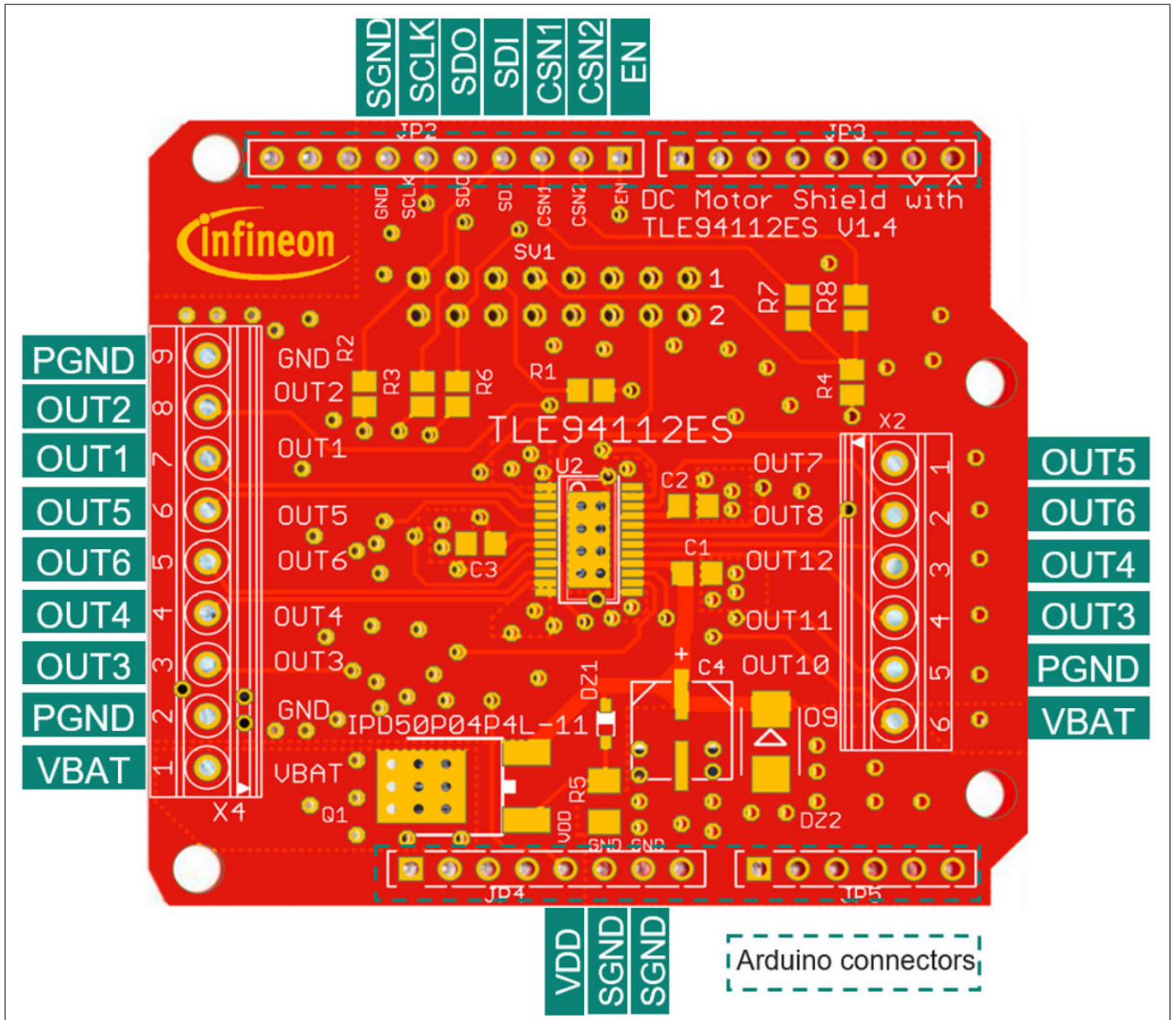

Figure 10 Connectors of DC Motor Shield

2.8 Pin definitions and functions

Table 2 Pin definitions and functions

| Pin | I/O ¹⁾ | Function |
|-----------------------------|-------------------|--|
| <i>signal ground (SGND)</i> | - | Signal GND: Connect to the signal GND of the microcontroller |
| <i>power ground (PGND)</i> | - | PGND: Connect one of the connectors to the power GND the application |

(table continues...)

¹ With respect to the TLE94112ES

2 DC Motor Control Shield description

Table 2 (continued) Pin definitions and functions

| Pin | I/O ¹⁾ | Function |
|------------------------------|-------------------|---|
| VBAT | - | Battery supply (5.5 – 20 V operating, 40V absolute maximum rating). Connect to the battery voltage of the application |
| VDD | - | Logic supply (5 V for Arduino UNO) |
| <i>serial clock (SCLK)</i> | I ²⁾ | Serial clock input |
| <i>serial data in (SDI)</i> | I ²⁾ | Serial data input |
| <i>serial data out (SDO)</i> | O ²⁾ | Serial data output |
| CSN1 | I ²⁾³⁾ | Negated chip select 1 |
| CSN2 | I ²⁾³⁾ | Negated chip select 2 |
| <i>enable (EN)</i> | I | Enable Input. Connect to a GPIO of the microcontroller. When set to low device goes in sleep mode with low current consumption. |
| OUT1-12 | O | Connectors for outputs of the half-bridges 1-12 |

¹⁾ With respect to the TLE94112ES

²⁾ Connect these signals to an SPI of the microcontroller

³⁾ Refer to chapters [CSN1 and CSN2 Selection](#) and [Stacking two DC Motor Shields](#)

3 TLE94112ES overview

3 TLE94112ES overview

The TLE94112ES is a protected twelve-fold half-bridge driver designed especially for automotive motion control applications such as *heating, ventilation, and air conditioning (HVAC)* flap DC motor control. It is part of a larger family offering half-bridge drivers from three outputs to twelve outputs with direct interface or *SPI*.

The half bridge drivers are designed to drive DC motor loads in sequential or parallel operation. Operation modes forward, reverse, brake and high impedance are controlled from a 16-bit SPI. It offers diagnosis features such as short circuit, open load, power supply failure and overtemperature detection.

In combination with its low quiescent current, this device is useful for automotive applications. The small fine pitch package with exposed pad, PG-SSOP-24, provides a good thermal performance and reduces *printed circuit board (PCB)* space and costs.

3.1 Key features of the TLE94112ES

- Twelve half-bridge power outputs
- Optimized *electromagnetic compatibility (EMC)* behavior
- Very low power consumption in sleep mode
- 3.3 V/5 V compatible inputs with hysteresis
- All outputs with overload and short circuit protection
- Independently diagnosable outputs (overcurrent, open load)
- Open load diagnostics in ON-state for all high-side and low-side
- Outputs with selectable open load thresholds (HS1, HS2)
- 16-bit Standard *SPI* with daisy chain and in-frame response capability for control and diagnosis
- Fast diagnosis with the global error flag
- PWM capable outputs for frequencies 80 Hz, 100 Hz and 200 Hz with 8-bit duty cycle resolution
- Overtemperature pre-warning and protection
- Overvoltage and undervoltage lockout
- Cross-current protection
- AEC-100 Qualified

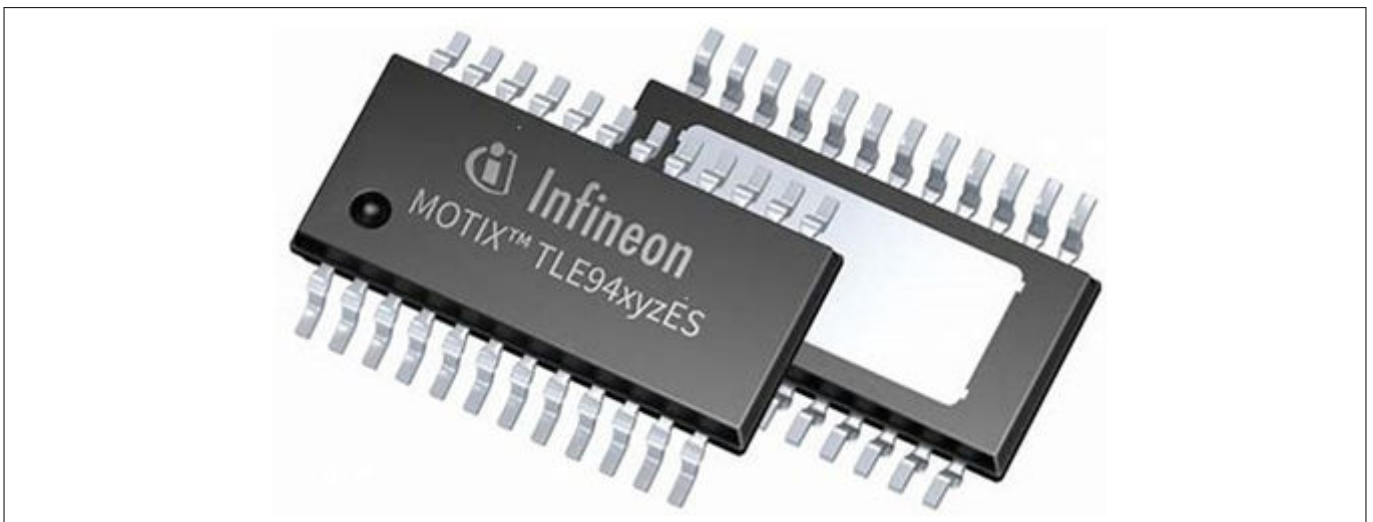

Figure 11 PG-SSOP-24 Package

3 TLE94112ES overview

3.2 Block diagram

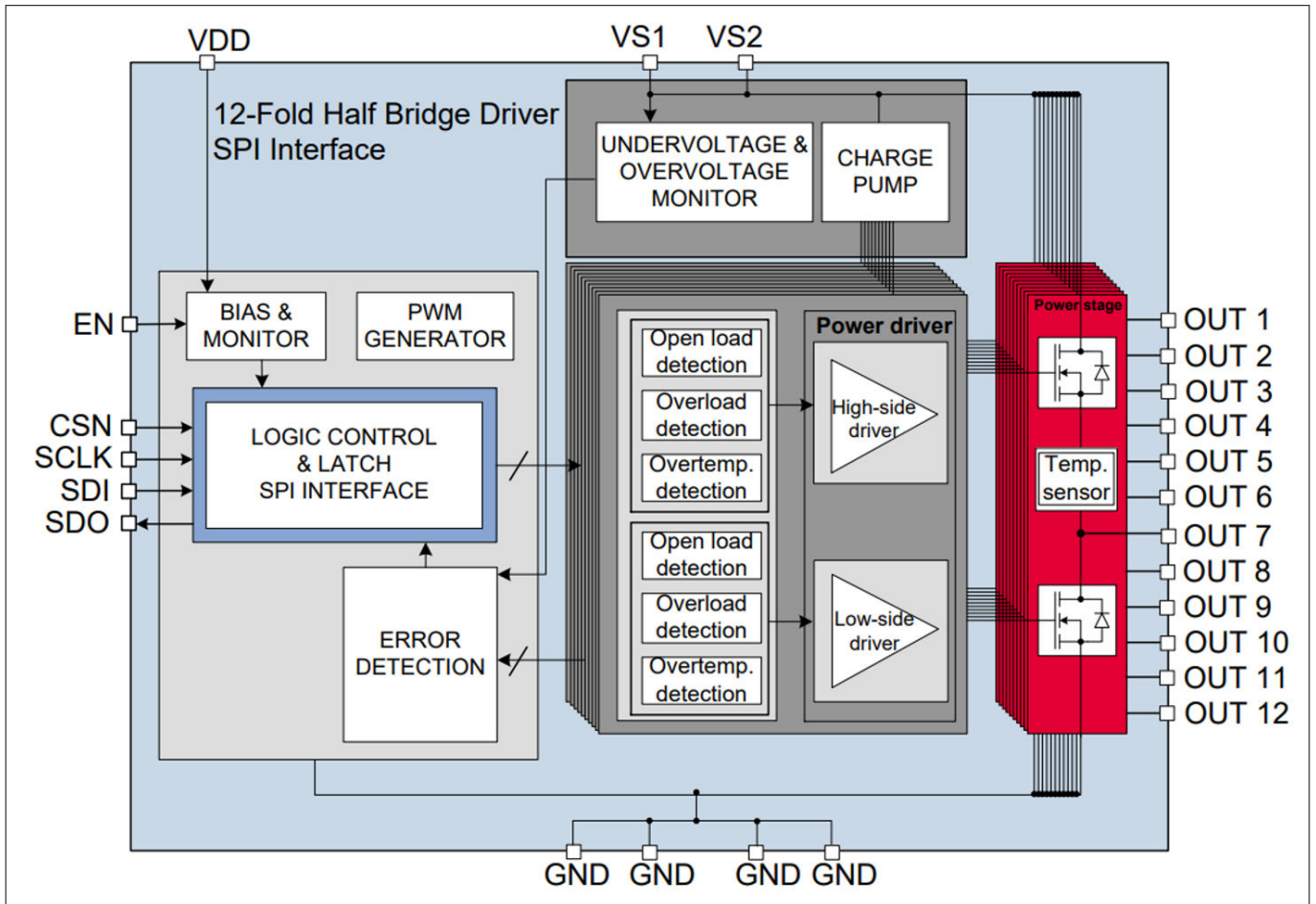

Figure 12 Block diagram TLE94112ES

3 TLE94112ES overview

3.3 Pin assignment

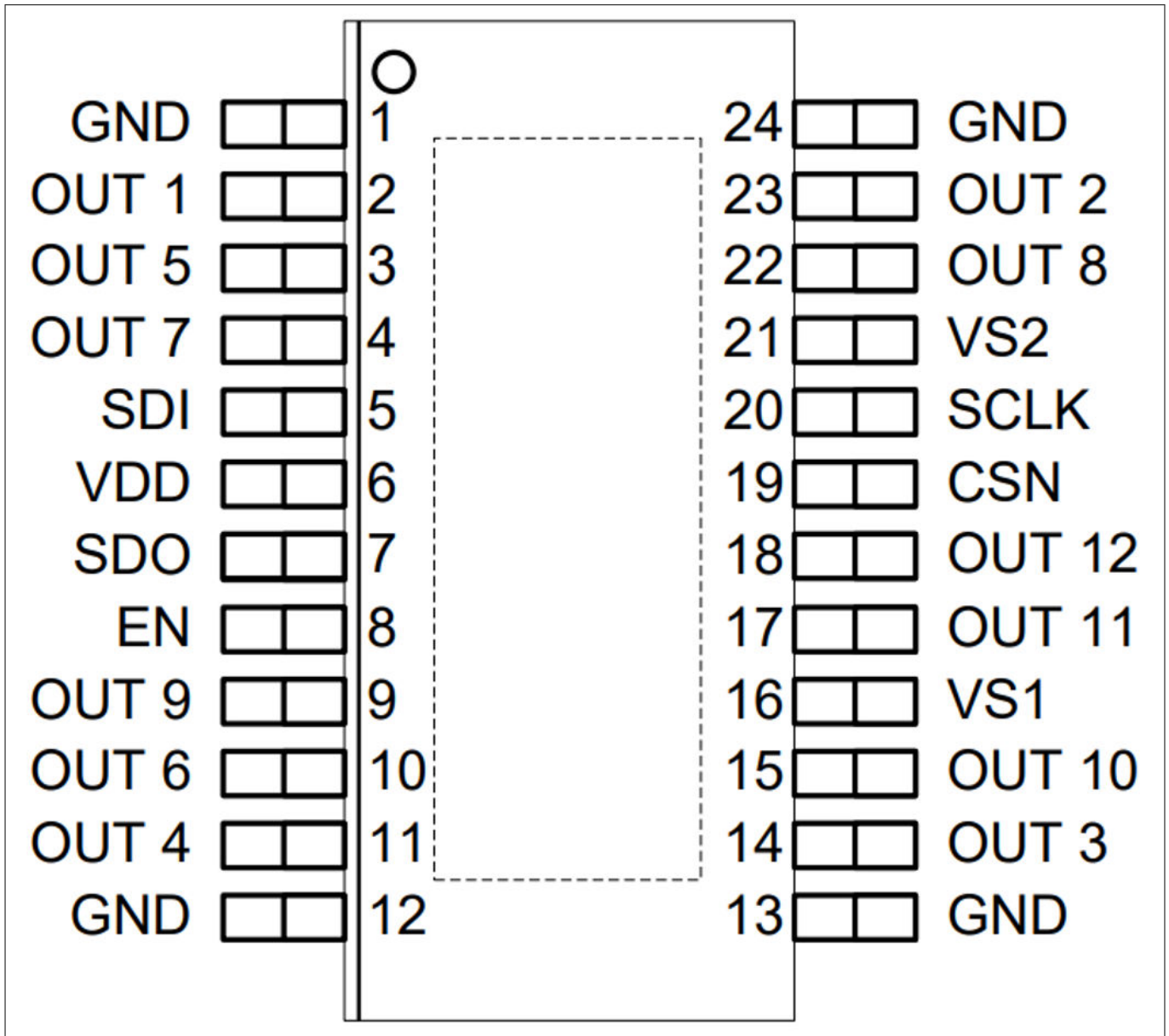

Figure 13 Pin assignment TLE94112ES (top view)

3.4 Pin definitions and functions

Table 3 Pin definitions and functions

| Pin | Symbol | Function |
|-----|--------|---|
| 1 | GND | Ground. All ground pins should be externally connected together |
| 2 | OUT 1 | Power half-bridge 1 |
| 3 | OUT 5 | Power half-bridge 5 |
| 4 | OUT 7 | Power half-bridge 7 |

(table continues...)

3 TLE94112ES overview

Table 3 (continued) Pin definitions and functions

| Pin | Symbol | Function |
|-----|--------|---|
| 5 | SDI | Serial data input with internal pull down |
| 6 | VDD | Logic supply voltage |
| 7 | SDO | Serial data output |
| 8 | EN | Enable with internal pull-down; Places device in standby mode by pulling the EN line Low |
| 9 | OUT 9 | Power half-bridge 9 |
| 10 | OUT 6 | Power half-bridge 6 |
| 11 | OUT 4 | Power half-bridge 4 |
| 12 | GND | Ground. All ground pins should be externally connected together |
| 13 | GND | Ground. All ground pins should be externally connected together |
| 14 | OUT 3 | Power half-bridge 3 |
| 15 | OUT 10 | Power half-bridge 10 |
| 16 | VS1 | Main supply voltage for power half bridges. VS1 should be externally connected to VS2 |
| 17 | OUT 11 | Power half-bridge 11 |
| 18 | OUT 12 | Power half-bridge 12 |
| 19 | CSN | Chip select NOT input with internal pull up |
| 20 | SCLK | Serial clock input with internal pull down |
| 21 | VS2 | Main supply voltage for power half bridges. VS1 should be externally connected to VS1 |
| 22 | OUT 8 | Power half-bridge 8 |
| 23 | OUT 2 | Power half-bridge 2 |
| 24 | GND | Ground. All ground pins should be externally connected together |
| EDP | - | Exposed die pad; For cooling purpose only - not usable as electrical ground. Electrical ground must be provided by pins 1, 12, 13, 24 |

4 Getting started

4 Getting started

4.1 Target applications

The main application targeted by the TLE94112ES is brushed DC motor control with peak currents below 0.9 A. Several outputs can be connected in parallel to increase the current capability.

Besides motor control, the TLE94112ES can drive any other inductive, capacitive and resistive loads within the device electrical characteristics such as monostable relays, bistable relays and *light-emitting diode (LED)*s.

4.2 Getting started: shield

- Connect the brushed DC motors to the corresponding output connectors (OUT_x, x=1... 12). Refer to [Figure 14](#)
 - Choose a DC adapter
 - The extended operating input range of the shield (VBAT) is 5.5 V – 20 V DC
- Note:** *The absolute maximum rating is 40 V*
- Connect the DC Motor Shield to an Arduino UNO R3 or an XMC™ 1100 Boot Kit. The control signals between the TLE94112ES and the Arduino UNO R3 or XMC1100 are linked to each other ([Figure 15](#))
 - Connect the USB cable to (for example) the Arduino UNO R3 ([Figure 16](#)) or the micro USB to the XMC™ 1100 Boot Kit
 - After the software is flashed to the microcontroller, a standard mobile phone charging device can be used to supply the XMC™ 1100 Boot Kit
 - Program the controller board with the motor control software with the corresponding IDE
 - Connect the DC adapter to the Power Shield (VBAT and GND, see [Figure 16](#))
 - Turn on the power

4 Getting started

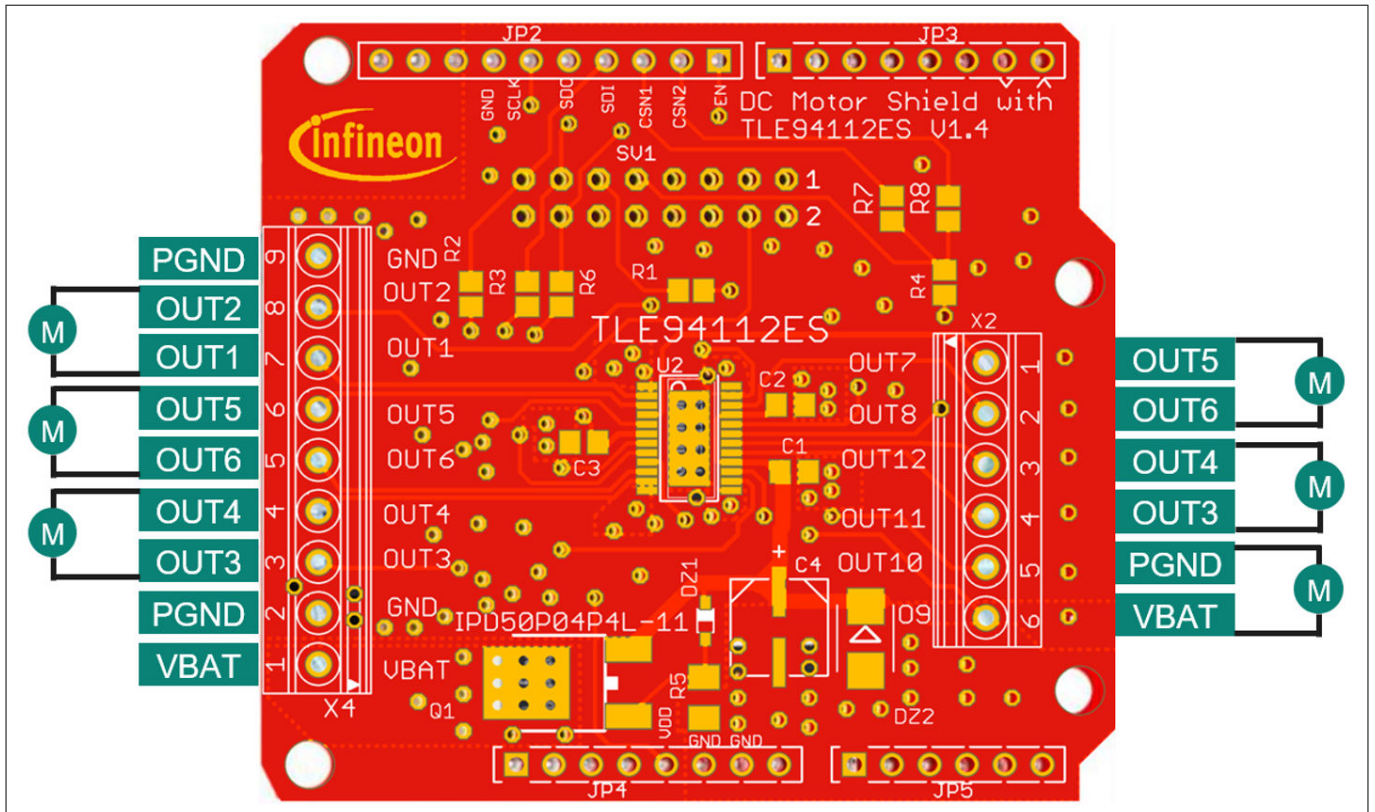

Figure 14 Motor Control Shield connectors

4 Getting started

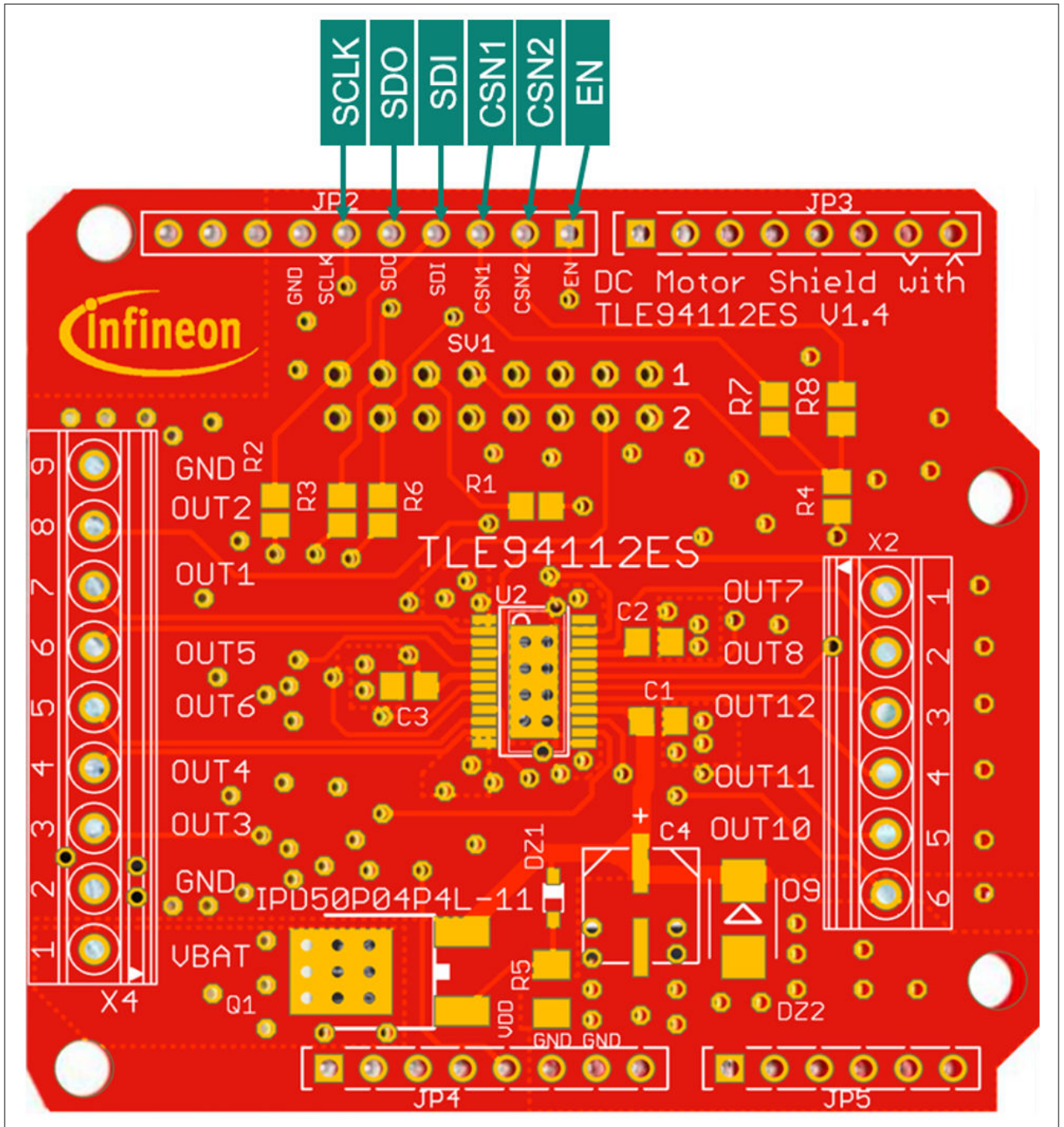

Figure 15 Control signals between DC motor shield and Arduino Uno

4 Getting started

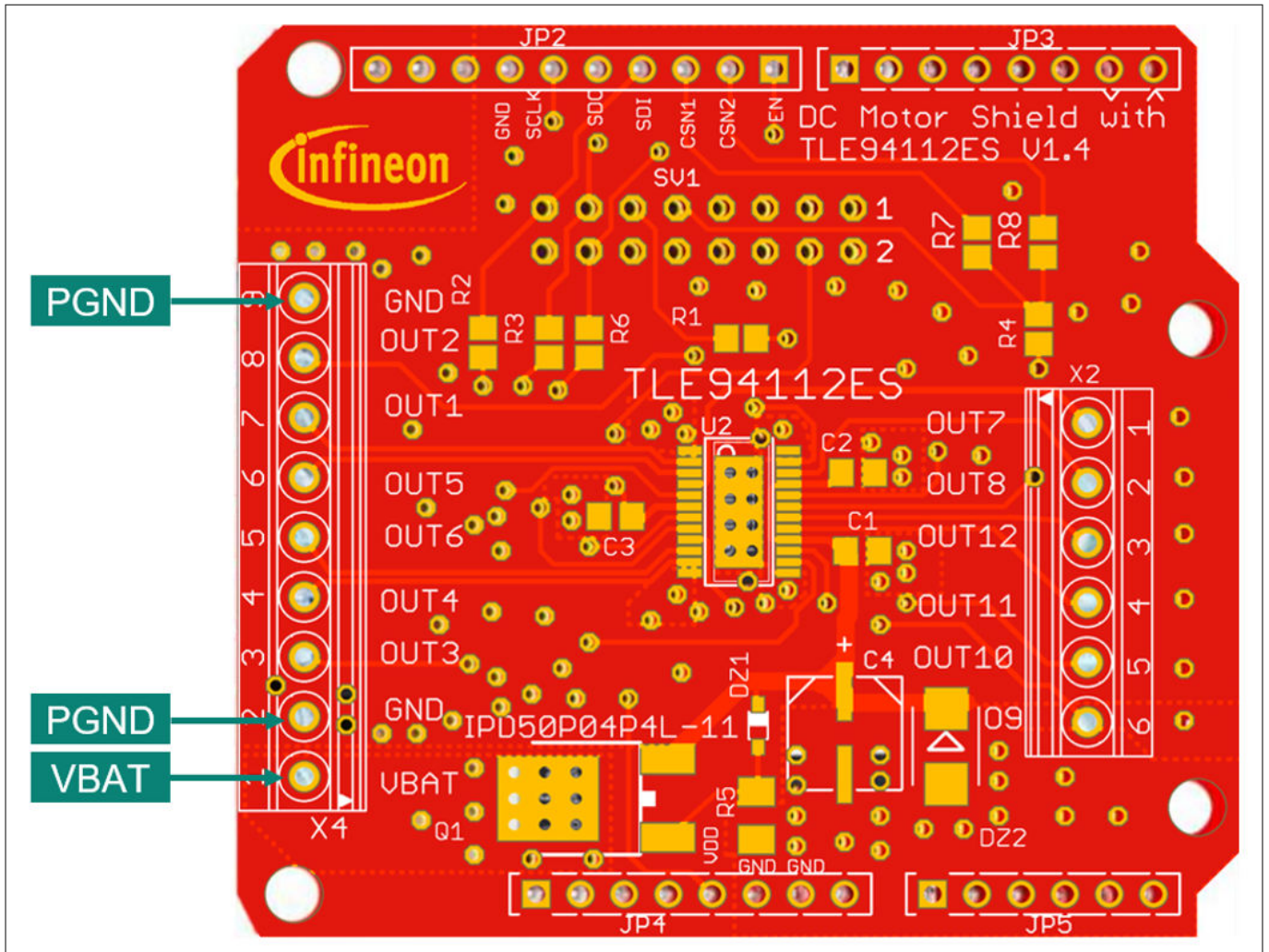

Figure 16 Supply connection

4.3 Getting started: software

1. Download the sketch example for the DC Motor Shield with TLE94112 for Arduino ([TLE94112ES_Shield_Arduino_Example_Sketch](#))
2. Connect the Arduino UNO with a USB cable to the USB port of your PC
3. Download and install the Arduino IDE: free Development Platform for Code Generation from Arduino ([Arduino IDE](#))
4. Start the Arduino IDE and import the project file ([TLE94112ES_Shield_Arduino_Example_Sketch](#))
5. Flash the sketch to the Arduino UNO

4.4 Sketch example for DC motor shield

The [TLE94112ES-Sketch](#) example is intended to operate with shields configured as shown in [Figure 4](#): The CSN input of the TLE94112ES is controlled by pin 10 of the Arduino UNO board.

Sketch content:

- Declaration of register addresses
- Read, write and clear registers of the TLE94112ES

4 Getting started

- Display the *SPI* frames sent/received by the TLE94112ES on the IDE Serial Monitor
- Motors activation in loop:
 1. The motor connected between OUT1/OUT2 operates in *PWM* mode/100 Hz
 - During 2 seconds: Low-Side 2 (LS2) ON, High-Side 1 (HS1) ON with 90% duty cycle/100 Hz
 - During 2 seconds: LS2 ON, HS1 ON with 20% duty cycle/100 Hz
 - Brake to GND for 300 ms: LS1 and LS2 ON
 2. Activation of six motors (connected to OUT1/2, OUT3/4, OUT5/6, OUT7/8, OUT9/10 and OUT11/12)
 - 1st second:
 - LS1, LS3, LS5, LS7, LS9, LS11 ON
 - HS2, HS4, HS6, HS8, HS10, HS12 ON
 - 300 ms brake to *ground (GND)*
 - LS1-12 ON
 - followed by 1 second:
 - HS1, HS3, HS5, HS7, HS9, HS11 ON
 - LS2, LS4, LS6, LS8, LS10, LS12 ON
 - Brake to GND for 300 ms:
 - LS1-12 ON

Glossary

Glossary

CSN

chip select negated (CSN)

A low-active input pin, which enables communication with the specific peripheral.

DC

direct current (DC)

One-directional flow of electric charge. An electrochemical cell is a prime example of DC power. Direct current may flow through a conductor such as a wire, but can also flow through semiconductors, insulators, or even through a vacuum as in electron or ion beams. The electric current flows in a constant direction, distinguishing it from alternating current (AC).

EMC

electromagnetic compatibility (EMC)

The ability of electrical equipment and systems to function acceptably in their electromagnetic environment, by limiting the unintentional generation, propagation and reception of electromagnetic energy which may cause unwanted effects such as electromagnetic interference (EMI) or even physical damage in operational equipment.

EN

enable (EN)

A signal to enable certain device functions.

GND

ground (GND)

GPIO

general purpose input output (GPIO)

HVAC

heating, ventilation, and air conditioning (HVAC)

Heating, ventilation, and air conditioning is the use of various technologies to control the temperature, purity, and humidity of the air in an enclosed space.

LED

light-emitting diode (LED)

A semiconductor circuit that emits light when activated.

PCB

printed circuit board (PCB)

A board that mechanically supports and electrically connects electronic components using conductive tracks, pads, and other features etched from copper sheets laminated onto a non-conductive substrate.

PGND

power ground (PGND)

A reference potential for power circuits.

Glossary

PWM

pulse-width modulation (PWM)

A technique to encode an analog value into the duty cycle of a pulsing signal with arbitrary amplitude.

SCLK

serial clock (SCLK)

A signal that is used in synchronous serial communication protocols, to synchronize the transfer of data between devices.

SDI

serial data in (SDI)

An input signal on a device where data is received from another serial peripheral interface device.

SDO

serial data out (SDO)

An output signal on a device where data is sent out to another serial peripheral interface device.

SGND

signal ground (SGND)

A reference potential for signal processing.

SPI

serial peripheral interface (SPI)

A synchronous serial communication interface specification used for inter-chip communication, primarily in embedded systems.

Revision history

Revision history

| Document version | Date of release | Description of changes |
|------------------|-----------------|---|
| Rev. 1.10 | 2024-08-28 | <ul style="list-style-type: none">Functional description and figures updatedGlossary added |
| Rev 1.00 | 2017-02-13 | <ul style="list-style-type: none">Initial release |

Trademarks

All referenced product or service names and trademarks are the property of their respective owners.

Edition 2024-08-28

Published by

Infineon Technologies AG

81726 Munich, Germany

© 2024 Infineon Technologies AG

All Rights Reserved.

Do you have a question about any aspect of this document?

Email: erratum@infineon.com

Document reference

IFX-tho1721033372284

Important notice

The information given in this document shall in no event be regarded as a guarantee of conditions or characteristics ("Beschaffheitsgarantie").

With respect to any examples, hints or any typical values stated herein and/or any information regarding the application of the product, Infineon Technologies hereby disclaims any and all warranties and liabilities of any kind, including without limitation warranties of non-infringement of intellectual property rights of any third party.

In addition, any information given in this document is subject to customer's compliance with its obligations stated in this document and any applicable legal requirements, norms and standards concerning customer's products and any use of the product of Infineon Technologies in customer's applications.

The data contained in this document is exclusively intended for technically trained staff. It is the responsibility of customer's technical departments to evaluate the suitability of the product for the intended application and the completeness of the product information given in this document with respect to such application.

Warnings

Due to technical requirements products may contain dangerous substances. For information on the types in question please contact your nearest Infineon Technologies office.

Except as otherwise explicitly approved by Infineon Technologies in a written document signed by authorized representatives of Infineon Technologies, Infineon Technologies' products may not be used in any applications where a failure of the product or any consequences of the use thereof can reasonably be expected to result in personal injury.

Mouser Electronics

Authorized Distributor

Click to View Pricing, Inventory, Delivery & Lifecycle Information:

[Infineon:](#)

[TLE94112ESSHIELDTOBO1](#)