

AIROC™ CYW20829: CYW920829B0M2P4XXI100-EVK Module Evaluation Kit user guide

About this document

Scope and purpose

The Infineon AIROC™ CYW20829 Bluetooth® Low Energy module Evaluation Kit (CYW920829B0M2P4XXI100-EVK) enables evaluation, prototyping, and development of a wide array of Internet of Things (IoT) applications using the AIROC™ CYW20829 module, a low-power and high-performance Bluetooth® Low Energy MCU. The system features an Arm® Cortex® - M33 core with the programmable and reconfigurable analog and digital blocks.

It is a combination of an MCU with the following:

- Sigma delta switched-cap Analog-to-digital converter (ADC) for audio and DC measurements
- Seven 16-bit and two 32-bit Timer/Counter Pulse-Width Modulator (TCPWM) blocks
- 98 dBm LE-1 Mbps RX sensitivity, -105 dBm LE-LR at 125 kbps, -101 dBm LE-LR at 500 Kbps, and an integrated PA with 10 dBm TX output power for better link budgets
- Serial Memory Interface (SMIF) for external flash with encryption support
- Serial communication interfaces such as UART, I²C, and Quad-SPI
- Wake from Deep Sleep I²C (sensors sitting on the I²C interface should be able to wake up the MCU)
- Two pulse density modulation (PDM) channels and one I²S channel with Time Division Multiplexed (TDM) mode

Intended audience

This document is intended for users interested in the CYW920829B0M2P4XXI100-EVK. This comes in two variants as given below

- [CYW920829B0M2P4TAI100-EVK](#)- Trace antenna module EVK
- [CYW920829B0M2P4EPI100-EVK](#) - External RF pad module EVK

Important notice

Important notice

“Evaluation Boards and Reference Boards” shall mean products embedded on a printed circuit board (PCB) for demonstration and/or evaluation purposes, which include, without limitation, demonstration, reference and evaluation boards, kits and design (collectively referred to as “Reference Board”).

Environmental conditions have been considered in the design of the Evaluation Boards and Reference Boards provided by Infineon Technologies. The design of the Evaluation Boards and Reference Boards has been tested by Infineon Technologies only as described in this document. The design is not qualified in terms of safety requirements, manufacturing and operation over the entire operating temperature range or lifetime.

The Evaluation Boards and Reference Boards provided by Infineon Technologies are subject to functional testing only under typical load conditions. Evaluation Boards and Reference Boards are not subject to the same procedures as regular products regarding returned material analysis (RMA), process change notification (PCN) and product discontinuation (PD).

Evaluation Boards and Reference Boards are not commercialized products, and are solely intended for evaluation and testing purposes. In particular, they shall not be used for reliability testing or production. The Evaluation Boards and Reference Boards may therefore not comply with CE or similar standards (including but not limited to the EMC Directive 2004/EC/108 and the EMC Act) and may not fulfill other requirements of the country in which they are operated by the customer. The customer shall ensure that all Evaluation Boards and Reference Boards will be handled in a way which is compliant with the relevant requirements and standards of the country in which they are operated.

The Evaluation Boards and Reference Boards as well as the information provided in this document are addressed only to qualified and skilled technical staff, for laboratory usage, and shall be used and managed according to the terms and conditions set forth in this document and in other related documentation supplied with the respective Evaluation Board or Reference Board.

It is the responsibility of the customer’s technical departments to evaluate the suitability of the Evaluation Boards and Reference Boards for the intended application, and to evaluate the completeness and correctness of the information provided in this document with respect to such application.

The customer is obliged to ensure that the use of the Evaluation Boards and Reference Boards does not cause any harm to persons or third-party property.

The Evaluation Boards and Reference Boards and any information in this document is provided "as is" and Infineon Technologies disclaims any warranties, express or implied, including but not limited to warranties of non-infringement of third-party rights and implied warranties of fitness for any purpose, or for merchantability.

Infineon Technologies shall not be responsible for any damages resulting from the use of the Evaluation Boards and Reference Boards and/or from any information provided in this document. The customer is obliged to defend, indemnify and hold Infineon Technologies harmless from and against any claims or damages arising out of or resulting from any use thereof.

Infineon Technologies reserves the right to modify this document and/or any information provided herein at any time without further notice.

Safety precautions

Safety precautions

Note: Please note the following warnings regarding the hazards associated with development systems

Table 1 Safety precautions

	<p>Caution: <i>The evaluation or reference board contains parts and assemblies sensitive to electrostatic discharge (ESD). Electrostatic control precautions are required when installing, testing, servicing or repairing the assembly. Component damage may result if ESD control procedures are not followed. If you are not familiar with electrostatic control procedures, refer to the applicable ESD protection handbooks and guidelines.</i></p>
---	---

Table of contents

Table of contents

About this document..... 1

Important notice 2

Safety precautions..... 3

Table of contents..... 4

1 Introduction 6

1.1 CYW920829B0M2P4XXI100-EVK kit contents.....6

1.2 CYW920829B0M2P4XXI100-EVK details 7

1.3 ModusToolbox™9

1.3.1 Select a new workspace.....10

1.3.2 Create a new ModusToolbox™ application10

1.3.3 Select CYW20829 MCU-based target hardware.....11

1.3.4 ModusToolbox™ code examples12

1.3.5 Related code examples14

1.3.6 ModusToolbox™ help14

1.4 Getting started.....14

1.5 IoT resources and technical support14

2 Kit operation15

2.1 Theory of operation.....15

2.2 Jumpers.....19

2.3 Buttons and switches21

2.4 Arduino-compatible headers21

2.5 Other headers24

2.6 USB serial interface chip25

2.7 Kit power supply.....25

2.8 Test points25

2.9 Current measurement.....25

2.10 SWD debugging26

2.11 Pin configuration.....26

3 Hardware27

3.1 Carrier module.....27

3.1.1 CYW20829 Module M.2 Board Details27

3.1.2 Antenna27

3.1.3 Crystal.....27

3.2 Base board.....27

3.2.1 Serial communication between CYW20829 and PSoC™ 5LP KitProg3.....28

3.2.2 Power.....28

3.2.3 Device reset33

3.2.4 Thermistor34

3.2.5 External serial flash34

3.2.6 Inertial measurement unit (IMU)35

3.2.7 LEDs35

3.2.8 Push buttons36

3.2.9 Digital microphone (DMIC).....36

3.2.10 Analog microphone (AMIC)37

3.2.11 RGB LED37

3.2.12 10-pin SWD header.....38

Table of contents

3.2.13	Arduino-compatible and extended headers	38
4	CYW20829 device I/O mapping	40
5	Kit rework	43
5.1	SMIF interface for baseboard flash	43
5.2	UART interface on headers compatible with Arduino-standard	45
5.3	SPI interface selection.....	46
5.4	I2S interface selection.....	47
5.5	IMU interrupt signal selection.....	48
6	Frequently asked questions	49
	References.....	50
	Glossary	51
	Revision history.....	53
	Disclaimer.....	54

1 Introduction

The Infineon AIROC™ CYW20829 Bluetooth® Low Energy module Evaluation Kit (CYW920829B0M2P4XXI100-EVK) enables the evaluation, prototyping, and development of a wide array of IoT applications using the AIROC™ CYW20829 module, a low-power and high-performance Bluetooth® Low Energy Module.

The AIROC™ CYW20829 Bluetooth® Low Energy module provides reliable Bluetooth® connectivity that is core-spec compliant to 5.4. It is a highly integrated device with an Arm® Cortex® - M33 that is dedicated to customer applications and an integrated power amplifier with 10 dBm of transmitting output power. The AIROC™ CYW20829 module is ideal for a wide range of applications in home and industrial automation, sensors, lighting, Bluetooth® mesh, remote controls, and any other Bluetooth® LE connected to the IoT application.

CYW20829 Bluetooth® Low Energy module EVK (CYW920829B0M2P4XXI100-EVK) and ModusToolbox™ software and tools form a powerful but easy-to-use toolset that helps the developers to create amazing Bluetooth® enabled IoT solutions. CYW920829B0M2P4XXI100-EVK offers footprint compatibility with Arduino shields. The development environment is compatible with Windows, macOS, and Linux operating systems. In addition, the kit features an onboard programmer/debugger (KitProg3). The CYW20829 Evaluation kit supports 1.8 V, 3.3 V, and coin-cell operation.

Note: This kit supports ModusToolbox™ software 3.0 (or later).

The EVK is available through the Infineon Online Store or through our distributors.

- [CYW920829B0M2P4TAI100-EVK](#) - Trace antenna module EVK
- [CYW920829B0M2P4EPI100-EVK](#) - External RF pad module EVK

1.1 CYW920829B0M2P4XXI100-EVK kit contents

CYW920829B0M2P4TAI100-EVK comes in two variants.:

The CYW920829B0M2P4TAI100-EVK kit includes the following:

- CYW920829B0M2P4TAI100-EVK, Trace antenna module EVK
- USB 2.0 Type-A to Micro-B cable
- Six jumper wires (five inches each)
- Quick start guide

The CYW920829B0M2P4EPI100-EVK kit includes the following:

- CYW920829B0M2P4EPI100-EVK, External RF pad module EVK
- USB 2.0 Type-A to Micro-B cable
- Six jumper wires (five inches each)
- Quick start guide

Introduction

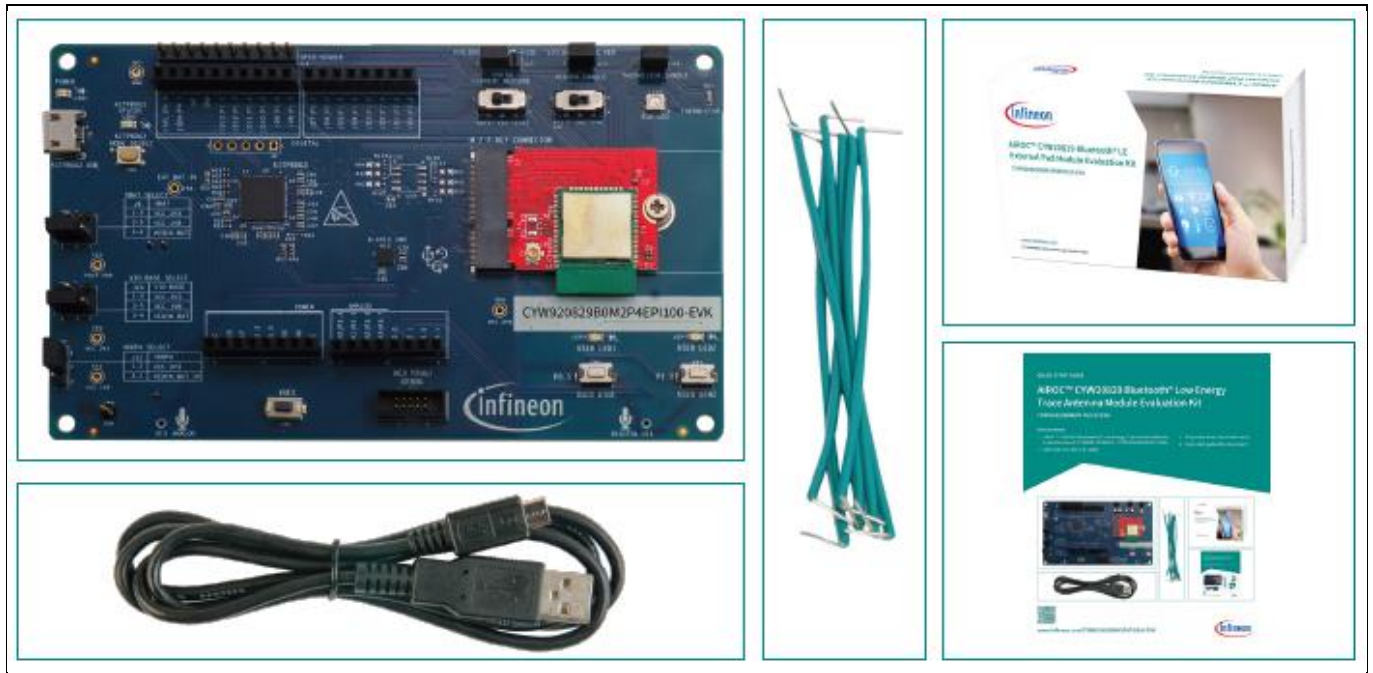

Figure 1 CYW920829M2EVK-02 kit contents

Contact the nearest Infineon sales office for assistance for any missing part in the kit contents: www.infineon.com/support.

1.2 CYW920829B0M2P4XXI100-EVK details

CYW920829B0M2P4XXI100-EVK with the following features:

1. CYW20829 carrier module with onboard Trace antenna or External Pad
2. Expansion headers compatible with Arduino shields
3. Supports 3.3 V, coin-cell (3 V), and 1.8 V operation of the CYW920829B0M2P4XXI100-EVK device
4. Reset button (black), User button1 (white), and User button2 (white)
5. Onboard Micro-USB connector (J5) for programming and debugging purposes

Follow these steps before connecting the board and verify the driver installation:

1. Ensure that all the jumpers are in the default configuration as shown in [Table 2](#) to [Table 7](#) so that the UART is selected and displays embedded application trace messages. [Figure 2](#) shows the default jumper locations.
2. Default jumper location on EVK is given in [Table 1](#).

Table 1 Default jumper configurations on the EVK

Jumper ref des	Jumper description	Default state
J9	VBAT voltage selection	1-3
J10	VIO_BASE voltage selection	1-3
J12	VDDPA voltage selection	1-2
J17	VIO_BASE / eFuse(2V5) voltage selection	1-2
J13	Peripheral voltage enable	1-2
J14	Thermistor enable	1-2

Introduction

3. Connect the USB connector (J5) of the EVK to the development PC with the provided USB cable. The USB UART driver loads automatically. If the EVK is not detected as a USB device, reinstall the USB UART driver in the ModusToolbox™ installation directory.

For Windows and macOS: <install>\tools_3.0\driver_media\dpinst.

For Linux: <install>\tools_3.0\driver_media\install_driver\dpinst.



Figure 2 CYW920829B0M2P4XXI100-EVK

Figure 3 highlights the LEDs provided on CYW920829B0M2P4XXI100-EVK:

- LED1 (yellow) indicates that VBAT power is ON
- LED2 (yellow) indicates KitProg3 status
- LED3 (red) and LED4 (orange) are generic user LED controlled by GPIOs. A label on the back of the kit provides the pin mapping
- LED5 is RGB LED which is controlled with three GPIOs

Introduction

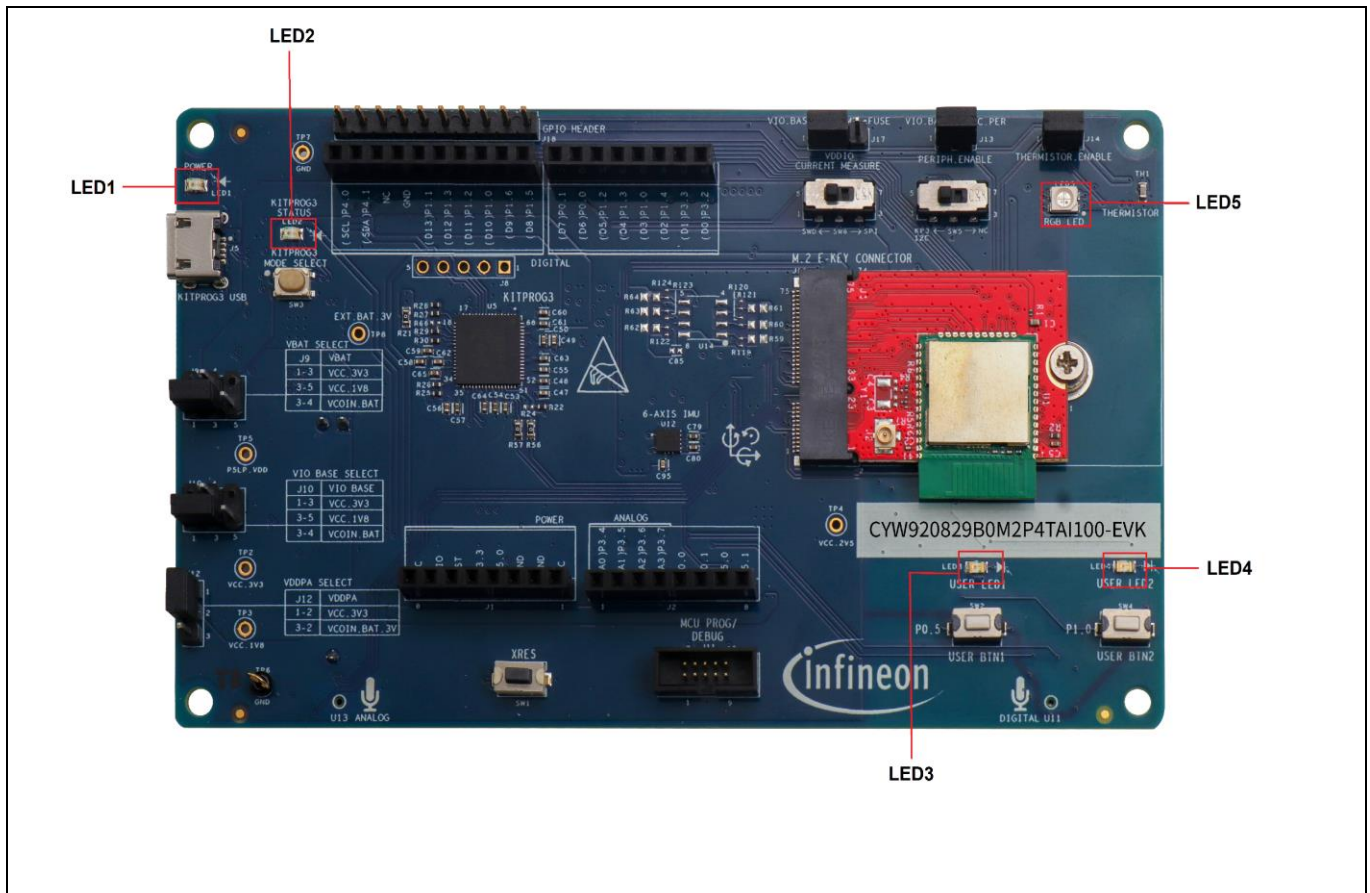

Figure 3 CYW920829B0M2P4XXI100-EVK LEDs

1.3 ModusToolbox™

ModusToolbox™ is a free software development ecosystem that includes the Eclipse IDE for ModusToolbox™, AIROC™ BTSTACK, Bluetooth® SDK, and the PSoC™ 6 SDK to develop applications for the Infineon IoT products. The Eclipse IDE for ModusToolbox™ is a multi-platform, integrated development environment (IDE) used to create new applications, update application code, change middleware settings, and program or debug applications.

ModusToolbox™ is used to enable and configure device resources and middleware libraries, write C source code, and program and debug the device. The build system infrastructure includes the new project creation wizard that can run independently of the Eclipse IDE, the make infrastructure, and other tools. This means compiler, RTOS, and ecosystem is selected without compromising the usability or access to our industry-leading CAPSENSE™ (Human-Machine Interface), AIROC™ Wi-Fi and Bluetooth®, security, and various other features.

The Infineon’s **AIROC™ BTSTACK** is a software implementation of the Bluetooth® core 5.4 host protocol stack. The stack is hosted as a library on Infineon’s GitHub. The stack library includes both Bluetooth® BR/EDR and Bluetooth® Low Energy hosts and provides APIs for them. The application can choose to use Bluetooth® Low Energy or both BR/EDR + LE. The stack is available for different Arm® cores, such as CM4 and CM33, and can be used with three toolchains Arm®, GCC, and IAR.

For more details on ModusToolbox™ installation and usage, see the [ModusToolbox™ user guide](#).

Introduction

1.3.1 Select a new workspace

At launch, the ModusToolbox™ presents a dialog to choose a directory for use as the workspace directory. The workspace directory stores the workspace preferences and development artifacts, such as device configuration and application source code.

To choose an existing empty directory, click the **Browse** button, as [Figure 4](#) shows. Alternatively, a directory name to be used as the workspace directory is added along with the complete path, and ModusToolbox™ creates the directory.

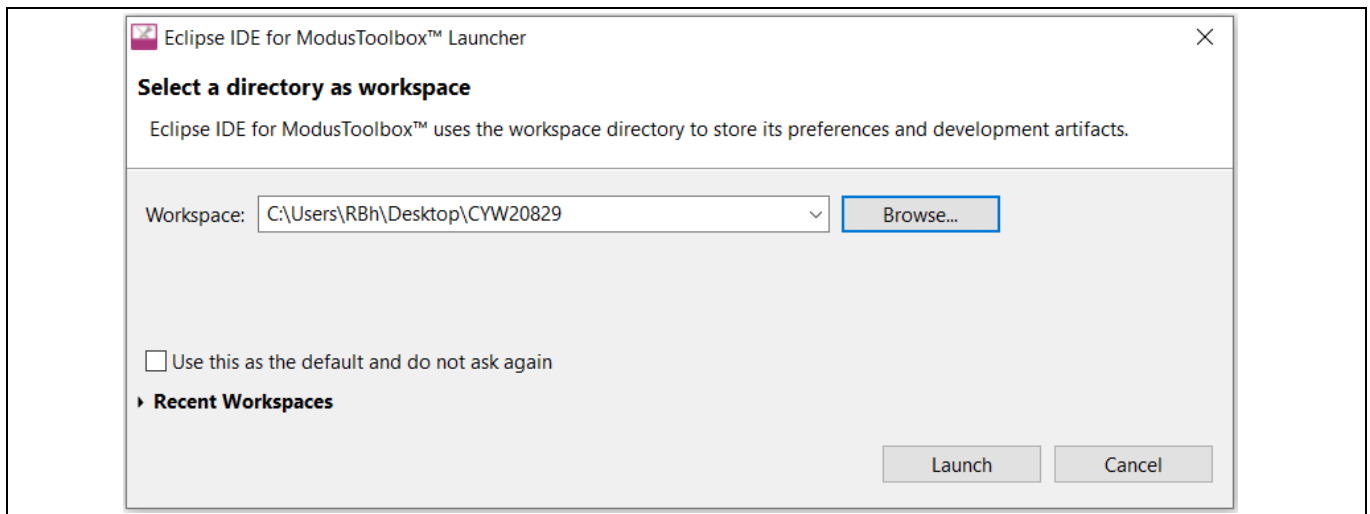

Figure 4 Select a directory as workspace

1.3.2 Create a new ModusToolbox™ application

Click **New Application** in the Start group of the Quick Panel. Alternatively, choose **File > New > ModusToolbox™ Application** ([Figure 5](#)).

The Eclipse IDE for ModusToolbox™ application window appears.

Introduction

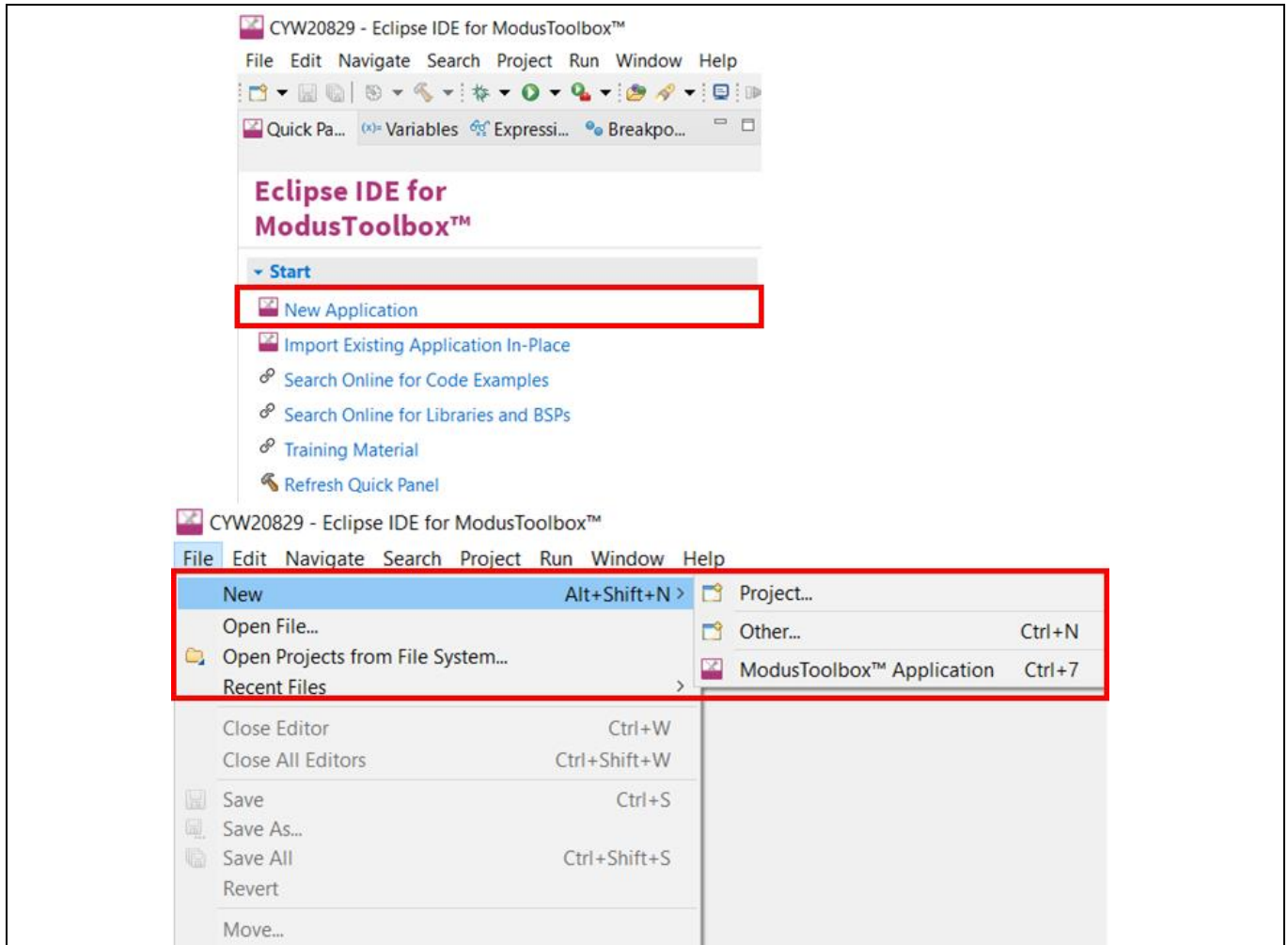

Figure 5 Create a new Modus Toolbox™ application

1.3.3 Select CYW20829 MCU-based target hardware

The Modus Toolbox™ presents the list of Infineon kits to start the application development. In this case, developing an application on the CYW20829 Evaluation Kit uses the CYW20829 device. Select **CYW920829M2EVK-02** and click **Next** (Figure 6).

Note:

- All the Code Examples are available for CYW920829B0M2P4XXI100-EVK **is same as CYW920829M2EVK-02 BSP.**
- There is no separate BSP for CYW920829B0M2P4XXI100-EVK, Silicon EVK BSP is used for Module EVKs.

Introduction

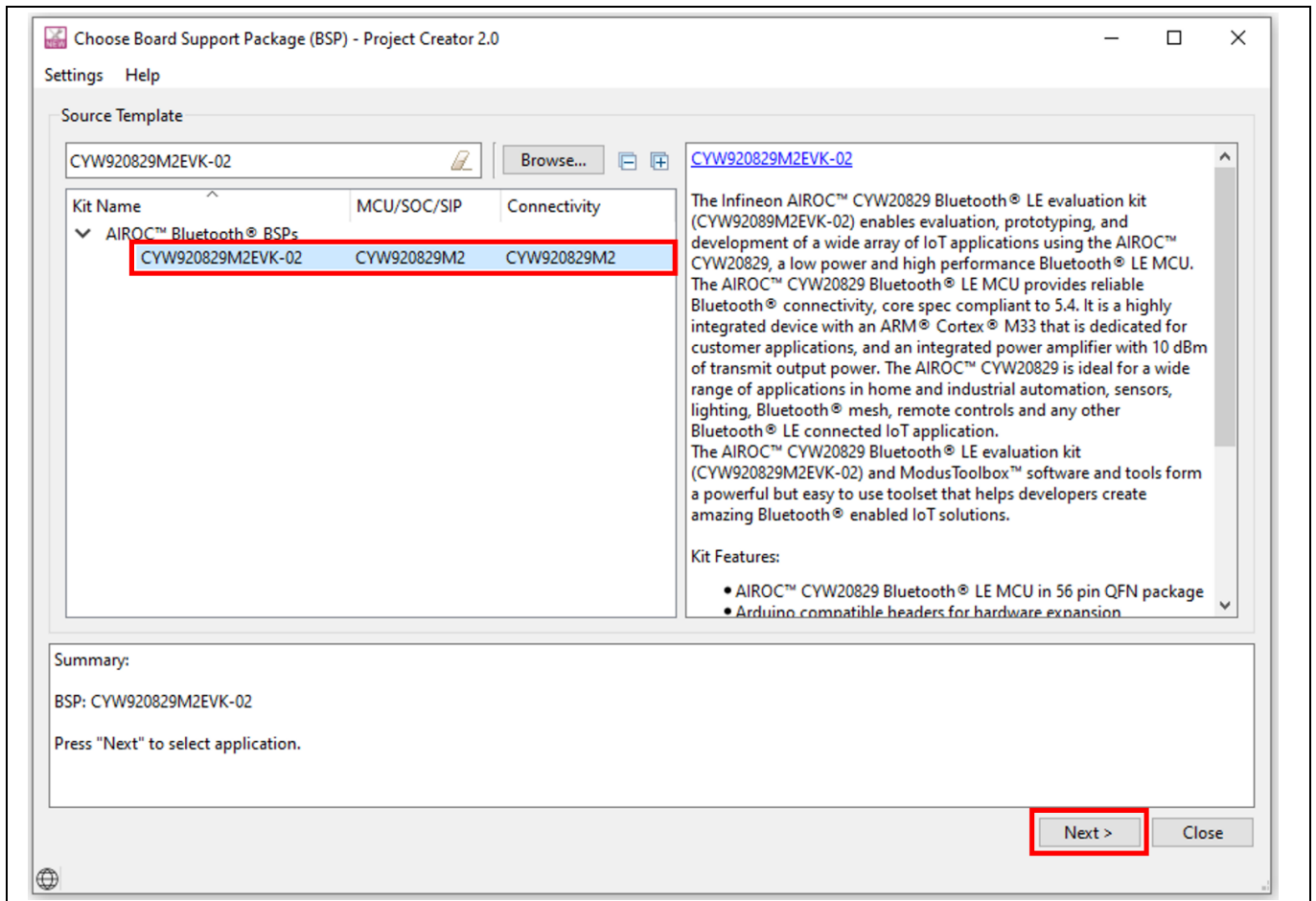

Figure 6 Choose target hardware

1.3.4 ModusToolbox™ code examples

ModusToolbox™ includes many code examples. Many of these code examples are compatible with this kit. Browse the collection of starter applications during application setup through **File > New > ModusToolbox™ Application** or browse the collection of code examples on Infineon's [GitHub repository](#). See [Figure 7](#) and [Figure 8](#) for more details.

Introduction

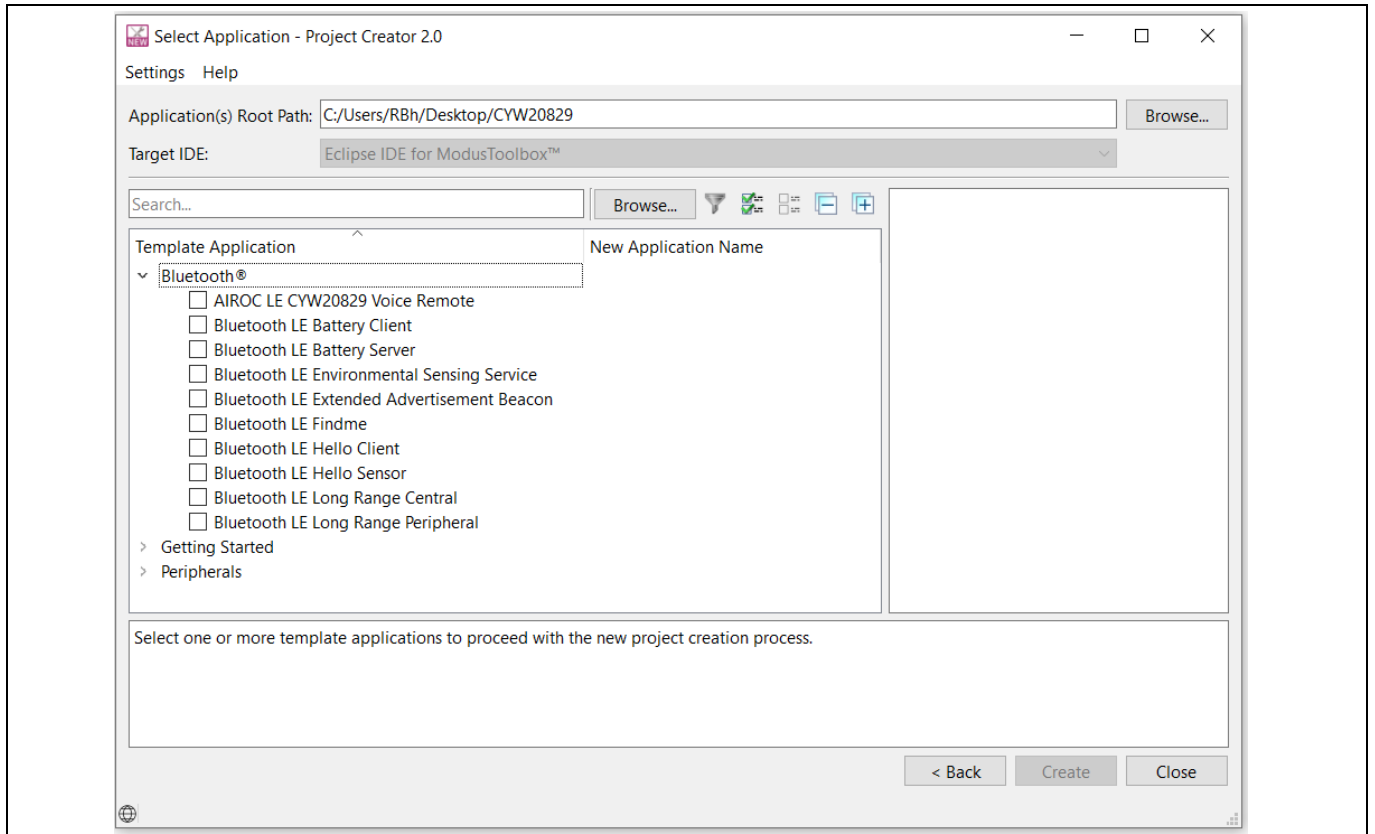

Figure 7 Code examples in ModusToolbox™

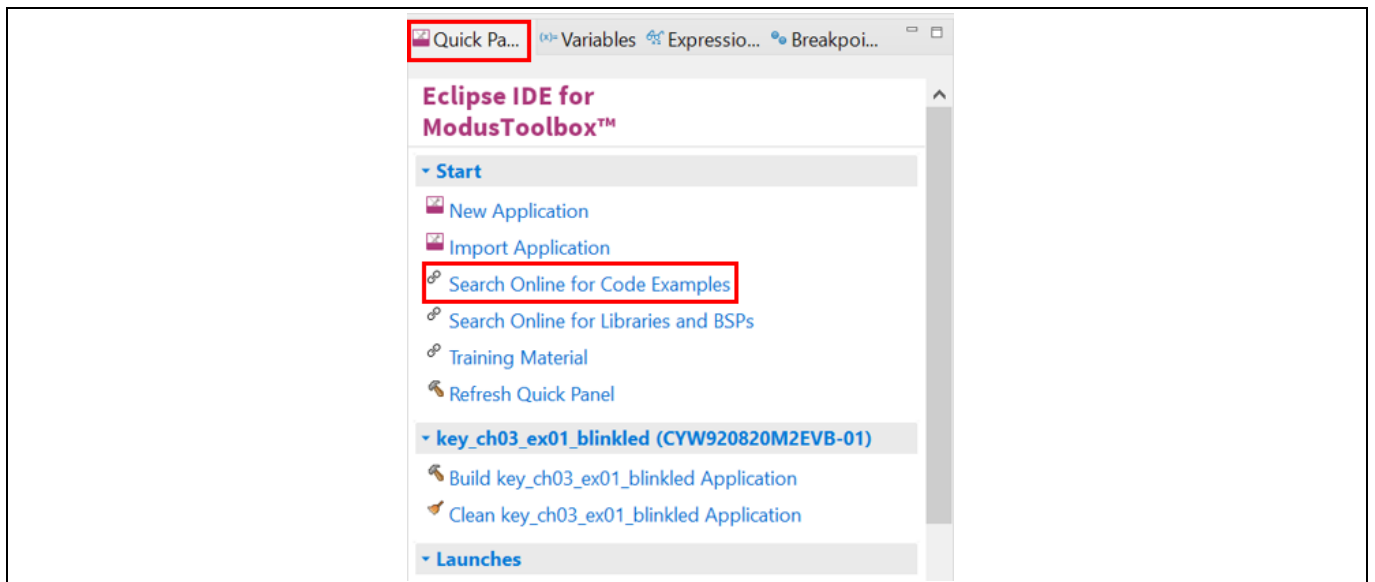

Figure 8 Searching for online code examples in ModusToolbox™

Introduction

1.3.5 Related code examples

The kit code examples are accessed from the [GitHub repository](#). The CYW920829B0M2P4XXI100-EVK is pre-programmed with the Find Me Profile ([CE230297 – Bluetooth® LE Find Me Profile](#) with CYW20829) code example out-of-the-box.

This code example is available in ModusToolbox™ as shown in [Figure 7](#). For the most recent version of the code example, check the GitHub repository. For more information, see the code example [CE230297](#) and for the functionality, design, and implementation of the code example, see the Readme in the same folder as that of the code example.

To import the most recent version of the GitHub code examples into ModusToolbox™, see the ModusToolbox™ user guide document (**Help > ModusToolbox™ Documentation > User guide**).

1.3.6 ModusToolbox™ help

Launch ModusToolbox™ and navigate to the following items:

- **Quick Start Guide:** Choose **Help > Eclipse IDE for ModusToolbox™ Documentation > Quick Start Guide**. This guide gives you the basics of using ModusToolbox™.
- **ModusToolbox™ General Documentation:** Choose **Help > ModusToolbox™ General Documentation > ModusToolbox™ Documentation Index**. This page provides links to various ModusToolbox™ documents.
- **ModusToolbox™ User Guide:** Choose **Help > Eclipse IDE for ModusToolbox™ Documentation > User Guide**. This is a comprehensive guide for creating, building, and programming ModusToolbox™ applications.

1.4 Getting started

This user guide helps to find the details of the CYW920829B0M2P4XXI100-EVK kit:

- The [Kit operation](#) chapter describes the operation of the kit and the utility of its various features.
- The [Hardware](#) chapter describes the design details of the CYW920829B0M2P4XXI100-EVK hardware blocks.
- To create a project using ModusToolbox™, see [AN238254-Getting Started with AIROC™ CYW20829 Bluetooth® LE on ModusToolbox™](#)

1.5 IoT resources and technical support

To select the right IoT device for the design, Infineon provides a wide range of product documentation at www.infineon.com/products/wireless-connectivity. Also, a professional community at community.infineon.com supplies developers with the latest software and tools to solve common evaluation and integration problems while interacting directly with both Infineon engineers and experienced peers.

Kit operation

2 Kit operation

This section provides detailed instructions to setup the Infineon CYW920829B0M2P4XXI100-EVK with Infineon ModusToolbox™ for Bluetooth® Low Energy applications.

This chapter introduces CYW920829B0M2P4XXI100-EVK and the features that are used as part of the kit’s operation. This chapter also discusses the features such as Bluetooth® connectivity, programming/debugging, and USB-UART bridge device that can be used to communicate with the CYW20829 device on this EVK.

2.1 Theory of operation

CYW920829B0M2P4XXI100-EVK is built around CYW20829 device. [Figure 9](#) shows the block diagram of the CYW20829 device. See the device [datasheet](#) for more details on device features.

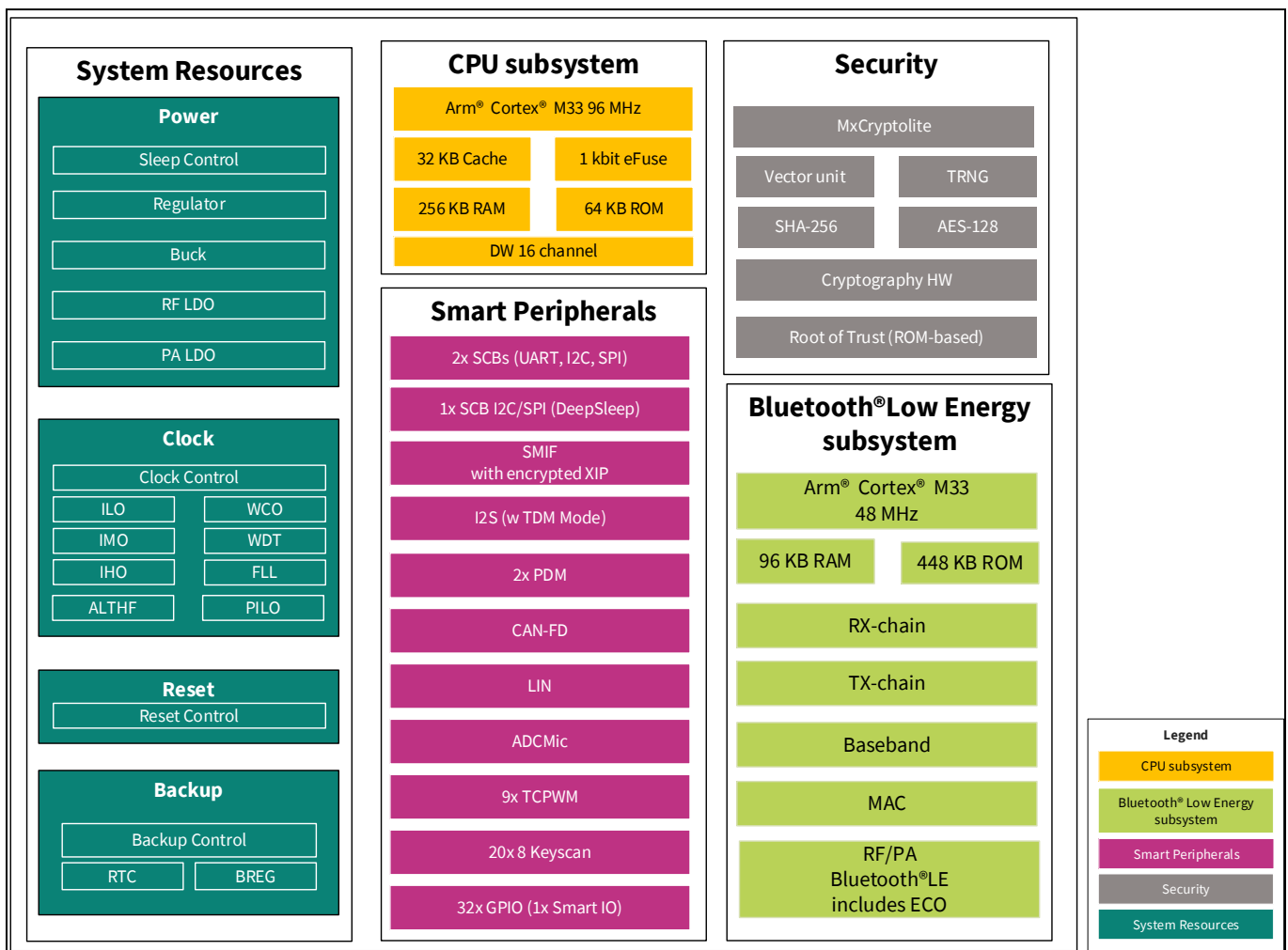

Figure 9 Block diagram of CYW20829

[Figure 10](#) illustrates the block diagram of CYW920829B0M2P4XXI100-EVK. This board contains a CYW20829 Bluetooth® SoC and a USB-Serial interface/programmer. The kit features Arduino form-factor-compatible headers, which enable Arduino shields to be plugged in, extending the EVK’s capabilities. It also features two user switches, one reset switch, two user LEDs, a thermistor, IMU, AMIC, DMIC, and multiple power supply options.

Kit operation

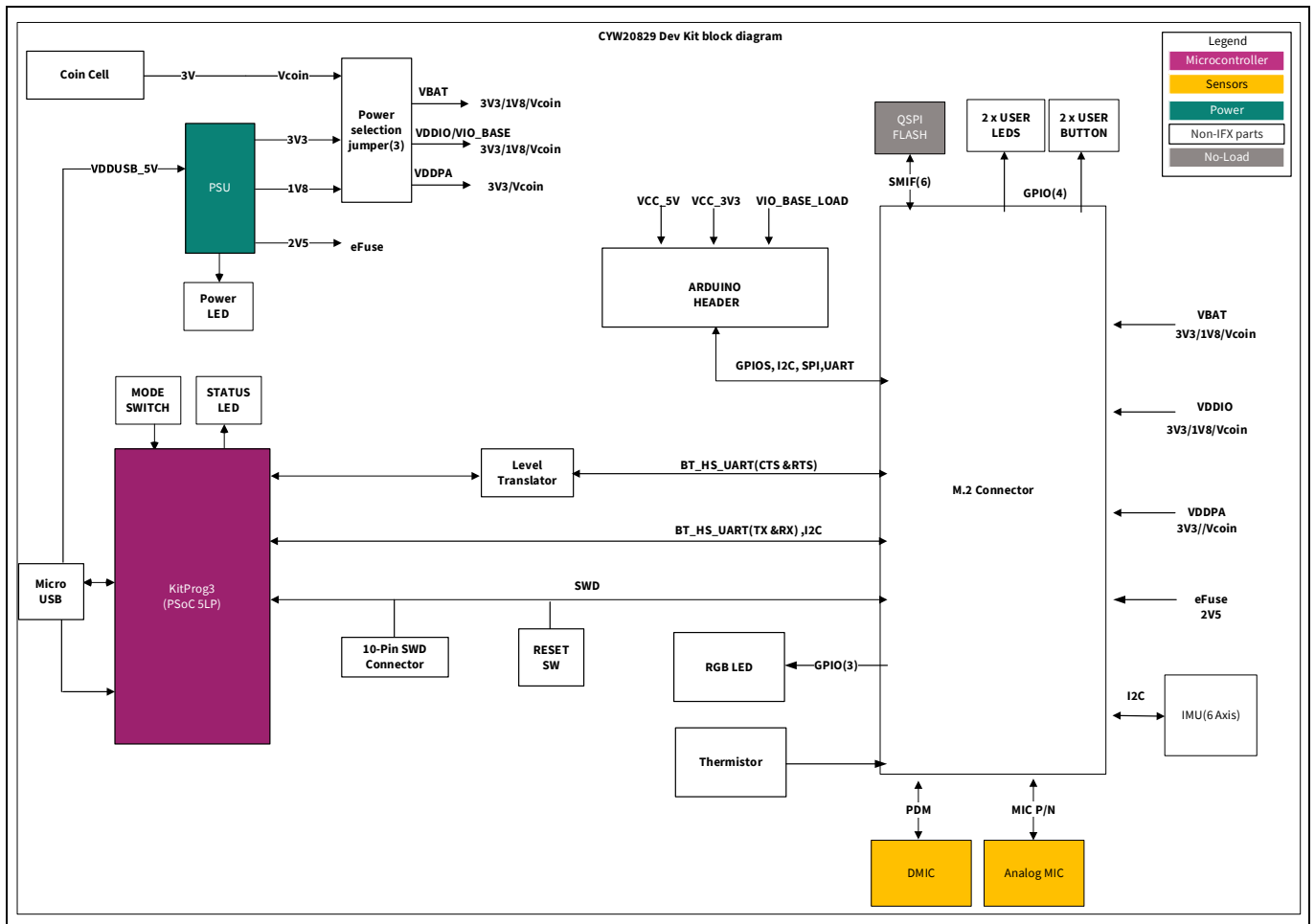

Figure 10 Block diagram of CYW920829B0M2P4XXI100-EVK baseboard

Figure 11 and Figure 12 show the markup of the CYW920829B0M2P4XXI100-EVK and the list below for a description of the numbered items.

AIROC™ CYW20829: CYW920829B0M2P4XXI100-EVK Module

Evaluation Kit user guide



Kit operation

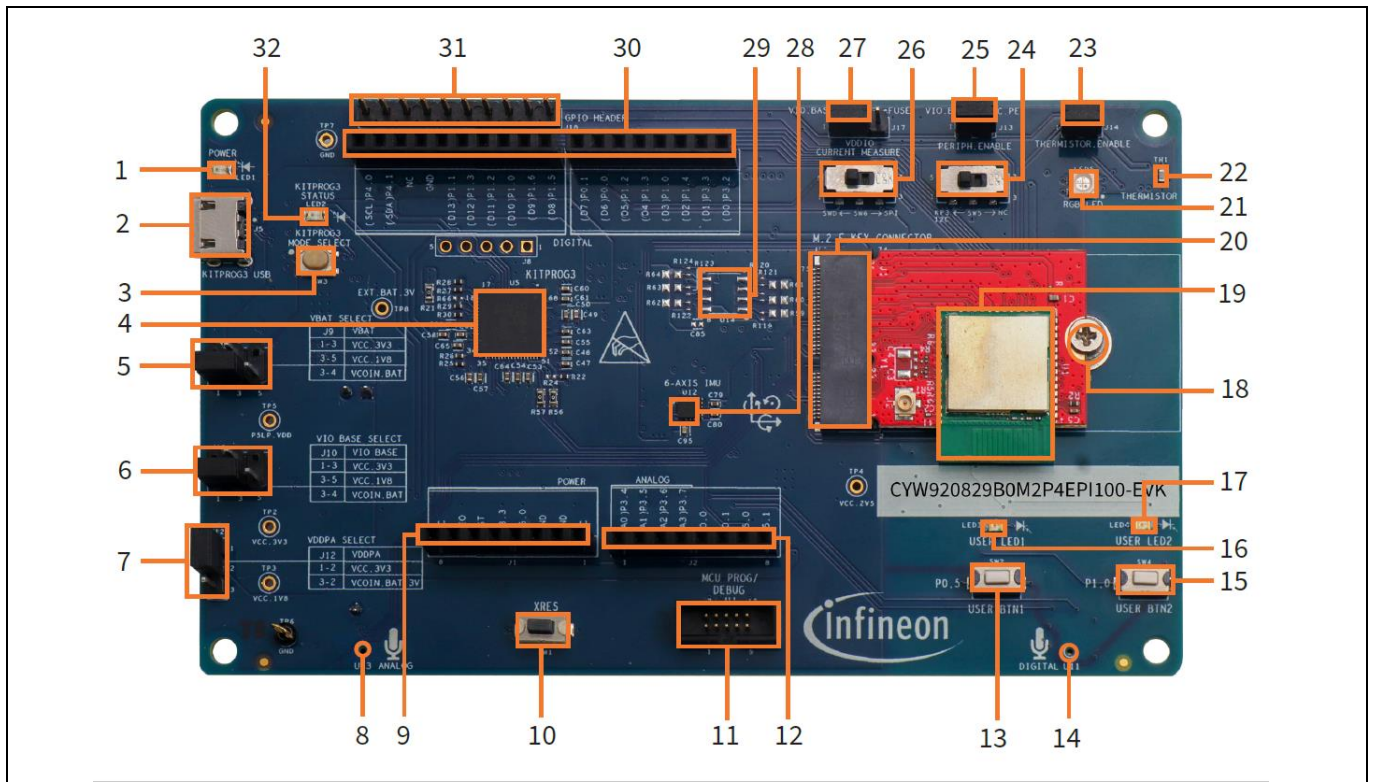

Figure 11 CYW920829B0M2P4XXI100-EVK (top view)

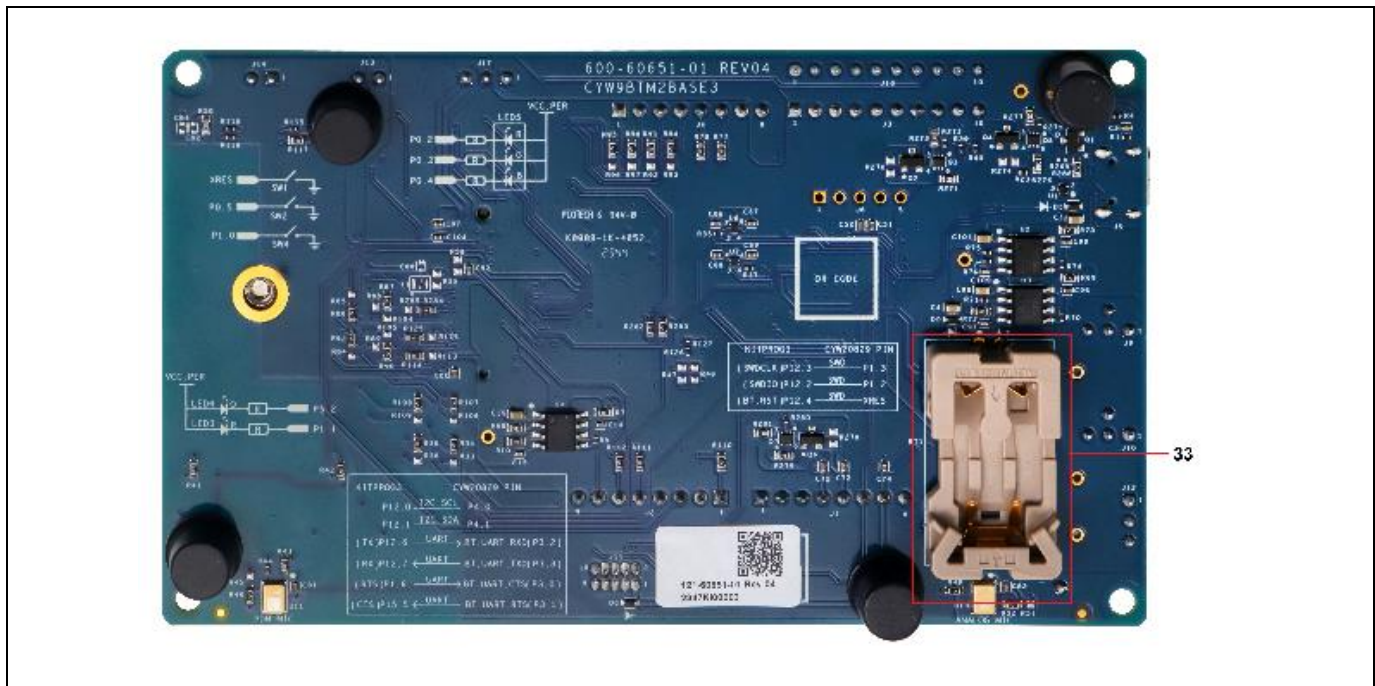

Figure 12 CYW920829B0M2P4XXI100-EVK (bottom view)

Kit operation

1. **Power indicator LED (LED1):** This LED is used to indicate the status of power supplied to the board.
2. **USB connector (J5):** J5 is a Micro-B USB female connector for connecting the kit to the PC using the provided USB cable. It is used for programming and USB-UART communication.
3. **KitProg3 Programming mode selection button (SW3):** by default, the kit supports CMSIS-DAP BULK mode. The button connects the PSoC™ 5LP pin to the ground when pressed. For more details, see the [KitProg3 user guide](#).

Note: Dual UART mode is not supported because there is no hardware connection between KitProg3 and M.2 interface.

4. **KitProg3 (PSoC™ 5LP) programmer and debugger (CY8C5868LTI-LP039, U5):** The PSoC™ 5LP (CY8C5868LTI-LP039) serving as KitProg3, is a multi-functional system, that includes a Serial Wire Debug (SWD) programmer, debugger, USB-I2C bridge, and USB-to-UART bridge. For more details, see the [KitProg3 user guide](#).
5. **VDDPA select jumper (J12):** This jumper is used to select the VDDPA (power amplifier supply) power source. The possible selections are 3.3 V or VCOIN (3 V) which is the coin-cell power supply on the bottom side of the board.
6. **VIO_BASE select jumper (J10):** This jumper is used to select the VIO_BASE power source. Possible selections are 3.3 V, 1.8 V, or VCOIN (3 V), which is the coin-cell power supply on the bottom-side of the board.
7. **VBAT select jumper (J9):** This jumper is used to select the VPA_BT (core power supply) power source. The possible selections are 3.3 V, 1.8 V, or VCOIN (3 V) which is the coin-cell power supply on the bottom-side of the board.
8. **Analog mic (U13):** It can be used to configure the kit as a voice remote.
9. **Arduino-compatible header (J1):** The Arduino-compatible I/O header brings out power and reference voltage pins from the base board to interface with Arduino shields.
10. **Reset button (SW1, XRES):** This button can be used to reset the device.
11. **Debug header (J13):** J13 is a 10-pin interface header that can be used to connect an external programmer/debugger via SWD.

Note: Use J13 only to connect a programmer/debugger. A voltage mismatch occurs if something else is connected to J13 to communicate with KitProg3.

12. **Arduino-compatible header (J2):** The Arduino-compatible I/O header brings out pins from CYW20829 to interface with Arduino shields.
13. **User button1 (SW2):** This button can be used to provide input to the CYW20829 device. Note that the button connects the CYW20829 pin to the ground when pressed; therefore, the CYW20829 pin must be configured as a digital input with a resistive pull-up for detecting the button press.
14. **Digital mic (U11):** The digital microphone ASIC contains an extremely low-noise preamplifier and a high-performance sigma-delta ADC. It can be used to configure the kit as a voice remote.
15. **User button2 (SW4):** This button can be used to provide input to the CYW20829 device. Note that the button connects the CYW20829 pin to the ground when pressed; therefore, the CYW20829 pin must be configured as a digital input with a resistive pull-up for detecting the button press.
16. **User LED1 (LED3):** These onboard LEDs can be controlled by the CYW20829 device. The LEDs are ACTIVE LOW; therefore, these pins must be driven low to turn ON the LEDs.
17. **User LED2 (LED4):** These onboard LEDs can be controlled by the CYW20829 device. The LEDs are ACTIVE LOW; therefore, these pins must be driven LOW to turn ON the LEDs.
18. **M.2 Stand Off (MT1):** Stand to connect M.2 card.

Kit operation

19. **CYW20829 (U1)**: The Bluetooth® LE 5.4 qualified Trace antenna module/ external pad module is the heart of this evaluation kit.
20. **M.2 E key connector (J16)**: This is used to interface Infineon custom Bluetooth® LE M.2 boards to this kit.
21. **RGB LED (LED5)**: These onboard LEDs can be controlled by the CYW20829 device. The LEDs are ACTIVE LOW; therefore, these pins must be driven to the ground to turn ON the LEDs.
22. **Thermistor (TH1)**: The onboard thermistor is an NTC analog thermistor that can be used to measure temperature.
23. **Thermistor enable jumper (J14)**: This jumper can be used to connect or disconnect the onboard thermistor from the CYW20829 device.
24. **KitProg3 I2C Interface (SW5)**: For COIN CELL OPERATION, place the SW5 in POS2 to isolate the Leakage path into KP3 section
25. **Peripheral enable (J13)**: The jumper allows the user to connect and disconnect the VDDIO supply to onboard peripheral devices such as the IMU, thermistor, analog mic, and real-time clock by disabling VDDP.
26. **SWD/SPI selection (SW6)**: For COIN CELL OPERATION, place the SW6 in POS2 to isolate the Leakage path into KP3 section
27. **VDDIO current measurement jumper (J17)**: This jumper is used to power the carrier module. Remove this jumper and connect an ammeter to the two pins to measure the current the carrier module uses.
28. **6-axis IMU(U12)**: This is an I2C-based 6-axis IMU sensor.
29. **1-MB serial flash (U14)**: This is the 8 Mb QSPI flash used for application purposes (no-load by default).
30. **Arduino-compatible header (J4 and J3)**: The Arduino-compatible I/O header brings out pins from CYW20829 to interface with Arduino shields.
31. **Digital I/O headers (J18)**: The extended GPIO headers for extending the additional GPIOs from the CYW20829 device.
32. **KitProg3 status indication LED (LED2)**: This yellow LED indicates the status of KitProg3.
33. **Coin cell holder (BT1)**: This is a coin cell battery holder located on the bottom side of the development kit. If the EVK needs to use the power supplied from the coin cell, then set the VBAT, VIO_BASE, and VDDPA select headers to VCOIN.

2.2 Jumpers

Table 2 to Table 7 list the jumper settings on the CYW920829M2EVK-02.

Table 2 Jumper J9 pin configurations

Jumper J9 (VBAT selection)	Default state	Connection on CYW20829	Description
1 and 3	Shorted	VBAT	Short these pins to supply 3.3 V to VBAT of the CYW20829 device
3 and 5	Open		Short these pins to supply 1.8 V to VBAT of the CYW20829 device
3 and 4	Open		Short these pins to supply the VBAT of the CYW20829 device from the coin cell supply (VCOIN)

Kit operation

Table 3 Jumper J10 pin configurations

Jumper J10 (VIO_BASE selection)	Default state	Connection on CYW20829	Description
1 and 3	Shorted	VDDIO	Short these pins to supply 3.3 V to VIO_BASE of the CYW20829 device, as well as all peripherals and sensors
3 and 5	Open		Short these pins to supply 1.8 V to VIO_BASE of the CYW20829 device, as well as all peripherals and sensors
3 and 4	Open		Short these pins to supply VIO_BASE of the CYW20829 device, as well as all peripherals and sensors from the coin cell supply (VCOIN)

Table 4 Jumper J12 pin configurations

Jumper J12 (VDDPA selection)	Default state	Connection on CYW20829	Description
1 and 2	Shorted	VDDPA	Short these pins to supply 3.3 V to VDDPA of the CYW20829 device. Also, use this jumper to measure the current consumption of VDDPA when using a 3.3 V supply.
2 and 3	Open		Short these pins to supply VCOIN to VDDPA of the CYW20829 device. In addition, use this jumper to measure the current consumption of VDDPA when using the coin cell supply (VCOIN).

Table 5 Jumper J14 pin configuration

Jumper J14 (Thermistor connect/disconnect)	Default state	Connection on CYW20829	Description
1 and 2	Shorted	P3.4	Short this jumper to connect the onboard thermistor to CYW20829. If user need to isolate Thermistor to use P3.4 as Analog IO. This jumper to be kept open.

Kit operation

Table 6 Jumper J17 pin configuration

Jumper J17 (VDDIO current measurement)	Default state	Connection on CYW20829	Description
1 and 2	Shorted	VDDIO_1, VDDIO_2, VDDIO_A, VDDA	Short this jumper to supply power to the I/O domain (VDDIO) of CYW20829 with VIO_BASE (3V3, 1V8 or VCOIN). In addition, use this jumper to measure the current consumption of the I/O domain.
2 and 3	Open	VDDIO_1, VDDIO_2, VDDIO_A, VDDA	Short this jumper to supply power to the I/O domain (VDDIO) of CYW20829 with 2V5 (eFuse) programming use case.

Table 7 Jumper J13 pin configuration

Jumper J13 (Peripheral enable)	Default state	Connection on CYW20829	Description
1 and 2	Shorted	NA	Allows power to onboard peripherals such as IMU, flash, DMIC, AMIC, Thermistor, and LEDs

2.3 Buttons and switches

Table 8 Button functionality

Buttons	Pressed state	Connection on CYW20829	Description
SW1	GND	BT_RST_N	Active-LOW Reset button (black)
SW2	GND	P0.5	User application button (white)
SW3	GND	NA	Switch allows you to change the KP3 mode
SW4	GND	P1.0	User application button (white)

Switch	Switch Position	Connection on CYW20829 EVK	Description
SW5	POS1	P4.0 & P4.1	I2C_SDA and I2C_CLK connected to KP3
SW6	POS2	NC	Used to isolate the Leakage path through KP3 during coin cell operation

2.4 Arduino-compatible headers

J3, J4, J1, and J2 are Arduino-compatible headers.

Table 9 Header J3 pin configuration

Header J3	Arduino pin	Connection on CYW20829	Description
1	D8	P1.5	GPIO
2	D9	P1.6	GPIO
3	D10	P1.0	GPIO

Kit operation

Header J3	Arduino pin	Connection on CYW20829	Description
4	D11	P1.2	GPIO
5	D12	P1.3	GPIO
6	D13	P1.1	USER_LED1
7	GND	GND	Ground
8	NC	NC	NC
9	SDA	P4.1	I2C SDA
10	SCL	P4.0	I2C SCL

Table 10 Header J4 pin configuration

Header J4	Arduino-compatible pin	Connection on CYW20829	Description
1	D0	P3.2	GPIO
2	D1	P3.3	GPIO
3	D2	P1.4	GPIO
4	D3	P1.0	GPIO
5	D4	P1.3	GPIO
6	D5	P1.2	GPIO
7	D6	P0.0	GPIO
8	D7	P0.1	GPIO

Table 11 Header J1 pin configuration

Header J1	Arduino-compatible pin	Connection on CYW20829	Description
1	NC	NC	NC
2	GND	GND	Ground
3	GND	GND	Ground
4	5V	VDD5V	5 V supply output to the Arduino shield
5	3V3	VDD3P3	3.3 V supply output to the Arduino shield
6	RST_N	XRES	Arduino reset
7	VIO_BASE_LOAD	VDDIO	I/O reference pin used by shields to determine the I/O voltage. Connected to VDDIO on this board. Therefore, IOREF follows 1.8 V or 3.3 V, or V_{COIN} of V_{DDIO}
8	NC	NC	NC

Table 12 Header J2 pin configuration

Kit operation

Header J2	Arduino-compatible pin	Connection on CYW20829	Description
1	A0	P3.4	GPIO
2	A1	P3.5	GPIO
3	A2	P3.6	GPIO
4	A3	P3.7	GPIO
5	A4	P0.0	GPIO
6	A5	P0.1	GPIO
7	A6	P5.0	GPIO
8	A7	P5.1	GPIO

Note: When accessing the Arduino pins, remove the jumpers that interfere with the Arduino-compatible pins, such as thermistor jumper, USER LED, and RGB LED resistors.

Kit operation

2.5 Other headers

J18 is the test header which brings out certain pins of CYW20829 for testing.

Table 13 Header J18 pin description

Header J18	Connection to header pin	Connection on CYW20829	Description
1	USER LED1	P1.1	This onboard LED can be controlled by the CYW20829 device
2	USER LED2	P5.2	This onboard LED can be controlled by the CYW20829 device
3	USER BTN1	P0.5	This button can be used to provide input to the CYW20829 device
4	GPIO1	P0.2	GPIO
5	GPIO2	P0.3	GPIO
6	GPIO3	P0.4	GPIO
7	GPIO4	P3.0	GPIO
8	GPIO5	P3.1	GPIO
9	NC	NC	No connection
10	GND	GND	Ground

J11 is a 10-pin programmer/debugger header to debug CYW920829M2EVK-02 using SWD.

Table 14 Header J11 pin description

Header J11	Connection to header pin	Connection on CYW20829	Description
1	VDDIO	VDDIO	VDDIO reference
2	D5/SWDIO	P1.2	SWD input output
3	GND	GND	Ground
4	D4/SWDCK	P1.3	SWD clock
5	GND	GND	Ground
6	NC	NC	No connect
7	GND	GND	Ground
8	NC	NC	No connect
9	GND	GND	Ground
10	SWD_RST	BT_RST_N	CYW20829 device reset

Note: J11 must be used only to connect a programmer/debugger. If not, a voltage mismatch occurs.

Kit operation

2.6 USB serial interface chip

CY8C5868LTI-LP039 PSoC™ 5LP chip for onboard programming and USB-Serial functionality. It connects to the PC over a USB interface and to the CYW20829 device through the HCI UART and I2C pins.

2.7 Kit power supply

Power the kit with one of the two power sources: USB or coin-cell battery.

Figure 10 shows the USB power is connected to two buck regulators, one regulating the voltage to 1.8 V and the other to 3.3 V. A coin-cell battery can be directly connected without the need for a regulator. See Table 2 through Table 7 to understand the jumper settings for power selection.

2.8 Test points

There are two ground test points for easy connection of probes. The voltage from various power domains can be measured from their respective TPs.

Table 15 Test points available in CYW920829M2EVK-02

Label	Description
TP7, TP6	Test points for ground
TP2	Test point for 3.3 V
TP3	Test point for 1.8 V
TP4	Test point for 2.5 V
TP5	VDD for P5LP
TP8	Test point for 3.0 V from external coin cell battery

2.9 Current measurement

CYW920829B0M2P4XXI100-EVK has one power domain:

- VBAT to power the module

To measure the current consumed by the module domain, connect an ammeter across pin 3, and one of pins 1 or 4 or 5 (depending on the power source) of jumper J9.

Note: VBAT, VDDIO and, VDDPA power rails are shorted in the module.

Kit operation

2.10 SWD debugging

The ModusToolbox™ supports multiple Arm®-JTAG adapters for debugging Bluetooth® products such as CYW20829. Debugging is possible on CYW920829B0M2P4XXI100-EVK through SWD signals. The SWD is a 2-wire interface that uses SWD input output (SWDIO) and serial wire clock (SWDCLK) for debugging the device. In CYW920829B0M2P4XXI100-EVK, P1.2 act as SWDIO, and P1.3 act as SWDCLK. See [Table 14](#) to enable the SWD pins to the debug connector (J11).

Note: The SWD and SPI (MISO and MOSI) interfaces share the same GPIOs and must use one interface at a time.

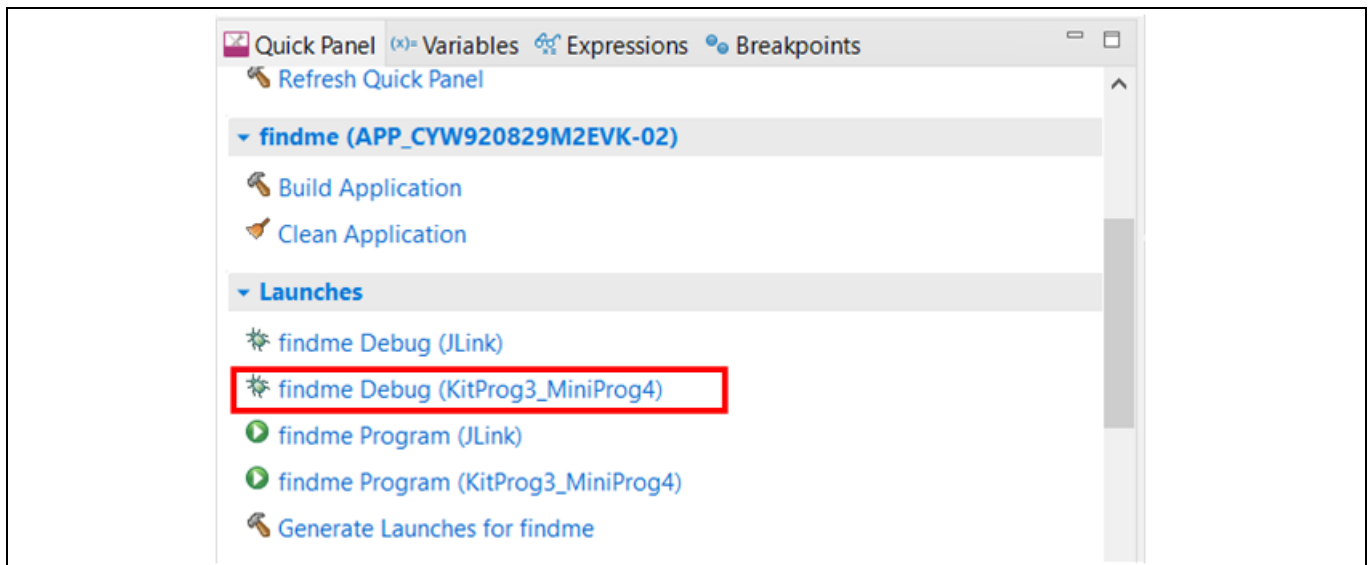

Figure 13 SWD debugging

2.11 Pin configuration

The GPIOs on the CYW20829 device can be multiplexed to various peripherals. For more information on the peripherals that can be routed to the various GPIOs, see the device [datasheet](#).

For this board, the ModusToolbox™ initializes GPIOs to the platform’s default configuration.

3 Hardware

This chapter describes the CYW920829B0M2P4XXI100-EVK hardware and its different blocks, such as reset control, Arduino-compatible headers, and module connectors.

See the [CYW920829B0M2P4TAI100-EVK](#) kit page for schematics for the baseboard and carrier module of trace antenna EVK.

See the [CYW920829B0M2P4EPI100-EVK](#) kit page for schematics for the baseboard and carrier module of trace antenna EVK.

3.1 Carrier module

The baseboard design of the CYW920829B0M2P4XXI100-EVK board is a modular so that various carrier modules can be used with the same baseboard. In this kit, the CYW920829B0M2P4XXI100 carrier M.2 radio card module, which employs the CYW20829 device, is connected to the baseboard through M.2 interface. The carrier module interface is a generic interface used across many devices. See [CYW20829 device I/O mapping](#) for a detailed interface description. The Bluetooth® antenna is etched on the carrier module PCB. UART signals and GPIOs are brought out from module pins to interface with the baseboard.

3.1.1 CYW20829 Module M.2 Board Details

The CYW920829B0M2P4XXI100-EVK board employs the CYW20829 device which is a 56-pin QFN package. This board uses all 26 GPIOs provided by the 56-pin QFN package.

3.1.2 Antenna

A PCB antenna is etched on the carrier module. This antenna is matched to 50 Ω when the CYW920829B0M2P4XXI100-EVK board is placed on a table. [Table 16](#) lists the S11 measurement. See [AN91445 – Antenna design and RF layout guidelines](#) for additional information.

Table 16 Antenna S11 measurement

2402 MHz	2441 MHz	2480 MHz
-9.7 dB	-24.4 dB	-10.8 dB

3.1.3 Crystal

The CYW20829 carrier module has two crystals onboard. A 24-MHz crystal (XTAL) is the main crystal. This XTAL must have an accuracy of +/-20 ppm as defined by the Bluetooth® specification. A 32.768-kHz crystal provides accurate timing during low-power operation. See the [CYW20829 datasheet](#) for crystal requirements.

3.2 Base board

CYW9BTM2BASE3 is a baseboard on which the CYW20829 carrier module is connected. This baseboard provides various sensors to interface with the CYW20829 device.

Hardware

3.2.1 Serial communication between CYW20829 and PSoC™ 5LP KitProg3

The onboard CY8C5868LTI-LP039 PSoC™ 5LP device is a true programmable embedded system-on-chip responsible for two-channel USB-serial conversion on this baseboard. The USB-serial pins of the PSoC™ 5LP device are hard-wired to the HCI UART pins of the CYW20829 device.

Use the mode switch SW3 to switch between various modes of operation of KitProg3. Note that this board supports only CMSIS-DAP BULK mode. This button function is reserved for future use. The status LED (LED5) indicates the current mode of KitProg3.

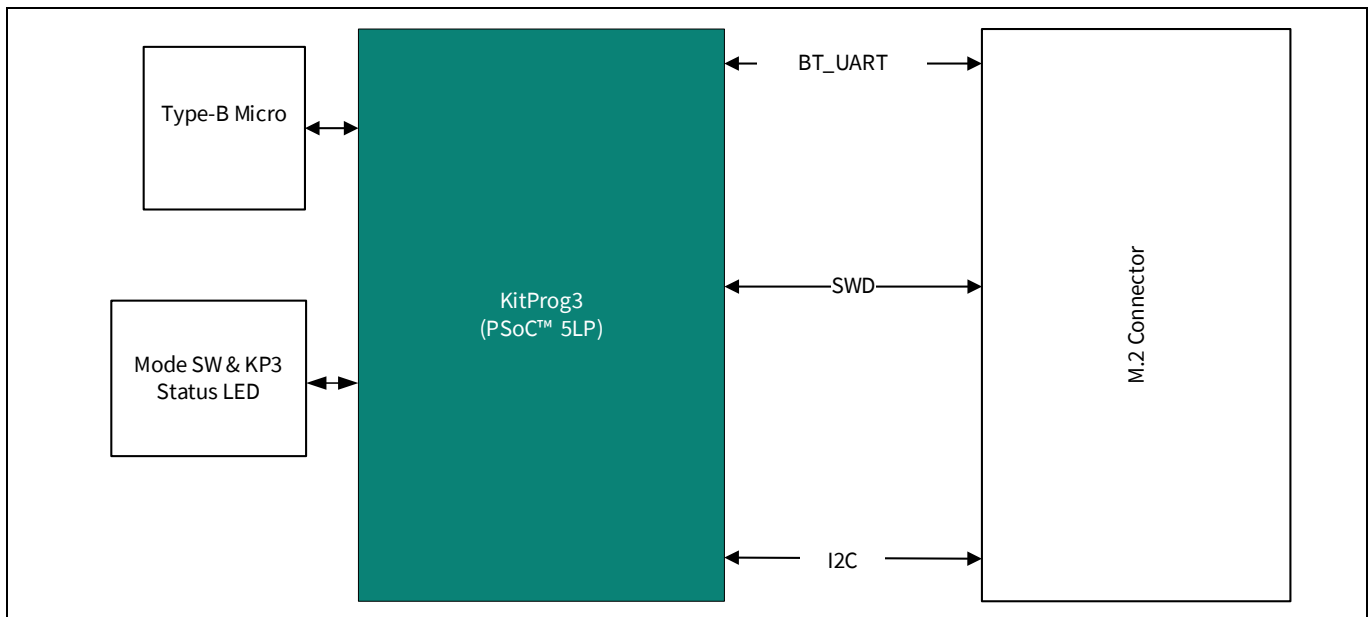

Figure 14 Serial communication between CYW20829 and PSoC™ 5LP KitProg3

3.2.2 Power

The power supply system on this board is versatile, allowing the input supply to come from the following sources:

- 5 V from KitProg3 Micro USB Type-B port
- 3 V from coin-cell

These input source sections can have transient voltage suppression (TVS-diode) to provide ESD protection for the power source at the connector.

The Amber power LED is connected to the VCC_3V3 rail through a current limiting resistor to indicate the board power is ON.

The PSoC™ 5LP (KitProg3) is powered from the KP_VBUS rail with a 0 Ω resistor/jumper in series so that PSoC™ 5LP can be disconnected from the supply rail easily or can be used as a current measurement jumper. On the other hand, KP_VBUS also goes to the Arduino Header (J1) as VCC_ARD_5V0 through a reverse voltage protection circuit.

The kit can have a buck regulator that generates 3V3, 2V5, and 1V8 for VBAT/VDDIO/VDDPA and eFuse voltages of the CYW20829 devices.

The regulated output VCC_1V8 from LDO will go to the peripherals: IMU, thermistor, DMIC, RGB LED, and AMIC through jumper and Arduino-compatible header as VDDIO reference through reverse voltage protection.

Hardware

Figure 15 shows the power architecture of the CYW920829B0M2P4XXI100-EVK.

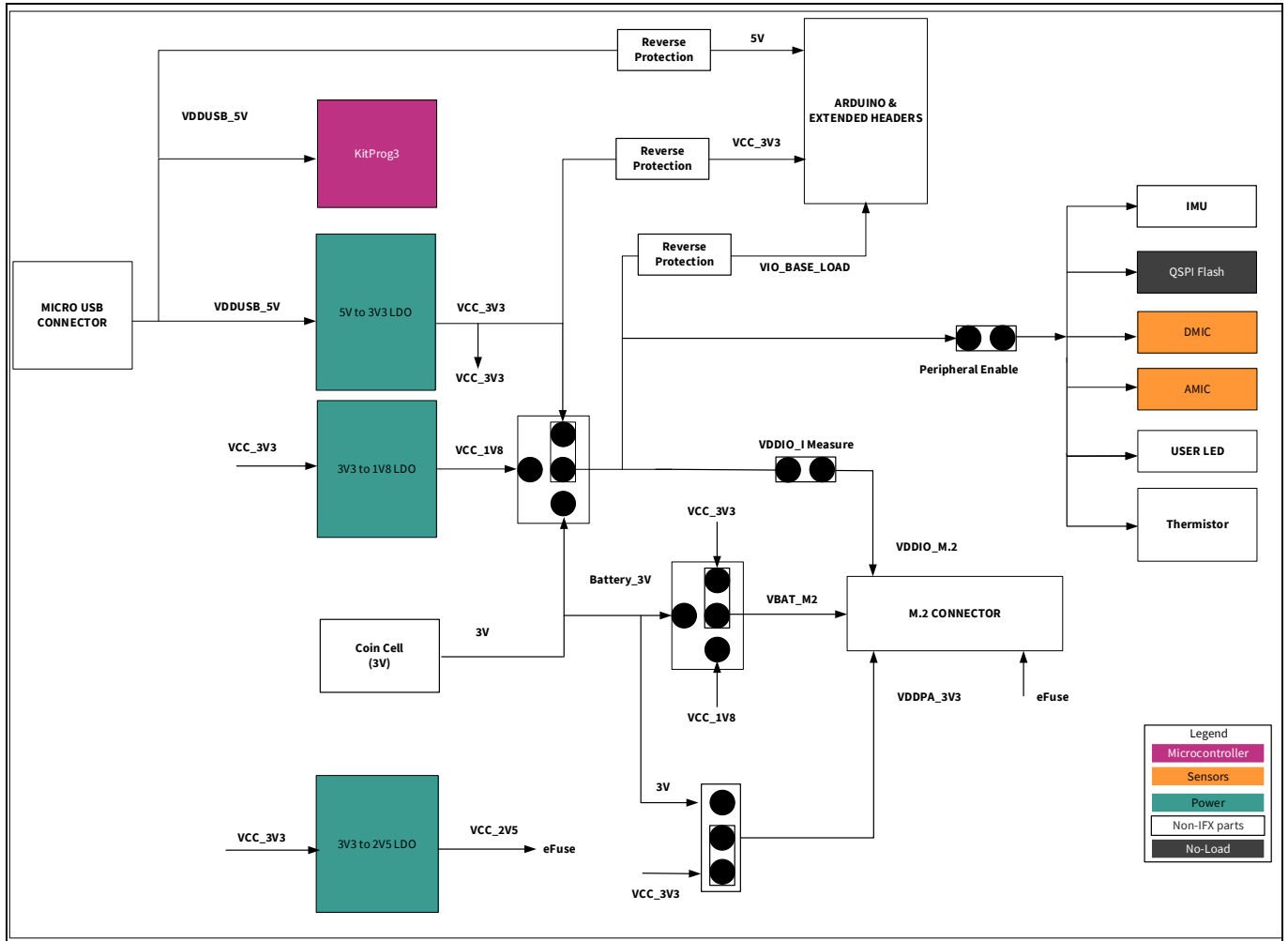

Figure 15 Power architecture of CYW920829B0M2P4XXI100-EVK

Select the power supply options via jumper settings on J9, J10, and J12. See [Table 2](#), and [Table 4](#) for the different jumper settings for these jumpers. Resistors R39 and R40 are pull-up resistors for the I²C lines to the IMU, i.e., SCL and SDA. Short the J13 (Peripheral Enable) for any I²C devices to be connected, because the pull-up voltages for SCL and SDA are supplied from VCC_PER. Power input for the kit is driven through a Micro USB input connector. Generate the required voltages 3V3, 1V8, and 2V5 using the Infineon LDOs.

Hardware

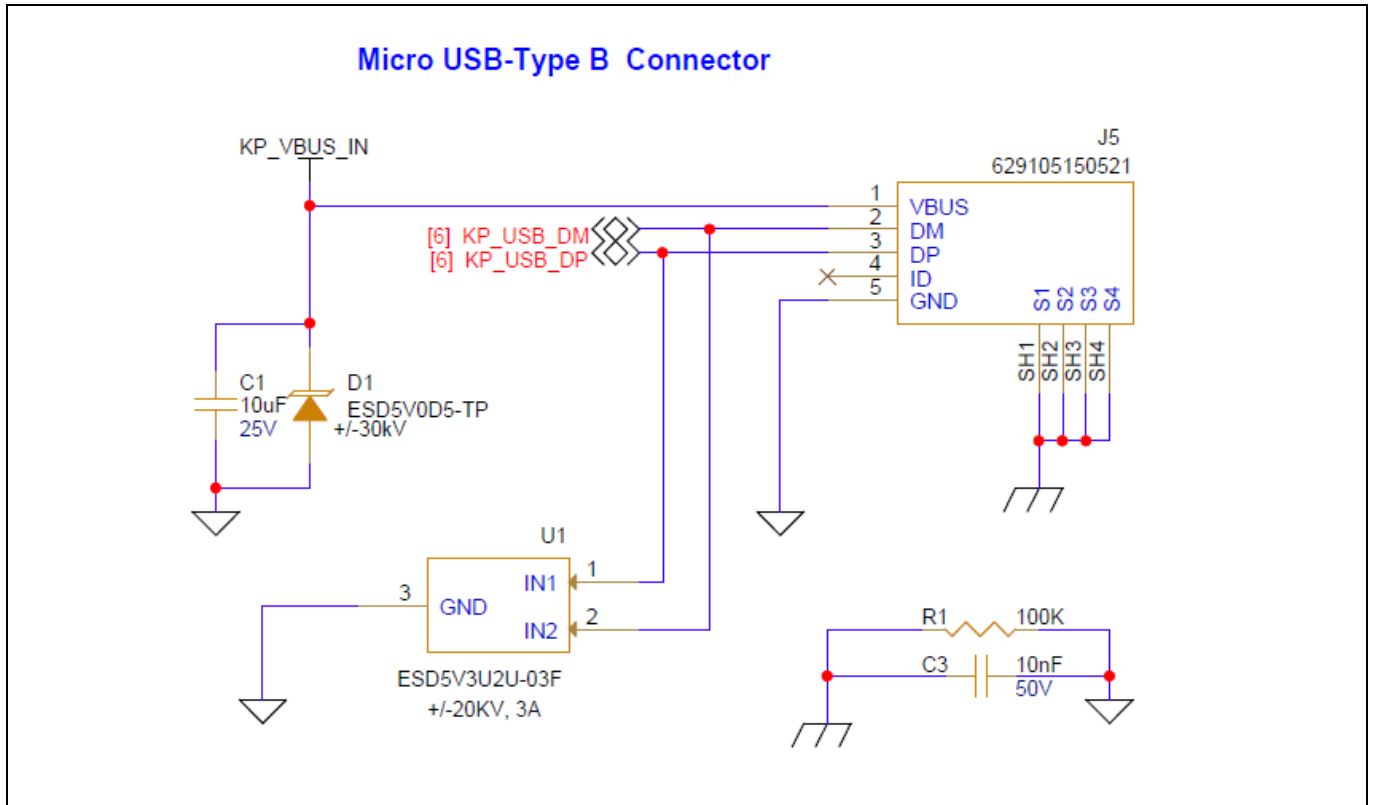

Figure 16 5 V power supply from USB

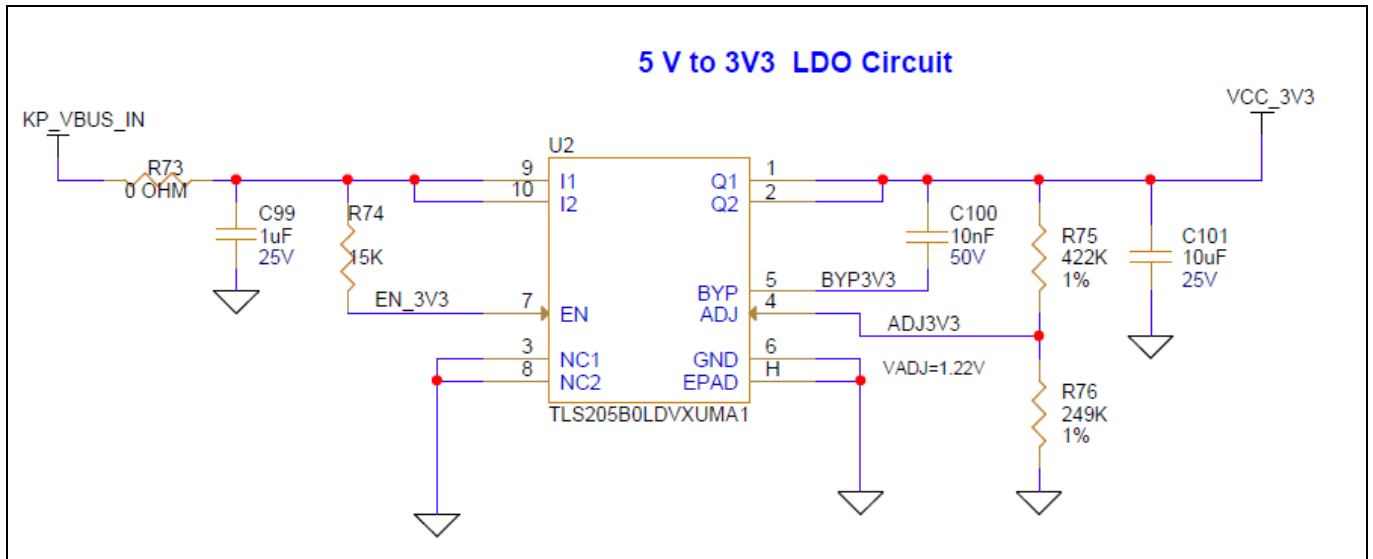

Figure 17 3V3 regulator circuit

Hardware

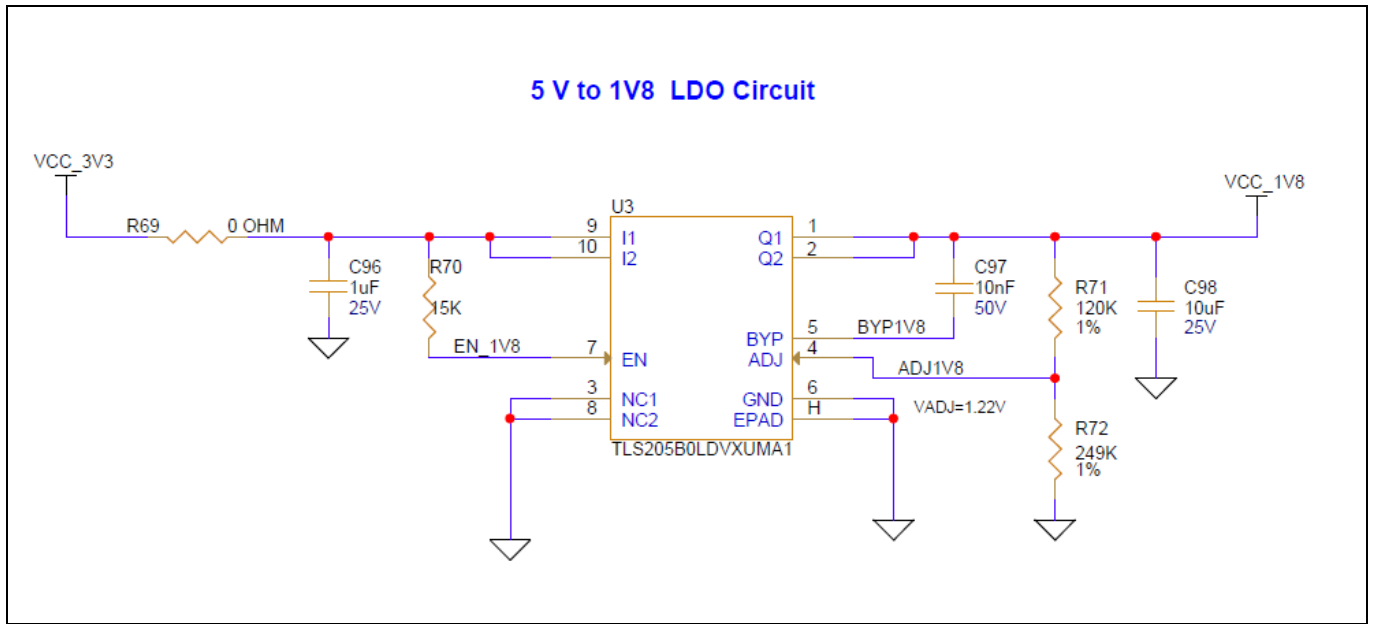

Figure 18 1V8 regulator circuit

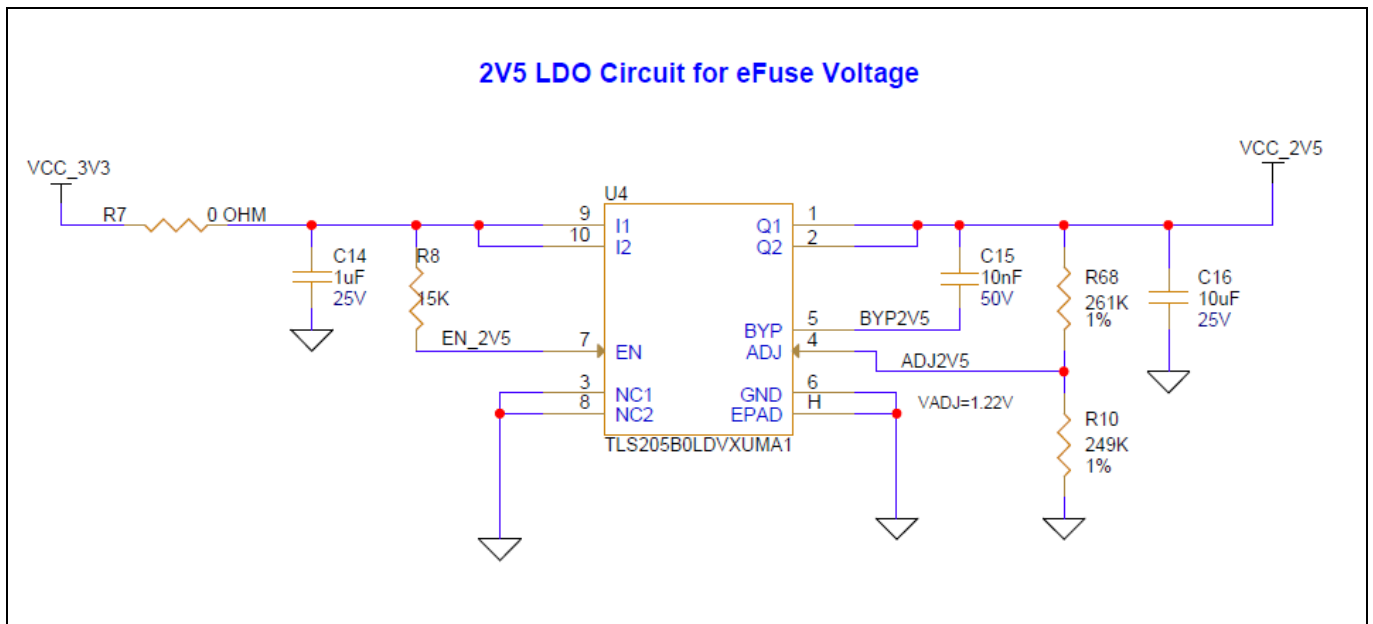

Figure 19 2V5 regulator circuit

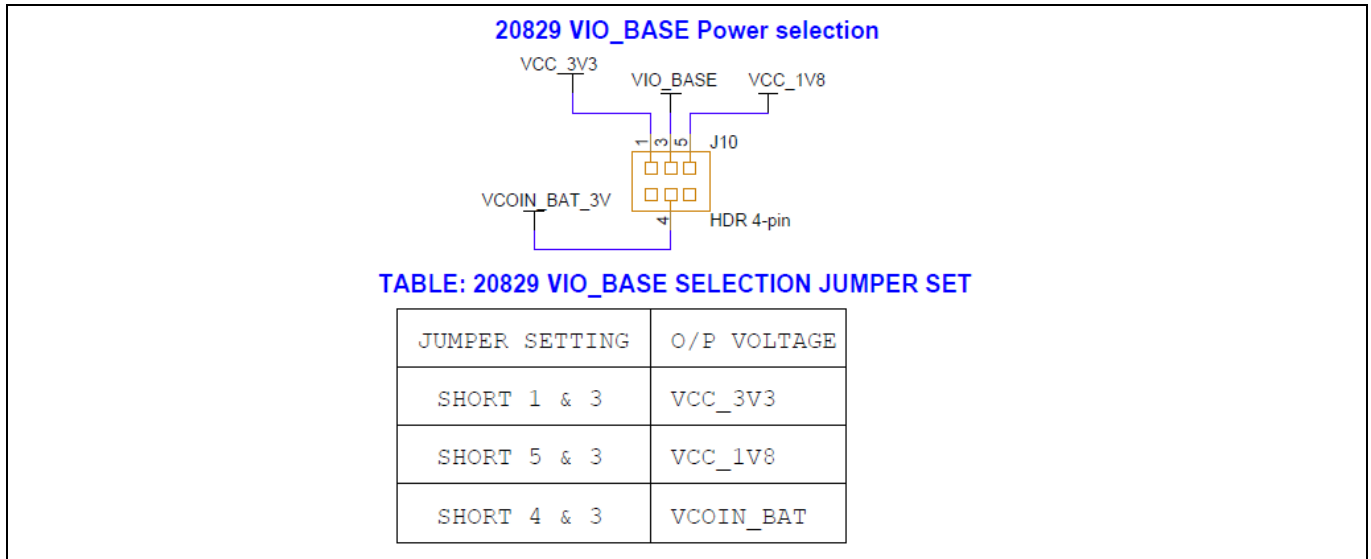

Figure 20 Jumper J10 for VDDIO selection

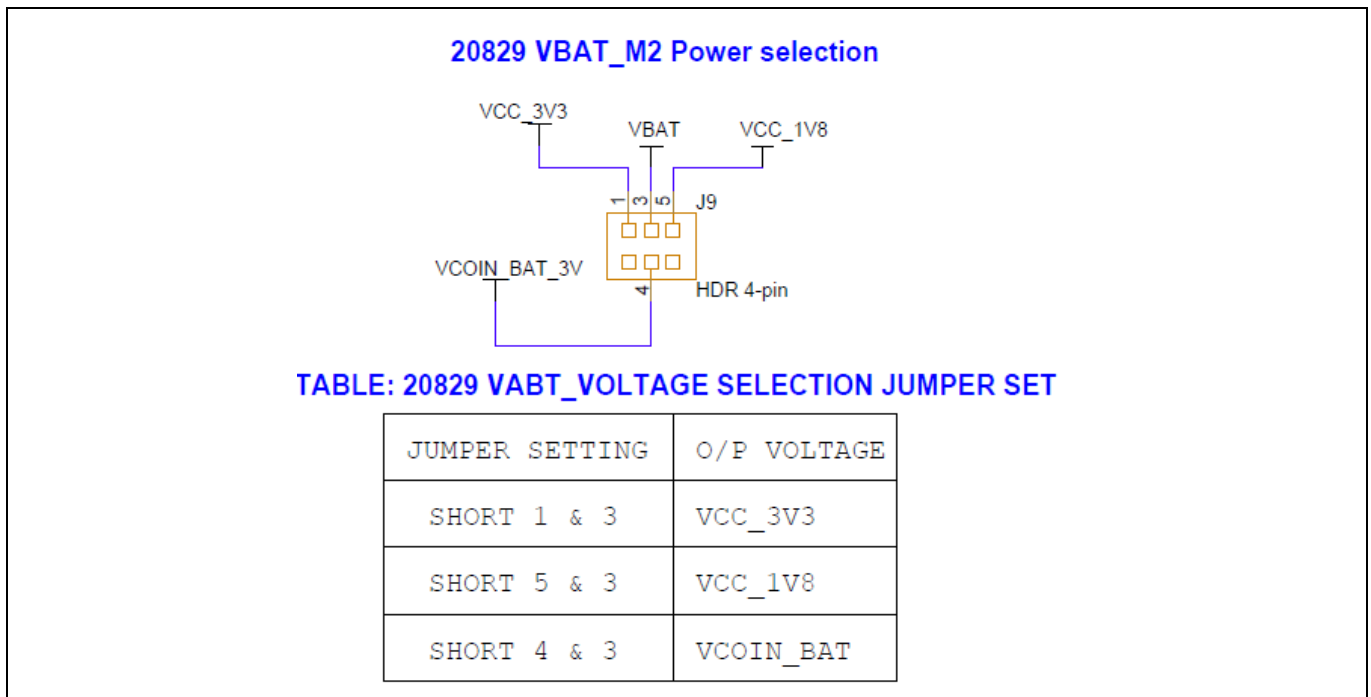

Figure 21 Jumper J9 for VBAT selection

Hardware

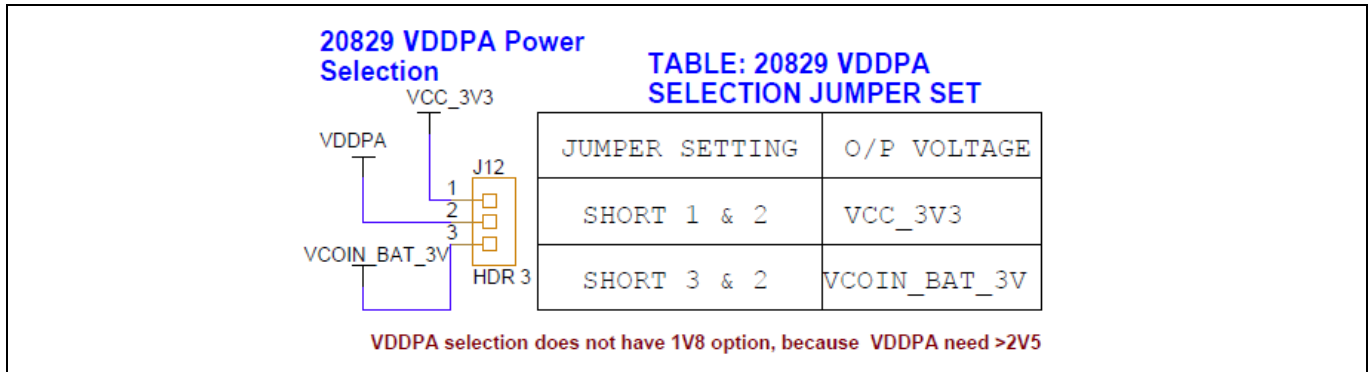

Figure 22 Jumper J12 for VDDPA selection

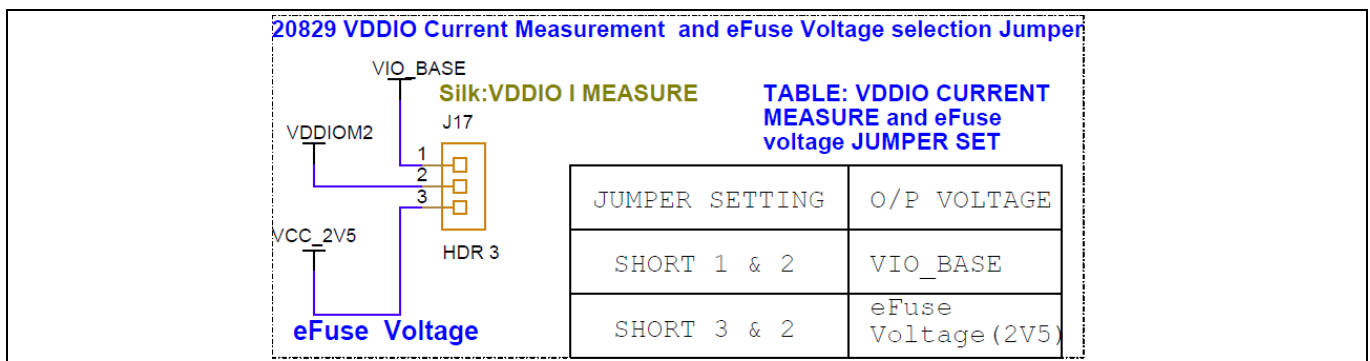

Figure 23 Jumper J17 for VDDPA selection

3.2.3 Device reset

The reset circuit on the board consists of a reset button (SW1) connected to the ground with an optional pull-up resistor and decoupling capacitor. Release the BT_RST_N on CYW20829 with the delay of 50 ms or more after the VDDIO supply voltage is stabilized. The voltage-detector IC is used to provide this delay.

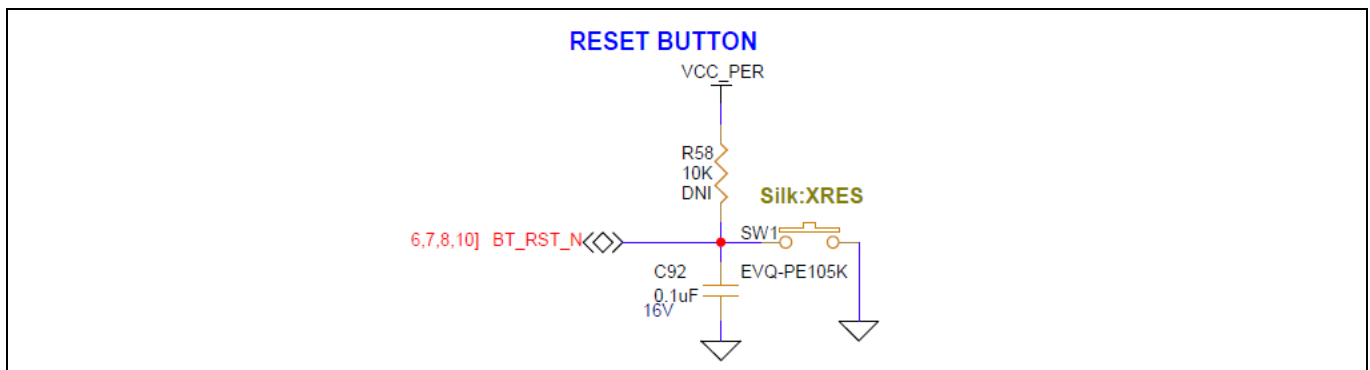

Figure 24 Reset button circuit in baseboard

Hardware

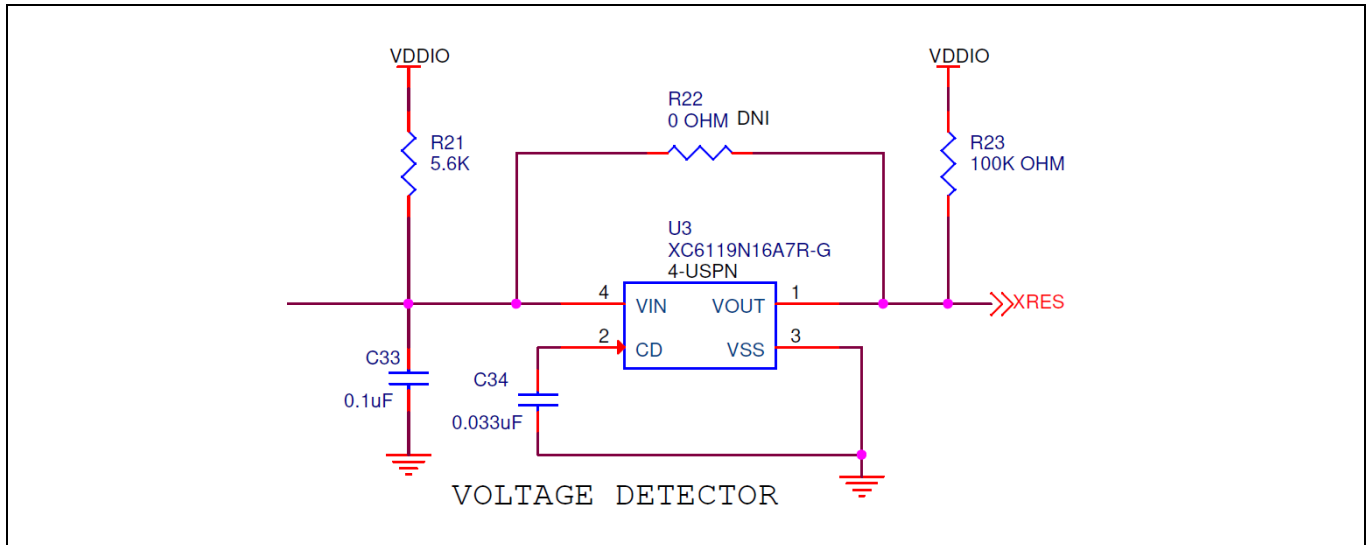

Figure 25 Voltage detector circuit in the carrier module

3.2.4 Thermistor

The thermistor circuit is a simple voltage divider circuit consisting of an NTC thermistor that is 10 kΩ at 25°C and a fixed 10 kΩ resistor. The divided voltage is fed into A0, and the voltage level determines the ambient temperature. The part number of the thermistor used on this kit is NCP18XH103F03RB.

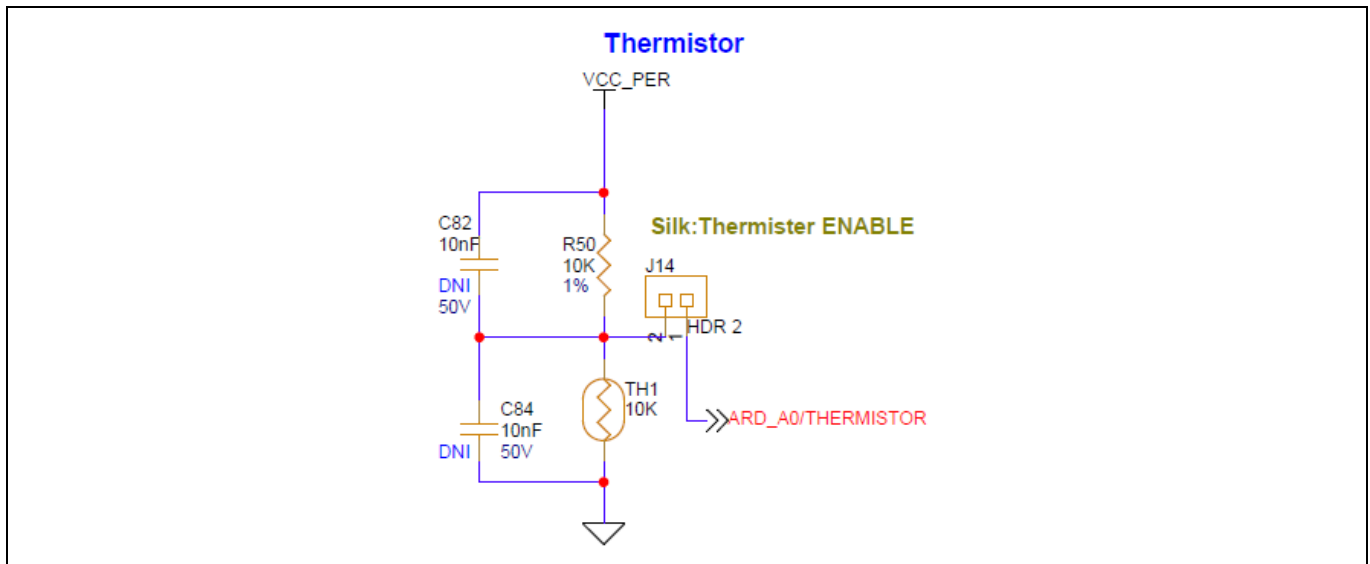

Figure 26 Thermistor circuit

3.2.5 External serial flash

CYW920829B0M2P4XXI100-EVK has a Giga device 8 Mb serial flash (GD25WQ80ETFG) on the baseboard, which can be useful when the user application requires more memory. The Bluetooth® SDK is compatible with most JEDEC CFI-compliant SPI flash ICs. The SPI driver should configure the respective pins in the user application to use the onboard serial flash (no load by default).

Hardware

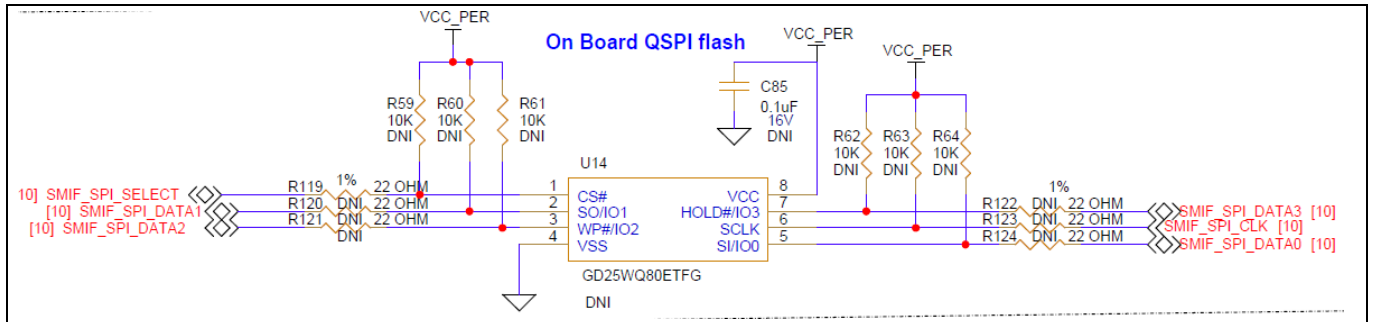

Figure 27 External serial flash

3.2.6 Inertial measurement unit (IMU)

An onboard IMU sensor will be available to sense the position of the kit, used to measure the acceleration and angular velocity, when combined with sensor fusion software. This can be used to determine the motion, orientation, and heading of the kit. The CYW20829 device communicates with this sensor over I²C. By default, the I²C address is '0x68', and can be changed using the resistor options (R127 and R128). See the BMI323 datasheet for more details.

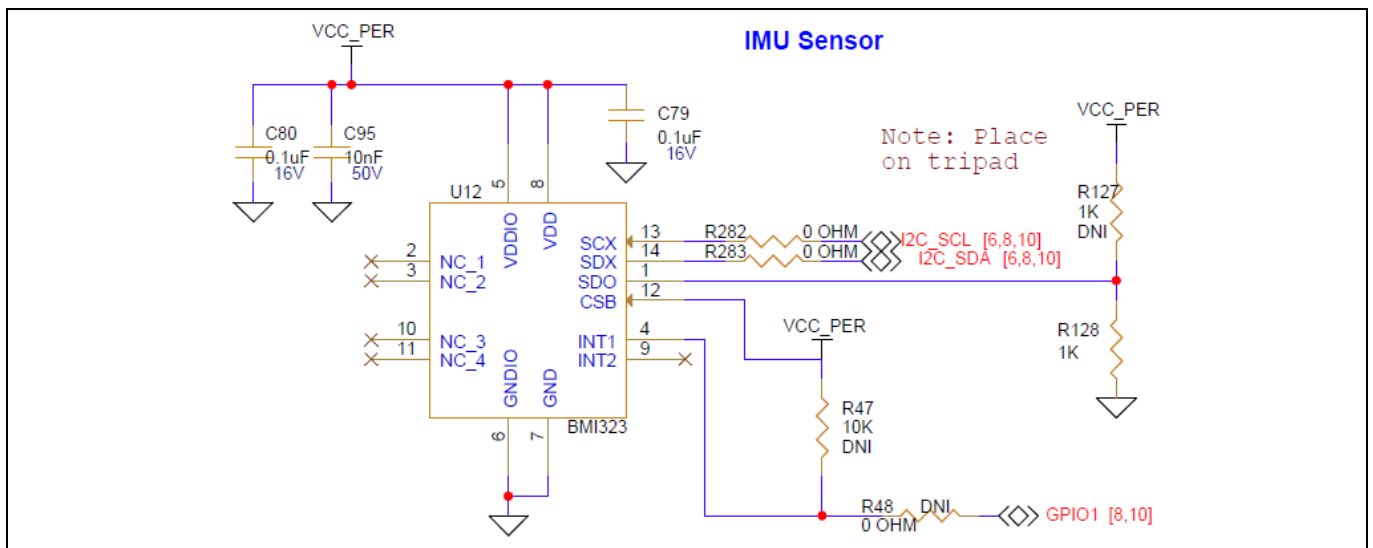

Figure 28 IMU sensor circuit

3.2.7 LEDs

There are two onboard user LEDs on the kit. P1.1 and P5.2 to control the LED3 and LED4, respectively. The LEDs can be enabled or disabled using the resistors R41 and R42.

Hardware

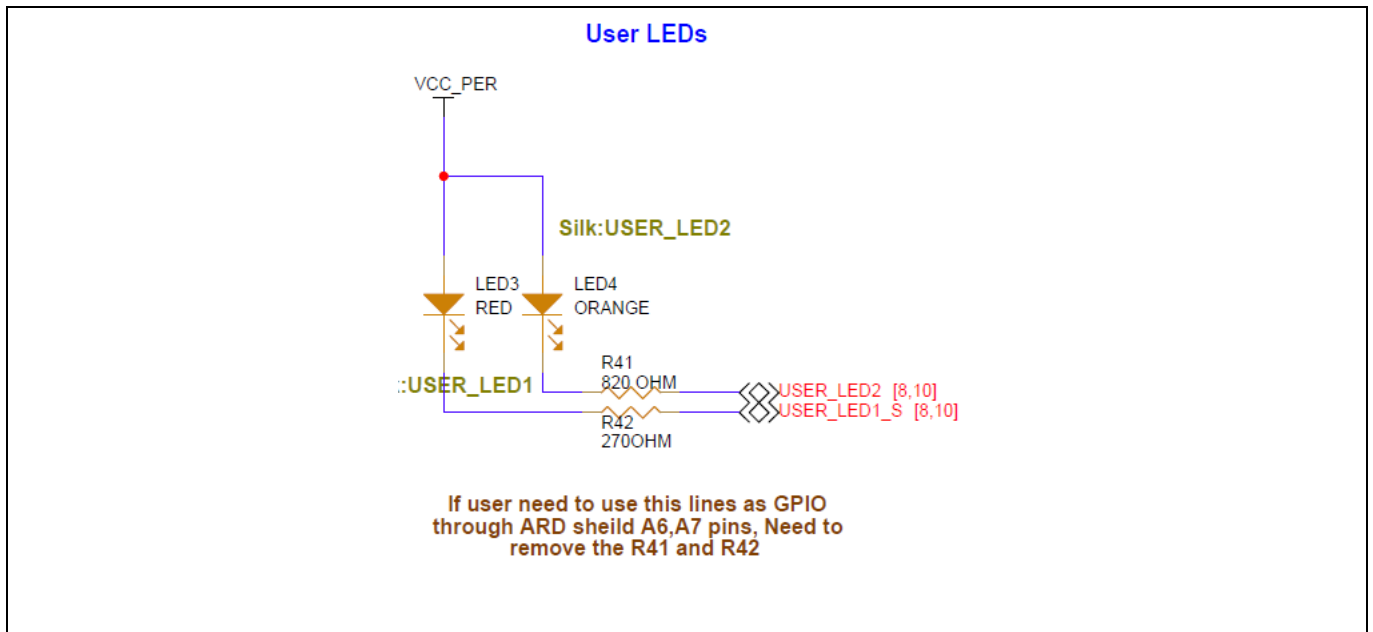

Figure 29 LED circuit

3.2.8 Push buttons

CYW920829M2EVK-02 has one reset and two user buttons. See the [Device reset](#) section for details on the reset button. The user button1 (SW2) is connected to pin P0.5 of the CYW20829 device, which can work in Deep Sleep mode and the user button2(SW4) is connected to pin P1.0 of the CYW20829 device.

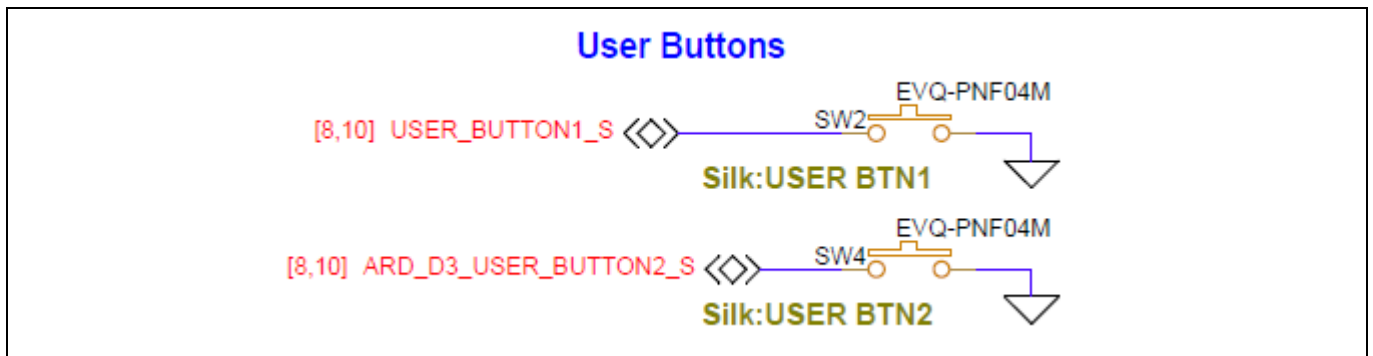

Figure 30 Push buttons

3.2.9 Digital microphone (DMIC)

A DMIC is provided on the baseboard, is interfaced with the CYW20829 device through the dedicated PDM interface and powered from the VCC_PER rail. The SELECT pin on each microphone is biased such that data gives either a HIGH or LOW of the clock signal. The DMIC is used to execute the voice remote code example in the kit.

Hardware

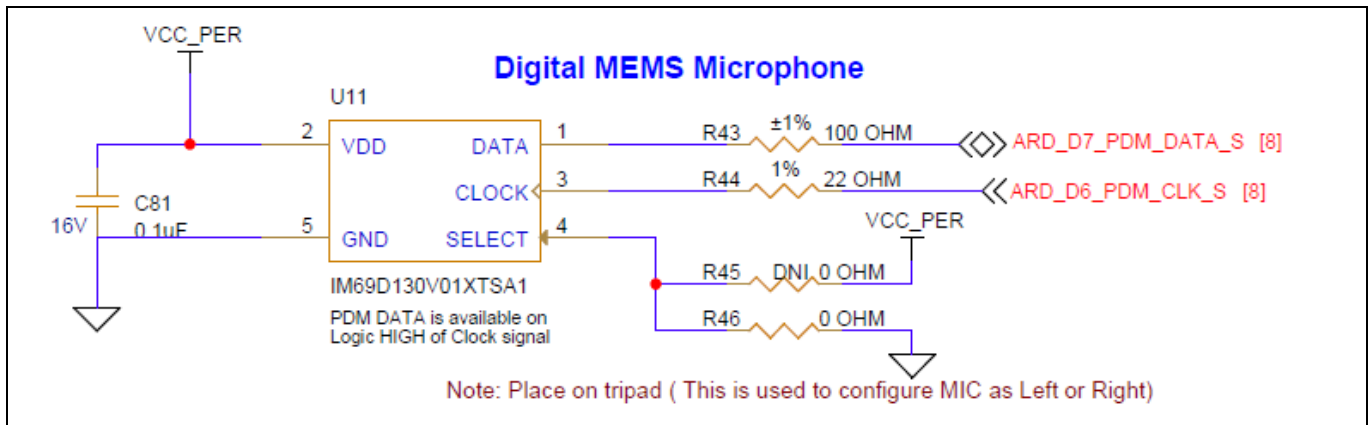

Figure 31 DMIC circuit

3.2.10 Analog microphone (AMIC)

An analog MEMS microphone is provided on the baseboard for analog audio application. The differential output AMIC is interfaced with CYW20829 device through the dedicated analog microphone input pin and AGND pin. This AMIC is powered by the MIC_BIAS rail from CYW20829 device. The AMIC is used to execute the voice remote code example in the kit.

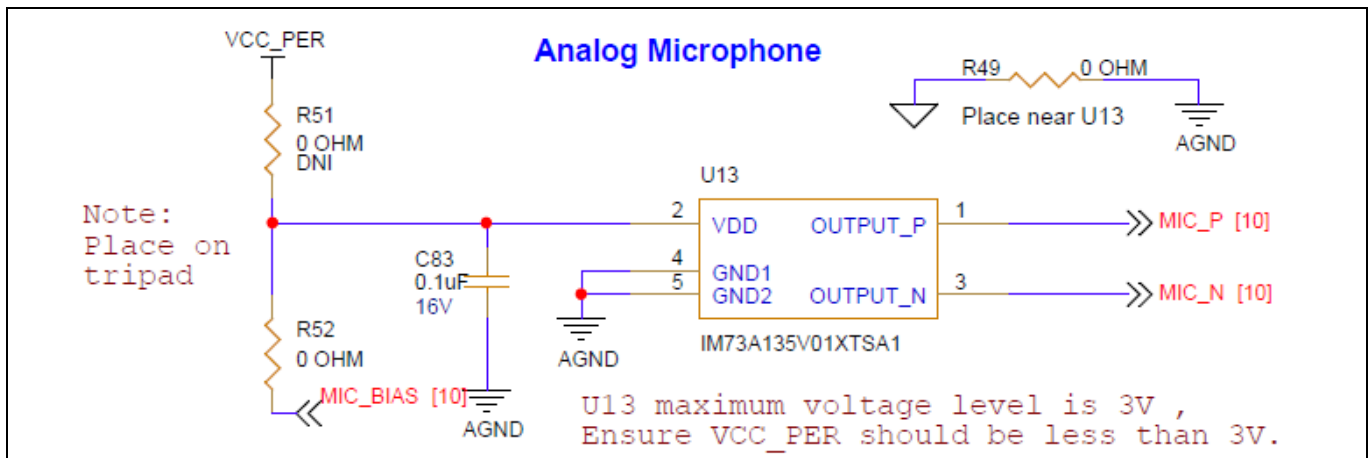

Figure 32 AMIC circuit

3.2.11 RGB LED

An RGB LED is available in the baseboard which is controlled through dedicated three digital GPIOs. The three GPIOs are driven from CYW20829 silicon to drive the RGB LED. Port 0.2, Port 0.3, and Port 0.4 are used for red, green, and blue LEDs. Power supply is provided from VCC_PER rail and series current limiting resistor is given according to the bias current of 5 mA.

Hardware

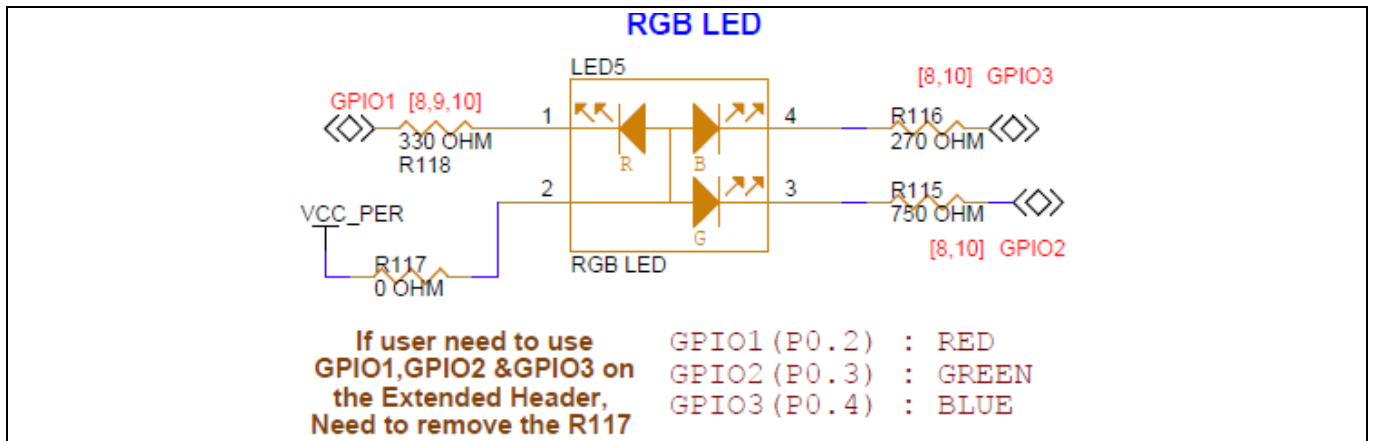

Figure 33 RGB LED circuit

3.2.12 10-pin SWD header

A 10-pin (50 mil pitch) SWD header is provided for the programming and debugging of the target CYW20829 device using an external programmer such as MiniProg4.

VDDIO (3V3/3V/1V8) will be supplied from the onboard LDO via reverse protection circuit to restrict Kit operation by the programmer power.

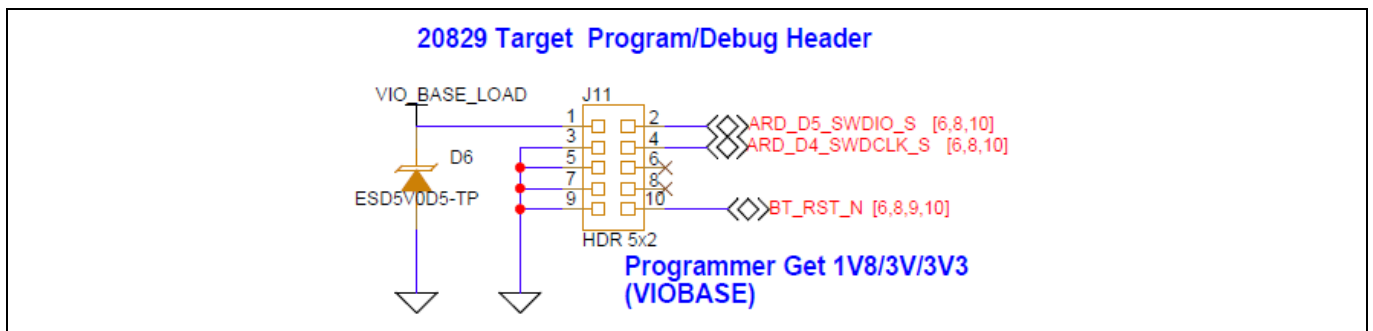

Figure 34 10-pin SWD programming/debug header

3.2.13 Arduino-compatible and extended headers

The baseboard supports the generic Arduino-compatible Uno shields and selected Infineon custom defines Arduino-compatible shields. All the CYW20829 GPIO pins are brought out to Arduino-compatible headers. Some pins with fixed functions are also multiplexed through 0 Ω or jumper and connected to the headers.

The I/O headers J1-J4, whose position and pin map comply with the Arduino-compatible UNO R3 kit to support Arduino-compatible shields. The system power signals are brought to the pins of J1.

The power supply pins for Arduino-compatible VCC_ARD_3V3 and VCC_ARD_5V0 connect to VCC_3V3 and KP_VBUS through reverse voltage protection circuits.

All GPIOs of the CYW20829 device are at 3V3/3 V/1V8 level-based on the selected jumper position in VDDIO power selection. To establish compatibility with the existing Arduino shields, all GPIOs are level mapped with the same VDDIO in the baseboard.

Hardware

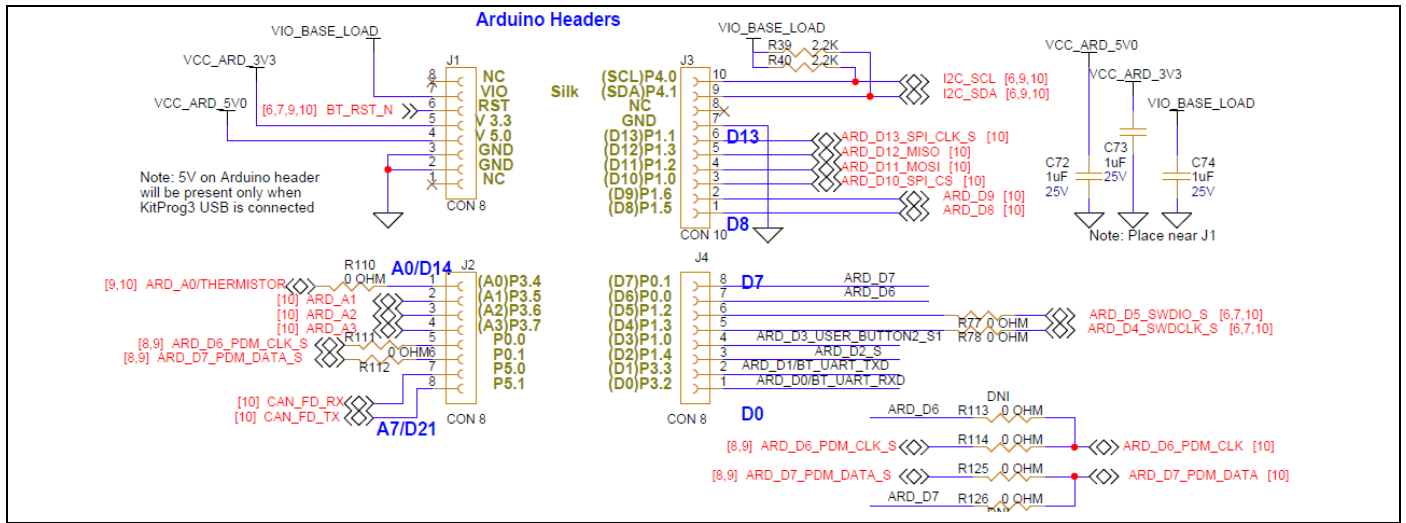

Figure 35 Arduino-compatible and extended headers

Evaluation Kit user guide

CYW20829 device I/O mapping

4 CYW20829 device I/O mapping

Table 17 maps the CYW20829 device I/Os to headers and sensors on the baseboard. It also lists the carrier module interface definition.

Table 17 Carrier module interface and pin connections

Carrier module pin	Carrier module pin name	CYW20829 pin	Baseboard connection 1	Baseboard connection 2	Baseboard connection 3
1	GND	GND	GND	-	-
2	VPA_BASE	VDDD	VDDPA	J12.2	-
3	NC	NC	NC	-	-
4	VPA_BASE	VDDD	VDDPA	J12.2	-
5	NC	NC	NC	-	-
6	USER_LED1	P1.1	USER_LED1	LED3	J18.1
7	GND	GND	GND	-	-
8	ARD_D18	P0.2	GPIO1	LED5.1	J18.4
9	ARD_D13_SPI_CLK	P0.4	ARD_D13	LED5.4	J18.6
10	ARD_D19	P0.3	GPIO2	LED5.3	J18.5
11	ARD_D8	P1.5	ARD_D8	J3.1	-
12	ARD_D6_PDM_CLK	P0.0	ARD_D6_PDM_CLK	U11.3	J2.5
13	NC	NC	NC	-	-
14	ARD_D7_PDM_DATA	P0.1	ARD_D7_PDM_DATA	U11.1	J2.6
15	NC	NC	NC	-	-
16	USER_LED2	P5.2	USER_LED2	LED4	J18.2
17	ARD_A0/Thermistor	P3.4	ARD_A0/Thermistor	J14.1	J2.1
18	GND	GND	GND	-	-
19	ARD_A1	P3.5	ARD_A1	J2.1	-
20	NC	NC	NC	-	-
21	ARD_D10_SPI_CS	P5.1	CAN_FD_TX	J2.8	-
22	BT_UART_TXD	P3.3	BT_UART_TXD	U5_P12.7	-
23	ARD_D2	P1.4	ARD_D2	J4.3	-
32	BT_UART_RXD	P3.2	BT_UART_RXD	U5_P12.6	-
33	RSVD_10	P2.5	SMIF_SPI_CLK	U14.6	-
34	BT_UART_RTS	P3.1	BT_UART_RTS	U5_P15.5	-
35	ARD_D4_SWDC LK	P1.3	ARD_D4_SWDC LK	U5_P12.3	J4.5
36	BT_UART_CTS	P3.0	BT_UART_CTS	U5_P1.6	-
37	ARD_D5_SWDI O	P1.2	ARD_D5_SWDI O	U5_P12.2	J4.6

Evaluation Kit user guide
CYW20829 device I/O mapping

Carrier module pin	Carrier module pin name	CYW20829 pin	Baseboard connection 1	Baseboard connection 2	Baseboard connection 3
38	ARD_D3_USER_BUTTON2	P1.0	ARD_D3_USER_BUTTON2	SW4	J4.4
39	GND	GND	GND	-	-
40	ARD_D9	P1.6	ARD_D9	J3.2	-
41	NC	NC	NC	-	-
42	VCC_2V5	VDD2P5	VCC_2V5	U4.1	J17.3
43	NC	NC	NC	-	-
44	NC	NC	NC	-	-
45	GND	GND	GND	-	-
46	NC	NC	NC	-	-
47	MIC_P	MIC_P	MIC_P	U13.1	-
48	NC	NC	NC	-	-
49	MIC_N	MIC_N	MIC_N	U13.3	-
50	EXT_LPO	P5.0	LPO_OUT	J2.7	-
51	GND	GND	GND	-	-
52	NC	NC	NC	-	-
53	MIC_BIAS	MIC_BIAS	MIC_BIAS	U13.2	-
54	RST_N	XRES	BT_RST_N	SW1	U5_P12.4
55	NC	NC	NC	-	-
56	RSVD_9	P2.0	SMIF_SPI_SELECT	U14.1	-
57	GND	GND	GND	-	-
58	I2C_SDA/SPI_MISO	P4.1	I2C_SDA_S	U5_15.2	J3.9
59	RSVD_2	P2.2	SMIF_SPI_DATA2	J12.2	-
60	I2C_SCL/SPI_MOSI	P4.0	I2C_SCL_S	U5_15.1	J3.10
61	USER_BUTTON1	P0.5	USER_BUTTON1	SW2	J18.3
62	NC	NC	NC	-	-
63	NC	NC	NC	-	-
64	VIO_BASE	VDDIO	VDDIOM2	J17.2	-
65	ARD_A3	P3.7	ARD_A3	J2.4	-
66	RSVD_7	P2.3	SMIF_SPI_DATA1	U14.2	-
67	ARD_A2	P3.6	ARD_A2	J2.3	-
68	RSVD_6	P2.4	SMIF_SPI_DATA0	U14.5	-
69	GND	GND	GND	-	-

Evaluation Kit user guide**CYW20829 device I/O mapping**

Carrier module pin	Carrier module pin name	CYW20829 pin	Baseboard connection 1	Baseboard connection 2	Baseboard connection 3
70	RSVD_5	P2.1	SMIF_SPI_DATA 3	U14.7	–
71	NC	NC	NC	–	–
72	VBAT	VBAT	VBAT	J9.3	–
73	NC	NC	NC	–	–
74	VBAT	VBAT	VBAT	J9.3	–
75	GND	GND	GND	–	–

Kit rework

5 Kit rework

5.1 SMIF interface for baseboard flash

The kit is provisioned with an optional QSPI SMIF-based flash in the baseboard. To isolate the default flash available in the M.2 board and use the optional baseboard flash, a rework is needed in the kit. The SMIF memory interface I/Os are shared between the SMIF QSPI flash of the baseboard and the M.2 board flash.

To perform the necessary rework on the board by removing or adding the corresponding 0 Ω resistors to work with baseboard SMIF memory modules. See [Table 18](#) for resistor rework details for SMIF.

Table 18 Base board flash and M.2 connector interface multiplexing

CYW920829M2IPA2 M.2 board function		Baseboard	CYW20829 pin
SMIF interface to QSPI flash in baseboard	SMIF interface to QSPI flash in M.2 board	SMIF interface to QSPI flash in baseboard	-
R14 position B*	R14 position A	Mount (U14, R119, R120, R121, R122, R123, R124, R59, R60, R61, R62, R63, R64, C85) *	P2.3
R15 position B*	R15 position A		P2.4
R16 position B*	R16 position A		P2.5
R17 position B*	R17 position A		P2.0
R18 position B*	R18 position A		P2.2
R19 position B*	R19 position A		P2.1

*: By default, not connected.

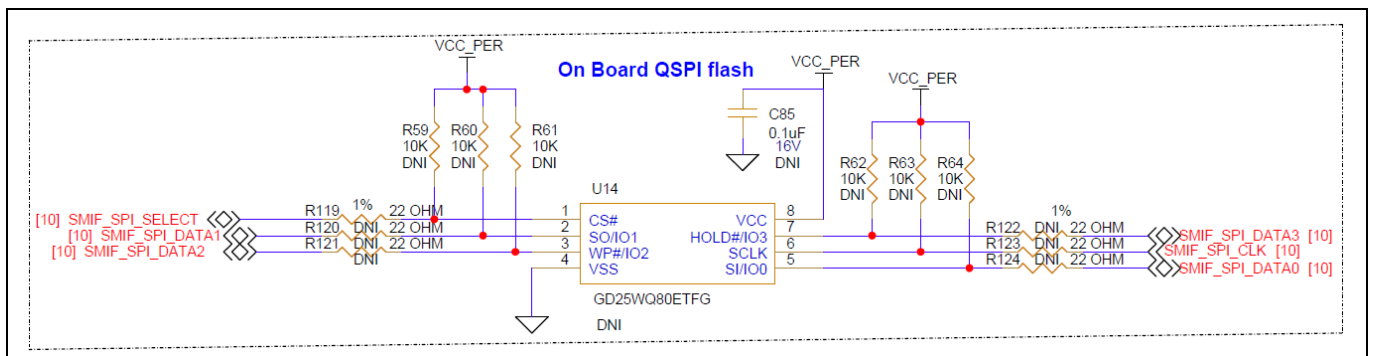

Figure 36 SMIF memory interface in baseboard

Kit rework

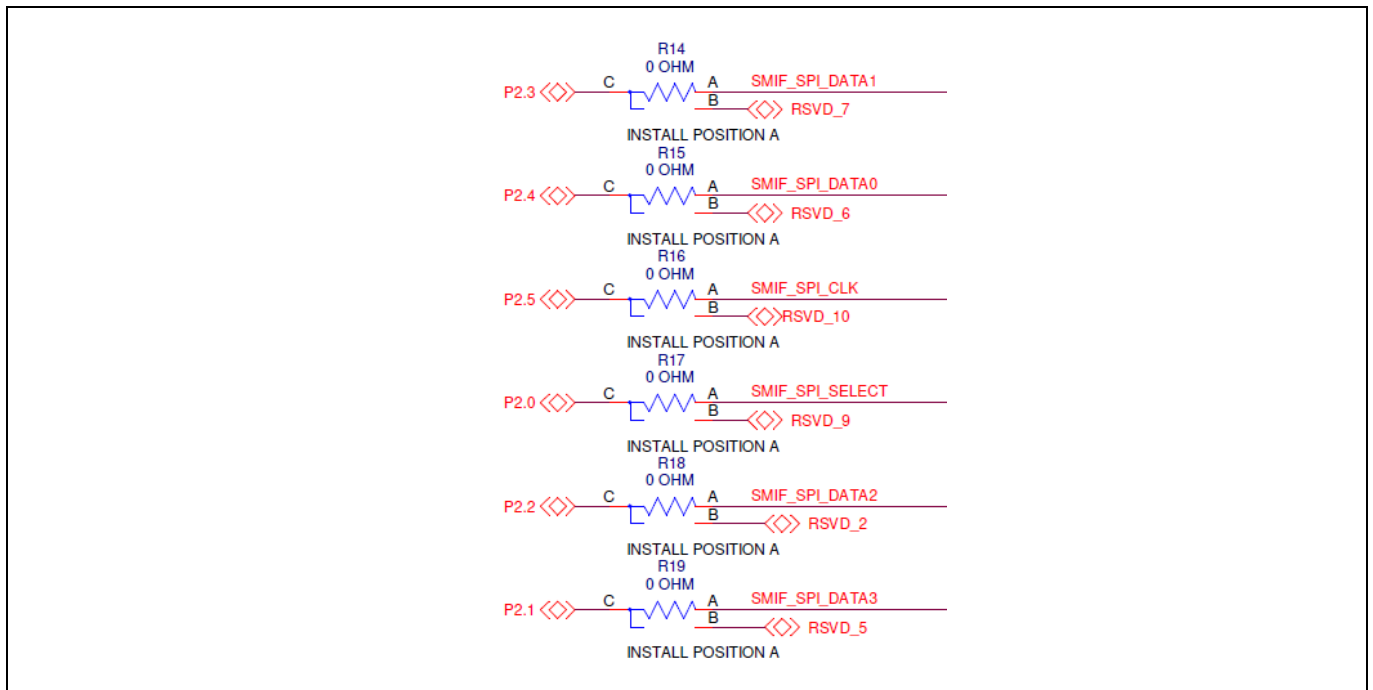

Figure 37 Mounting option to select SMIF memory and M.2 board flash (available in M.2 board)

Kit rework

5.2 UART interface on headers compatible with Arduino-standard

The UART interface signals are connected between the PSoC™ 5LP device and CYW20829. The same signals have been shared across digital interface connectors compatible with Arduino J4.1–J4.2. For using UART lines on a connector compatible with Arduino, perform the board rework with the specific resistor assembly.

Baseboard		CYW20829 pin
UART interface to Kitprog3	UART interface to Arduino shield/extended header	---
R34	R33*	BT_UART_RXD
R36	R38*	BT_UART_TXD
R107	R106*	BT_UART_CTS
R108	R109*	BT_UART_RTS

*: Not connected by default.

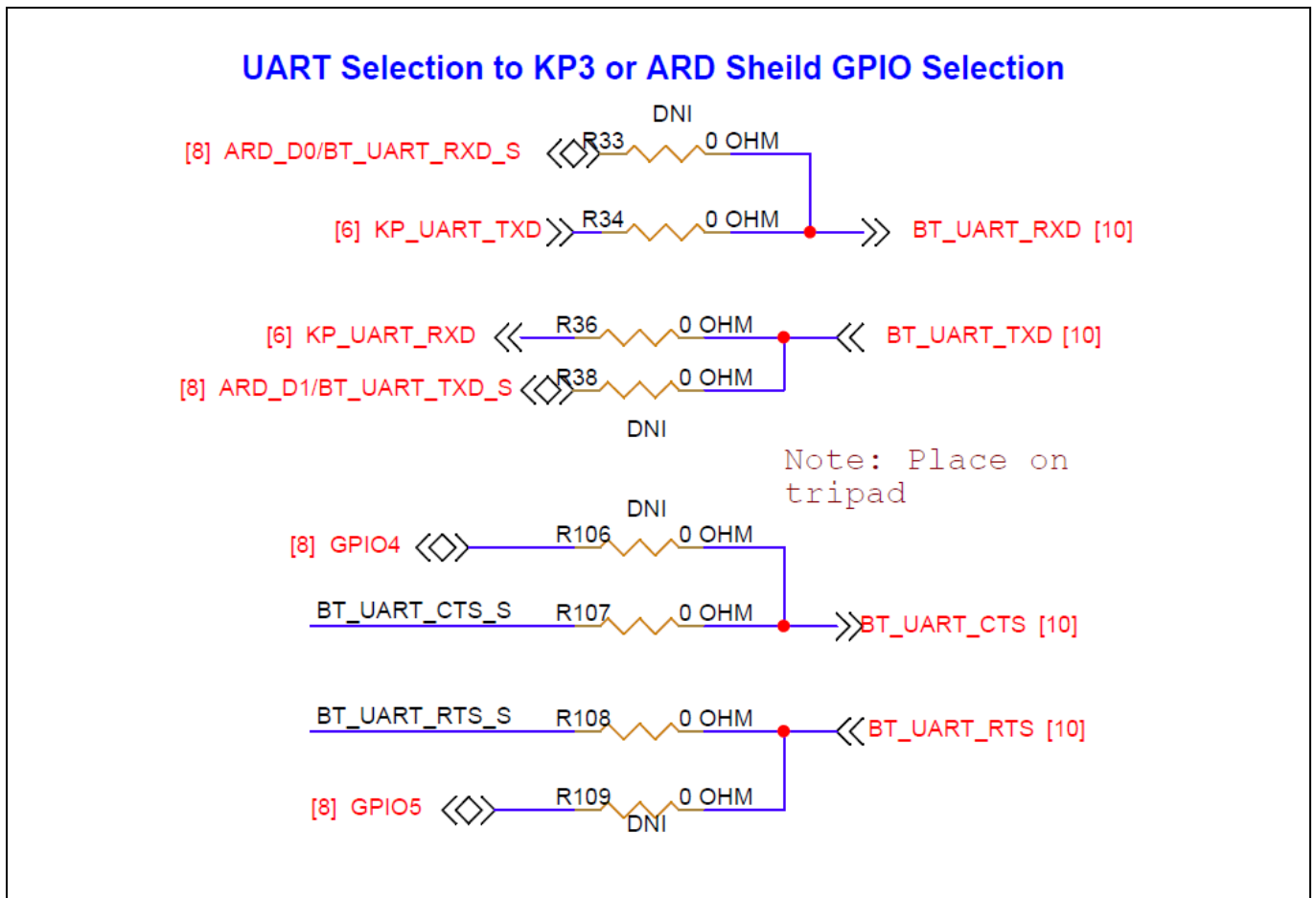

Figure 38 UART signals mounting option

Kit rework

5.3 SPI interface selection

The default SPI lines are not configured in the kit. To enable the SPI option and route to the Arduino shield by following the rework.

- Default P1.0 is connected to USER_BTN2 via R87, remove it and install R104 to use SPI_CS
- Default P1.1 is connected to USER_LED1 via R90, remove it and install R105 to use SPI_CLK
- Default P1.3 is connected to SWDCLK via SW6 POS1, change it to POS2 to use SPI_MISO
- Default P1.2 is connected to SWDIO via SW6 POS1, change it to POS2 to use SPI_MOSI

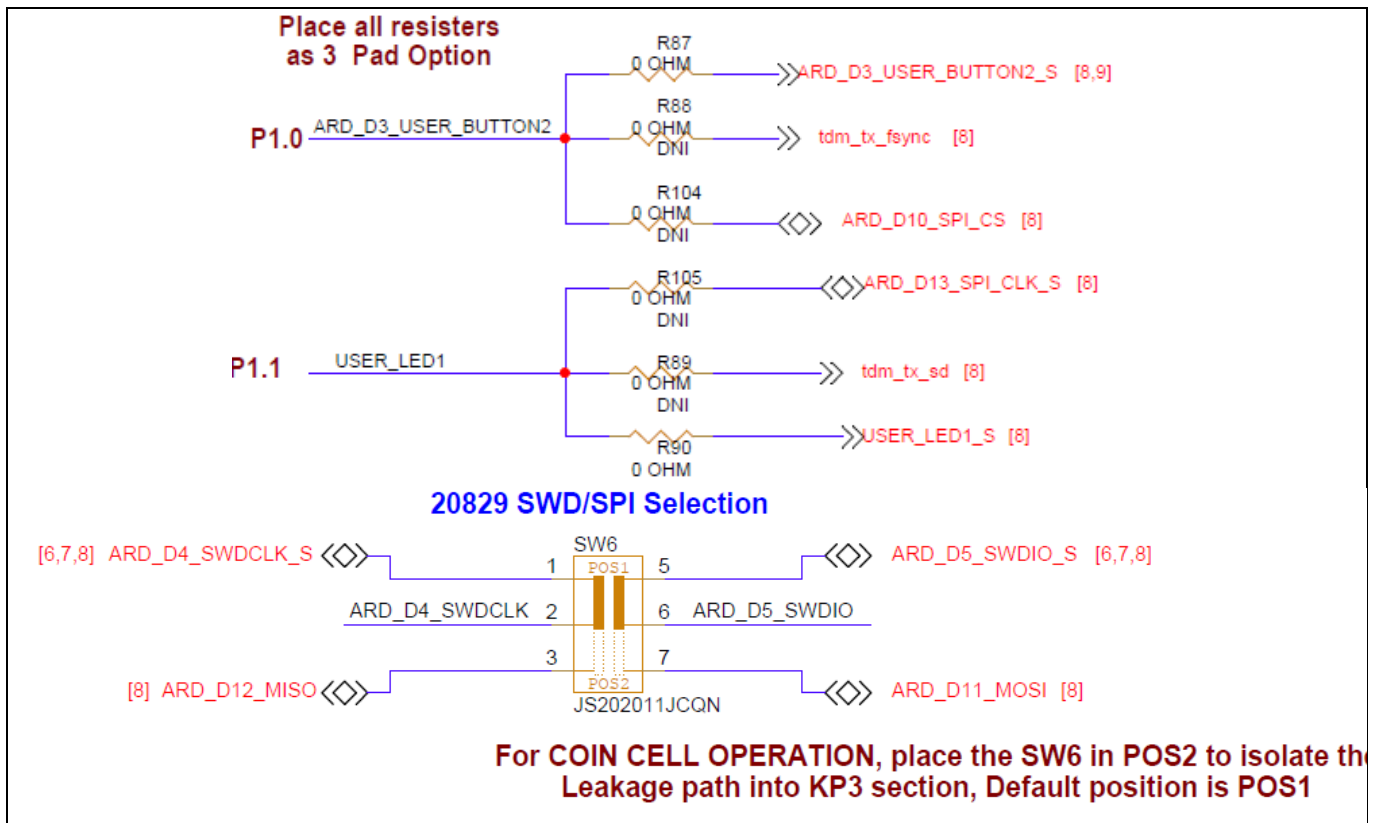

Figure 39 SPI interface selection

Kit rework

5.4 I2S interface selection

The default I2S lines are not configured in the kit. To enable the I2S interface and route to the Arduino shield by following the rework.

- Default P0.4, P3.2 is connected to RGB LED, UART_RX via R83, R95 remove these and install R84, R96 to use I2S_MCLK
- Default P0.5, P3.3 is connected to USER_BTN1, UART_TX via R86, R98 remove these and install R85, R97 to use I2S_TX_SCK
- Default P1.0, P1.4 is connected to USER_BTN2, D2 via R87, R91 remove it and install R88, R92 to use I2S_TX_WS
- Default P1.1, P1.4 is connected to USER_LED1, USER_BTN2 via R90, R94 remove these and install R89, R93 to use I2S_TX_DATA

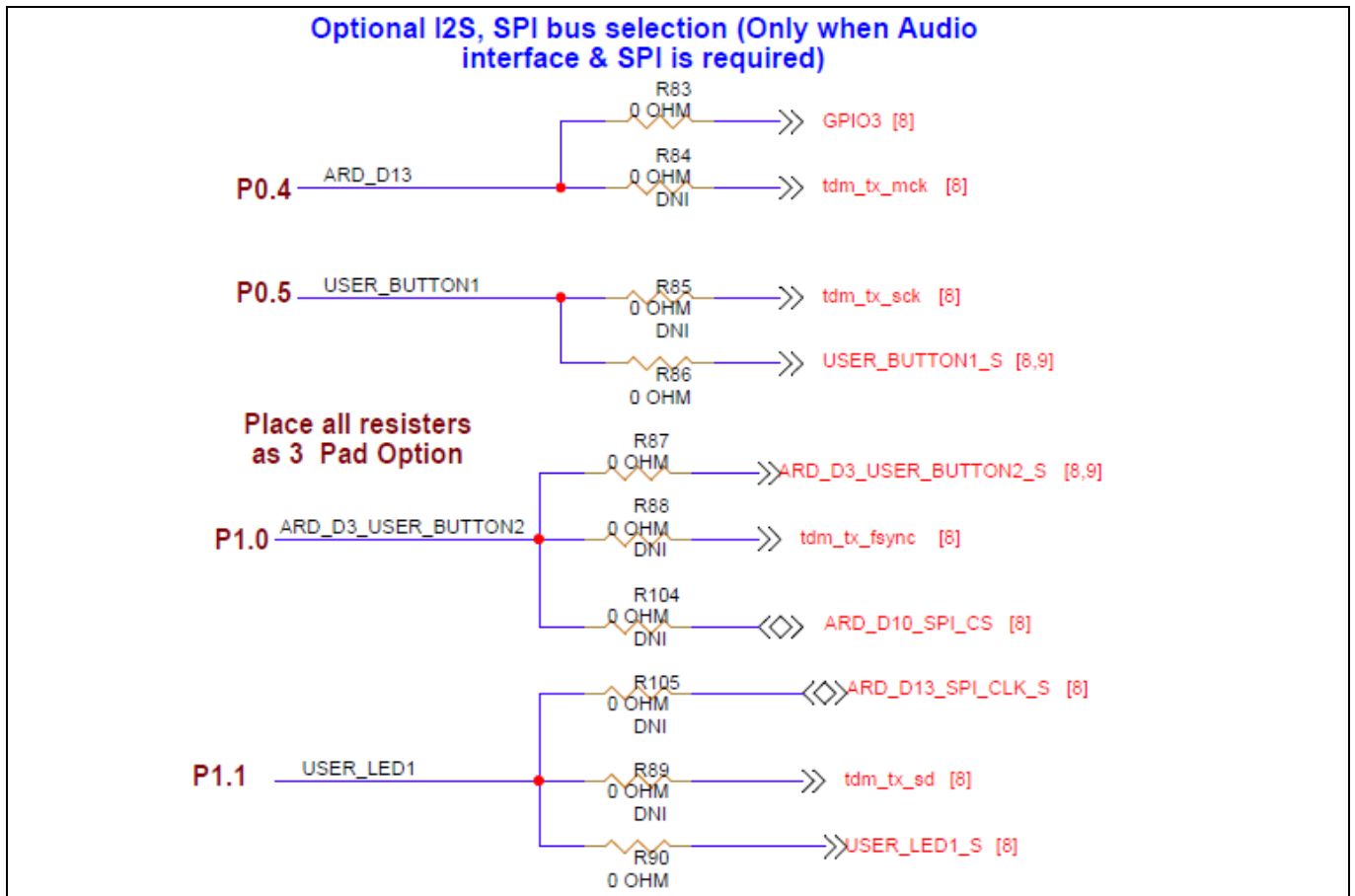

Kit rework

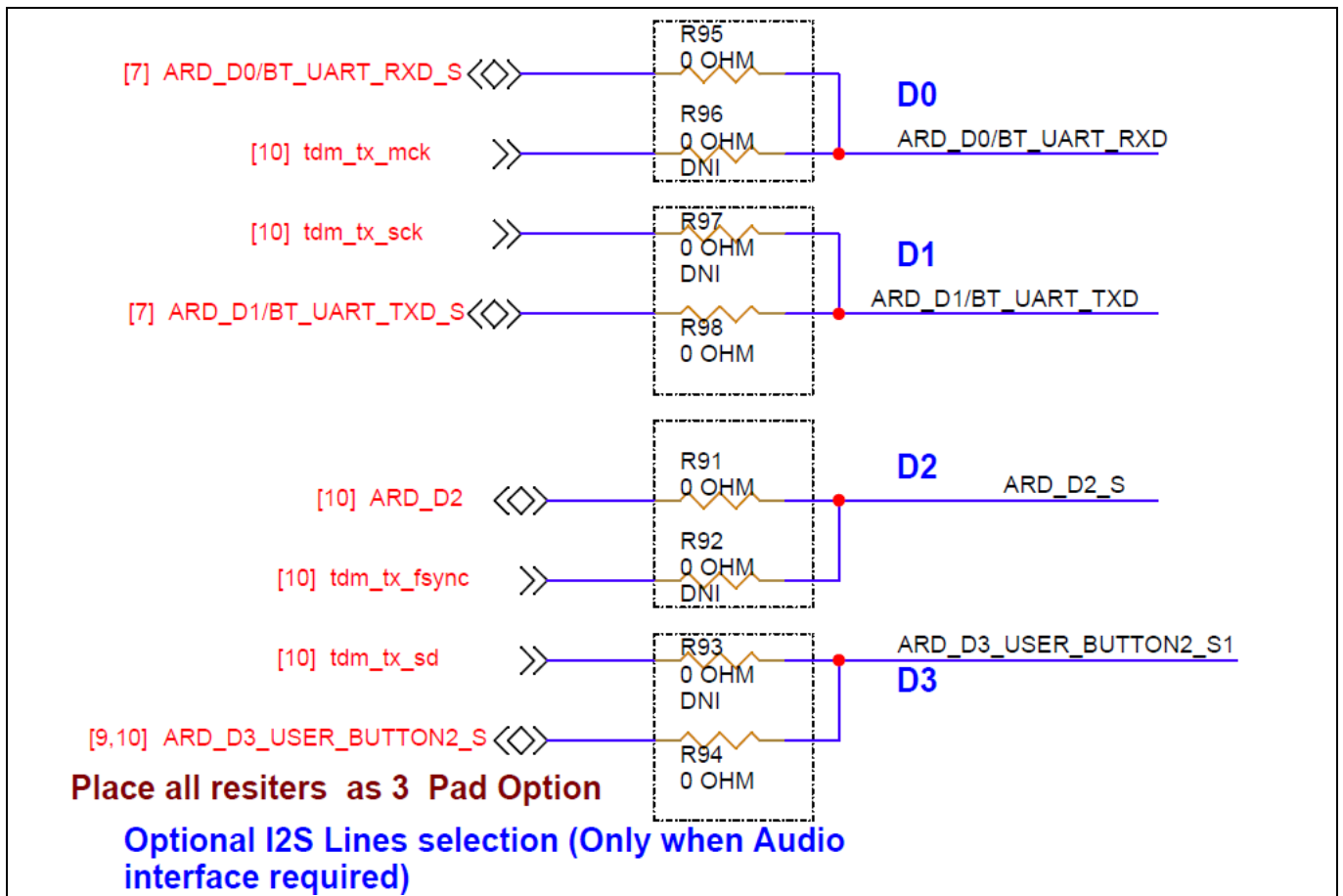

Figure 40 I2S interface selection

5.5 IMU interrupt signal selection

On the kit, the default connection is made for the RGB LED interface. To use the IMU INT1 signal, remove R117 and install R48 to use the CS and INT1 pin of the IMU.

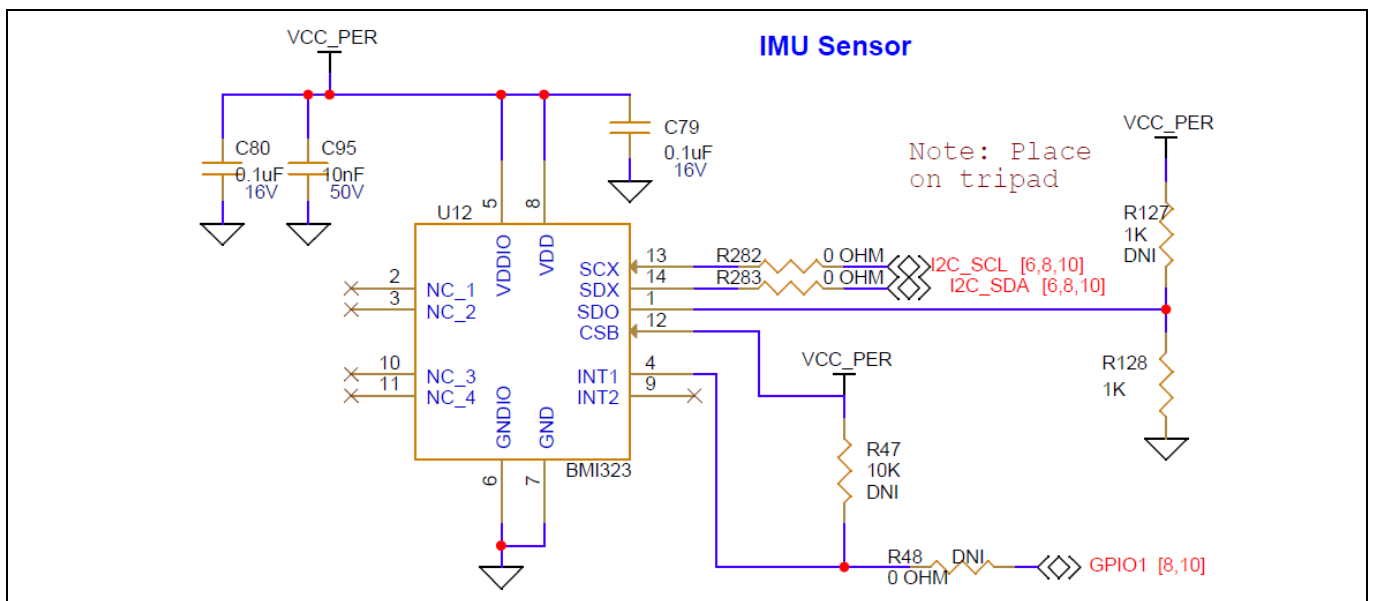

Figure 41 IMU INT1 interface selection

6 Frequently asked questions

1. How can I access the SPI (MOSI, MISO) signals that are shared with SWDCLK and SWDIO GPIOs?

- P1.2 is used for ARD_D5_SWDIO and ARD_D11_MOSI in the kit
- P1.3 is used for ARD_D5_SWDCLK and ARD_D12_MISO in the kit

By default, P1.2 and P1.3 are connected via SW6 POS1 to use as SWD ports in the kit. Therefore, Change it to POS2 in SW6 to enable P1.2 and P1.3 as SPI lines: ARD_D11_MISO and ARD_D11_MOSI.

2. How can I access the SPI (CS, CLK) signals that are shared with User Button2 and USER LED1?

- P1.0 is used for ARD_D3_USER_BUTTON2_S and ARD_D10_SPI_CS in the kit
- P1.1 is used for ARD_D13_SPI_CLK_S and USER_LED1_S in the kit

By default, P1.0 is connected to USER_BTN2 via R87; remove it and install R104 to use SPI_CS. Similarly, P1.1 is connected to USER_LED1 via R90; remove it and install R105 to use SPI_CLK.

3. A secondary UART using SCB1 is not connected via KitProg3. How can I access this UART?

P1.2 and P1.3 ports operate as a secondary UART; the TX and RX lines of this UART are available in J4.5 and J4.6. To use SCB1 UART, connect the UART lines from Arduino-compatible shield pins D4 and D5 to MiniProg4 or through FTDI.

4. SCB2 I2C (P5.0, P5.1) pins are not working as I2C master?

- Resistor pull-ups are not given. By default, the same pins are used for CANFD
- Follow any one of the methods to make SCB2 work as a master
 - Use the SCB0 I2C pins (P4.0, P4.1) as master and loop back the SCB2 I2C pins (P5.0, P5.1)
 - Hardware Abstraction Layer (HAL): Connect the external pull-up resistors
 - Peripheral Driver Library (PDL): Enables the SCB from the device configurator and change the pin drive mode from “open drain, drives low, input buffer on” to “resistive pull-up, input buffer on”

5. Why can't we use P1_0, P1_1, P1_2, and P1_3 during DS RAM mode of operation?

When the device is in DS-RAM mode, the following pins are used for SWD operation:

- P1_0_CPUSS_SWJ_SWO_TDO
- P1_1_CPUSS_SWJ_SWDOE_TDI
- P1_2_CPUSS_SWJ_SWDIO_TMS
- P1_3_CPUSS_CLK_SWJ_SWCLK_TCLK

To utilize these pins, disable the Debug mode before the device enters DS-RAM mode by using `Cy_Syslib_SetWarmBootEntryPoint()` API. To disable the Debug mode in DS-RAM, the second parameter in the API is set to 'False'. If the Debug mode is disabled, the evaluation kit cannot be programmed.

To re-program the device, use the `make erase` command on modus shell.

References

References

This user manual should be read in conjunction with the following documents available at [Product webpage](#):

- [1] Code examples: [Infineon GitHub repository](#)
- [2] Datasheet: [CYW20829, AIROC™ Bluetooth® LE 5.4 MCU](#)
- [3] User guide: [Eclipse IDE for ModusToolbox™ user guide](#)

Glossary

Glossary

API

Application Programming Interface

EVK

Evaluation Kit

GPIO

General Purpose Input/Output

HCI

Host controller interface

I2C

Inter-Integrated Circuit

IDE

Integrated Development Environment

JTAG

Joint Test Action Group

LE

Low Energy

LED

Light emitting diode

LPO

Low-power oscillator

MEMS

Micro electro-mechanical system

NTC

Negative Temperature Coefficient

PCB

Printed Circuit Board

SPI

Serial peripheral interface

SWD

Serial Wire Debug

Glossary

UART

Universal Asynchronous Receiver/Transmitter

USB

Universal Serial Bus

XTAL

Crystal oscillator

Revision history

Revision history

Document revision	Date	Description of changes
**	2024-02-07	Initial release.

Trademarks

All referenced product or service names and trademarks are the property of their respective owners.

Edition 2024-02-07

Published by

Infineon Technologies AG

81726 Munich, Germany

© 2024 Infineon Technologies AG.

All Rights Reserved.

Do you have a question about this document?

Email: erratum@infineon.com

Document reference

002-39356 Rev. **

Warnings

Due to technical requirements products may contain dangerous substances. For information on the types in question please contact your nearest Infineon Technologies office.

Except as otherwise explicitly approved by Infineon Technologies in a written document signed by authorized representatives of Infineon Technologies, Infineon Technologies' products may not be used in any applications where a failure of the product or any consequences of the use thereof can reasonably be expected to result in personal injury.

Mouser Electronics

Authorized Distributor

Click to View Pricing, Inventory, Delivery & Lifecycle Information:

[Infineon:](#)

[CYW920829B0M2P4TAI100EVK](#)