

## CSN Series Magnetoresistive (MR) Closed Loop Current Sensor

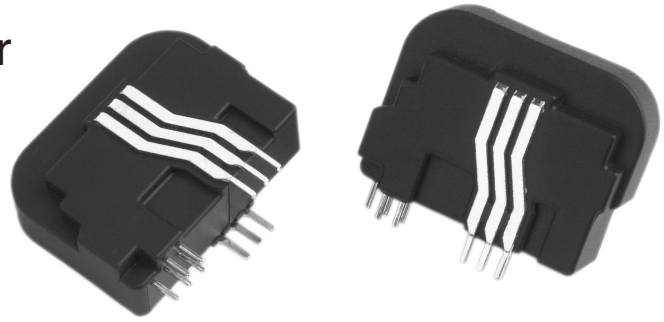

### Features

- Ultra low offset drift with temperature
- Unipolar voltage supply
- Superior global accuracy over temperature range -40 °C to 85 °C
- Customer adjustable gain
- Customer accessible voltage reference
- Self calibrating
- Designed for auto assembly
- Current output

### Typical applications

- Servo drives
- Variable speed drives
- Frequency converters
- Power supply systems
- Over current protection
- Uninterruptible power supplies UPS
- Power metering

The CSN Series MR current sensor builds on patented Honeywell technology to offer superior sensor performance and accuracy in current measuring applications.

The current sensor utilises an ASIC (Application Specific Integrated Circuit) and a magnetoresistive (MR) Honeywell magnetic sensor to provide extremely low offset drift with temperature resulting in stable, repeatable, accurate measurements. This is achieved by using an ASIC to exploit the unique features of the MR sensor. There is virtually no offset drift over the entire operating temperature range.

The sensor operates from a +5 V unipolar supply and has an accessible, internal 2.5 V voltage reference. The sensor can operate from either the internal voltage reference or an external voltage reference, thus enabling several sensors to be used without offset imbalance. Three primary pins enable the sensor to be configured for different measuring ranges and the current output signal enables different load resistors to be used depending on the application.

The sensor offers flexibility and performance to meet many applications.

### **WARNING** **PERSONAL INJURY**

DO NOT USE these products as safety or emergency stop devices, or in any other application where failure of the product could result in personal injury.

**Failure to comply with these instructions could result in death or serious injury.**

### **WARNING** **MISUSE OF DOCUMENTATION**

- The information presented in this product sheet (or catalogue) is for reference only. DO NOT USE this document as product installation information.
- Complete installation, operation and maintenance information is provided in the instructions supplied with each product.

**Failure to comply with these instructions could result in death or serious injury.**

# CSN Series MR Current Sensor

## Technical information

Supply voltage is +5 V and temperature is 25 °C unless otherwise stated

### Electrical

Nominal current (In)	25 A.t rms	
Measuring range	0 to ± 56 A.t <sup>[1]</sup>	
Measuring resistance <sup>[2]</sup> with +5 V	Rm min. 0 Ohm	Rm max. 80 Ohm
	@ ± 25 A.t rms	
	@ ± 40 A.t rms	31 Ohm
Nominal analogue output current	12.5 mA rms	
Turns ratio	1-2-3/2000	
Accuracy <sup>[3]</sup> @ 25 °C	max. ± 0.24 % @ In	
	@ -40 °C to 85 °C	max. ± 0.32 % @ In
Supply voltage	+5 Vdc (± 5 %)	
Internal reference voltage	+2.5 Vdc (± 10 mV)	
Galvanic isolation	5.0 kV rms/50 Hz/1 minute	

### Accuracy - dynamic performance

Zero offset current at 25 °C	< ± 30 uA (= 0.24 % of 25 A)
Thermal drift of offset current 10 °C to 50 °C	< ± 5 uA (= 0.04 % of 25 A)
Thermal drift of offset current -40 °C to 85 °C	< ± 10 uA (= 0.08 % of 25 A)
Linearity	< ± 0.1 %
Response time @ 90 % of pulse amplitude	< 200 ns
di/dt accurately followed	> 100 A/us
Bandwidth (-1 dB)	dc to 200 kHz

### General data

Operating temperature	-40 °C to 85 °C
Storage temperature	-40 °C to 90 °C
Current consumption	12 mA (+5 V) plus output current
Secondary internal resistance (@ 70 °C)	50 Ohm
Positive primary current	In direction of arrow
Sensor housing	Glass-filled Polyamide (UL94-V0)
Approvals	EN 50082-2, EN 50081-2, UL, CE
Rated insulation voltage (RIV)/Insulation classification	400 V reinforced
Dimensions [ L x W x H ] ( mm )	34 x 12,6 x 25,5
Construction	Fully encapsulated
Environment	Pollution degree 2, Category III
Fastening	PCB mounted sensor
Weight	20 g
Connection to primary	Via 6 x 0,8 mm square pins
Connection to secondary	Via 5 x 0,64 mm square pins

### Notes

<sup>[1]</sup> ac peak. Maximum dc or ac rms range is 40 A.t.

<sup>[2]</sup> Higher resistance (Rm) values can be used with reduced measuring range. Specified values conditional on 70 °C ambient and no power supply tolerance.

<sup>[3]</sup> Excludes the effects of tolerances of reference voltage and external load resistance.

# CSN Series MR Current Sensor

## Mounting drawing in mm and [inches]

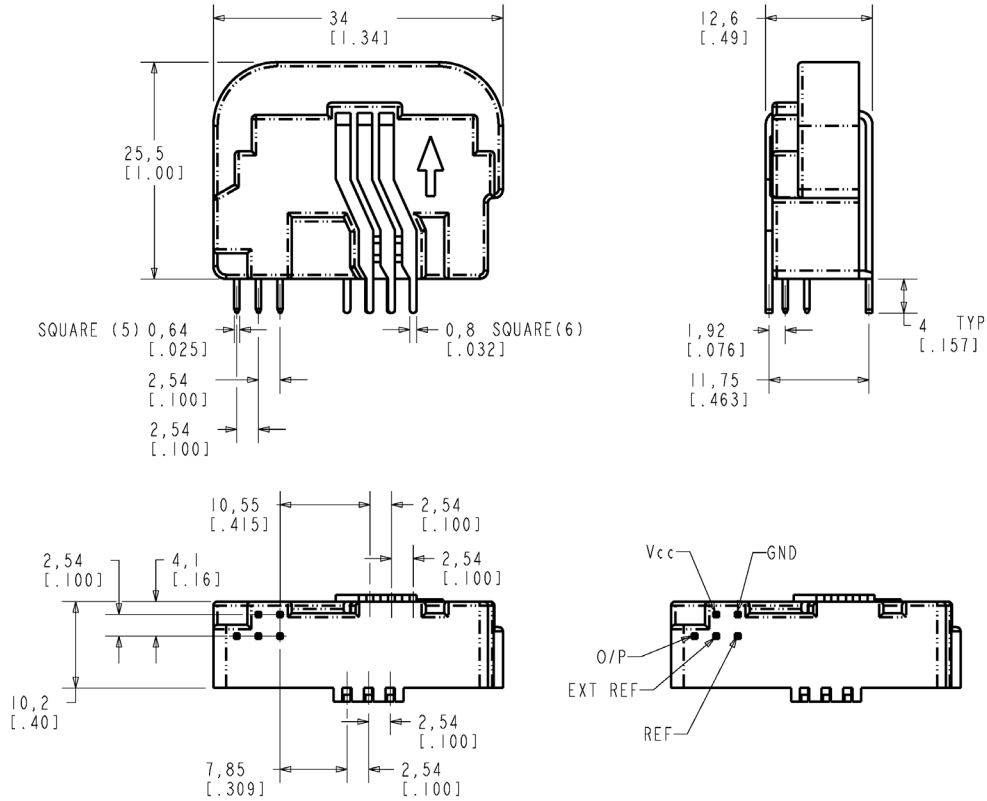

## Electrical wiring diagram

### Internal voltage reference mode

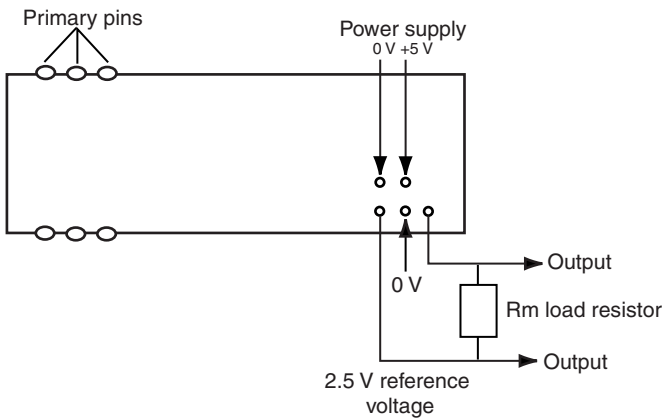

### External voltage reference mode

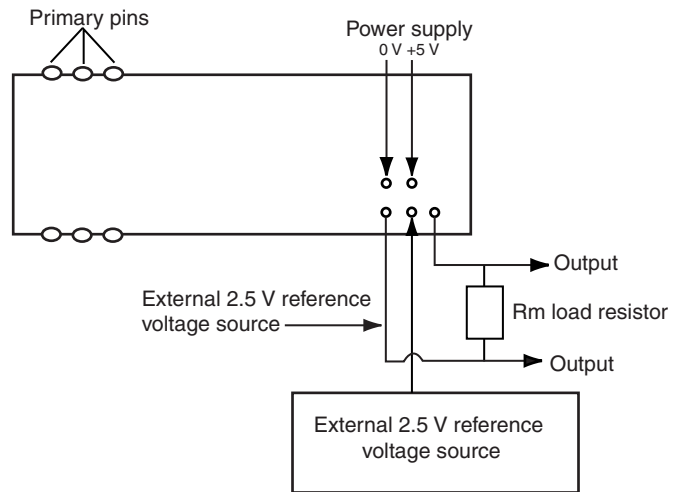

## Order guide

### Description

25 A MR current sensor

### Listing

CSNX25

# CSN Series MR Current Sensor

## Performance Parameter Definition

### Nominal Current

The maximum virtual value current can be measured in full temperature range. It was defined as  $A \cdot Ts$  (ampere\*turns) due to primary ampere effective was multiplied by primary turns and output current is proportional to ampere\*turns measured.

The current sensor is sensitive to the primary current linkage With  $N_p$ : the number of primary turns (1 to 3 depending upon the connection of the primary jumpers).

### Measuring Range

The maximum peak current can be measured in full temperature range, but not continually.

### Offset Current

The offset current can either be measured when the magnetic core of the transducer are:

- Completely demagnetized, and measure offset directly
- In known Magnetization state caused by a cycle current as below:

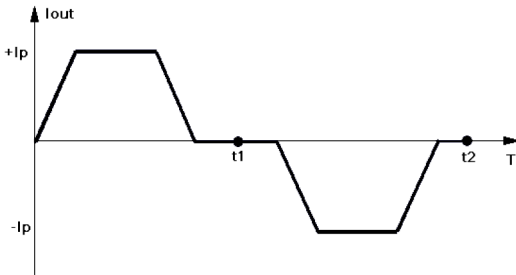

Using the current cycle as shown above, the offset was calculated as:

$$I_{\text{offset}} = (I_1 + I_2) / 2$$

$I_1$  = Output current at  $t_1$   
 $I_2$  = Output current at  $t_2$

### Residual current

Due to hysteresis of magnetic material used, the residual current  $I_M$  is the consequence of a current on the primary side and appears as an additional error of offset current. Using the current cycle same as above offset definition, the residual current can be calculated as:

$$I_{OM} = (I_1 - I_2) / 2$$

$I_1$  = Output current at  $t_1$   
 $I_2$  = Output current at  $t_2$

NOTE:  $I_{OM}$  depends on the current value  $I_p$ .

### Thermal Drift

The thermal drift of the offset current is the variation of the offset from 25 °C to the considered temperature:

$$I_{OT} = I_T - I_0$$

$I_T$  = Output current at temperature T without primary current  
 $I_0$  = Output current at temperature 25 °C without primary current

NOTE: all data are exclude residual current, the current sensor has to be demagnetized prior to the application of the current cycle (for example with a demagnetization tunnel).

### Response Time

The response time  $t_r$  is shown in the figure below. Response time is related with both product performance and primary current  $di/dt$ . So, they are measured at nominal ampere-turns and maximum  $di/dt$ .

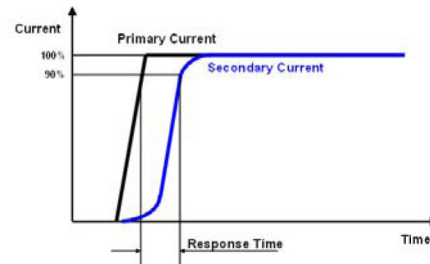

### Linearity

Increasing the primary current (DC) from 0 to  $I_p$ , then decreasing to 0; and then increasing to  $-I_p$  and back to 0, the step of increasing/decreasing is 10 % of  $I_p$ .

The linearity error  $\mathcal{E}_L$  was defined as the maximum difference between whether positive or negative measured points and the linear regression line, and expressed in % of  $I_p$ .

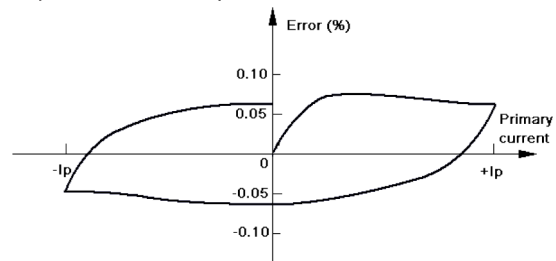

## Primary pin connections (3 turns)

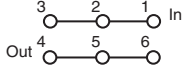
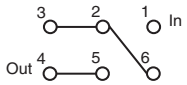
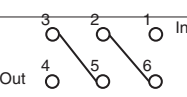
Primary turns	Primary Current		Nominal output (mA)	Primary pin connection
	Nom I <sub>pn</sub> (A)	Max I <sub>p</sub> (A)		
1	25	56	12.5	
2	12	27	12	
3	8	18	12	

### Warranty/Remedy

Honeywell warrants goods of its manufacture as being free of defective material and faulty workmanship. Contact your local sales office for warranty information. If warranted goods are returned to Honeywell during that period of coverage, Honeywell will repair or replace without charge those items it finds defective. **The foregoing is Buyer's sole remedy and is in lieu of all other warranties, expressed or implied, including those of merchantability and fitness for a particular purpose.**

While we provide application assistance, personally, through our literature and the Honeywell web site, it is up to the customer to determine the suitability of the product in the application.

Specifications may change at any time without notice. The information we supply is believed to be accurate and reliable as of this printing. However, we assume no responsibility for its use.

### Sales and Service

Honeywell serves its customers through a worldwide network of sales offices and distributors. For application assistance, current specifications, pricing or name of the nearest Authorised Distributor, contact your local sales office or:

#### TELEPHONE:

International: 1-815-235-6847  
 USA: 1-815-537-6945  
 Europe: +44 (0)1698 481 481  
 Asia Pacific: +65 6355-2828  
 Latin America: 1-305-805-8188

#### INTERNET:

[www.honeywell.com/sensing](http://www.honeywell.com/sensing)

This publication does not constitute a contract between Honeywell and its customers. The contents may be changed at any time without notice. It is the customer's responsibility to ensure safe installation and operation of the products. Detailed mounting drawings of all products illustrated are available on request.  
 © 2003 Honeywell International Inc. All Rights Reserved.

Sensing and Control

**Honeywell**

1985 Douglas Drive North  
 Golden Valley, MN 55422 USA

[www.honeywell.com](http://www.honeywell.com)

100452-4-EN IL50 GLO  
 June 2010

Copyright © 2010 Honeywell International Inc. All rights reserved.

**Honeywell**

# Mouser Electronics

Authorized Distributor

Click to View Pricing, Inventory, Delivery & Lifecycle Information:

[Honeywell:](#)

[CSNX25](#)