

Jun.1.2019 Copyright 2019 HIROSE ELECTRIC CO., LTD. All Rights Reserved.
 In case of consideration for using Automotive equipment / device which demand high reliability, kindly contact our sales window correspondents.

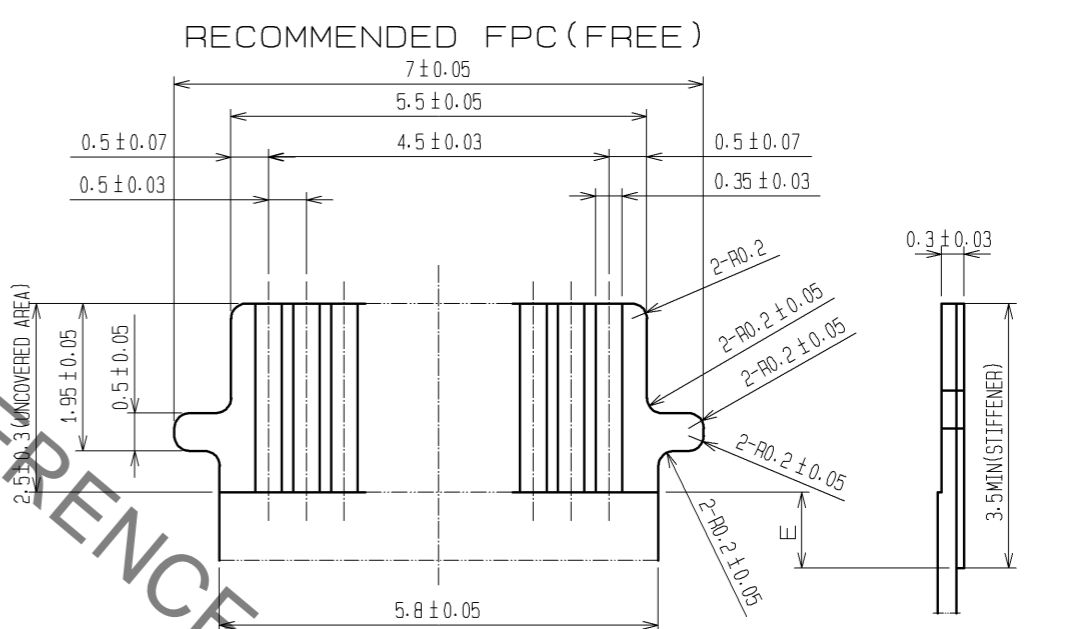
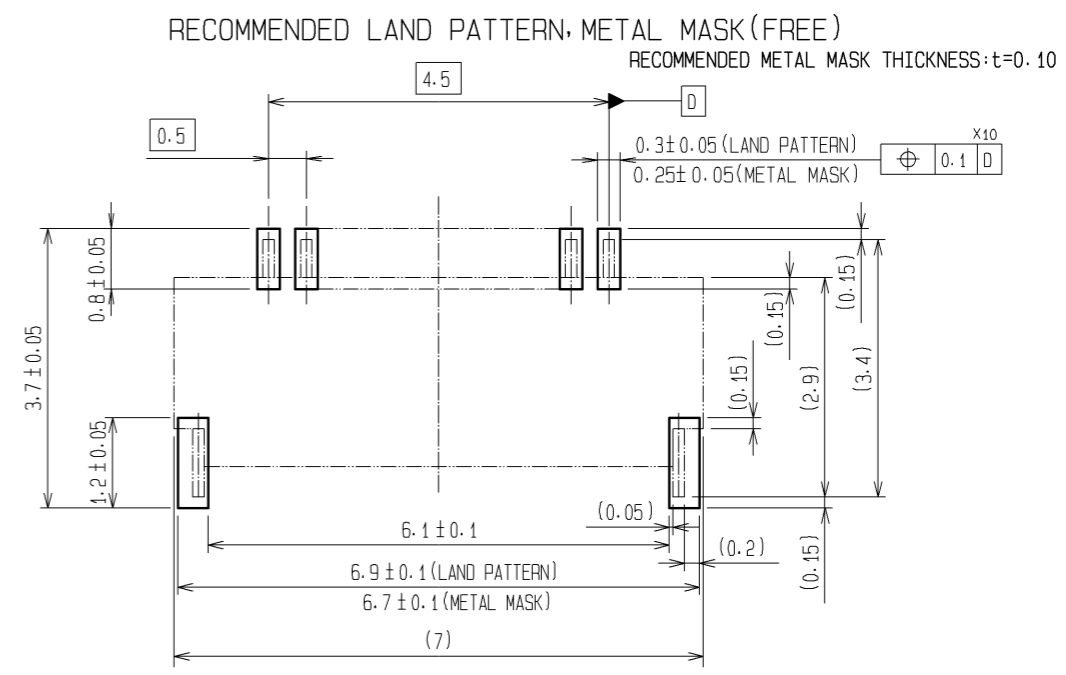
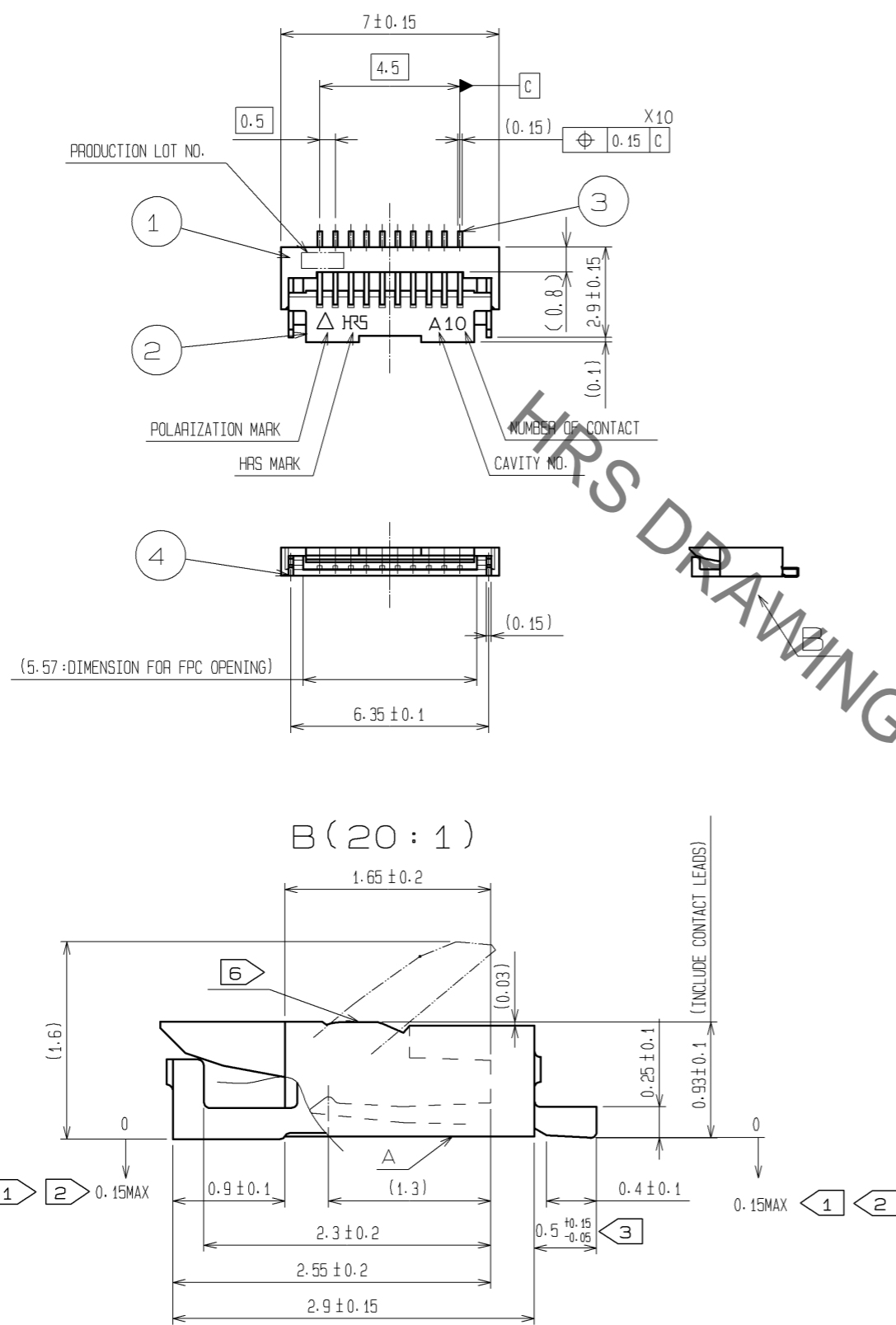

- NOTES
- ① LEAD CO-PLANARITY INCLUDING REINFORCED METAL FITTINGS SHALL BE 0.1 MAX.
 - ② DIMENSION: FROM REFERENCE A.
 - ③ DIFFERENCE OF EACH CONTACT LEAD TO BE MAX 0.1.
 - ④ TO BE DELIVERED WITH TAPE AND REEL PACKAGES.
 - ⑤ NOTE THAT PREVENTIVE HOLE FOR SINK MARK COULD BE ADDED FOR IMPROVEMENT.
 - ⑥ THE CONTACTS ARE PROTRUDED APPROX. 0.03mm FROM THE HOUSING TOP SURFACE.

FOR FPC APPLICATION, STIFFENER MATERIAL IS POLYIMID, HEAT CURED ADHESIVE.
 DIMENSION E MUST BE 0.5mm MINIMUM WHEN THE STIFFENER IS SHORTER THAN 3.5mm

4	PHOSPHOR BRONZE (PLATED MATERIAL)	TIN PLATING (REFLOW FINISHED) 1μm MIN OVER COPPER 0.5μm MIN						
3	PHOSPHOR BRONZE	(CONTACT AREA LEAD) GOLD PLATING 0.05μm MIN OVER NICKEL 1μm MIN (OTHER) NICKEL PLATING 1μm MIN	8	(CONNECTOR)				
2	PPS	BLACK	UL94V-0	6	POLYESTER			
1	LCP	BEIGE	UL94V-0	5	POLYSTYRENE			
NO.	MATERIAL	FINISH	REMARKS	NO.	MATERIAL	FINISH	REMARKS	
UNITS	mm	SCALE	5 : 1	COUNT	DESCRIPTION OF REVISIONS	DESIGNED	CHECKED	DATE
APPROVED		RI. TAKAYASU	08.08.26	DRAWING NO.		EDC3-157732-00		
CHECKED		TH. MURAI	08.08.26	PART NO.		FH19SD-10S-0.5SH		
DESIGNED		SI. MIZUSAWA	08.08.26	CODE NO.		CL580-2601-0-00		
DRAWN		SI. MIZUSAWA	08.08.26					

Jun.1.2019 Copyright 2019 HIROSE ELECTRIC CO., LTD. All Rights Reserved.
 In case of consideration for using Automotive equipment / device which demand high reliability, kindly contact our sales window correspondents.

EMBOSED CARRIER TAPE DIMENSIONS(2:1)

REEL DIMENSION (FREE)

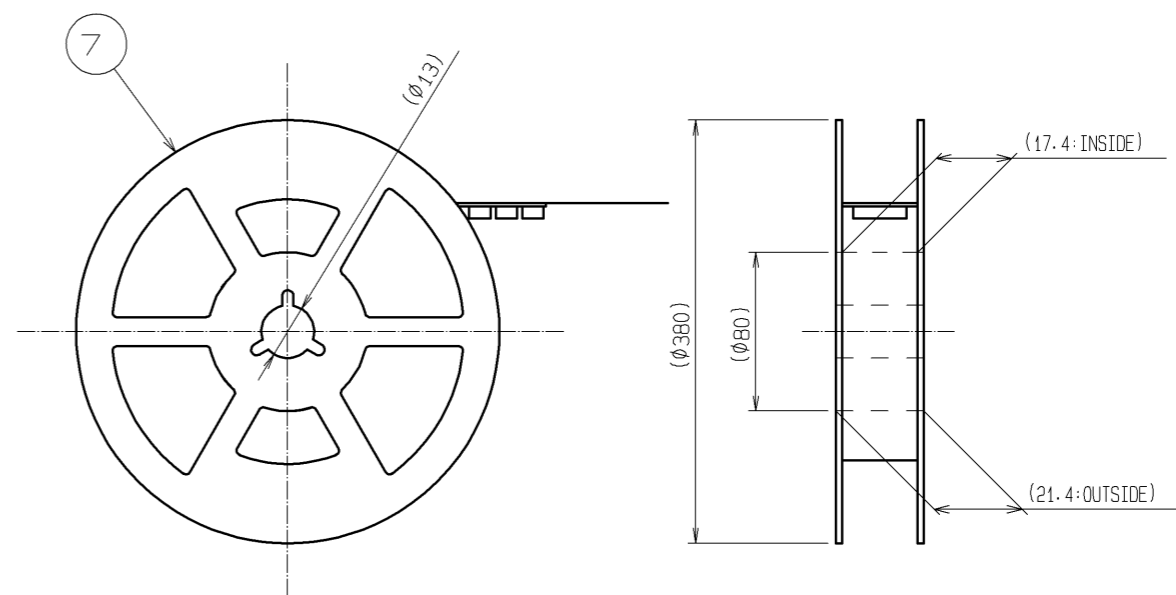
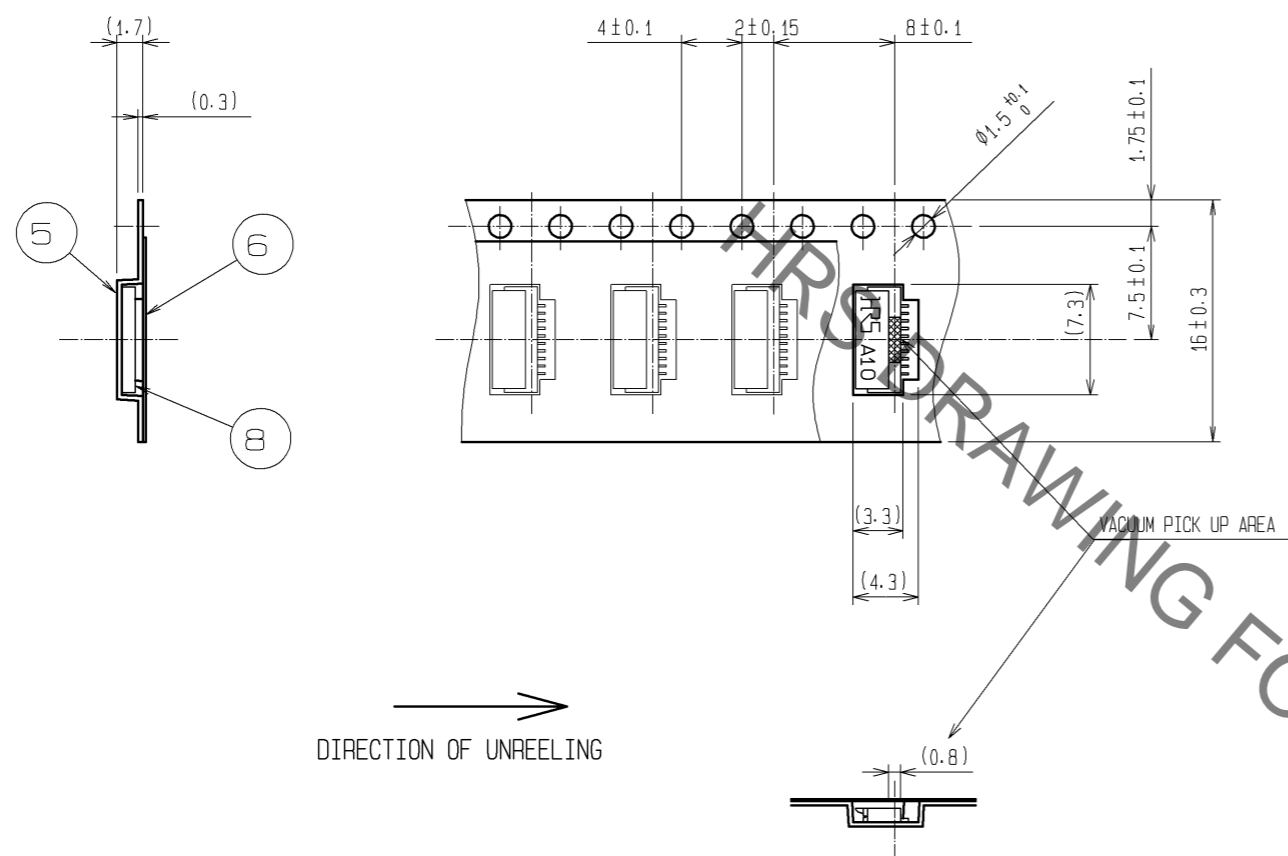

→
DIRECTION OF UNPEELING

HRS DRAWING FOR REFERENCE

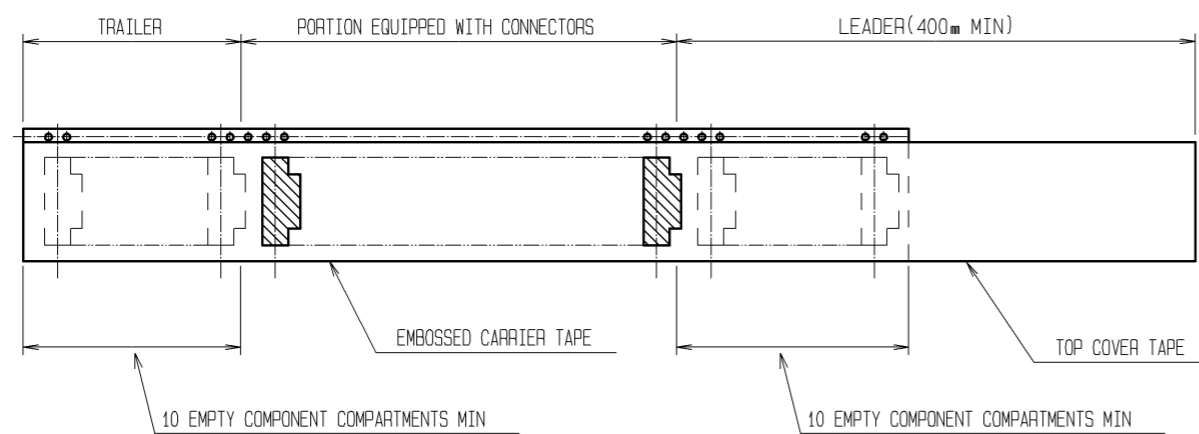

- NOTE 7 THE DIMENSIONS IN PARENTHESES ARE FOR REFERENCE.
 8 PER REEL : 5000 CONNECTORS.
 9 REFER TO JIS C 0806 (PACKAGING OF COMPONENTS FOR AUTOMATIC HANDLING.)

<DRAWING FOR PACKING>

HRS	DRAWING NO.	EDC3-157732-00	2/6
	PART NO.	FH19SD-10S-0.5SH	
	CODE NO.	CL580-2601-0-00	

Jun.1.2019 Copyright 2019 HIROSE ELECTRIC CO., LTD. All Rights Reserved.
In case of consideration for using Automotive equipment / device which demand high reliability, kindly contact our sales window correspondents.

This connector is small and thin and requires delicate and careful handling.
Read through the instructions shown below and handle the connector properly.
Each values indicating here are for reference and may differ from standard value.

[INSTRUCTIONS FOR MOUNTING ON THE BOARD]

◆Warp of Board

Minimize warp of the board as much as possible.
Lead co-planarity including reinforced metal fittings is 0.1 mm or less.
Too much warp of the board may result in a soldering failure.

◆Load to Connector

Do not apply a force of 1 N or more to the connector before mounting it on the board.
Otherwise, the connector may be broken.
Do not insert the FPC or operate the connector before mounting it.

◆Load to Board

•Splitting a large board into several pieces
•Screwing the board
Avoid the handling described above so that no force is exerted on the board during the assembly process.
Otherwise, the connector may become defective.

◆Amount of Warp

The warp of a 100mm wide board should be 1 mm or less.
The warp of board suffers stress on connector and the connector may become defective.

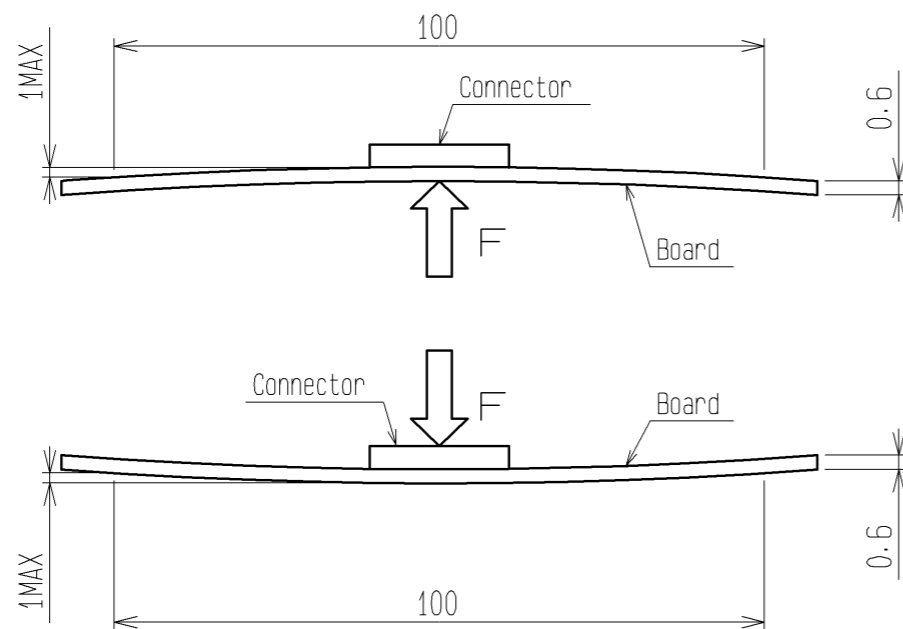

[INSTRUCTIONS ON INSERTING FPC AND CONNECTION]

◆ Use of the actuator

1. Be very careful not to apply excessive force when releasing the actuator in the initial position (with no FPC inserted).
If you use your nail or finger or pair of tweezers as shown below, the terminals may be deformed.

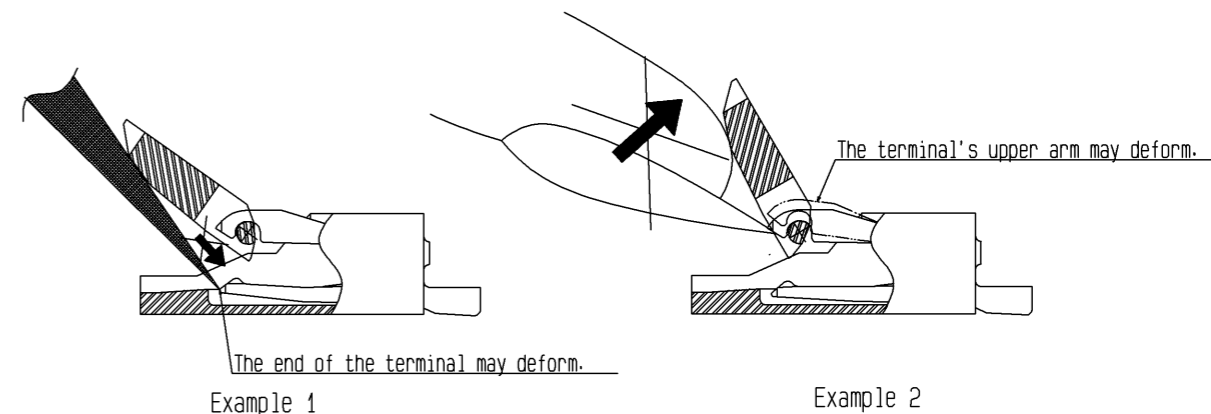

2. When operating the actuator, do not apply a force in the direction of the connector. The actuator may get pushed into the connector, causing damage to the connector.

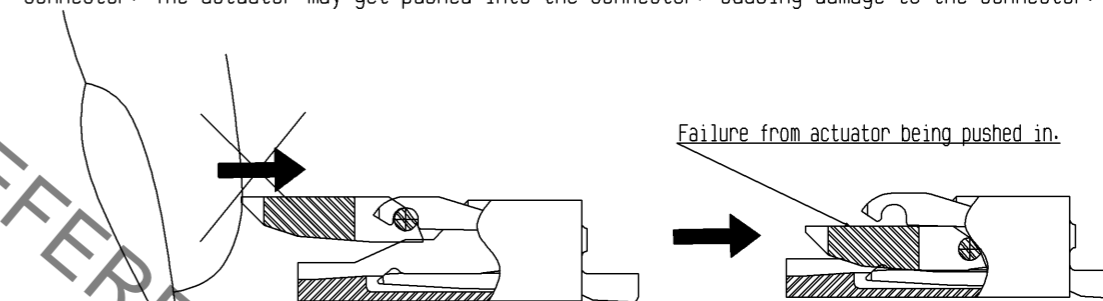

The actuator is designed to rotate on the axis shown in the figure below so make sure to use a rotating motion when operating it.

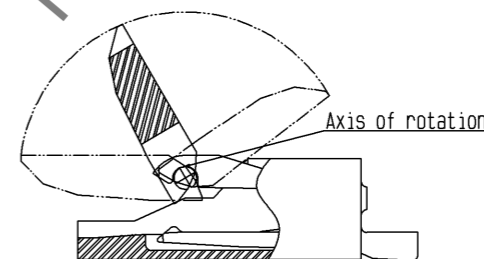

<INSTRUCTION MANUAL>

HRS	DRAWING NO.	EDC3-157732-00
	PART NO.	FH19SD-10S-0.5SH
	CODE NO.	CL580-2601-0-00
		△ 3/6

Jun.1.2019 Copyright 2019 HIROSE ELECTRIC CO., LTD. All Rights Reserved.
In case of consideration for using Automotive equipment / device which demand high reliability, kindly contact our sales window correspondents.

3. The actuator is not designed to open more than 130 degrees, so do not push it back further than this. Doing so may result in deformed terminals, actuator break-off or other damage.

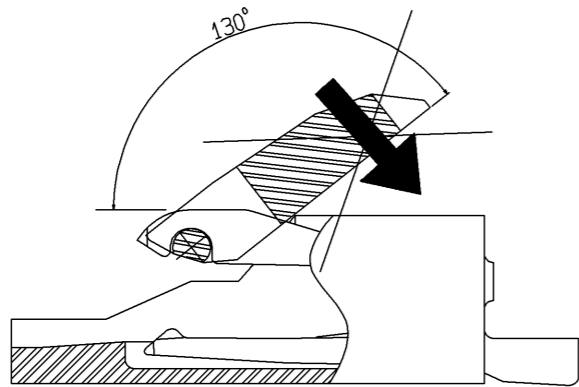

4. When operating the actuator, avoid operating it at its end. Make sure to operate it at its middle section.

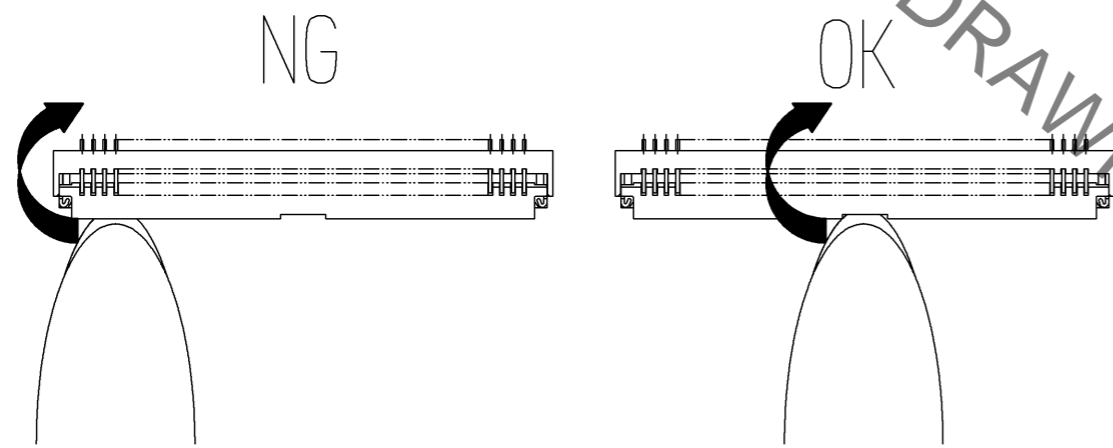

5. Do not lift or snag the actuator as shown in the figures below. This can result in damage. (Operate the actuator only in a rotating fashion as instructed in paragraph 2 above.)

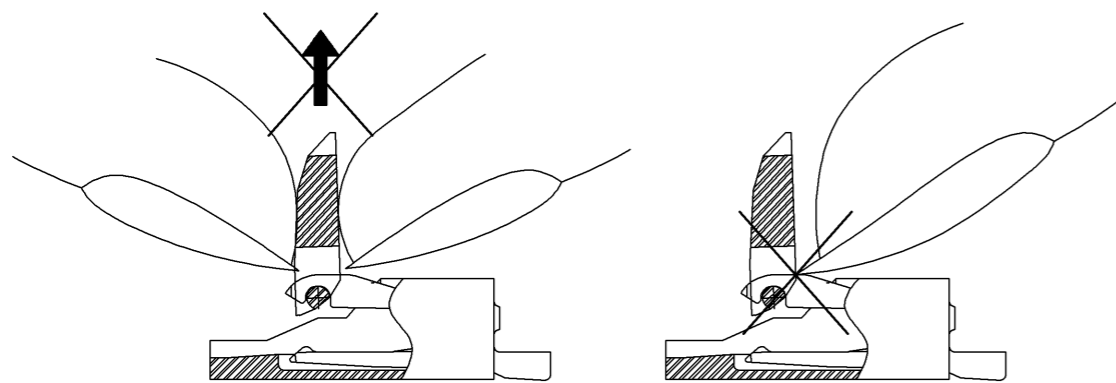

◆ Contact orientation

This connector is configured with its contacts at the bottom. Therefore, insert the FPC with the side with the exposed conductors facing down.

◆ Inserting an FPC

1. Insert the FPC by about 15 degrees along the surface and at a right angle to the connector. Insert it properly to the very end. If the FPC is inserted at a slant (incorrectly), the conductors may short-circuit due to pitch shift or the edge of the FPC may catch in the terminals, resulting in deformation of the terminals.

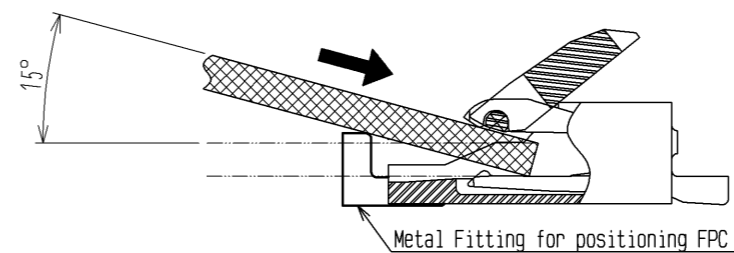

2. When inserting the FPC, make sure not to bump the FPC's tip against the upper arm area of the terminal. This may cause the terminal to deform.

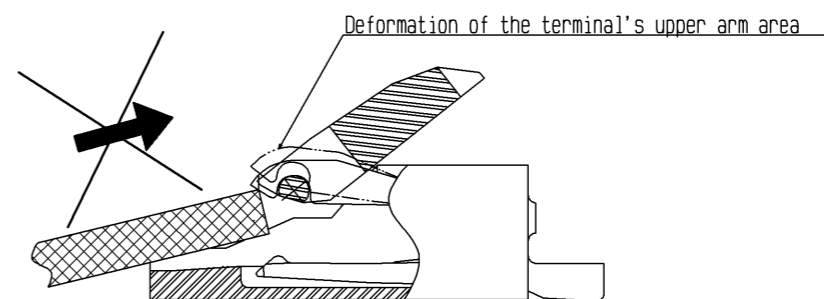

3. Do not insert the FPC diagonally from above. If the FPC is inserted at a slant (incorrectly) as shown below in the FPC insertion process, the FPC may bend and patterns may break or the FPC may not insert completely, resulting in improper conduction.

※Keep a sufficient FPC insertion space in the stage of the layout in order to avoid incorrect FPC insertion. Besides, it is not difficult to insert FPC correctly all the way to the end. Design the proper layout of parts.

※Make adjustments with the FPC manufacturer for FPC bending performance and wire breakage.

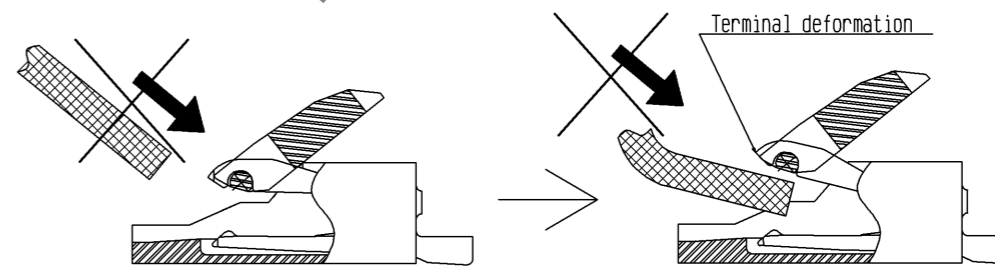

<INSTRUCTION MANUAL>

HRS	DRAWING NO.	EDC3-157732-00
	PART NO.	FH19SD-10S-0.5SH
	CODE NO.	CL580-2601-0-00
		△ 4/6

Jun.1.2019 Copyright 2019 HIROSE ELECTRIC CO., LTD. All Rights Reserved.
In case of consideration for using Automotive equipment / device which demand high reliability, kindly contact our sales window correspondents.

4. When inserting (or removing) an FPC using a pair of tweezers, once the tip of the FPC is inside the connector, do not hold the FPC at an area above the connector (higher than 1mm from the board), twist the FPC or apply upward force. The upper arm area of the terminal will deform and compromise reliability.

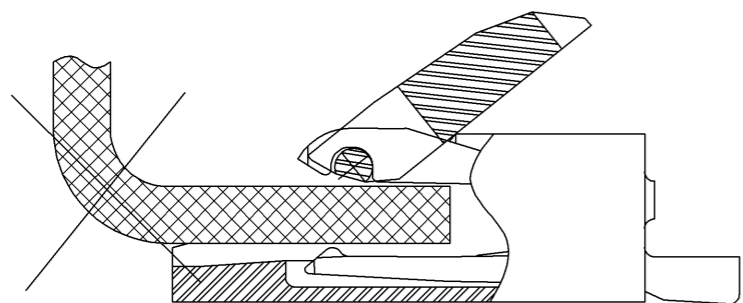

5. Do not rotate the actuator when FPC TAB is on Metal Fittings. Make sure the position of FPC TAB and Metal Fittings before rotate the actuator.

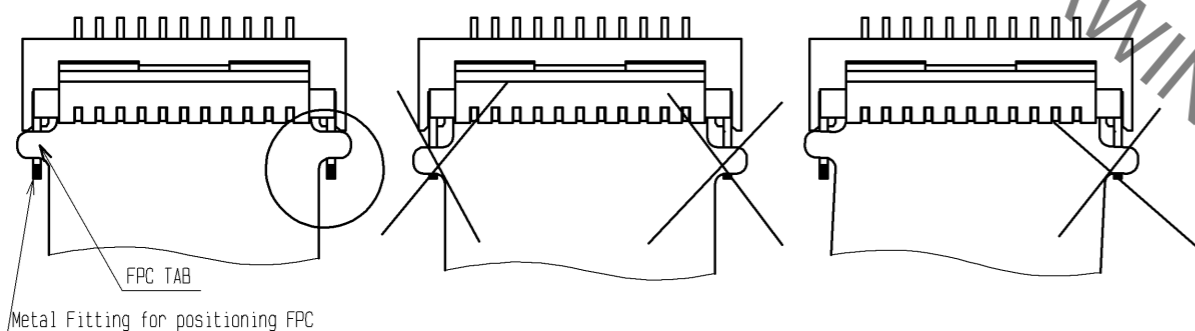

◆ Confirming the state of the lock
Once it is locked, make sure that the actuator is parallel to the board.
However, if the actuator approaches 0 degrees, make sure that it is not.

[Reminders on FPC routing after it has been connected]

◆ Loads applied to the FPC
Once the FPC is attached, make sure that it is not subjected to loads. This can cause the connector lock to disengage, or cause a discontinuation or damage to the FPC. If the FPC is subjected to a constant load, fasten the FPC in place. When routing the FPC, make sure that it is not forced to make a tight bend at the FPC connection.

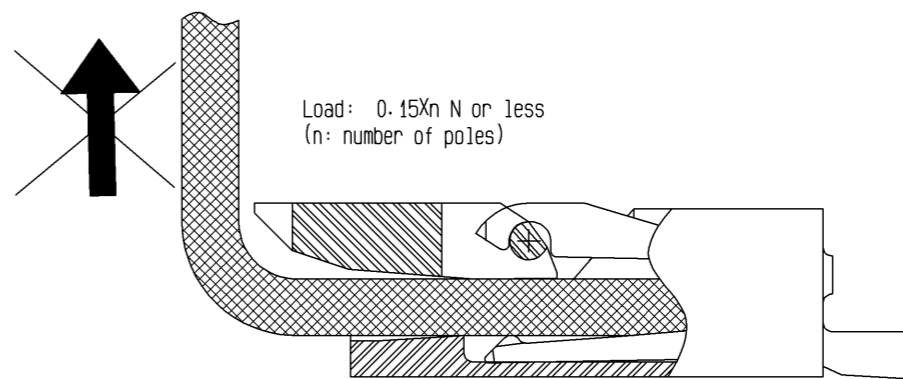

[Reminders on releasing the lock]

◆ Operating the actuator
1. Do not operate the end of the actuator as shown in the photo on the left below when releasing the lock. This can cause damage to the actuator.
Always operate the middle area of the actuator as shown in the photo on the right when operating the lock.

[Reminders on operating the lock]

◆ Actuator operation
Once the FPC is attached, do not operate the end of the actuator as shown in the photo on the left below to close the lock. This can cause damage to the actuator.
Always operate the middle area of the actuator as shown in the photo on the right when operating the lock.

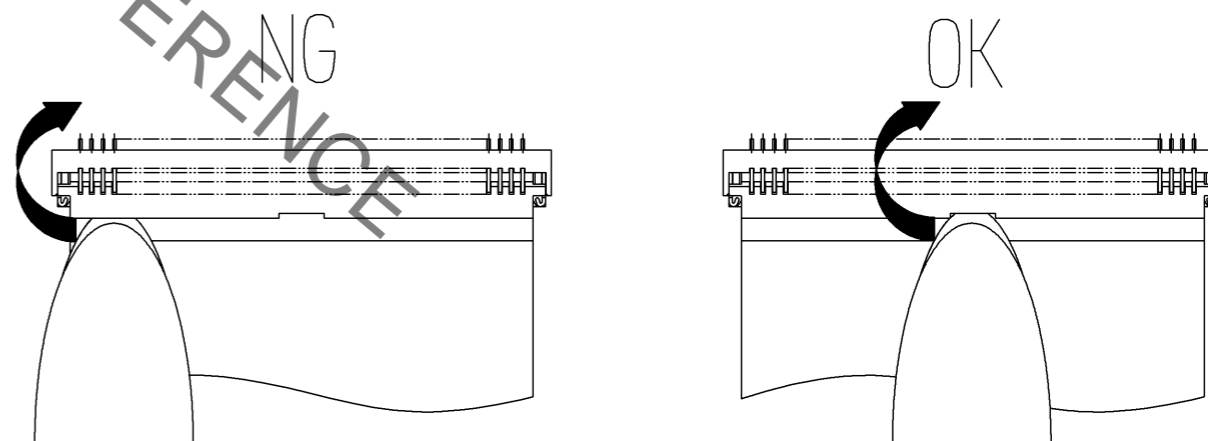
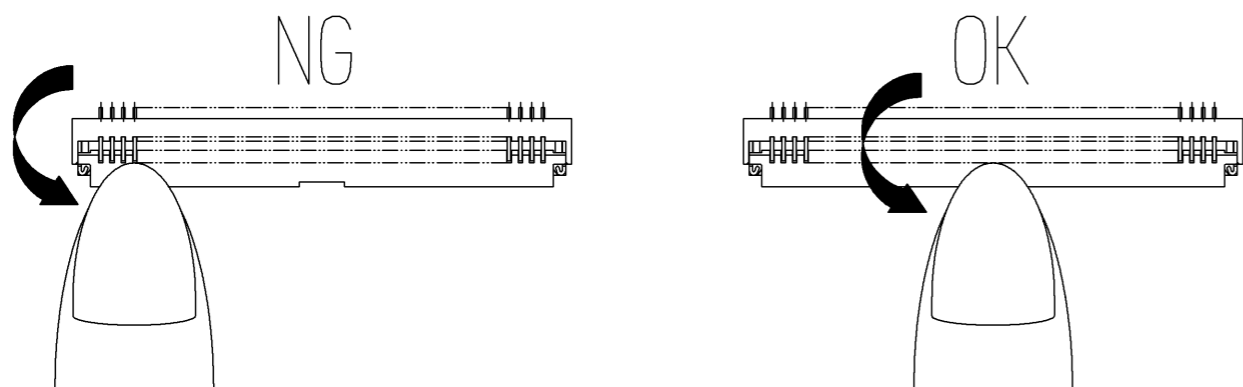

<INSTRUCTION MANUAL>

HRS	DRAWING NO.	EDC3-157732-00
	PART NO.	FH19SD-10S-0.5SH
	CODE NO.	CL580-2601-0-00
		△ 5/6

2. When opening a actuator that is in its locked state (FPC is inserted), take special care not to apply excessive force. Inserting a fingernail or pair of tweezers deeply, as shown in the figure below, may result in deformed terminals.

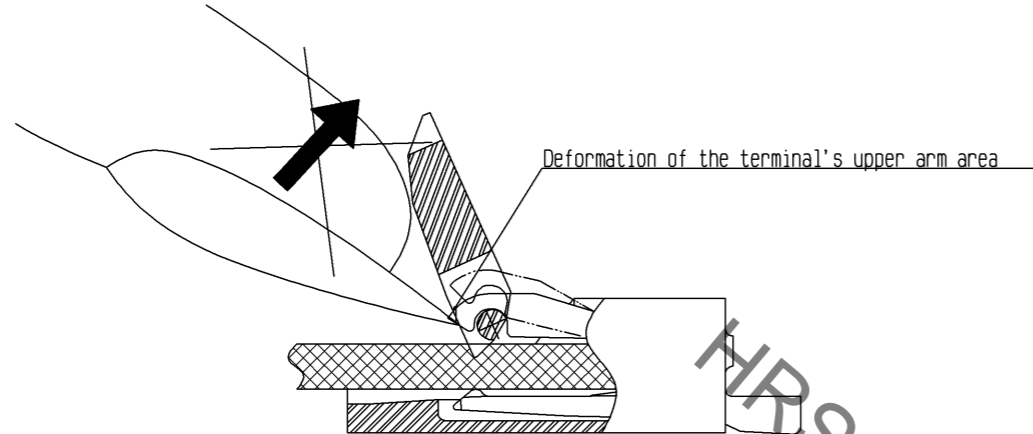

[Other reminders]

- ◆ Reminders on manual soldering
 1. Do not perform reflows or manual soldering with an FPC inserted in the connector.
 2. Do not apply excessive heat or allow the soldering iron to touch areas other than the connector's leads. This can cause the connector to deform or melt.
 3. Do not use excessive solder (flux).
 When too much solder (flux) is used, it can attach to the contacts or the actuator's rotation shaft and cause contact failure or faulty actuator rotation.
 Additionally, make sure not to use excessive solder on the reinforcement hardware.
 This may interfere with the actuator's rotation and cause connector damage.

[Reminders on removing the FPC]

- ◆ To remove the FPC, always make sure that the actuator has been fully released. Do not pull the FPC straight up or at an angle while it is still in the connector. This may cause the upper arm area of the terminal to deform and cause contact failure.

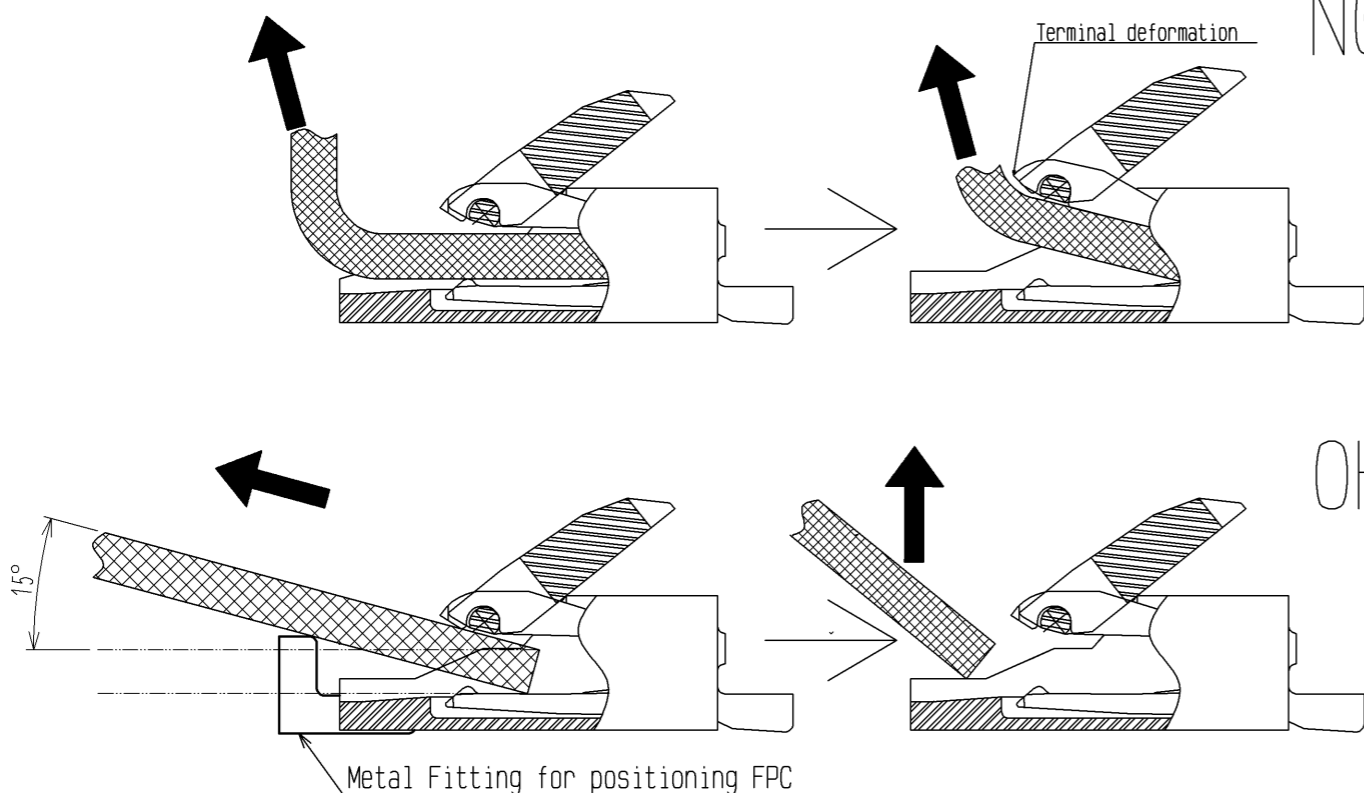

HRS DRAWING FOR REFERENCE

<INSTRUCTION MANUAL>

HRS	DRAWING NO.	EDC3-157732-00
	PART NO.	FH19SD-10S-0.5SH
	CODE NO.	CL580-2601-0-00
		△ 6/6

Mouser Electronics

Authorized Distributor

Click to View Pricing, Inventory, Delivery & Lifecycle Information:

[Hirose Electric:](#)

[FH19SD-10S-0.5SH](#)