

Sep.1.2021 Copyright 2021 HIROSE ELECTRIC CO., LTD. All Rights Reserved.
In case of consideration for using Automotive equipment / device which demand high reliability, kindly contact our sales window correspondents.

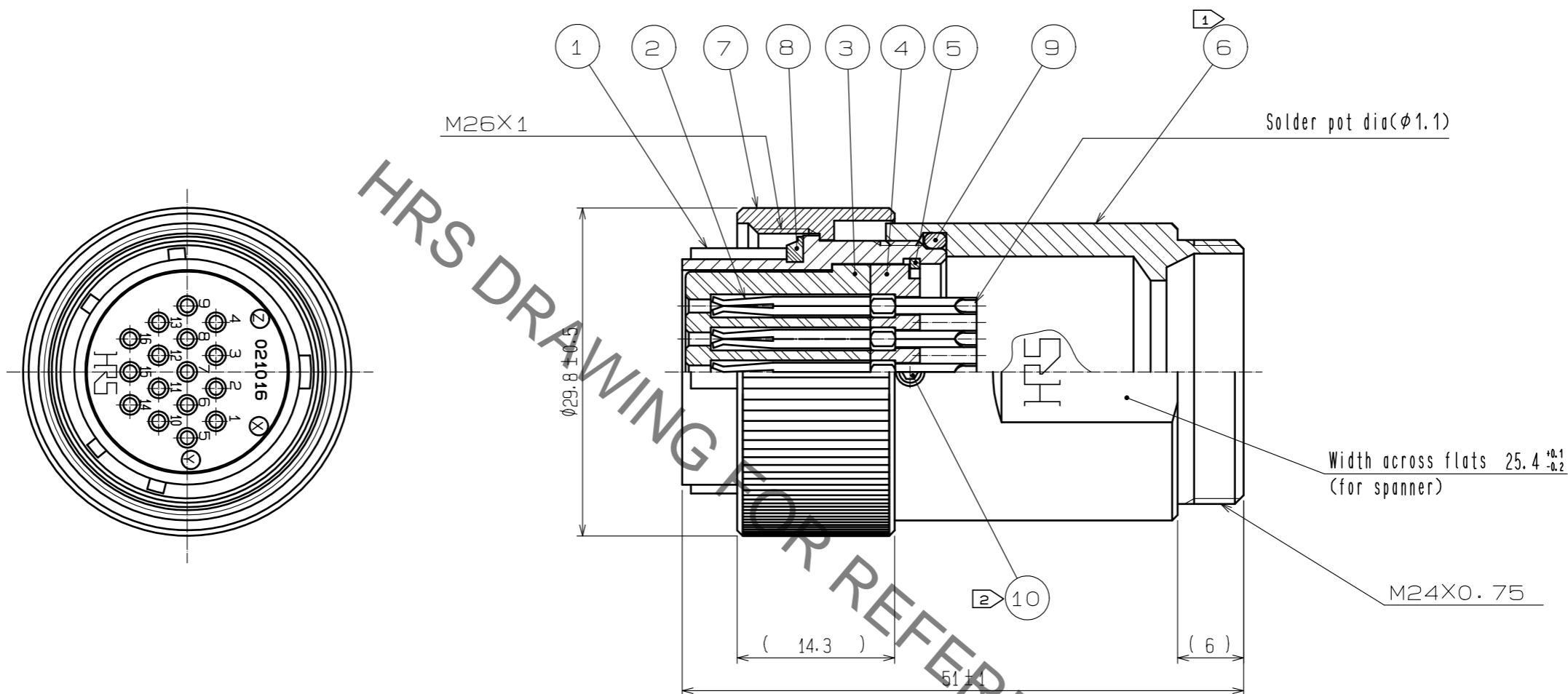

- NOTES
- ① The recommended tightening torque of Ref No. ⑥ : 4 to 4.5 N·m.
 - ② The recommended tightening torque of Ref No. ⑩ : 0.2 to 0.25 N·m.
 - ③ One example of the rotation of REF. No. ⑥ to REF. No. ① is shown.
 - ④ LOCTITE 263 HENKEL JAPAN or equivalent is recommended to prevent REF. No. ①, ⑥ and ⑩ for loosening.
 - ⑤ This products to be used with cable clamp, JR21WCC-※
※Designate diameter(mm) of applicable cable.
 - ⑥ The cable pull and twisting strength, waterproof tightness and other characteristics may differ, depending on the cable structure.
Please confirm before the use.

NO.	MATERIAL	FINISH . REMARKS	NO.	MATERIAL	FINISH . REMARKS
5	PHOSPHOR BRONZE	NICKEL PLATING	10	STAINLESS STEEL	HEX SOCKET SET SCREW HEX : 1.27
4	PHENOL FORMALDEHYDE	(BLACK) UL94V-0	9	ACRYLONITRILE BUTADIENE RUBBER	(BLACK)
3	PHENOL FORMALDEHYDE	(BLACK) UL94V-0	8	ACRYLONITRILE BUTADIENE RUBBER	(BLACK)
2	COPPER ALLOY	SILVER PLATING 2μm min	7	BRASS	BLACK CHROME PLATING
1	ALUMINUM ALLOY	BLACK CHROME PLATING	6	BRASS	BLACK CHROME PLATING

UNITS	SCALE	COUNT	DESCRIPTION OF REVISIONS	DESIGNED	CHECKED	DATE
mm	2 : 1	△				
APPROVED : HY. KOBAYASHI			18.02.26	DRAWING NO. EDC-110572-31-00		
CHECKED : HY. KOBAYASHI			18.02.26	PART NO. JR21WP-16S(31)		
DESIGNED : TH. KAMEYA			18.02.23	CODE NO. CL114-2017-5-31		
DRAWN : MK. INOUE			18.02.23	1/1		

Mouser Electronics

Authorized Distributor

Click to View Pricing, Inventory, Delivery & Lifecycle Information:

[Hirose Electric:](#)

[JR21WP-16S\(31\)](#)