

Sep.1.2021 Copyright 2021 HIROSE ELECTRIC CO., LTD. All Rights Reserved.
In case of consideration for using Automotive equipment / device which demand high reliability, kindly contact our sales window correspondents.

COUNT	DESCRIPTION OF REVISIONS	BY	CHKD	DATE	COUNT	DESCRIPTION OF REVISIONS	BY	CHKD	DATE

A - A

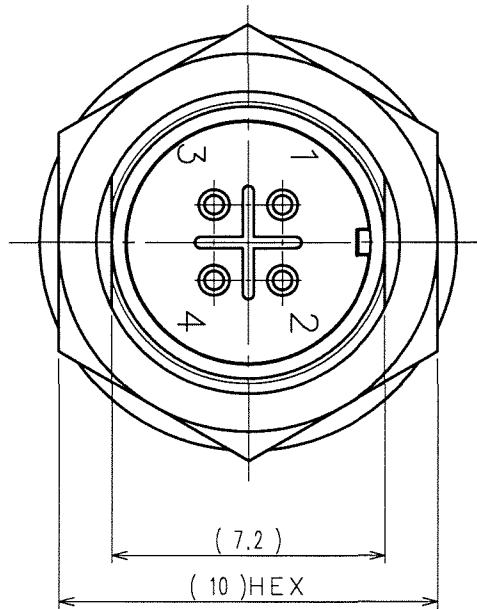
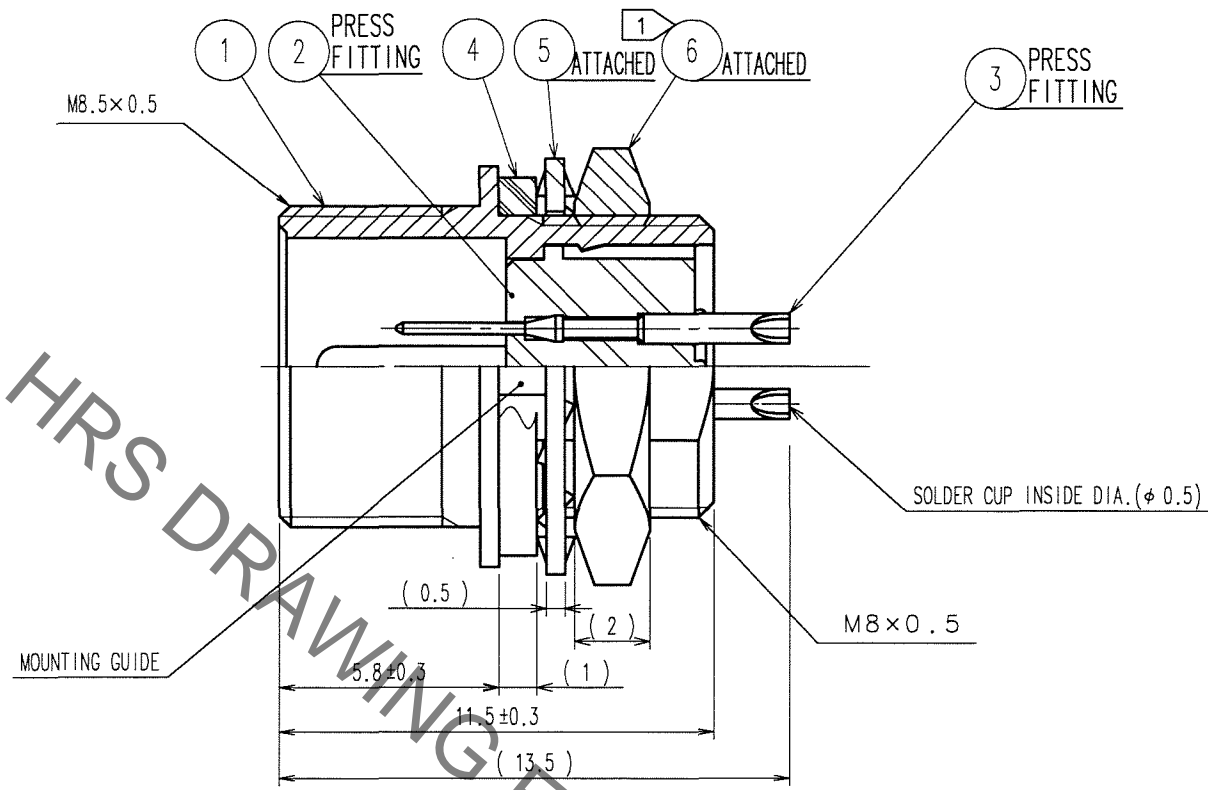
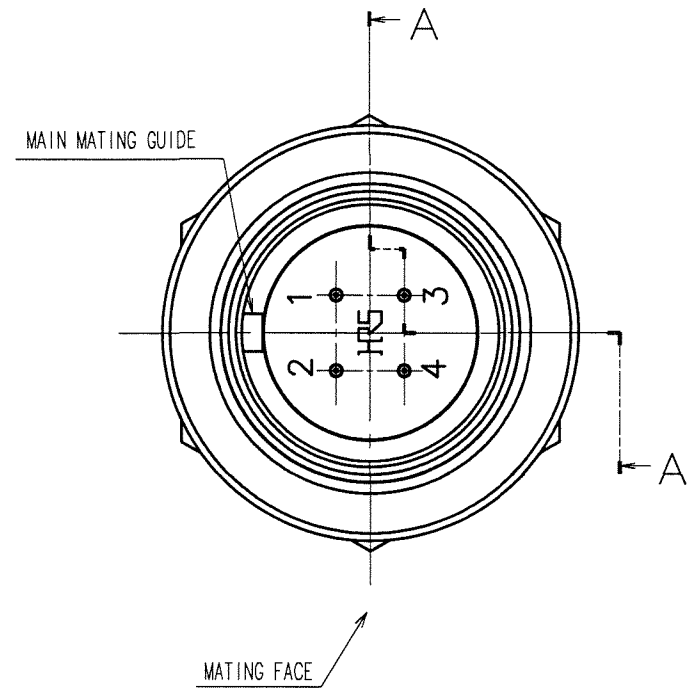

PANEL CUTOUT FROM MATING FACE
PANEL THICKNESS: 0.7 TO 2

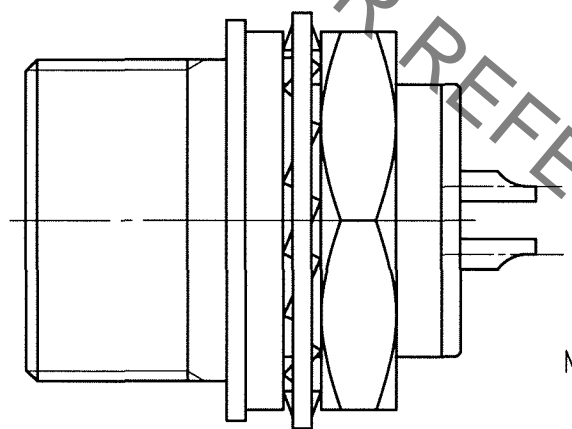
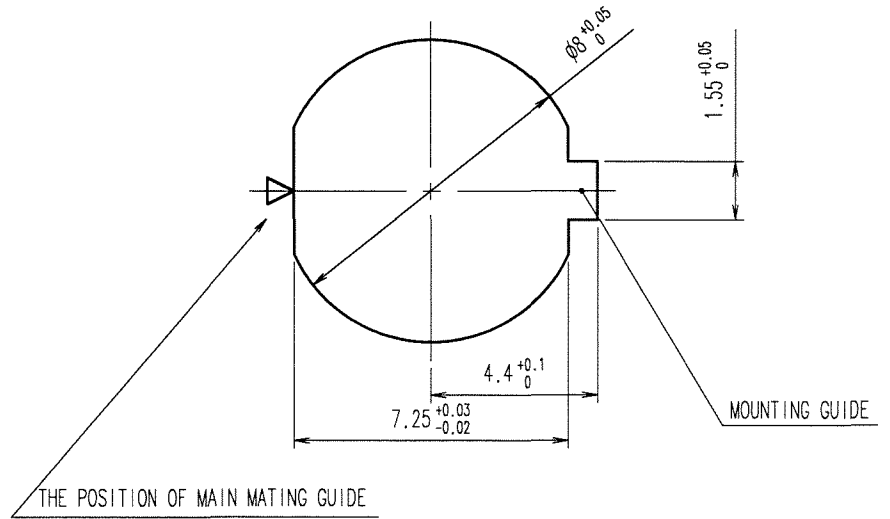

- NOTES
- ① THE RECOMMENDED TIGHTENING TORQUE OF REF. No. ⑥ TO BE 1 N·m. COATING WITH LOCTITE 242 MANUFACTURED BY HENKEL JAPAN OR EQUIVALENT IS RECOMMENDED TO PREVENT LOOSENESS.
 - ② OVER PLATING : GOLD 0.2μm min.
UNDER PLATING : NICKEL 2μm min.

3	PHOSPHOR BRONZE	②	6	BRASS	NICKEL PLATING
2	POLYPHENYLENE SULFIDE	(BLACK) UL94V-0	5	PHOSPHOR BRONZE	NICKEL PLATING
1	ZINC ALLOY	NICKEL PLATING	4	ETHYLENE PROPYLENE RUBBER	(BLACK)
NO.	MATERIAL	FINISH, REMARKS	NO.	MATERIAL	FINISH, REMARKS

CODE NO. (OLD)	DRAWN	DESIGNED	CHECKED	APPROVED	RELEASED
CL	H. Kawashima	H. Kawashima	E. Kunii	M. Sato	
	06.10.18	06.10.18	06.10.18	06.10.19	

SCALE	DRAWING NO.	PART NO.
5 : 1	EDC3-110175-73	HR25-7TR-4P(73)
UNITS	HIROSE ELECTRIC CO., LTD	CODE NO.
mm		CL125-0008-7-73

TO
R

Mouser Electronics

Authorized Distributor

Click to View Pricing, Inventory, Delivery & Lifecycle Information:

[Hirose Electric:](#)

[HR25-7TR-4P\(73\)](#)