

Sep.1.2021 Copyright 2021 HIROSE ELECTRIC CO., LTD. All Rights Reserved.
In case of consideration for using Automotive equipment / device which demand high reliability, kindly contact our sales window correspondents.

| COUNT | DESCRIPTION OF REVISIONS | BY | CHKD | DATE | COUNT | DESCRIPTION OF REVISIONS | BY | CHKD | DATE |
|-------|--------------------------|-----|------|----------|-------|--------------------------|----|------|------|
| 1 | DIS-C-000585 | T.K | E.K | 07.07.27 | | | | | |

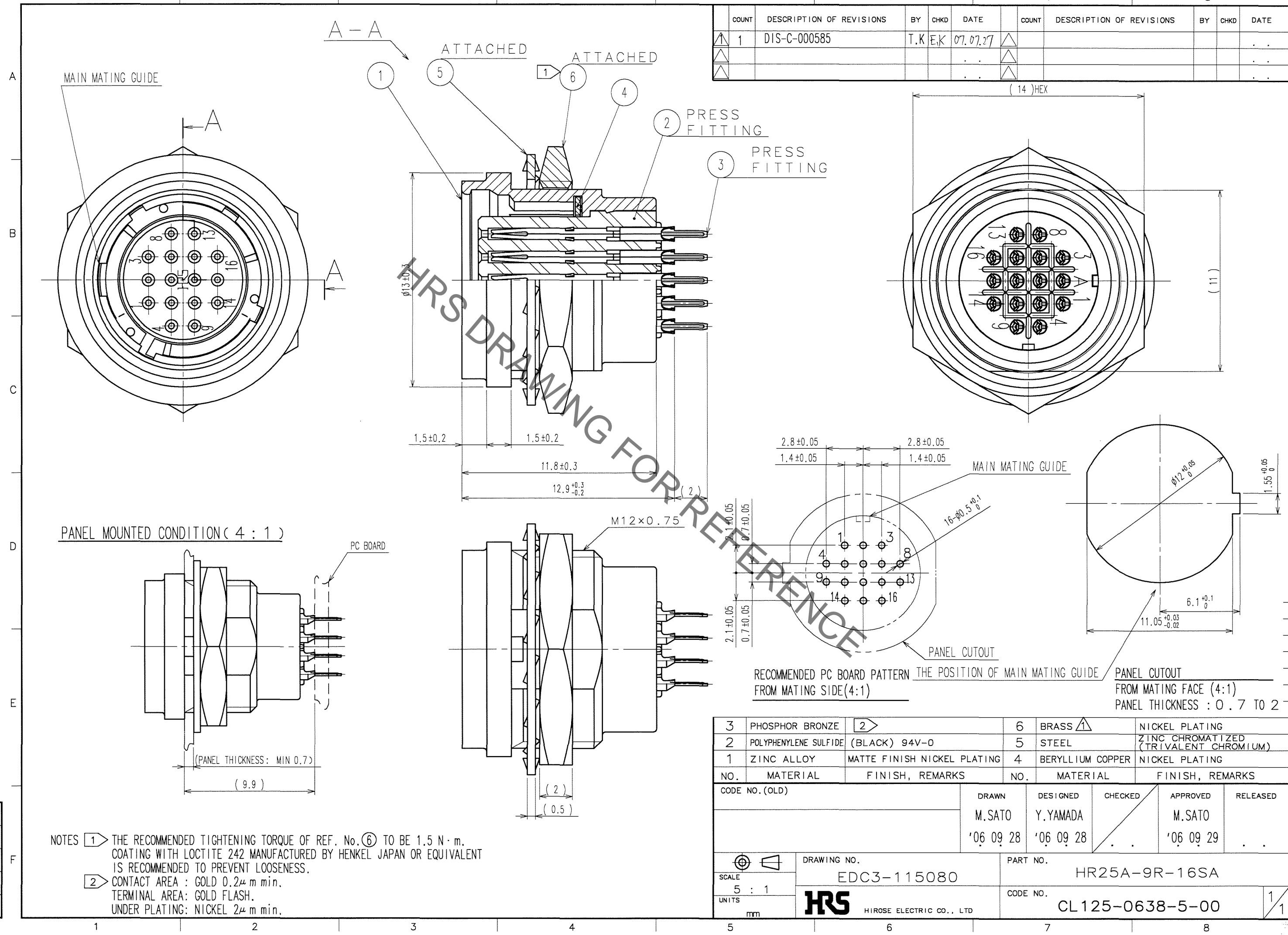

HRS DRAWING FOR REFERENCE

| NO. | MATERIAL | FINISH, REMARKS | NO. | MATERIAL | FINISH, REMARKS |
|-----|-----------------------|-----------------------------|-----|------------------|---------------------------------------|
| 3 | PHOSPHOR BRONZE | 2 | 6 | BRASS | NICKEL PLATING |
| 2 | POLYPHENYLENE SULFIDE | (BLACK) 94V-0 | 5 | STEEL | ZINC CHROMATIZED (TRIVALENT CHROMIUM) |
| 1 | ZINC ALLOY | MATTE FINISH NICKEL PLATING | 4 | BERYLLIUM COPPER | NICKEL PLATING |

| CODE NO. (OLD) | DRAWN | DESIGNED | CHECKED | APPROVED | RELEASED |
|----------------|-----------|-----------|---------|-----------|----------|
| | M.SATO | Y.YAMADA | | M.SATO | |
| | '06 09 28 | '06 09 28 | | '06 09 29 | |

| | | |
|----------------|---------------------------------|-----------------------------|
| SCALE 5 : 1 | DRAWING NO. EDC3-115080 | PART NO. HR25A-9R-16SA |
| UNITS mm | HRS HIROSE ELECTRIC CO., LTD | CODE NO. CL125-0638-5-00 |

NOTES

- THE RECOMMENDED TIGHTENING TORQUE OF REF. No. ⑥ TO BE 1.5 N·m. COATING WITH LOCTITE 242 MANUFACTURED BY HENKEL JAPAN OR EQUIVALENT IS RECOMMENDED TO PREVENT LOOSENESS.
- CONTACT AREA : GOLD 0.2μm min.
TERMINAL AREA: GOLD FLASH.
UNDER PLATING: NICKEL 2μm min.

| |
|----|
| TO |
| R |
| |
| |

Mouser Electronics

Authorized Distributor

Click to View Pricing, Inventory, Delivery & Lifecycle Information:

[Hirose Electric:](#)

[HR25A-9R-16SA](#)