

Sep.1.2021 Copyright 2021 HIROSE ELECTRIC CO., LTD. All Rights Reserved.
In case of consideration for using Automotive equipment / device which demand high reliability, kindly contact our sales window correspondents.

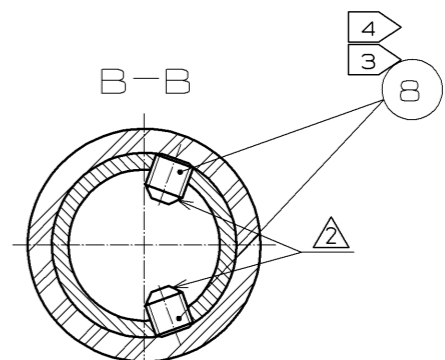
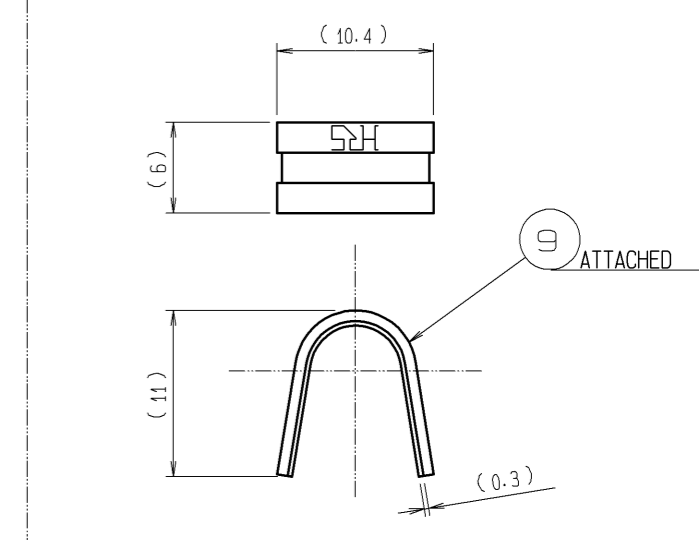
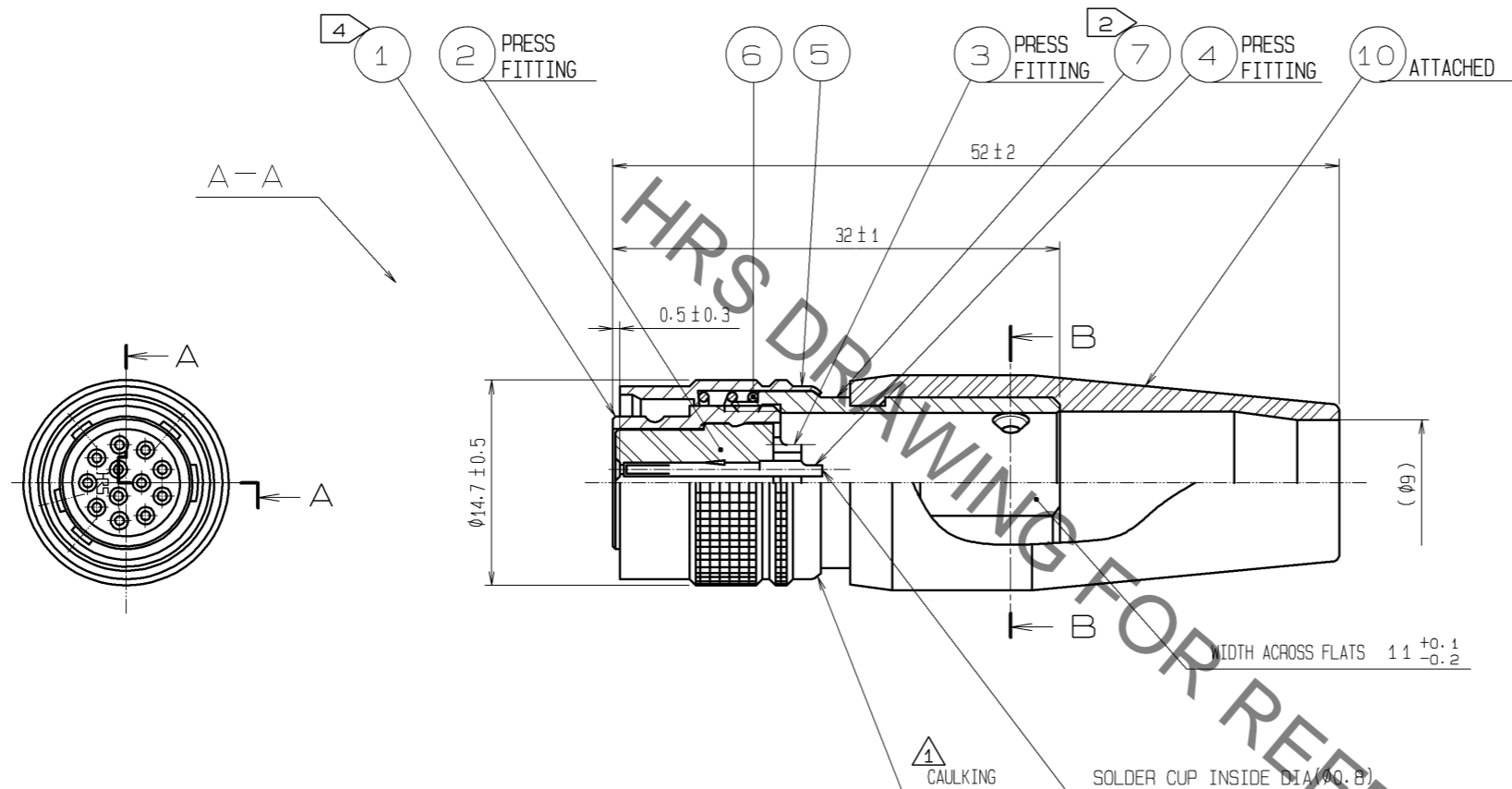

- NOTE
- 1 ONE EXAMPLE OF THE ROTATION OF REF. NO. ⑩ TO REF. NO. ⑩ IS SHOWN.
 - 2 THE RECOMMENDED CLAMP TORQUE, REF. NO. ⑩: 2N·m.
 - 3 ACROSS FLATS HEXAGON HEAD OF REF. NO. ⑩: 1.27
THE RECOMMENDED CLAMP TORQUE, REF. NO. ⑩: 0.3 TO 0.4N·m.
 - 4 LOCTITE 242, HENKEL JAPAN OR EQUIVALENT IS RECOMMENDED TO PREVENT REF. NO. ⑩ AND ⑩ FROM LOOSENING.
 - 5 HAND CRIMPING TOOL, REF. NO. ⑩ : HR10A-TC-03(CL150-0057-2)
 - 6 GOLD PLATING: 0.2µm min.
NICKEL UNDER PLATING: 2µm min.
 - 7 THE CABLE STRENGTH, ROTATORY STRENGTH AND OTHER CHARACTERISTICS MAY DIFFER, DEPENDING ON THE CABLE STRUCTURE. PLEASE CONFIRM BEFORE THE USE.

NO.	MATERIAL	FINISH . REMARKS	NO.	MATERIAL	FINISH . REMARKS
5	BRASS	MATTE FINISH NICKEL PLATING	10	CHLOROPRENE RUBBER	(BLACK)
4	PHOSPHOR BRONZE	⑥	9	BRASS	
3	PHOSPHOR BRONZE	⑥	8	STEEL	NICKEL PLATING JIS B 1177 HEXAGON SOCKET SET SCREW M2.6X0.45X3
2	POLYAMIDE	(BLACK) UL94V-0	7	BRASS	NICKEL PLATING
1	ZINC ALLOY	MATTE FINISH NICKEL PLATING	6	STEEL	NICKEL PLATING

UNITS mm		SCALE 2 : 1	COUNT 1	DESCRIPTION OF REVISIONS DIS-C-001909	DESIGNED WR. AJIRO	CHECKED HY. KISHI	DATE 10.10.16
HRS HIROSE ELECTRIC CO., LTD.		APPROVED : MO. SATOH	06.08.01	DRAWING NO. EDC3-041594-74			
		CHECKED : EJ. KUNII	06.08.01	PART NO. HR10A-10PD-12S(74)			
		DESIGNED : DS. MATSUNE	06.08.01	CODE NO. CL110-0449-3-74			
		DRAWN : MK. SATO	06.07.12				

Mouser Electronics

Authorized Distributor

Click to View Pricing, Inventory, Delivery & Lifecycle Information:

[Hirose Electric:](#)

[HR10A-10PD-12S\(74\)](#)