

Sep.1.2021 Copyright 2021 HIROSE ELECTRIC CO., LTD. All Rights Reserved.
In case of consideration for using Automotive equipment / device which demand high reliability, kindly contact our sales window correspondents.

Recommended land pattern dimension of PCB

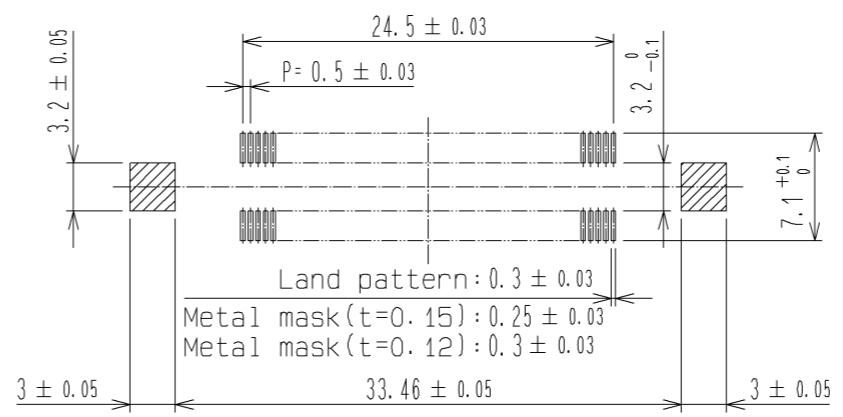

Drawing for mating (No scale)

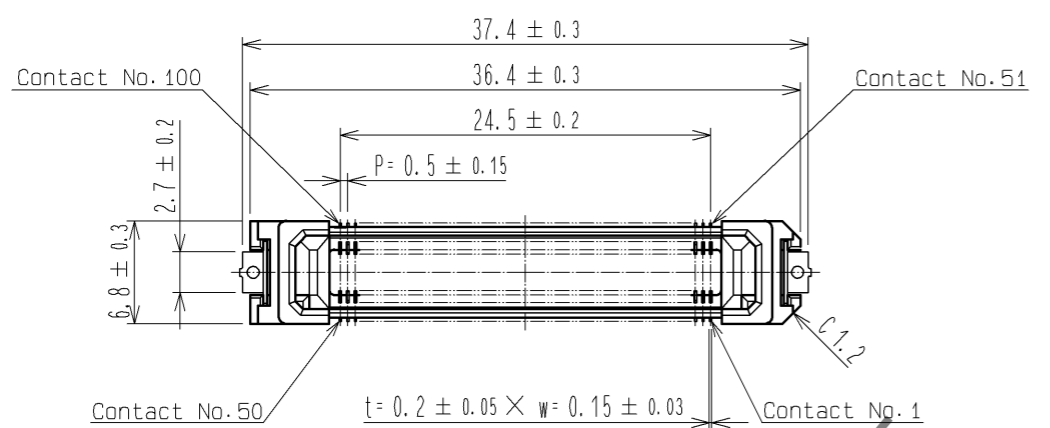
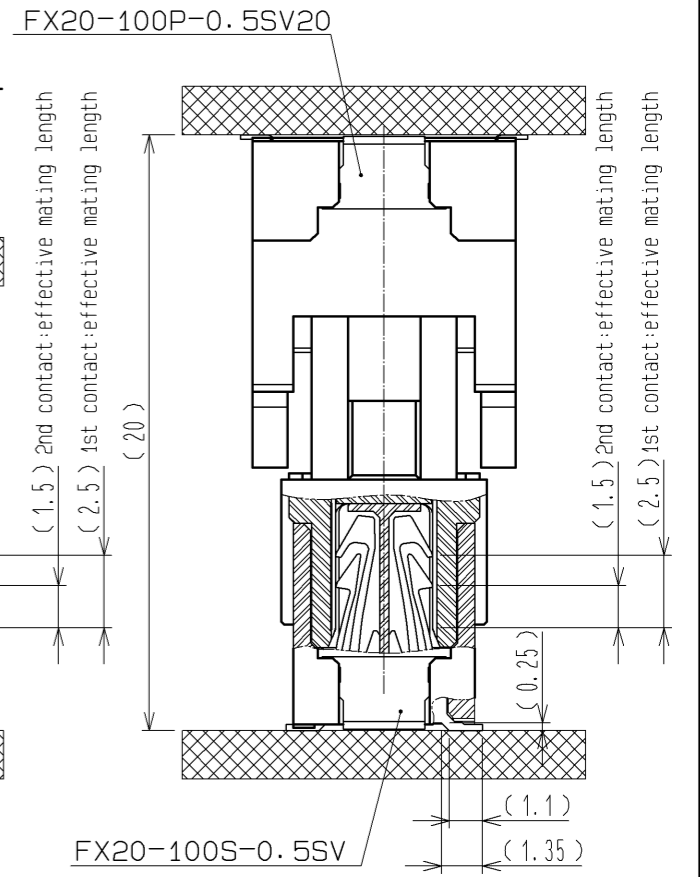

Drawing for mating (No scale)

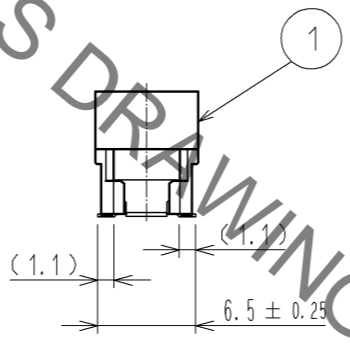
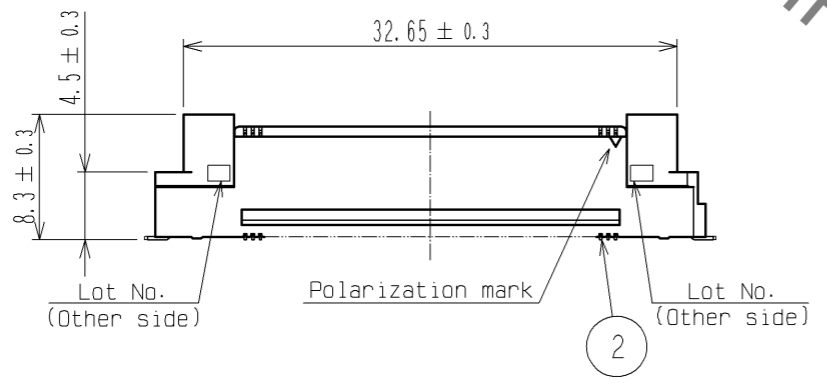
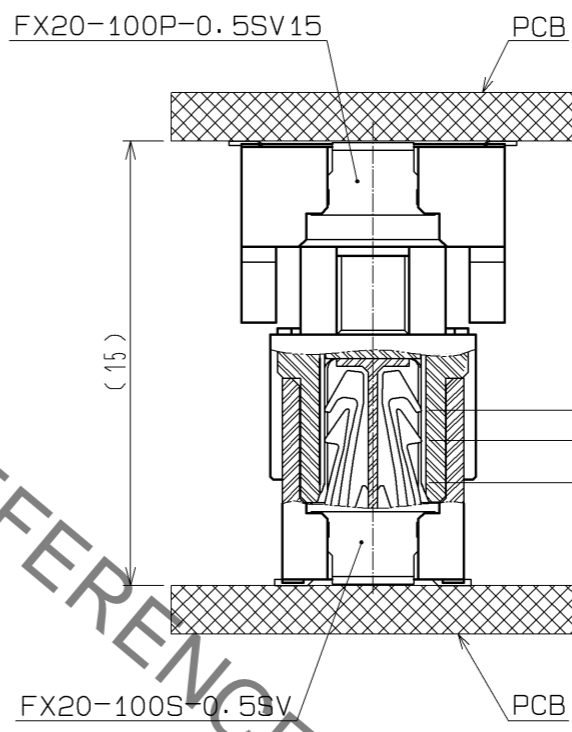

2 Drawing for packing (No scale)

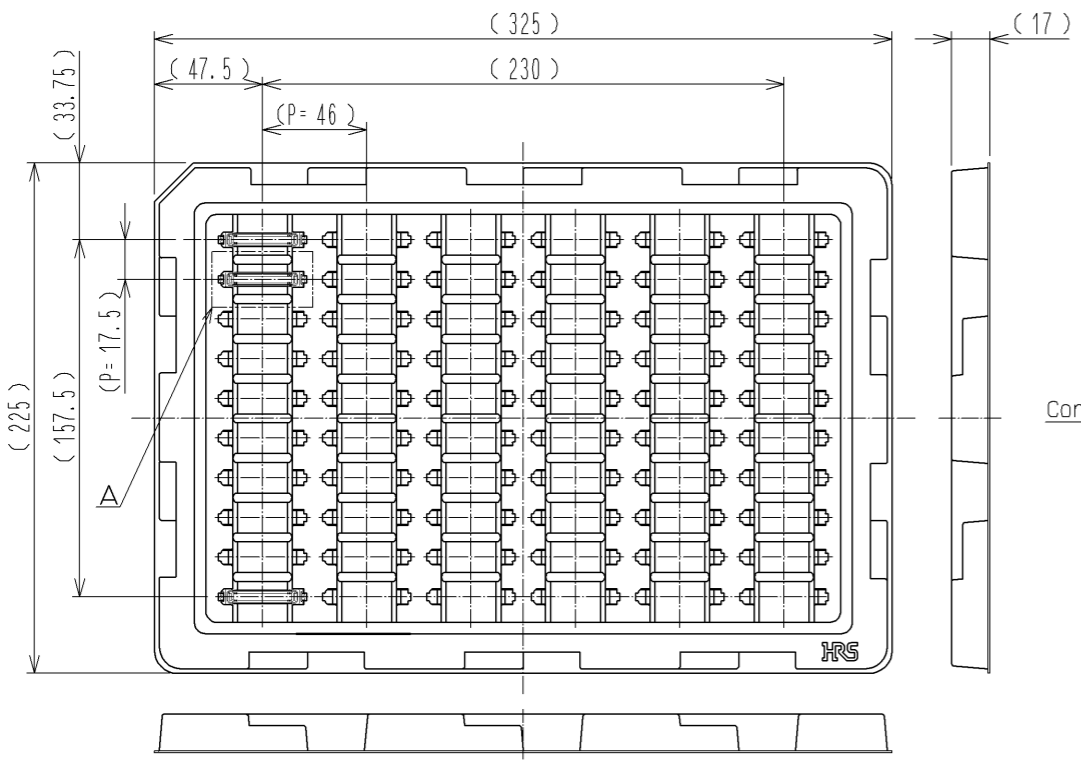

A (1:1)

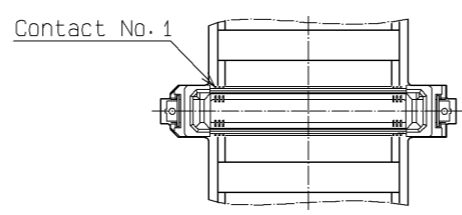

- 1 Lead CO-Planarity is 0.1mm MAX.
- 2 This is packaged in tray. (60pcs/tray)
- 3 Blemish and hit mark can be occurred through out the manufacturing process which doesn't affect quality level.
- 4 Please note that excessive wrenching force could damage this connector. Please refer to the guideline for detailed regulations of the mating method.
- 5 The dimensions in parentheses are for references.

1	LCP	BLACK	UL94V-0	3	BRASS	TIN-PLATING 1 μm		
				2	PHOSPHOR BRONZE	CONTACT AREA: GOLD 0.1 μm LEAD AREA: GOLD 0.03 μm UNDER PLATING: NICKEL 1 μm		
NO.	MATERIAL	FINISH	REMARKS	NO.	MATERIAL	FINISH . REMARKS		
UNITS	mm	SCALE	2 : 1	COUNT	DESCRIPTION OF REVISIONS	DESIGNED	CHECKED	DATE
APPROVED : HS. OKAWA				13.10.07	DRAWING NO. EDC3-336341-00			
CHECKED : KI. HIROKAWA				13.10.07	PART NO. FX20-100S-0.5SV			
DESIGNED : TS. OONO				13.10.07	CODE NO. CL570-1104-3-00			
DRAWN : TS. OONO				13.10.07	1/1			

Mouser Electronics

Authorized Distributor

Click to View Pricing, Inventory, Delivery & Lifecycle Information:

[Hirose Electric:](#)

[FX20-100S-0.5SV](#)