

Sep.1.2021 Copyright 2021 HIROSE ELECTRIC CO., LTD. All Rights Reserved.
In case of consideration for using Automotive equipment / device which demand high reliability, kindly contact our sales window correspondents.

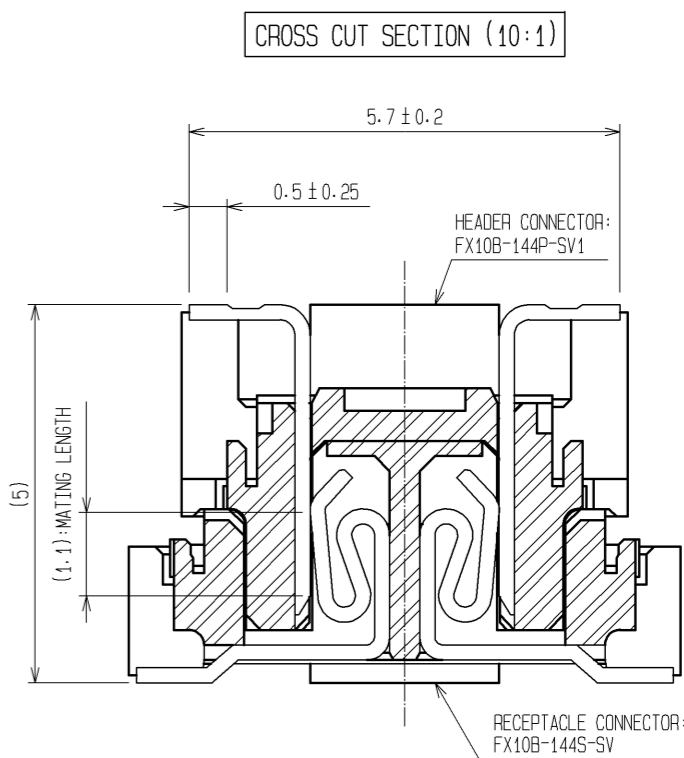

RECOMMENDED LAND PATTERN DIMENSION OF PCB
(RECOMMENDED METAL MASK THICKNESS: 0.15mm)

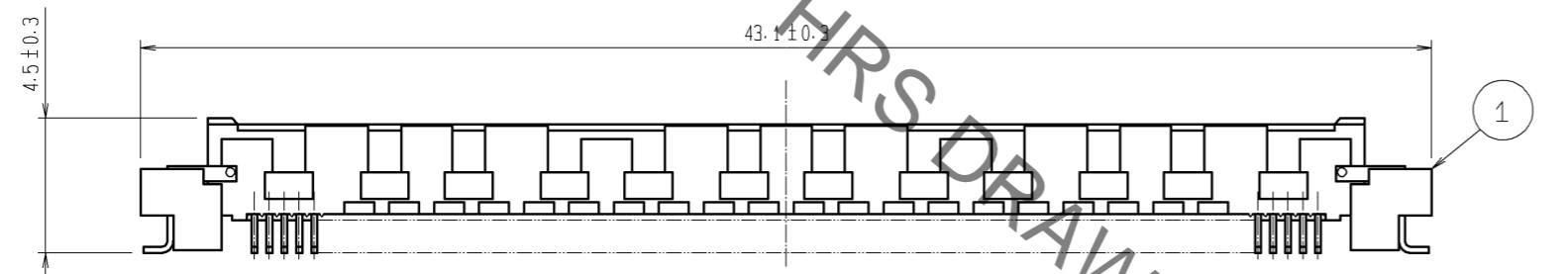
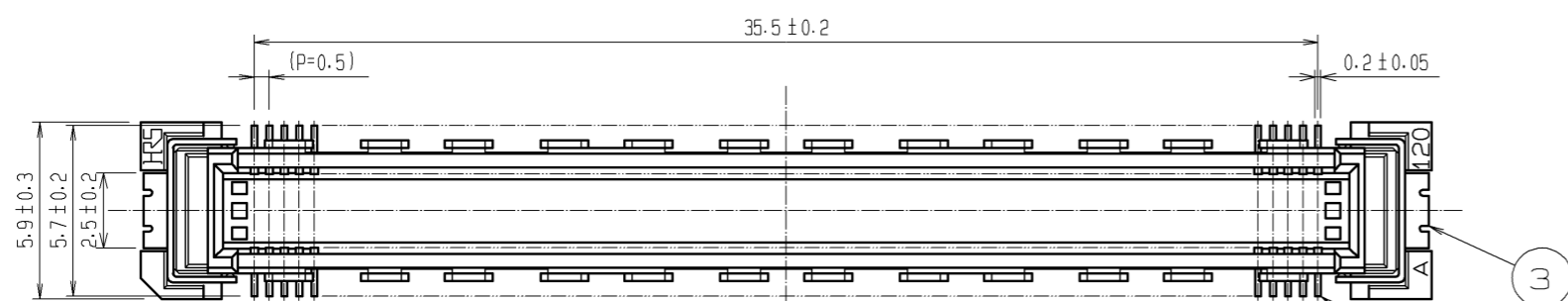
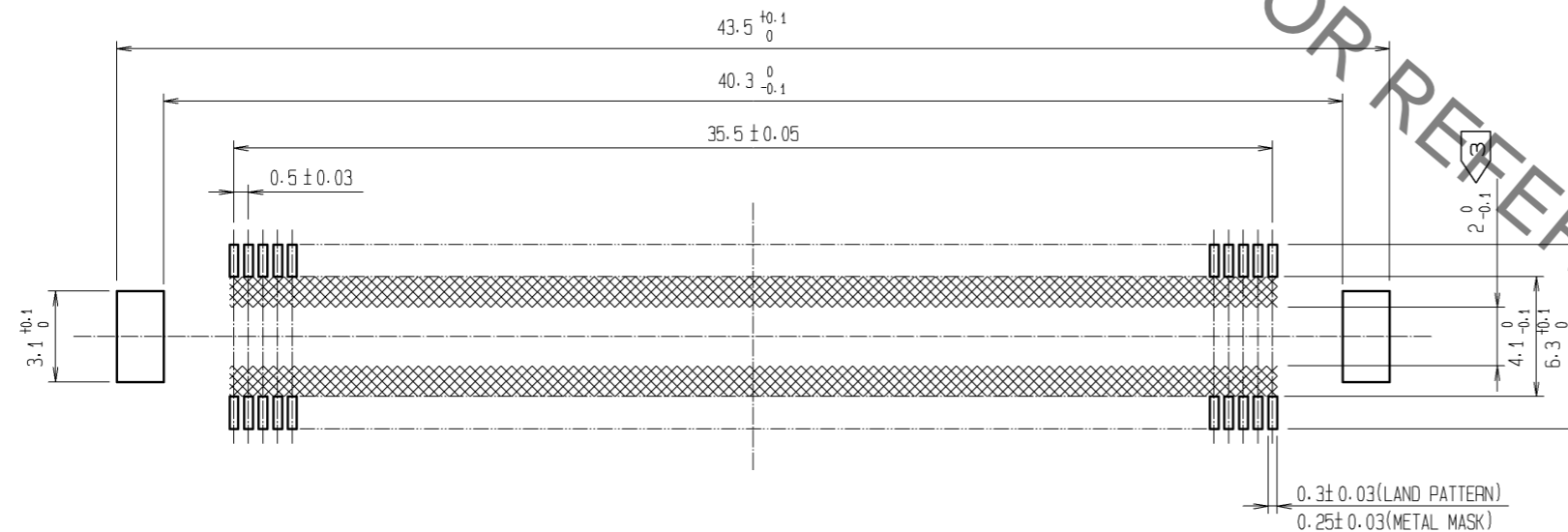

- NOTES
- 1 SMT LEAD-COPLANARITY: 0.1 MAX.
 - 2 THIS PRODUCT HAS NO POLARITY TO PATTERN FOR MOUNTING.
 - ③ MAKE SURE WIDTH OF PATTERN IS WITHIN THAT OF LAND, OR LEAD MAY TOUCH PATTERN. (THIS APPLIES TO HATCHED AREA.)
 - 4 EMBOSS CARRIER TAPE PACKAGE IS APPLIED ON THIS PRODUCT. PLEASE REFER TO THE SHEET 2/2 FOR THE DETAILS.
 - 5 THE DIMENSIONS IN PARENTHESES ARE FOR REFERENCE.

3	PHOSPHOR BRONZE	TIN-PLATING			
2	PHOSPHOR BRONZE	CONTACT AREA: GOLD 0.1μm min. LEAD AREA: TIN-PLATING 1μm min. UNDER PLATING: NICKEL 1μm min.	5	POLYESTER	TOP COVER TAPE
1	LCP	BEIGE UL94V-0	4	POLYSTYRENE	EMBOSSED CARRIER TAPE
NO.	MATERIAL	FINISH, REMARKS	NO.	MATERIAL	FINISH, REMARKS
UNITS: mm		SCALE: 4:1	COUNT: △	DESCRIPTION OF REVISIONS	
DESIGNED		CHECKED		DATE	
APPROVED: HT. YAMAGUCHI			10.07.29	DRAWING NO. EDC3-151974-21	
CHECKED: HT. YAMAGUCHI			10.07.29	PART NO. FX10B-144P-SV1(91)	
DESIGNED: SY. KAMIGA			10.07.29	CODE NO. CL570-0153-3-91	
DRAWN: HK. SUNADORI			10.07.28	△ 1/2	

Sep.1.2021 Copyright 2021 HIROSE ELECTRIC CO., LTD. All Rights Reserved.
 In case of consideration for using Automotive equipment / device which demand high reliability, kindly contact our sales window correspondents.

DRAWING FOR PACKING(2:1)

REELED DIMENSION(Free)

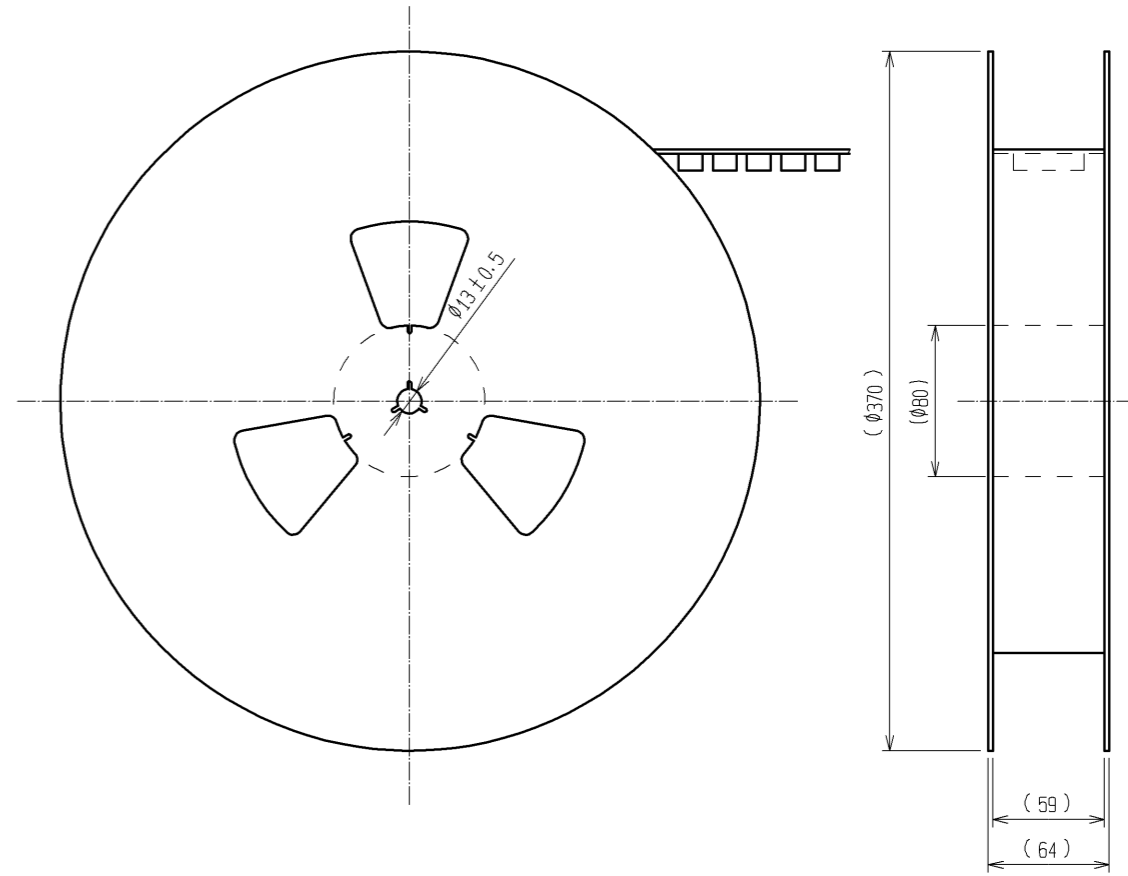
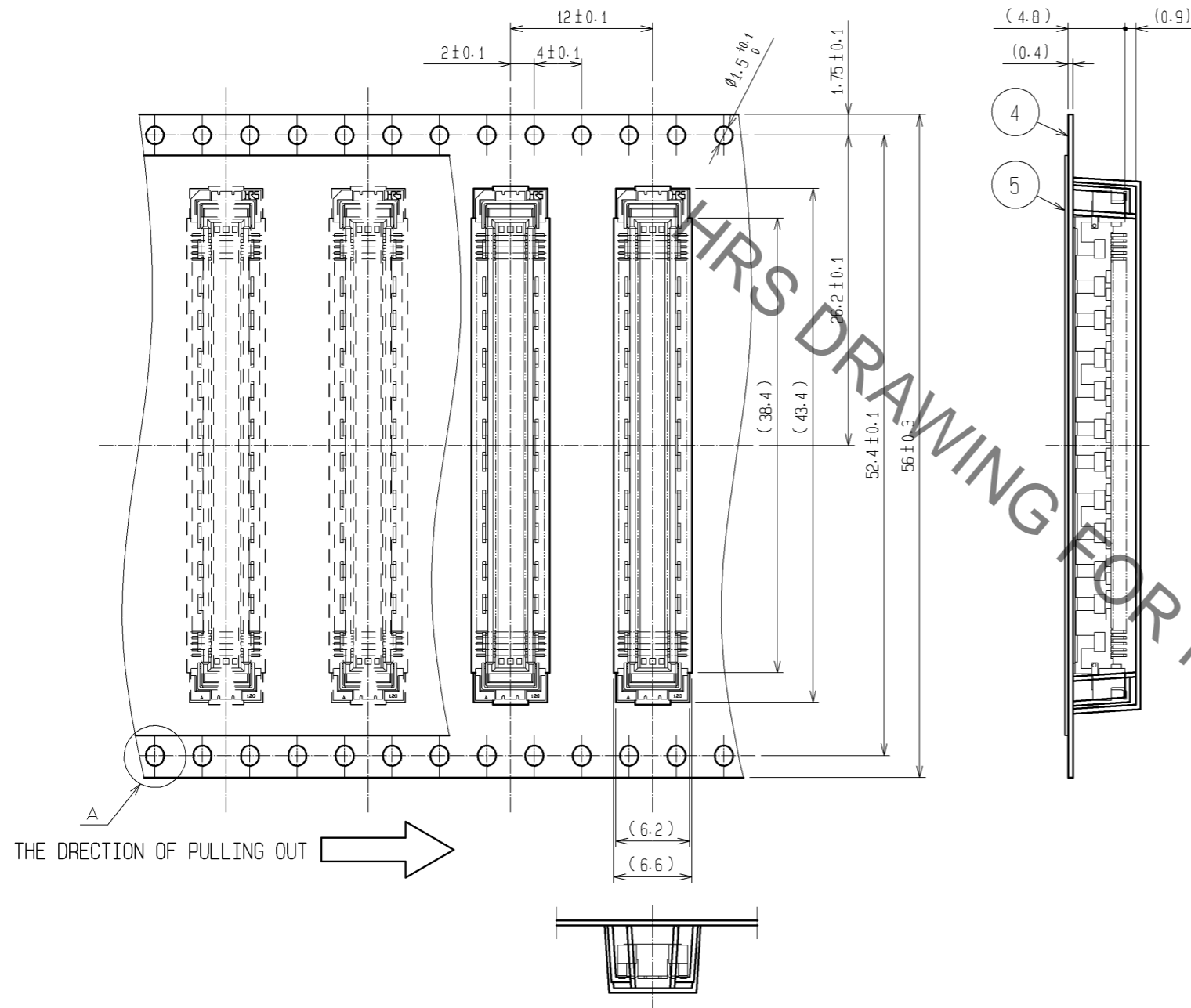

A (5:1)

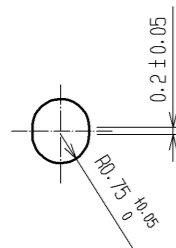

- NOTES
- 1 REEL : 1000 CONNECTORS.
 - 2 MINIMUM 10 COMPARTMENTS FROM BOTH REEL ENDS REMAIN EMPTY.
 - 3 THIS PRODUCT HAS NO POLARITY TO TAPE AND REEL PACKAGING.
 - 4 THE DIMENSIONS IN PARENTHESES ARE FOR REFERENCE.

HRS	DRAWING NO.	EDC3-151974-21
	PART NO.	FX10B-144P-SV1(91)
	CODE NO.	CL570-0153-3-91
		△ 2/2

Mouser Electronics

Authorized Distributor

Click to View Pricing, Inventory, Delivery & Lifecycle Information:

[Hirose Electric:](#)

[FX10B-144P-SV1\(91\)](#)