

Sep.1.2021 Copyright 2021 HIROSE ELECTRIC CO., LTD. All Rights Reserved.
In case of consideration for using Automotive equipment / device which demand high reliability, kindly contact our sales window correspondents.

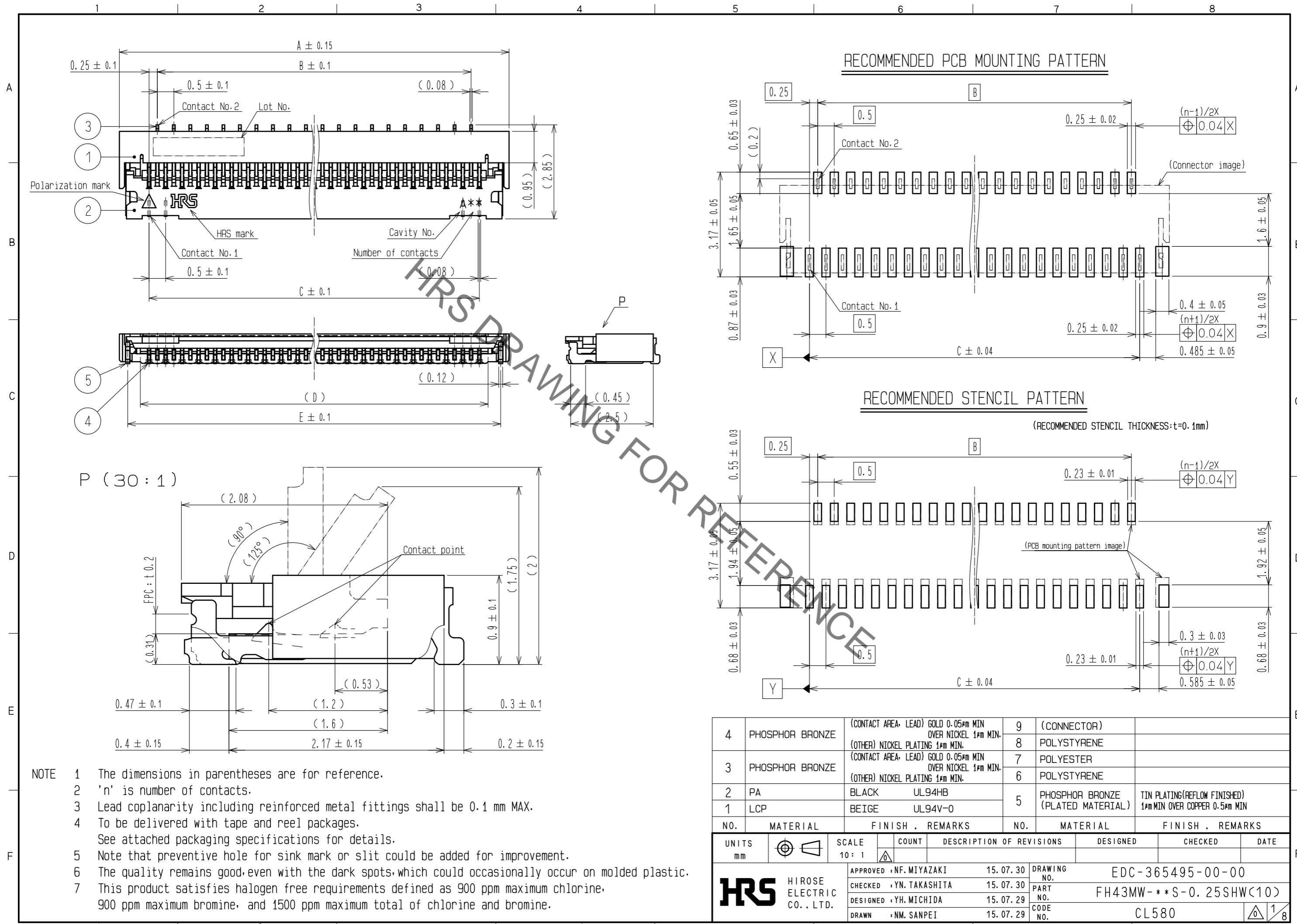

4	PHOSPHOR BRONZE	(CONTACT AREA, LEAD) GOLD 0.05μm MIN OVER NICKEL 1μm MIN. (OTHER) NICKEL PLATING 1μm MIN.	9	(CONNECTOR)	
3	PHOSPHOR BRONZE	(CONTACT AREA, LEAD) GOLD 0.05μm MIN OVER NICKEL 1μm MIN. (OTHER) NICKEL PLATING 1μm MIN.	8	POLYSTYRENE	
2	PA	BLACK UL94HB	7	POLYESTER	
1	LCP	BEIGE UL94V-0	6	POLYSTYRENE	
			5	PHOSPHOR BRONZE (PLATED MATERIAL)	TIN PLATING (REFLOW FINISHED) 1μm MIN OVER COPPER 0.5μm MIN
NO.	MATERIAL	FINISH . REMARKS	NO.	MATERIAL	FINISH . REMARKS
UNITS mm		SCALE 10 : 1	COUNT	DESCRIPTION OF REVISIONS	
DESIGNED		CHECKED		DATE	
APPROVED : NF. MIYAZAKI 15. 07. 30			DRAWING NO. EDC-365495-00-00		
CHECKED : YN. TAKASHITA 15. 07. 30			PART NO. FH43MW-**S-0.25SHW<10>		
DESIGNED : YH. MICHIDA 15. 07. 29			CODE NO. CL580		
DRAWN : NM. SANPEI 15. 07. 29			1/8		

Sep.1.2021 Copyright 2021 HIROSE ELECTRIC CO., LTD. All Rights Reserved.
In case of consideration for using Automotive equipment / device which demand high reliability, kindly contact our sales window correspondents.

RECOMMENDED FPC (20:1)

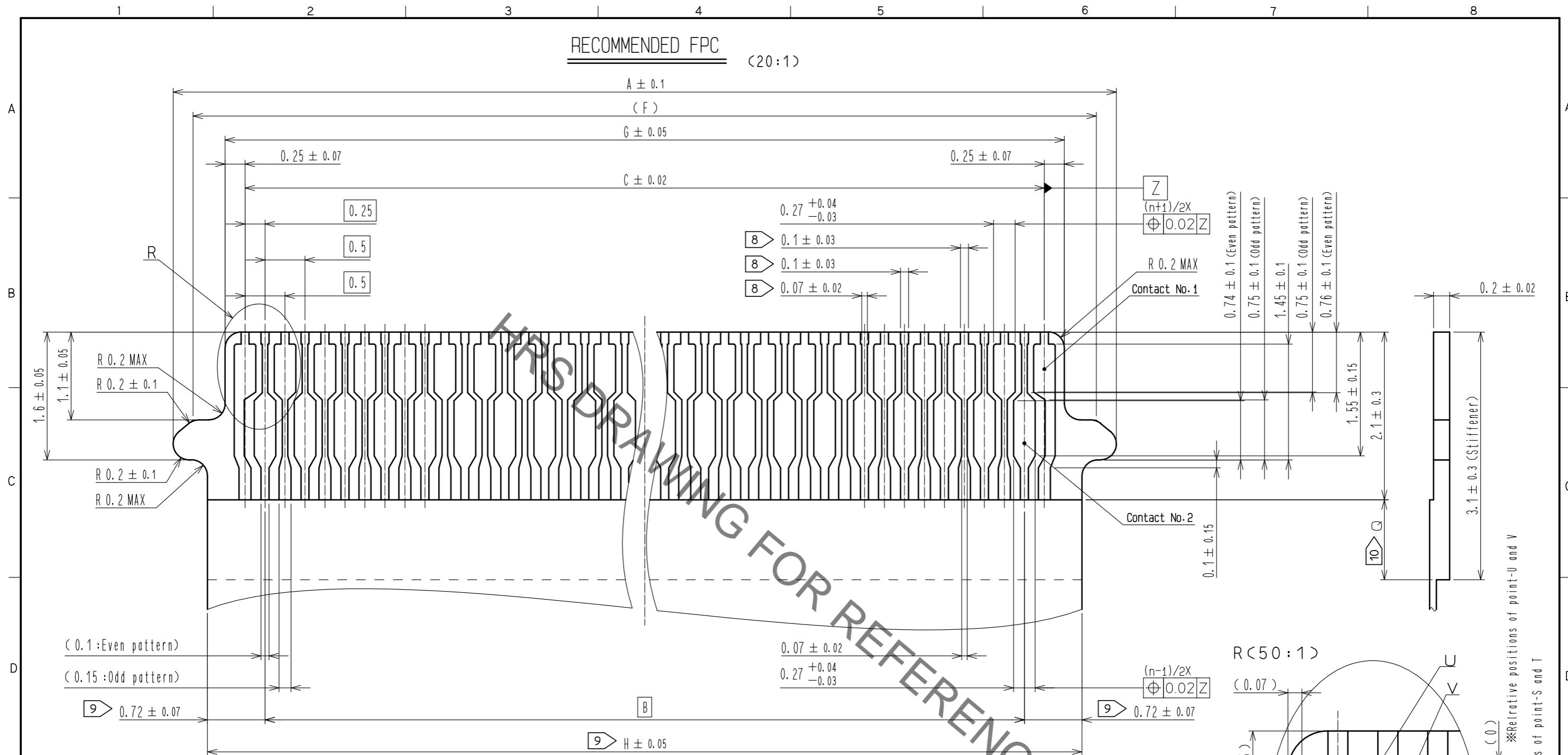

NOTE 8 Shows recommended dimension when lead for plating is required.
9 Indicated tolerance is applicable to the exposed conductor.
10 Dimension Q must be 0.5mm minimum.

FPC CONFIGURATION (REFERENCE EXAMPLE) (FREE)

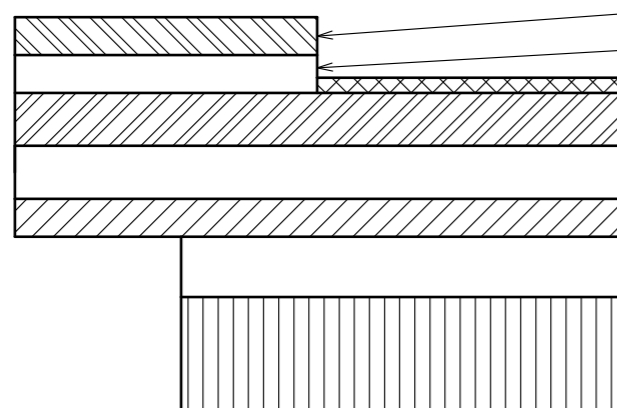

MATERIAL NAME	MATERIAL	THICKNESS(μm)
COVERING FILM LAYER	POLYIMIDE 1 mil	25
COVER ADHESIVE		25
SURFACE TREATMENT	1μm TO 6μm NICKEL UNDERPLATED 0.2μm GOLD PLATED.	(4)
COPPER FOIL	Cu 1 oz	35
BASE ADHESIVE	HEAT-HARDENED ADHESIVE	25
BASE FILM	POLYIMIDE 1 mil	25
REINFORCEMENT MATERIAL ADHESIVE	HEAT-HARDENED ADHESIVE	40
STIFFENER	POLYIMIDE 3 mil	75

R<50:1>

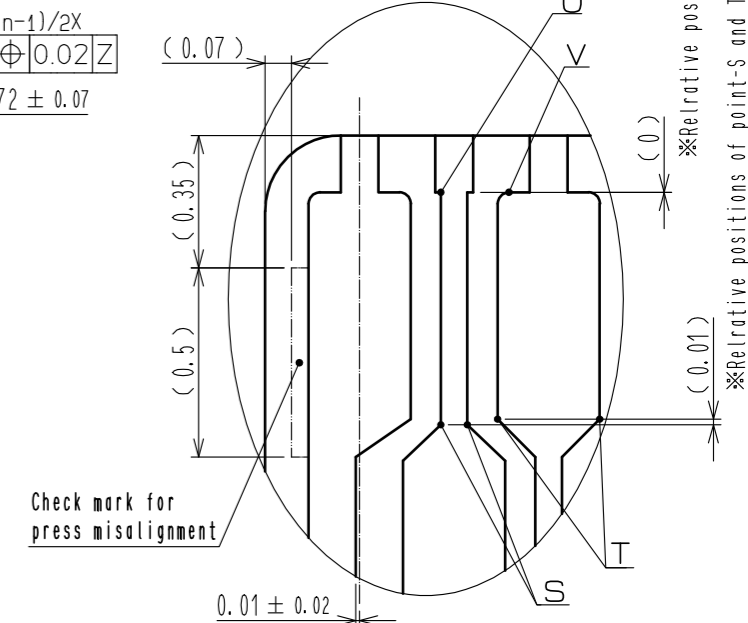

<RECOMMENDED FPC>

HRS	DRAWING NO.	EDC-365495-00-00
	PART NO.	FH43MW-***S-0.25SHW<10>
	CODE NO.	CL580
		2/8

Sep.1.2021 Copyright 2021 HIROSE ELECTRIC CO., LTD. All Rights Reserved.
 In case of consideration for using Automotive equipment / device which demand high reliability, kindly contact our sales window correspondents.

EMBOSSED CARRIER TAPE DIMENSION (2:1)

◎24mm MAX.

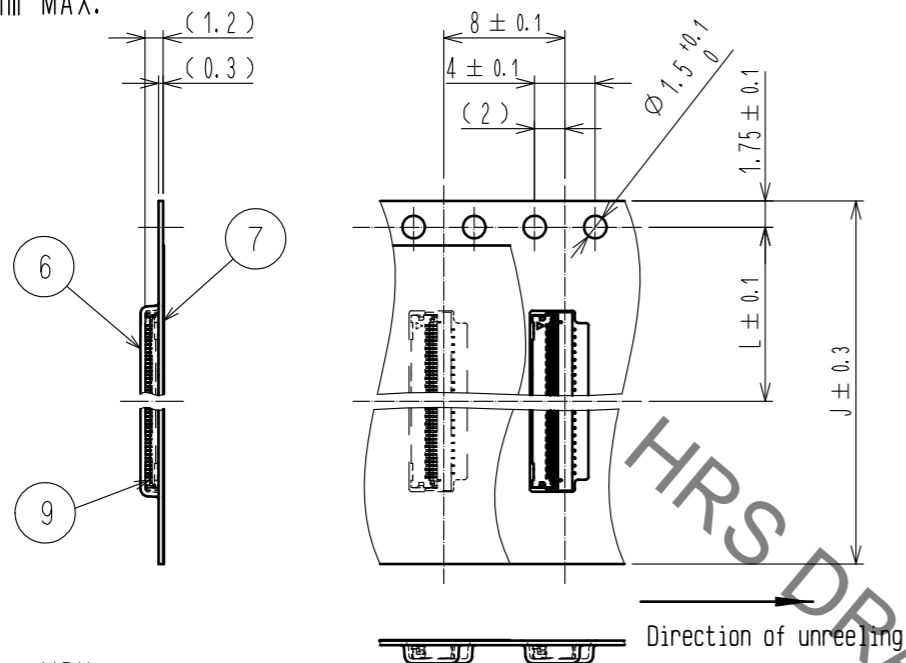

◎32mm MIN.

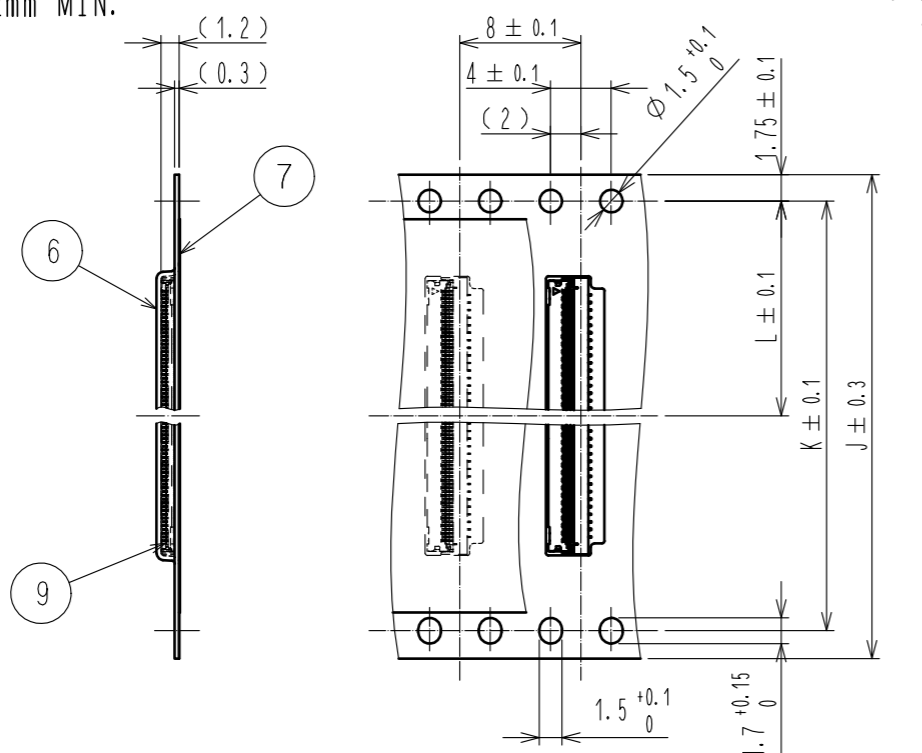

REEL DIMENSION (FREE)

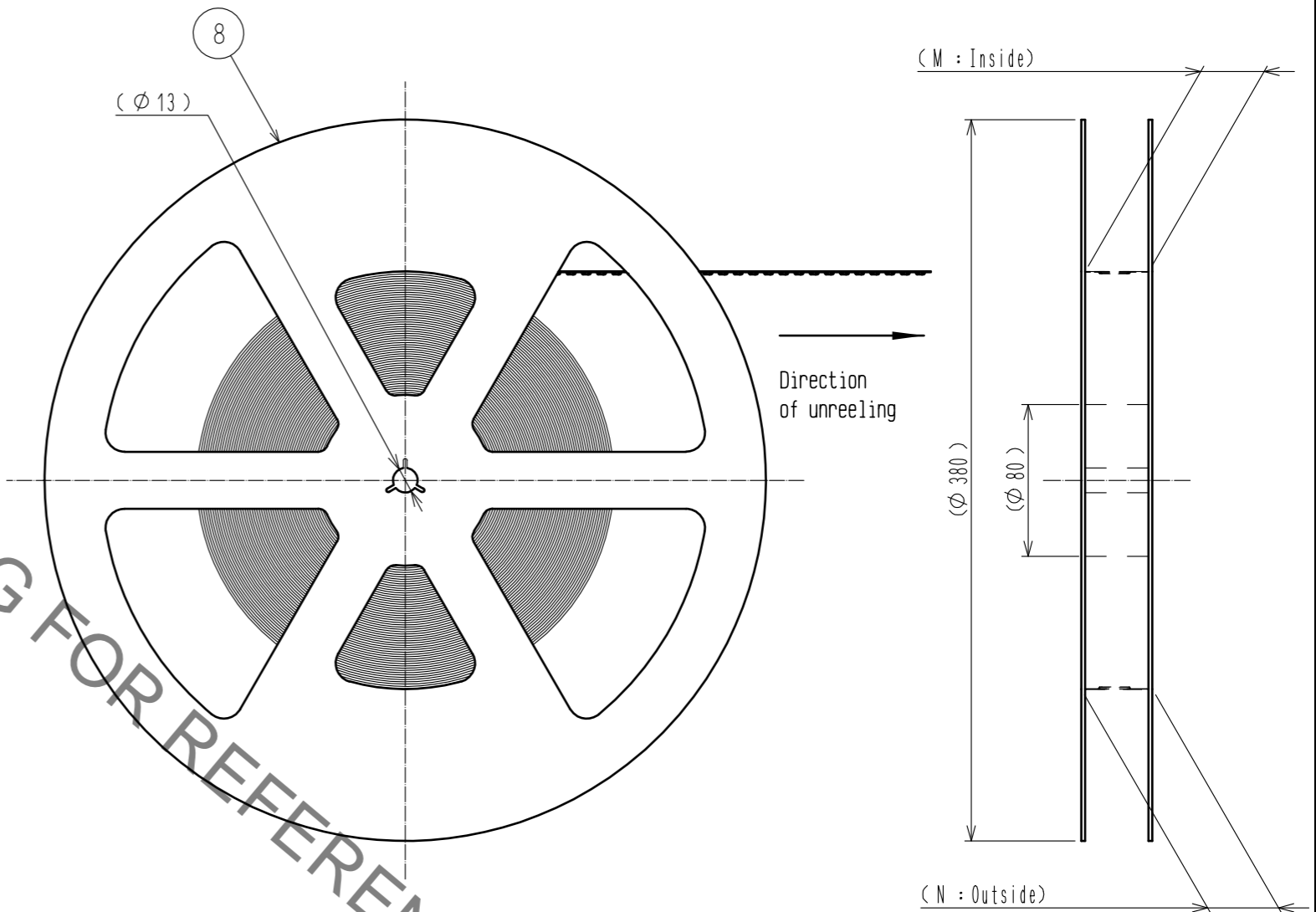

LEADER, TRAILER DIMENSION (FREE)

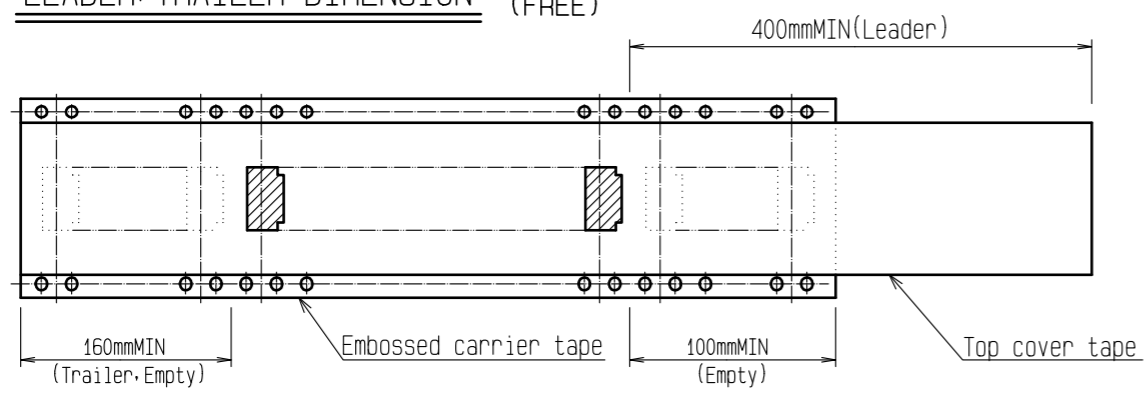

NOTE 11 Per reel : 5000 connectors.
 12 Refer to JIS C 0806 and IEC 60286-3
 (Packaging of components for automatic handling.)

<DRAWING FOR PACKING>

HRS	DRAWING NO.	EDC-365495-00-00
	PART NO.	FH43MW-**S-0.25SHW<10>
	CODE NO.	CL580
		3/8

Sep.1.2021 Copyright 2021 HIROSE ELECTRIC CO., LTD. All Rights Reserved.
In case of consideration for using Automotive equipment / device which demand high reliability, kindly contact our sales window correspondents.

PART NUMBER	CODE NUMBER	NUMBER OF CONTACTS	DIMENSION OF CONNECTOR, FPC, LAND PATTERN								DIMENSION OF DRAWING FOR PACKING				
			A	B	C	D	E	F	G	H	J	K	L	M	N
FH43MW-17S-0.25SHW(10)	-	17	5.8	3.5	4	4.53	5.29	5.3	4.5	4.94	16	-	7.5	17.4	21.4
FH43MW-19S-0.25SHW(10)	CL580-2823-2-10	19	6.3	4	4.5	5.03	5.79	5.8	5	5.44	16	-	7.5	17.4	21.4
FH43MW-25S-0.25SHW(10)		25	7.8	5.5	6	6.53	7.29	7.3	6.5	6.94	24	-	11.5	25.4	29.4
FH43MW-31S-0.25SHW(10)	-	31	9.3	7	7.5	8.03	8.79	8.8	8	8.44	24	-	11.5	25.4	29.4
FH43MW-35S-0.25SHW(10)	-	35	10.3	8	8.5	9.03	9.79	9.8	9	9.44	24	-	11.5	25.4	29.4
FH43MW-39S-0.25SHW(10)	-	39	11.3	9	9.5	10.03	10.79	10.8	10	10.44	24	-	11.5	25.4	29.4
FH43MW-41S-0.25SHW(10)	CL580-2824-5-10	41	11.8	9.5	10	10.53	11.29	11.3	10.5	10.94	24	-	11.5	25.4	29.4
FH43MW-55S-0.25SHW(10)	CL580-2818-2-10	55	15.3	13	13.5	14.03	14.79	14.8	14	14.44	24	-	11.5	25.4	29.4

* CONTACT POSITIONS WITHOUT CODE NUMBERS ARE CURRENTLY UNDER PLANNING.
CONTACT HIROSE FOR DETAILED INFORMATION ABOUT PRODUCT VARIATION.

HRS	DRAWING NO.	EDC-365495-00-00
	PART NO.	FH43MW-**S-0.25SHW(10)
	CODE NO.	CL580

4/8

Sep.1.2021 Copyright 2021 HIROSE ELECTRIC CO., LTD. All Rights Reserved.
In case of consideration for using Automotive equipment / device which demand high reliability, kindly contact our sales window correspondents.

This connector features small and thin, requiring delicate and careful handling. To prevent connector/FPC breakage and contact failure (mating failure, FPC pattern breakage, etc), read through the instructions shown below and handle the connector properly. Each values indicating here are for reference and may differ from standard value.

[Operation and Precautions]

1. Initial condition

The connector is delivered with the actuator closed.

[Caution]

-Do not insert FPC or operate actuator before mounting.

2. How to unlock (Before inserting FPC)

Slowly flip up the actuator to release the lock.

[Caution]

- The actuator rotates on its axis as shown below.
- Make sure to operate the actuator with a rotating motion.
- When operating the actuator do not apply any force in the direction of the connector.
- Open the actuator by carefully lifting it at the center.
- Do not lift it at one end only.
- The actuator must be operated by hand only, and do not insert any tools or fingernails inside the connector.
- The actuator rotates 125 degrees max.
- Do not attempt to force the actuator to backside further.
- Do not attempt to dislodge the open actuator.

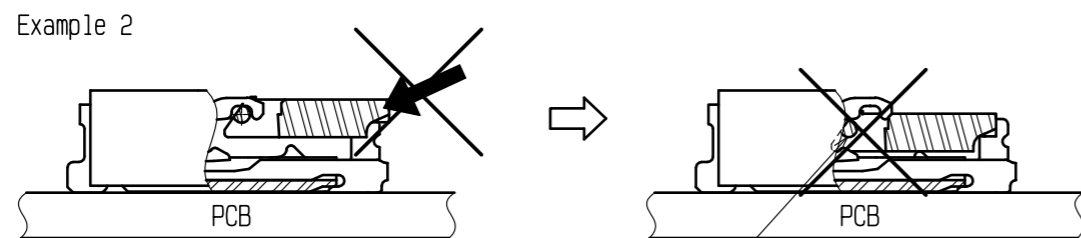
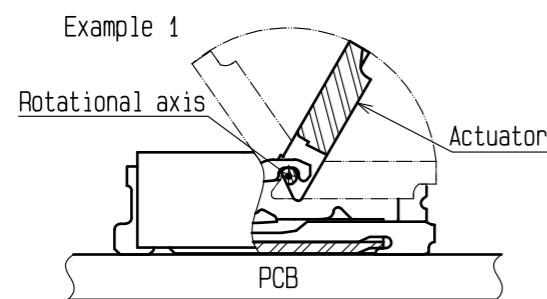

failure from the actuator pushed in

- Incorrect operation -

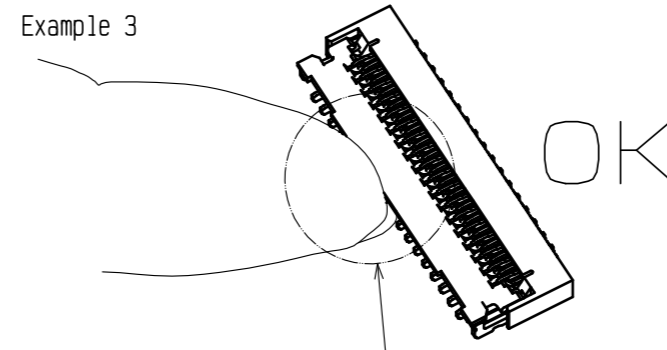

Open the actuator at the center

- Correct operation -

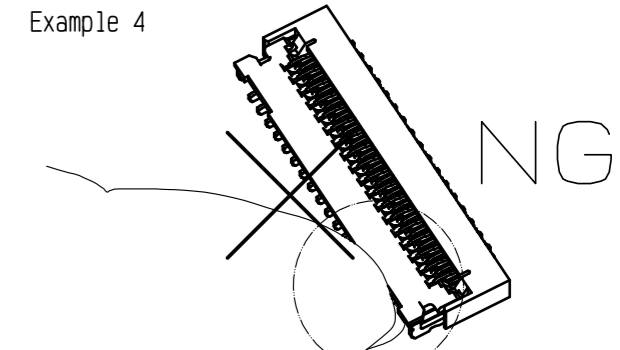

Do not operate the actuator at one end only.

- Incorrect operation -

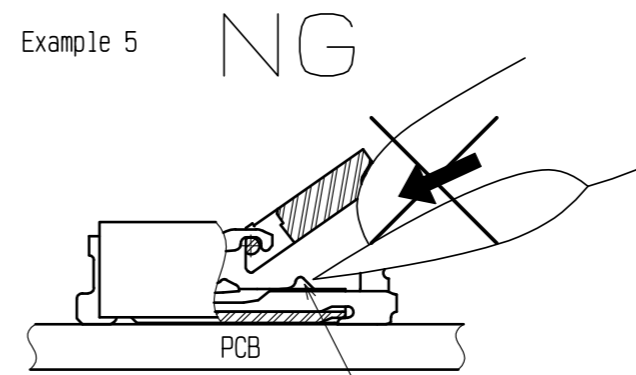

Deformation of the terminal

- Incorrect operation -

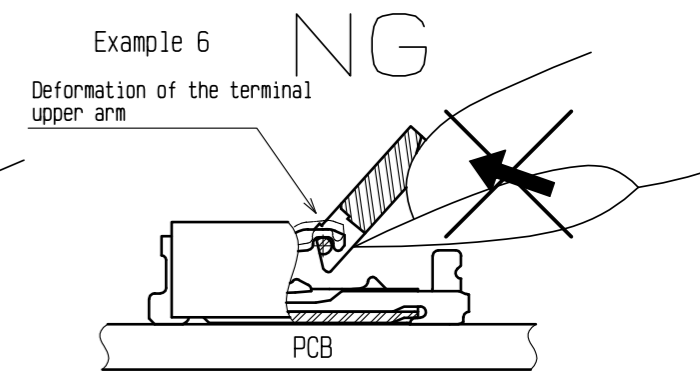

Deformation of the terminal upper arm

- Incorrect operation -

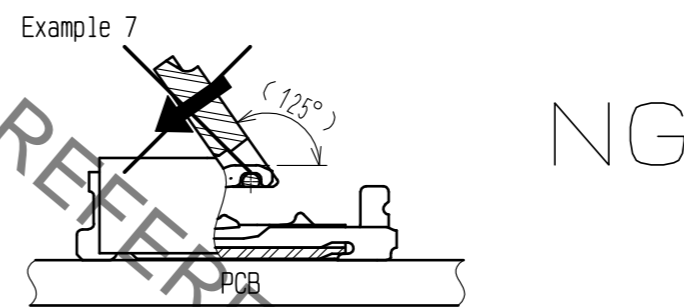

Example 7

- Incorrect operation -

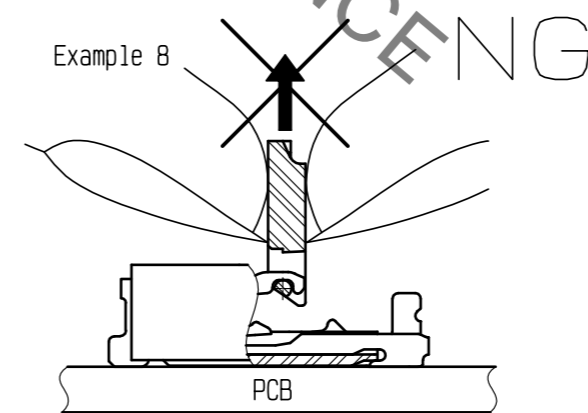

Example 8

- Incorrect operation -

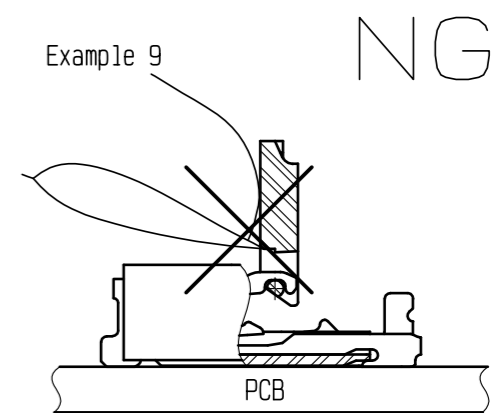

Example 9

- Incorrect operation -

<INSTRUCTION MANUAL(1)>

HRS	DRAWING NO.	EDC-365495-00-00
	PART NO.	FH43MW-**S-0.25SHW<10>
	CODE NO.	CL580
		5/8

Sep.1.2021 Copyright 2021 HIROSE ELECTRIC CO., LTD. All Rights Reserved.
In case of consideration for using Automotive equipment / device which demand high reliability, kindly contact our sales window correspondents.

3. How to insert FPC

This connector has contacts on the bottom. Insert the FPC with the exposed conductors face down.

[Caution]

- Insert the FPC with the actuator opened.
- Do not insert the FPC with the conductor surface face up.
- Insert the FPC at about 15 degree angle to the PCB mounting surface.
- Insert it properly to the very end.
- Do not insert the FPC at an angle.
- Do not twist the FPC to up and down, right and left or an angle.

Example 10

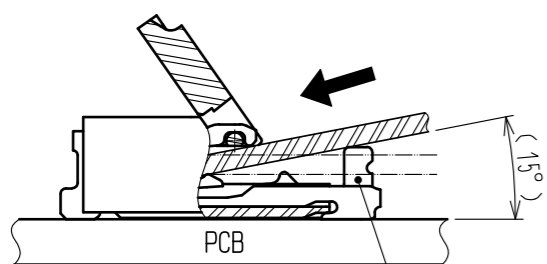

Metal fitting for positioning FPC

- Correct operation -

OK

Example 11

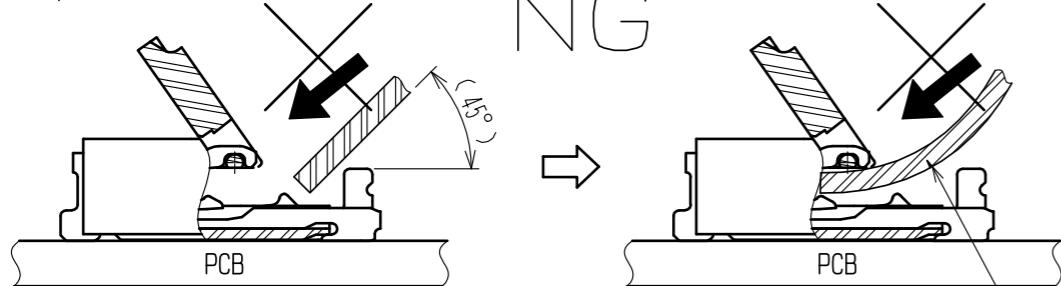

- Incorrect operation -

Pattern breakage

NG

4. FPC insertion check

Metal fittings guide the FPC tabs to the correct position. Make sure that the FPC tabs are located in correct position as shown in the figure below after FPC insertion.

[Caution]

- Do not insert the FPC at an angle and/or stop it before insertion is completed.

Example 12

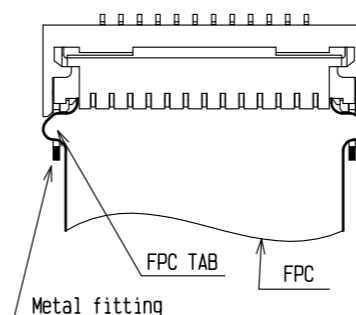

- Correct operation -

Example 13

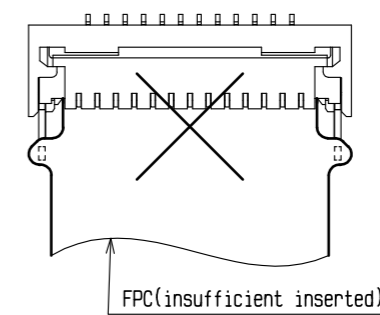

- Incorrect operation -

Example 14

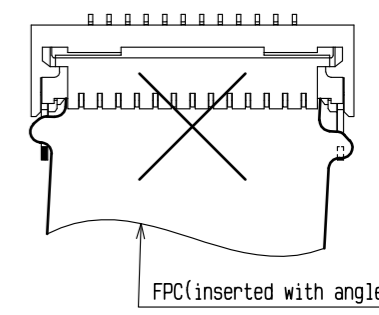

- Incorrect operation -

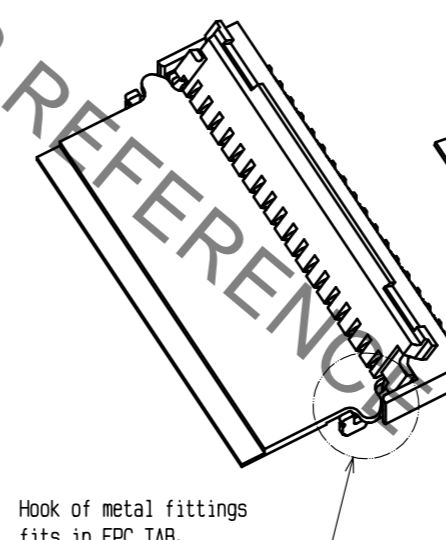

OK

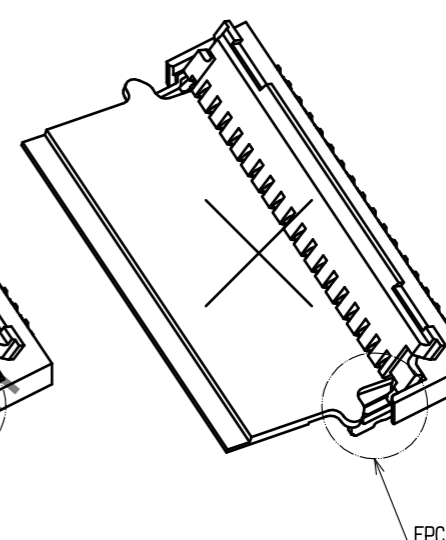

NG

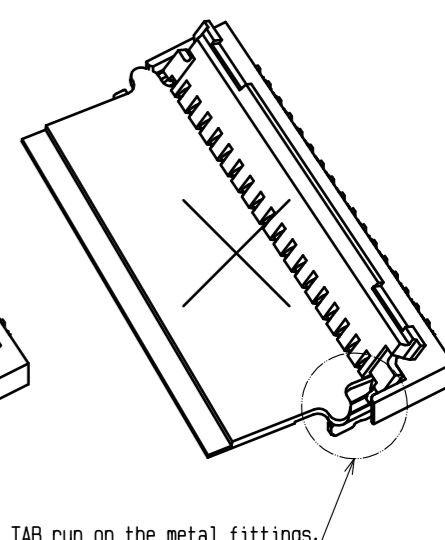

NG

<INSTRUCTION MANUAL(2)>

HRS

DRAWING NO.	EDC-365495-00-00
PART NO.	FH43MW-**S-0.25SHW<10>
CODE NO.	CL580

Sep.1.2021 Copyright 2021 HIROSE ELECTRIC CO., LTD. All Rights Reserved.
In case of consideration for using Automotive equipment / device which demand high reliability, kindly contact our sales window correspondents.

5. How to lock

Apply load to rotate the actuator after inserting the FPC.

[Caution]

- The actuator rotates on its axis.
- Make sure to operate the actuator with a rotating motion.
- Open the actuator by carefully lifting it at the center.
- Do not lift it at one end only.
- The actuator must be operated by hand only, and do not insert any tools or fingernails inside the connector.
- Do not attempt to force the actuator to backside further.
- Do not attempt to dislodge the open actuator.
- Confirm that the actuator completely closed and is parallel to the PCB mounting surface.

Example 15

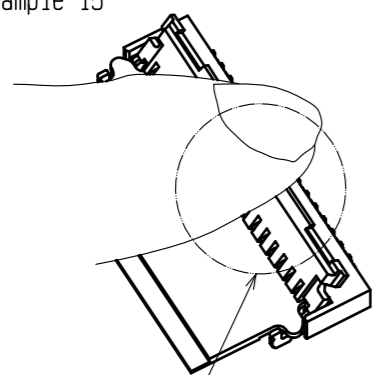

Close the actuator at the center

- Correct operation -

Example 16

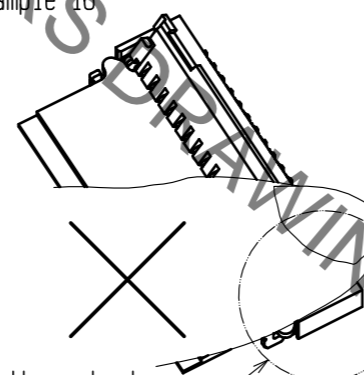

Do not operate the actuator at one end only

- Incorrect operation -

7. How to unlock

Slowly flip up the actuator to release the lock.

[Caution]

- Open the actuator by carefully lifting it at the center.
- Do not lift it at one end only.
- When operating the actuator do not apply any force in the direction of the connector.
- The actuator must be operated by hand only, and do not insert any tools or fingernails inside the connector.
- The actuator rotates 125 degrees max. Do not attempt to force the actuator to backside further.
- Do not attempt to dislodge the open actuator.

Example 20

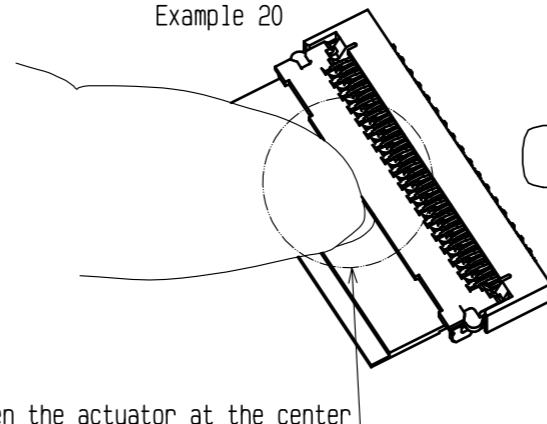

Open the actuator at the center

- Correct operation -

Example 21

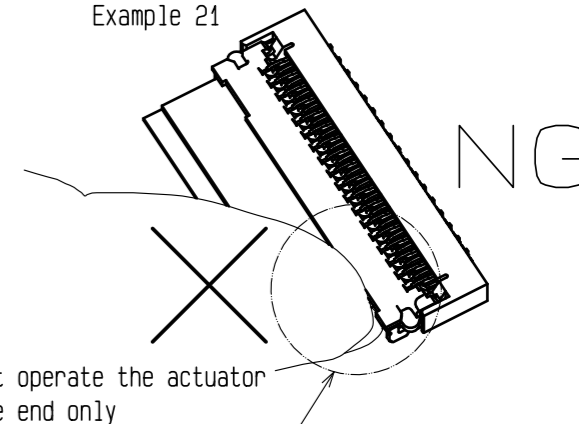

Do not operate the actuator at one end only

- Incorrect operation -

6. Mating confirmation of the FPC

Visually confirm the FPC positioning after closing the actuator.

[Caution]

- Do not insert the FPC at an angle and/or stop it before insertion is completed.

Example 17

FPC fully fills window when FPC is correctly inserted.

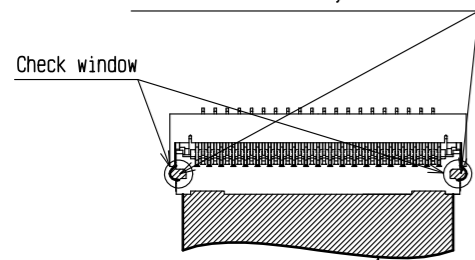

- Correct operation -

Example 18

Window is not fully covered by FPC when FPC is miss-inserted, and FPC tabs extend from the connector.

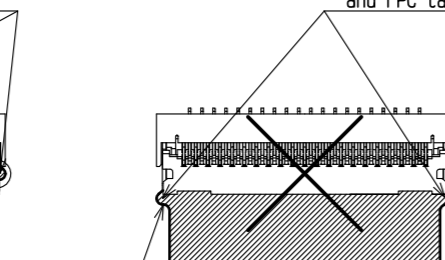

- Incorrect operation -

Example 19

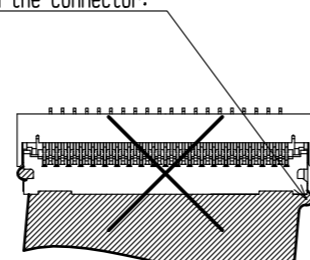

FPC(inserted with angle)

- Incorrect operation -

8. How to remove FPC

After rotating the actuator to the fully opened position carefully withdraw the FPC pulling out at about 15 degree angle to the PCB mounting surface.

[Caution]

- This connector has a temporary FPC holding structure with metal fittings.
- For FPC removal, do not pull out the FPC horizontally.
- Do not attempt to pull the FPC without unlocking the actuator.

Example 22

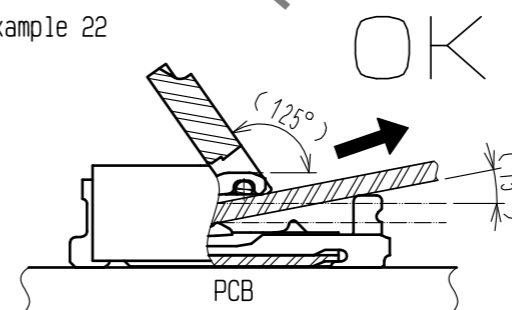

- Correct operation -

Example 23

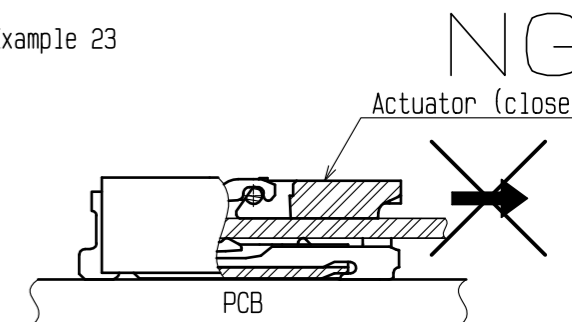

- Incorrect operation -

<INSTRUCTION MANUAL(3)>

HRS	DRAWING NO.	EDC-365495-00-00
	PART NO.	FH43MW-**S-0.25SHW(10)
	CODE NO.	CL580
		7/8

Sep.1.2021 Copyright 2021 HIROSE ELECTRIC CO., LTD. All Rights Reserved.
In case of consideration for using Automotive equipment / device which demand high reliability, kindly contact our sales window correspondents.

[Precautions for design]

1. During FPC wiring, ensure that stress is not applied directly to the connector. Do not bend the FPC excessively near the connector during use, or it may cause contact failure or FPC breakage. Stabilizing the FPC is recommended.
2. Keep a sufficient FPC insertion space in the stage of the layout in order to avoid incorrect FPC insertion. Appropriate FPC length and component layout are recommended for assembly ease. Too short FPC length makes assembly difficult.
3. Follow the recommended PCB mounting pattern, stencil opening design and the FPC design.
4. Make adjustments with the FPC manufacturer for FPC bending performance and wire breakage.
5. Keep spaces for the actuator movement and its operation for PCB design and component layout.

[FPC routing after connection]

Depending on a FPC rounding, a load is applied to the connector, and a contact failure may occur. To prevent a failure, take the following notes into a consideration during mechanism design.

[Caution]

- Avoid applying forces to FPC in vertical or horizontal directions. In addition, avoid pulling up and down on the FPC.
- When fixing FPC after FPC cabling, avoid pulling FPC, and route the wire FPC with slack. In this regard, the stiffener is parallel to the PCB.
- Do not mount other components touching to the FPC underneath the FPC stiffener.

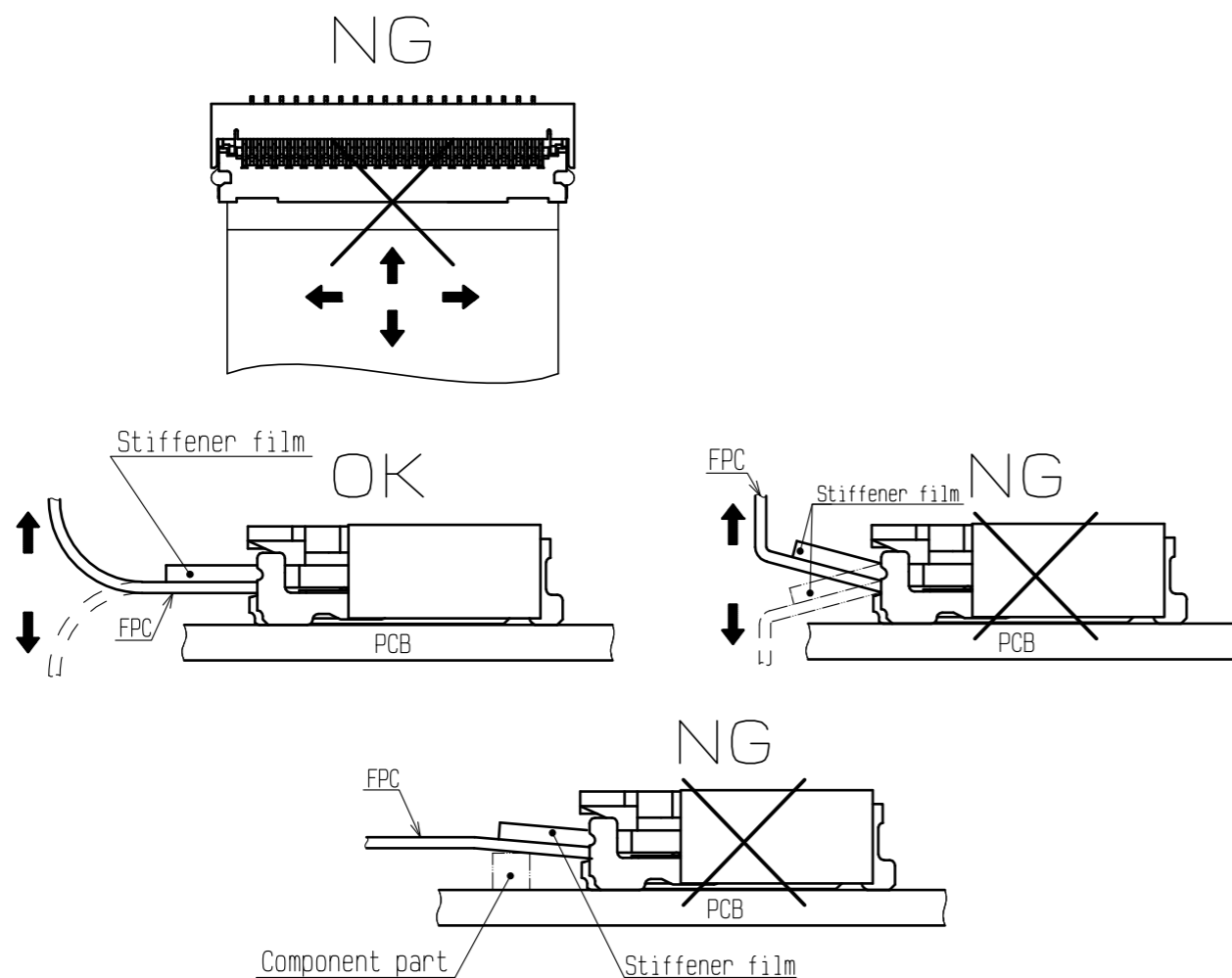

[Instructions for mounting on the PCB]

- ◆Warp of PCB
Minimize warp of the PCB as much as possible. Lead co-planarity including reinforced metal fittings is 0.1 mm or less. Too much warp of the PCB may result in a soldering failure.
- ◆Flexible board design
Please make sure to put a stiffener on the backside of the flexible board. We recommend a glass epoxy material with the thickness of 0.3mm MIN.
- ◆Load to Connector
Do not add 0.5N or greater external force when unreel or pick and place the connector etc, or it may get broken. In addition, do not insert the FPC or operate the connector before mounting.
- ◆Reflow temperature profile
Apply reflow temperature profile within the specified conditions. In individual applications, the actual temperature may vary, depending on solder paste type, volume/thickness and PCB size/thickness. Consult your solder paste and equipment manufacturer for specific recommendations.

[INSTRUCTIONS FOR PCB HANDLING AFTER MOUNTING THE CONNECTOR]

- ◆Load to PCB
- Splitting a large PCB into several pieces
- Screwing the PCB
Avoid the handling described above so that no force is exerted on the PCB during the assembly process. Otherwise, the connector may become defective.
- ◆Amount of Warp
The warp of a 100mm wide PCB should be 0.5 mm or less. The warp of PCB suffers stress on connector and the connector may become defective.

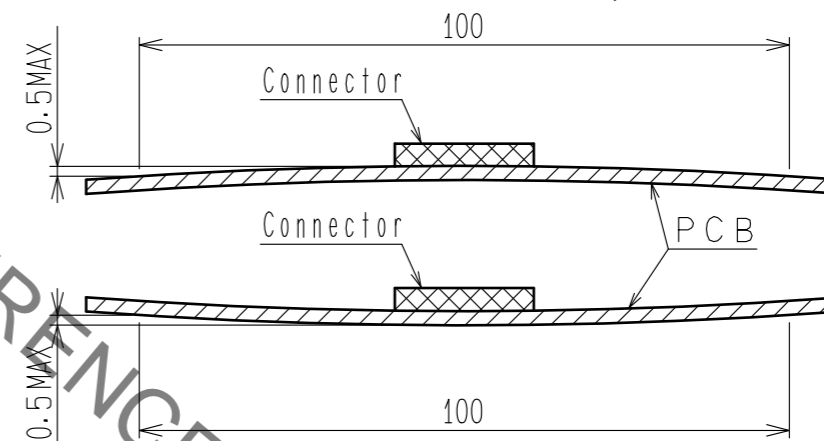

[Other instructions]

- ◆Instructions on manual soldering
Follow the instructions shown below when soldering the connector manually during repair work, etc.
 1. Do not perform manual soldering with the FPC inserted into the connector.
 2. Do not heat the connector excessively. Be very careful not to let the soldering iron contact any parts other than connector leads. Otherwise, the connector may be deformed or melt.
 3. Do not supply excessive solder (or flux).
If excessive solder (or flux) is supplied on the terminals, solder or flux may adhere to the contacts or rotating parts of the actuator, resulting in poor contact or a rotation failure of the actuator. Supplying excessive solder to the metal fittings may hinder actuator rotation, resulting in breakage of the connector.

<INSTRUCTION MANUAL (4)>

HRS	DRAWING NO.	EDC-365495-00-00
	PART NO.	FH43MW-**S-0.25SHW<10>
	CODE NO.	CL580
		8/8

Mouser Electronics

Authorized Distributor

Click to View Pricing, Inventory, Delivery & Lifecycle Information:

[Hirose Electric:](#)

[FH43MW-55S-0.25SHW\(10\)](#)