

Aug.1.2021 Copyright 2021 HIROSE ELECTRIC CO., LTD. All Rights Reserved.
In case of consideration for using Automotive equipment / device which demand high reliability, kindly contact our sales window correspondents.

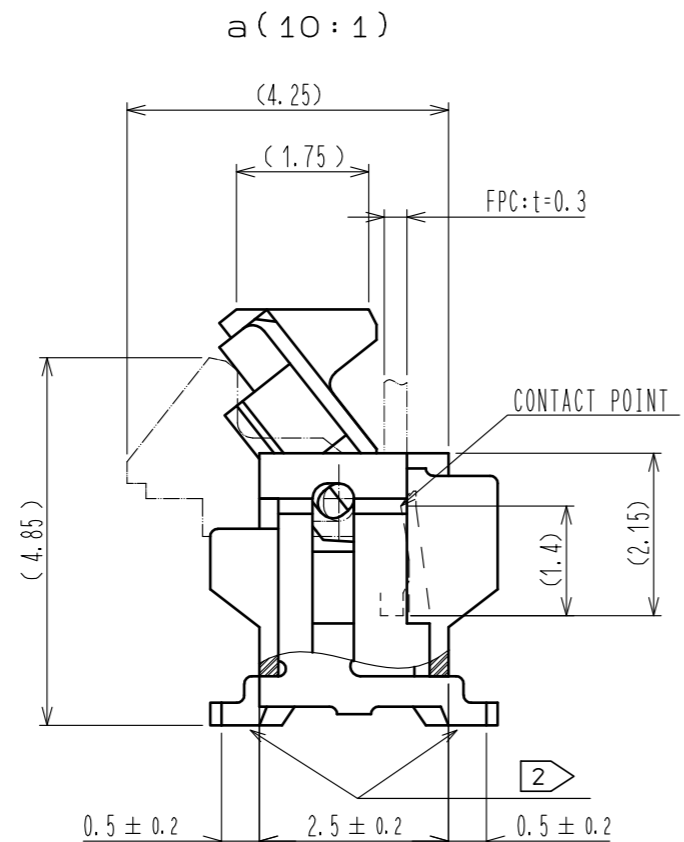
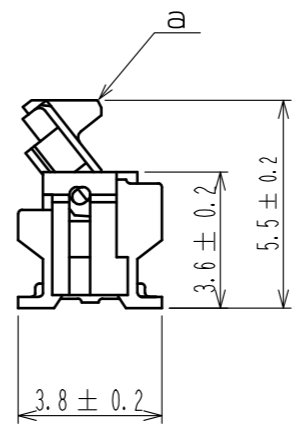
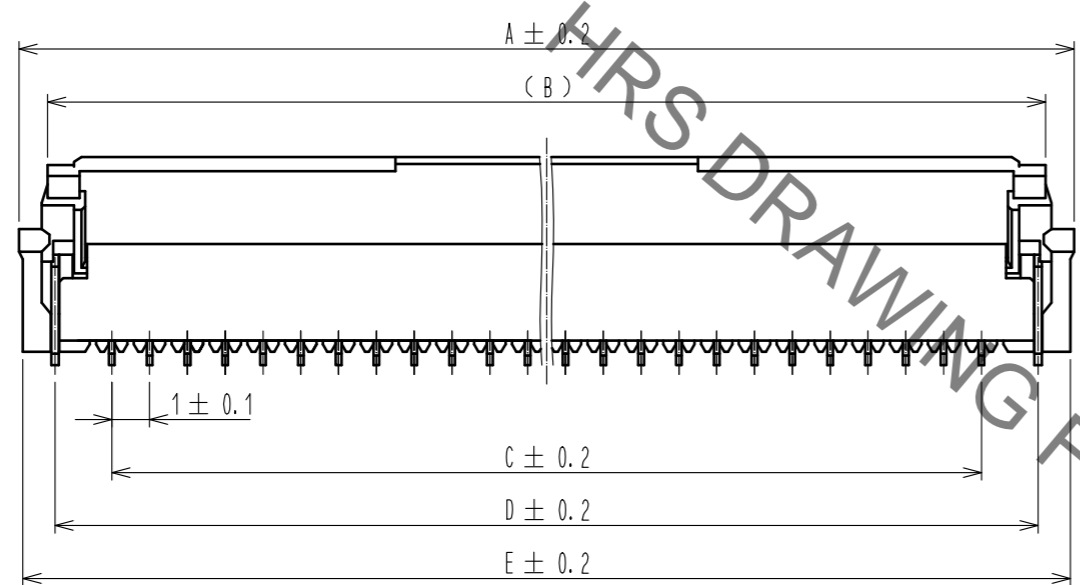
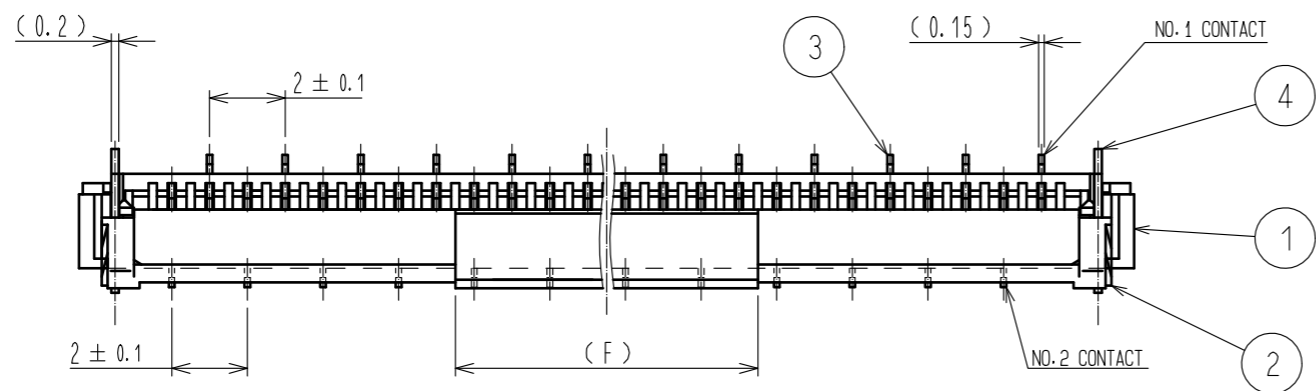

- NOTE 1 THE DIMENSIONS IN PARENTHESES ARE FOR REFERENCE.
 2 LEAD CO-PLANARITY SHALL BE 0.1 MAX.
 3 SEE DIMENSION TABLE IN THE APPENDIX.
 4 DIFFERENCES OF THE GOLD PLATED AREA DO NOT INFLUENCE ON THE PRODUCT PERFORMANCE.
 5 'n' REPRESENTS THE NUMBER OF CONTACTS.

HRS DRAWING FOR REFERENCE

3	PHOSPHOR BRONZE	(CONTACT AREA, LEAD) GOLD PLATING 0.05μmMIN OVER NICKEL 1μmMIN (OTHER) NICKEL PLATING 1μmMIN	8 (CONNECTOR)						
2	PPS	(DEEP BROWN) UL94V-0	7 POLYSTYRENE						
1	PA	(BEIGE) UL94V-0	6 POLYESTER						
			5 POLYSTYRENE						
			4 BRASS	TIN PLATING 1μm MIN-OVER NICKEL 1μm MIN.					
NO.	MATERIAL	FINISH . REMARKS	NO.	MATERIAL	FINISH . REMARKS				
UNITS	mm	SCALE	5 : 1	COUNT	7	DESCRIPTION OF REVISIONS	DESIGNED	CHECKED	DATE
						DIS-F-00004925	SE. YOKOYAMA	HS. SAKAMOTO	20190718
HRS HIROSE ELECTRIC CO., LTD.		APPROVED	NF. MIYAZAKI	20150916	DRAWING NO.		EDC-366184-00-00		
		CHECKED	HS. SAKAMOTO	20150915	PART NO.		FH12- ** S-1SVA(54)		
		DESIGNED	SG. MASAKI	20150915	CODE NO.		CL586		
		DRAWN	SG. MASAKI	20150915					

Aug.1.2021 Copyright 2021 HIROSE ELECTRIC CO., LTD. All Rights Reserved.
In case of consideration for using Automotive equipment / device which demand high reliability, kindly contact our sales window correspondents.

RECOMMENDED PCB MOUNTING PATTERN

NUMBER OF CONTACTS: EVEN NUMBER

NUMBER OF CONTACTS: ODD NUMBER

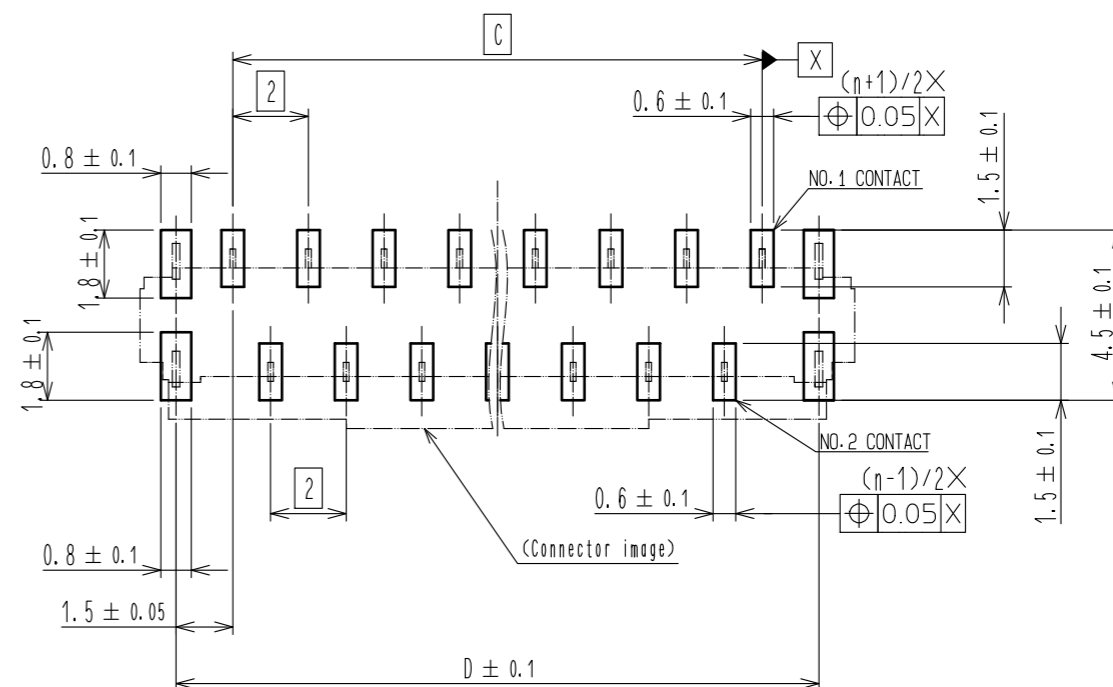
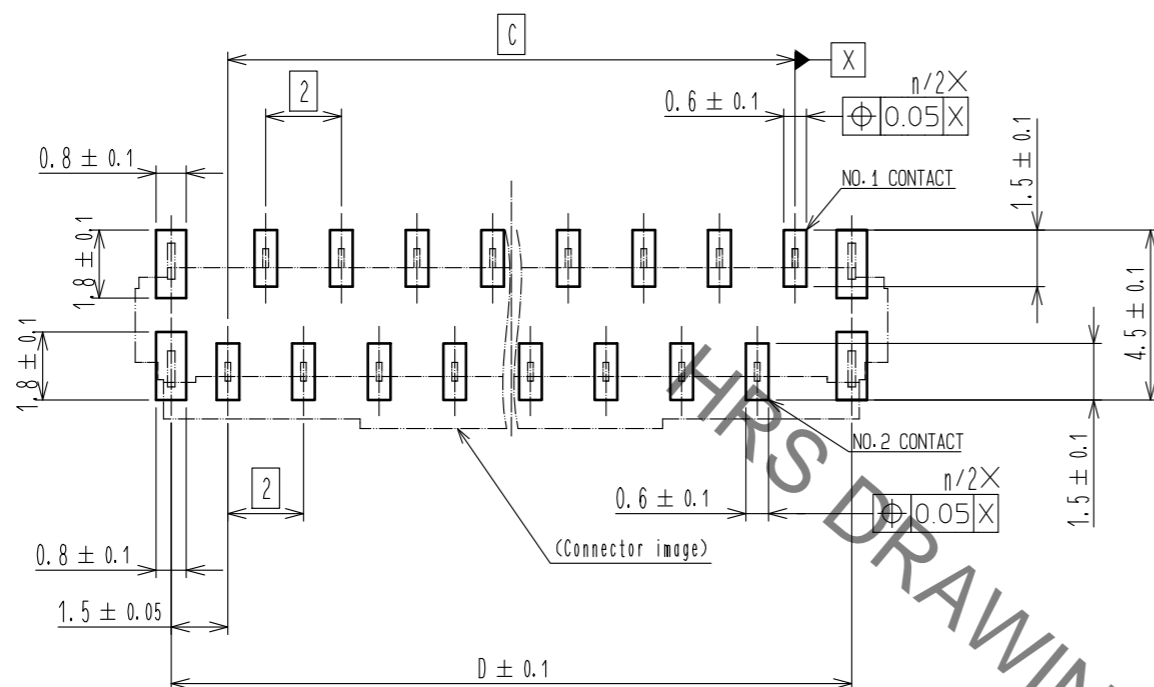

RECOMMENDED STENCIL PATTERN (RECOMMENDED STENCIL THICKNESS: t=0.15)

NUMBER OF CONTACTS: EVEN NUMBER

NUMBER OF CONTACTS: ODD NUMBER

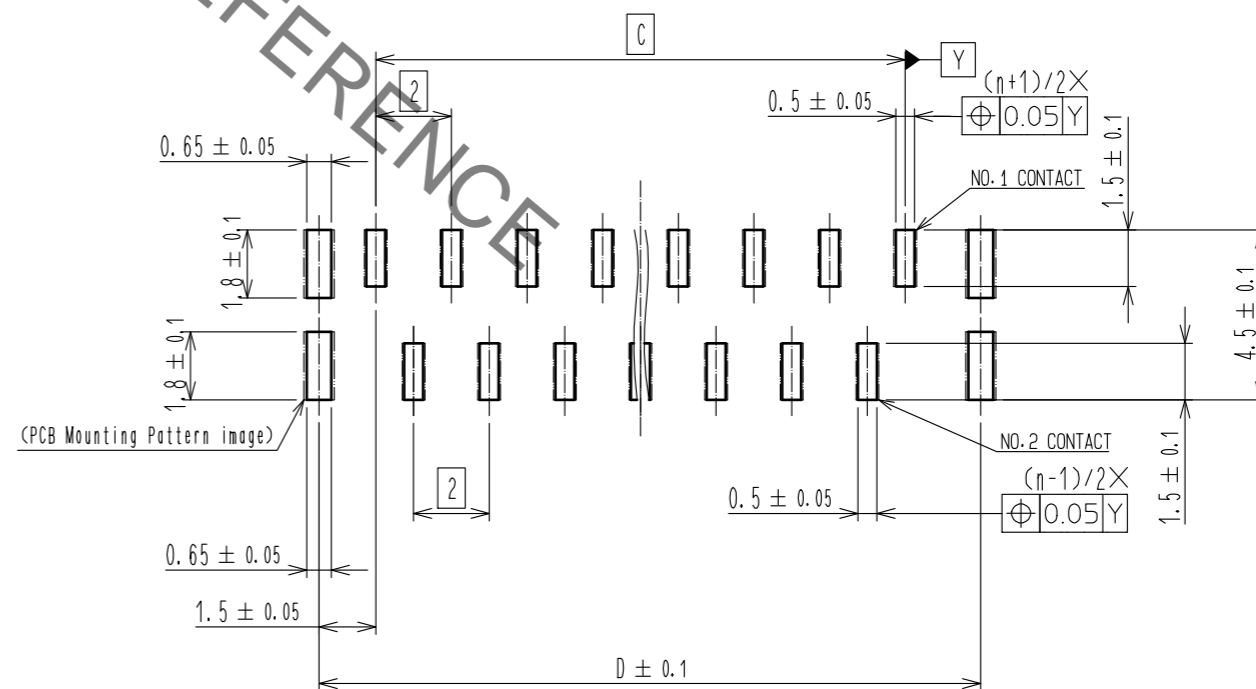
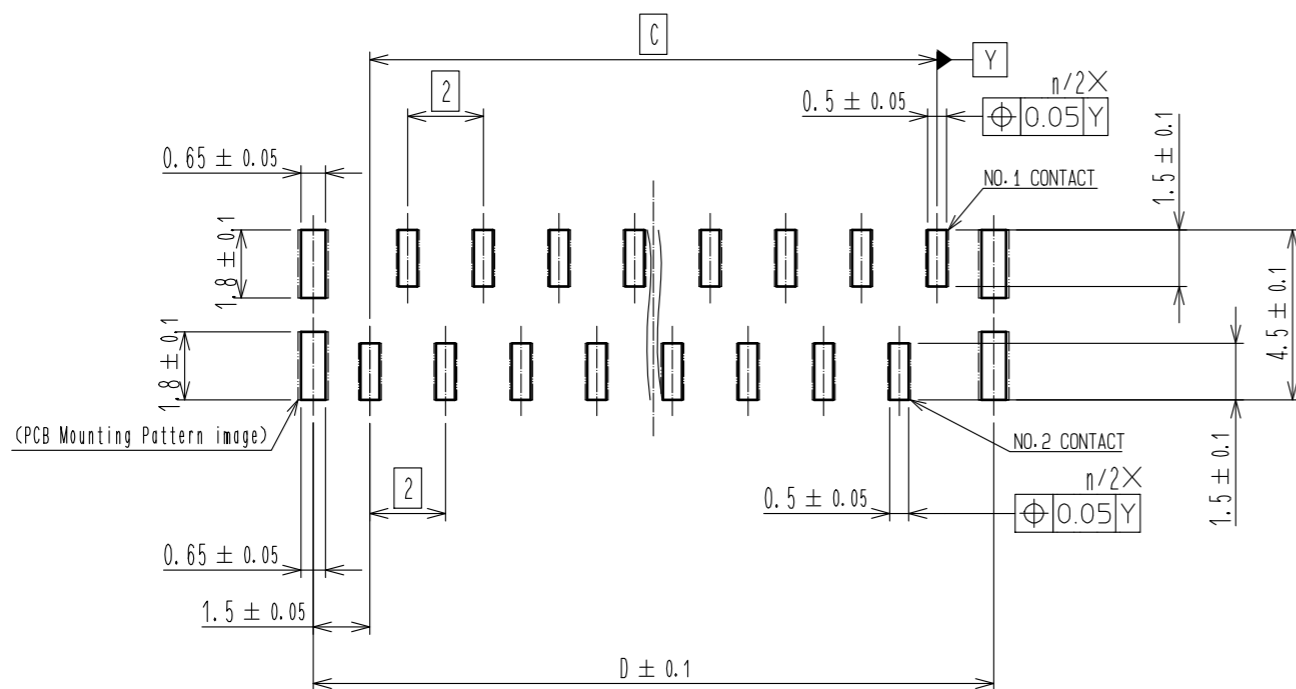

HRS	DRAWING NO.	EDC-366184-00-00
	PART NO.	FH12-***S-1SVA(54)
	CODE NO.	CL586
		2/5

Aug.1.2021 Copyright 2021 HIROSE ELECTRIC CO., LTD. All Rights Reserved.
In case of consideration for using Automotive equipment / device which demand high reliability, kindly contact our sales window correspondents.

RECOMMENDED FPC/FFC (15:1)

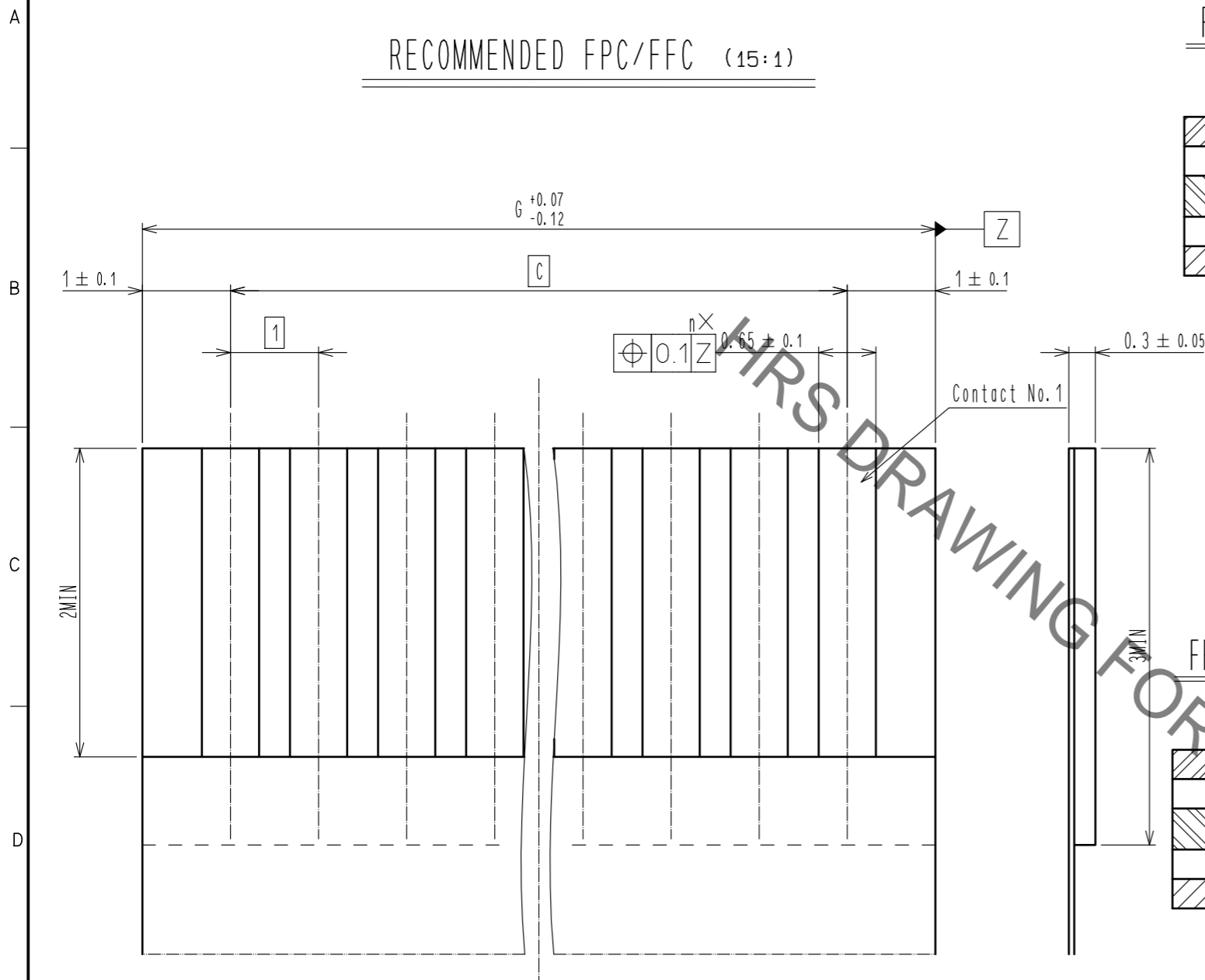

FPC CONFIGURATION (REFERENCE EXAMPLE) (SCALE:FREE)

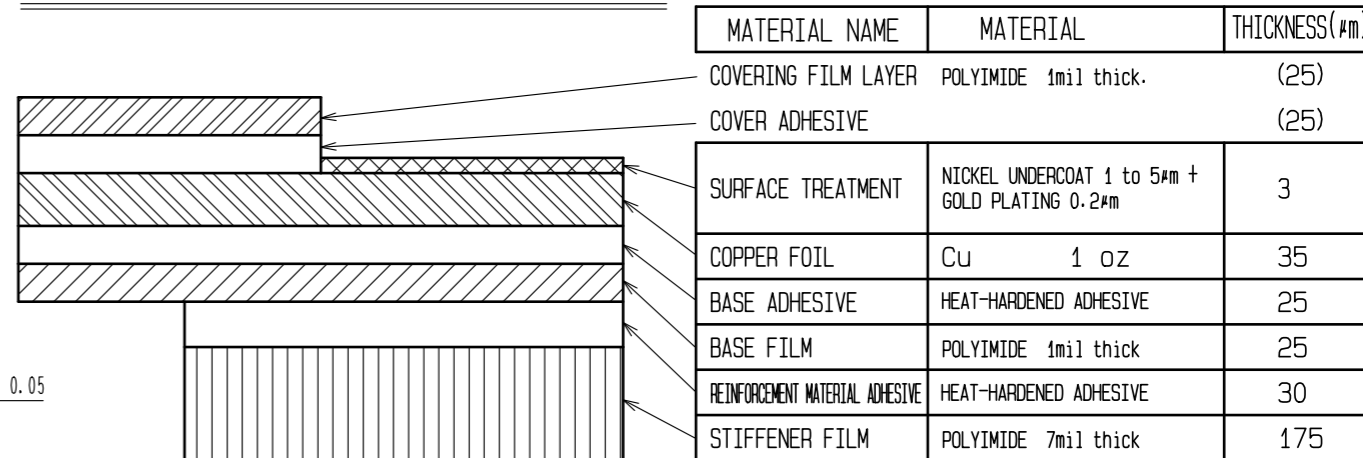

MATERIAL NAME	MATERIAL	THICKNESS(μm)
COVERING FILM LAYER	POLYIMIDE 1mil thick.	(25)
COVER ADHESIVE		(25)
SURFACE TREATMENT	NICKEL UNDERCOAT 1 to 5μm + GOLD PLATING 0.2μm	3
COPPER FOIL	CU 1 oz	35
BASE ADHESIVE	HEAT-HARDENED ADHESIVE	25
BASE FILM	POLYIMIDE 1mil thick	25
REINFORCEMENT MATERIAL ADHESIVE	HEAT-HARDENED ADHESIVE	30
STIFFENER FILM	POLYIMIDE 7mil thick	175

FFC CONFIGURATION (REFERENCE EXAMPLE) (SCALE:FREE)

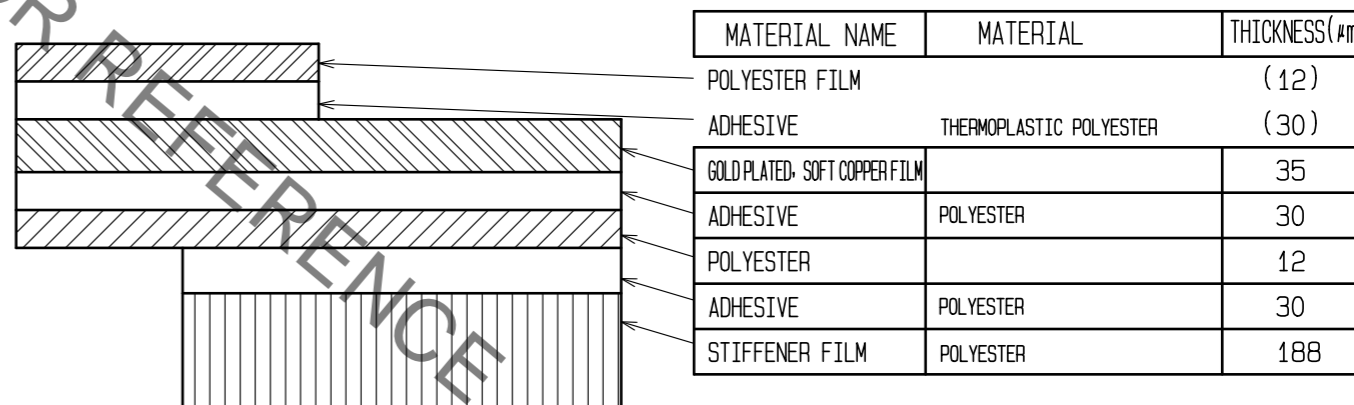

MATERIAL NAME	MATERIAL	THICKNESS(μm)
POLYESTER FILM		(12)
ADHESIVE	THERMOPLASTIC POLYESTER	(30)
GOLD PLATED SOFT COPPER FILM		35
ADHESIVE	POLYESTER	30
POLYESTER		12
ADHESIVE	POLYESTER	30
STIFFENER FILM	POLYESTER	188



DRAWING NO.	EDC-366184-00-00
PART NO.	FH12-**S-1SVA(54)
CODE NO.	CL586

3/5

Aug.1.2021 Copyright 2021 HIROSE ELECTRIC CO., LTD. All Rights Reserved.
 In case of consideration for using Automotive equipment / device which demand high reliability, kindly contact our sales window correspondents.

EMBOSSED CARRIER TAPE DIMENSION (2:1)

TAPE WIDTH : 32mm MIN

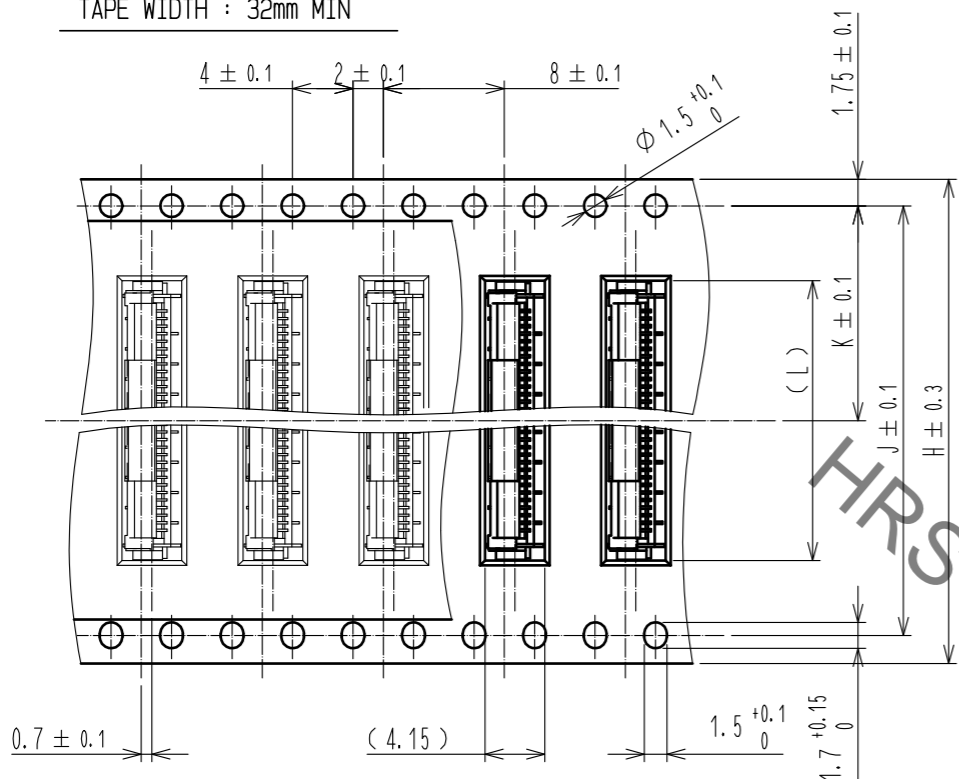

DIRECTION OF UNREELING

TAPE WIDTH : 24mm MAX

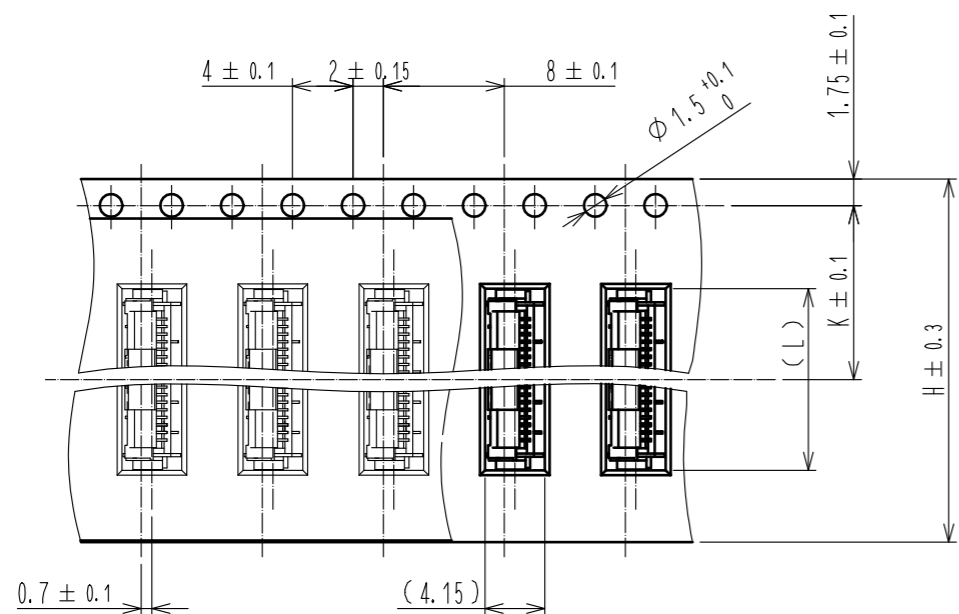

DIRECTION OF UNREELING

REEL DIMENSION(SHOW AS BELOW)(FREE)

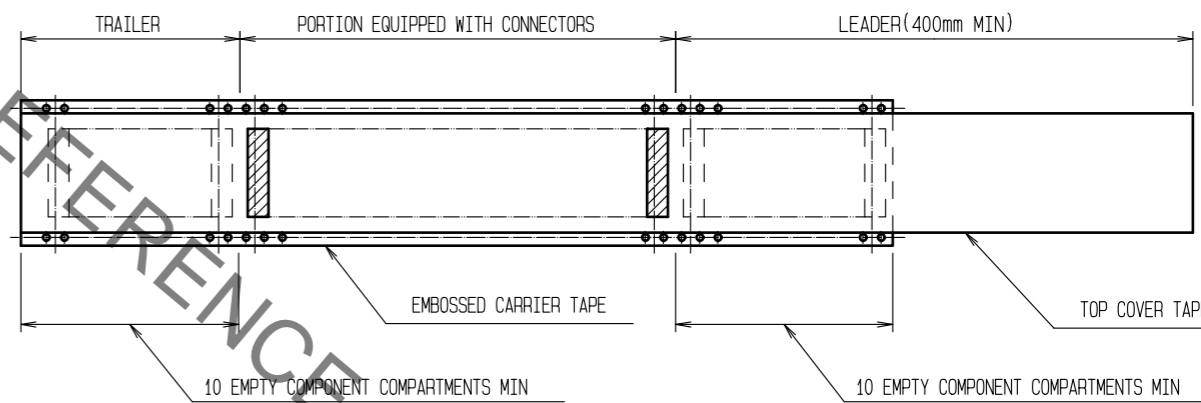
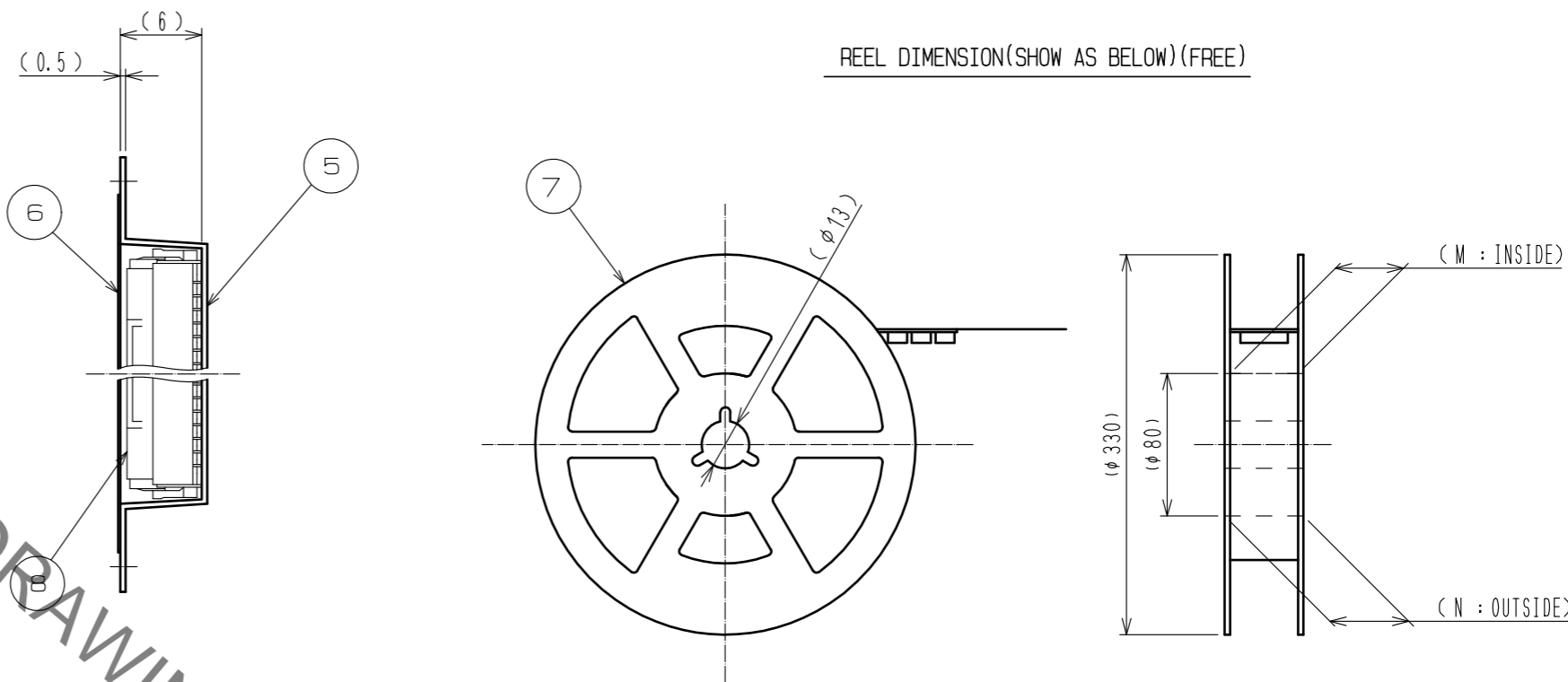

NOTE 6 1REEL : 1000 CONNECTORS.

DRAWING FOR PACKING

HRS

DRAWING NO.	EDC-366184-00-00
PART NO.	FH12-***S-1SVA(54)
CODE NO.	CL586

4/5

Aug.1.2021 Copyright 2021 HIROSE ELECTRIC CO., LTD. All Rights Reserved.
 In case of consideration for using Automotive equipment / device which demand high reliability, kindly contact our sales window correspondents.

	PART NO.	CODE NO.	NUMBER OF CONTACTS	DIMENSION TABLE OF CONNECTOR, FPC, FFC, PCB MOUNTING PATTERN AND STENCIL PATTERN							DIMENSION TABLE OF DRAWING FOR PACKING					
				A	B	C	D	E	F	G	H	J	K	L	M	N
⚠	FH12- 6S-1SVA(54)	CL586-0822-0-54	6	9.9	8.4	5	8	9.7	4	7	24	—	11.5	10	25.4	29.4
⚠	FH12- 7S-1SVA(54)	CL586-0823-0-54	7	10.9	9.4	6	9	10.7	4	8	24	—	11.5	11	25.4	29.4
⚠	FH12- 8S-1SVA(54)	CL586-0824-0-54	8	11.9	10.4	7	10	11.7	4	9	24	—	11.5	12	25.4	29.4
⚠	FH12-16S-1SVA(54)	CL586-0825-0-54	16	19.9	18.4	15	18	19.7	8	17	32	28.4	14.2	20	33.4	37.4
⚠	FH12-20S-1SVA(54)	CL586-0826-0-54	20	23.9	22.4	19	22	23.7	8	21	44	40.4	20.2	24	45.4	49.4
⚠	FH12-22S-1SVA(54)	CL586-0827-0-54	22	25.9	24.4	21	24	25.7	8	23	44	40.4	20.2	26	45.4	49.4
⚠	FH12-24S-1SVA(54)	CL586-0828-0-54	24	27.9	26.4	23	26	27.7	8	25	44	40.4	20.2	28	45.4	49.4

THIS DRAWING FOR REFERENCE

HRS	DRAWING NO.	EDC-366184-00-00
	PART NO.	FH12-**S-1SVA(54)
	CODE NO.	CL586
		⚠ 5/5

Mouser Electronics

Authorized Distributor

Click to View Pricing, Inventory, Delivery & Lifecycle Information:

[Hirose Electric:](#)

[FH12-24S-1SVA\(54\)](#)