

Sep.1.2021 Copyright 2021 HIROSE ELECTRIC CO., LTD. All Rights Reserved.  
In case of consideration for using Automotive equipment / device which demand high reliability, kindly contact our sales window correspondents.

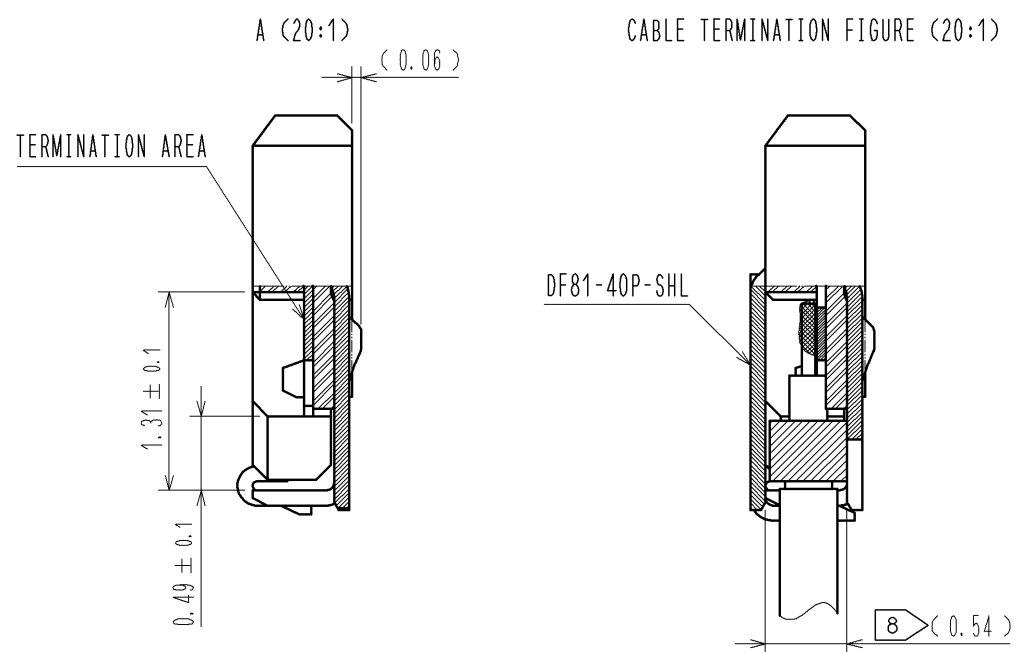
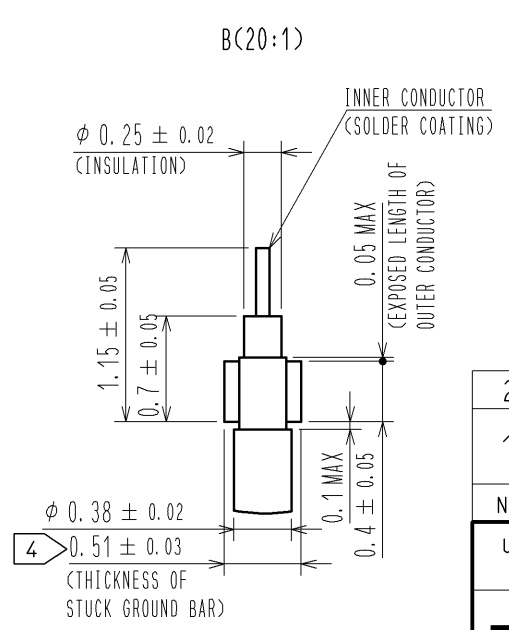
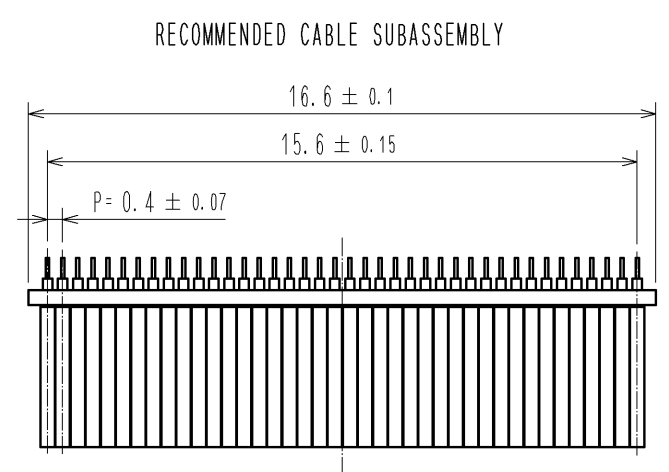
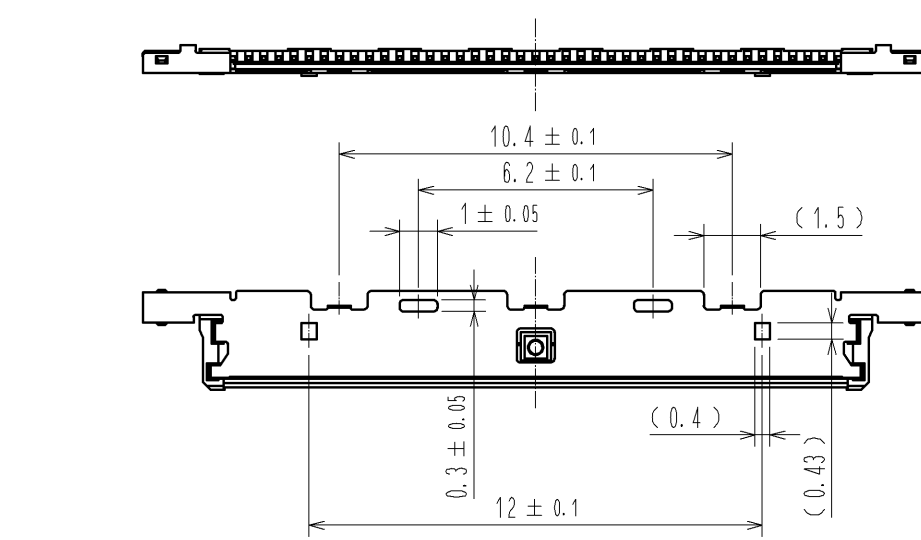
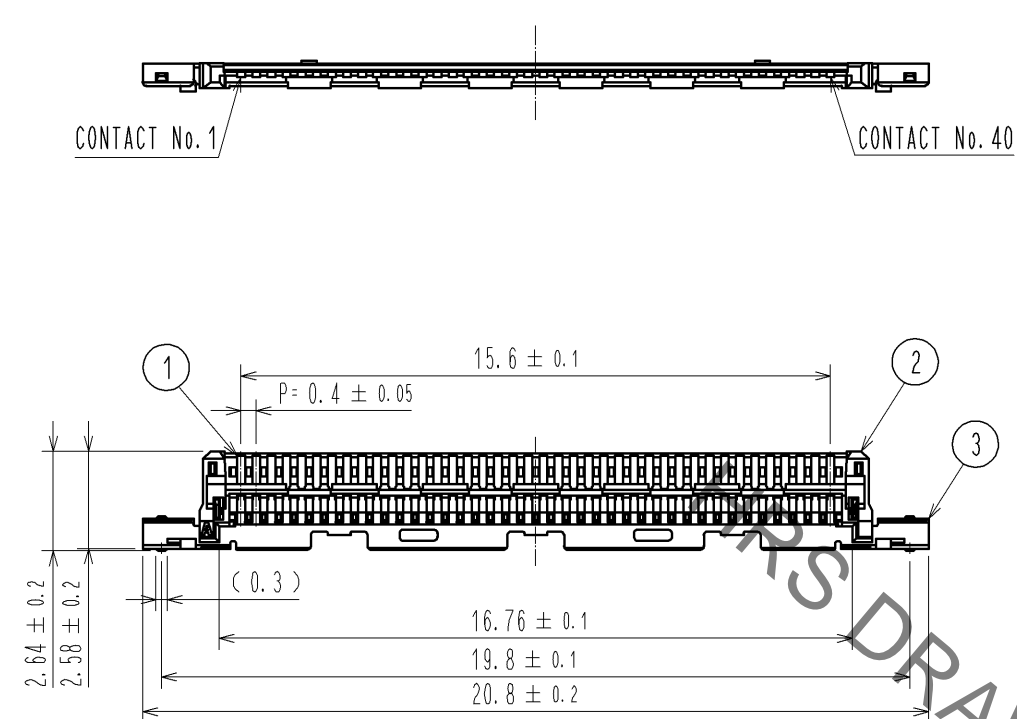

- NOTES**
1. APPLICABLE CABLE: MICRO COAXIAL CABLE(AWG#36~AWG#46)
  2. THIS CONNECTOR IS NOT HOT PLUGGABLE. MATE AND UNMATE WHITE WHILE THE POWER IS OFF.
  3. THE ASSEMBLY IS COMPLETED BY COMBINING THREE PARTS 'CONNECTOR UNIT, METAL SHIELDING' AND 'LATCH'. REFER TO THE TABLE FOR EACH ITEM No. PART NAME, PART No AND CODE No.
  4. SOLDER A GROUND BAR WITH AN EXTERNAL CONDUCTOR OF THE CABLE ABOUT STICKING A GROUND BAR TOGETHER.
  5. PLEASE CONSULT ABOUT THE USE OF THE POTTING AND KAPTON TAPE SEPARATELY.
  6. PLEASE ATTACH A LATCH BEFORE INCORPORATING SHELL. PLEASE REFER TO ASSEMBLY MANUAL FOR DETAILS.
  7. THE DIMENSIONS IN PARENTHESES ARE FOR REFERENCE.
  8. TOTAL THICKNESS OF ENCLOSED MATERIALS : 0.54mm MAX. THICKNESS EXCEEDING THE DIMENSION DOES NOT ALLOW THE METAL SHIELDING TO BE COMPLETELY FIT IN TO THE CONNECTOR.

ITEM No.	PART NAME	PART No.	CODE No.
1, 2, 3	CONNECTOR UNIT	DF81D-40P-0.4SD(51)	CL662-8120-1-51
-	METAL SHIELDING	DF81-40P-SHL	CL662-8108-6-00
-	LATCH	DF81-40P-LCH	CL662-8109-9-00

NO.	MATERIAL	FINISH . REMARKS	NO.	MATERIAL	FINISH . REMARKS
2	LCP	UL94V-0, BLACK	6	PS	BLACK
1	PHOSPHER BRONZE	CONTACT AREA : Au PLATING 0.1μm min TERMINATION AREA : Au PLATING 0.1μm min UNDER PLATING : Ni PLATING 1 μm min	5	POLYESTER	CLEAR
			4	PS	CLEAR
			3	SUS	CONTACT AREA : Au PLATING 0.05μm min SOLDERING AREA : Au PLATING 0.05μm min UNDER PLATING : Ni PLATING 0.2 μm min

  

UNITS	SCALE	COUNT	DESCRIPTION OF REVISIONS	DESIGNED	CHECKED	DATE
mm	5 : 1	△				

APPROVED	DATE	DRAWING NO.
TS. SAKATA	13.05.14	EDC3-351669-02
CHECED	DATE	PART NO.
TS. SAKATA	13.05.14	DF81D-40P-0.4SD(51)
DESIGNED	DATE	CODE NO.
AH. MIYAZAKI	13.05.14	CL662-8120-1-51
DRAWN	DATE	
AH. MIYAZAKI	13.05.14	

Sep.1.2021 Copyright 2021 HIROSE ELECTRIC CO., LTD. All Rights Reserved.  
 In case of consideration for using Automotive equipment / device which demand high reliability, kindly contact our sales window correspondents.

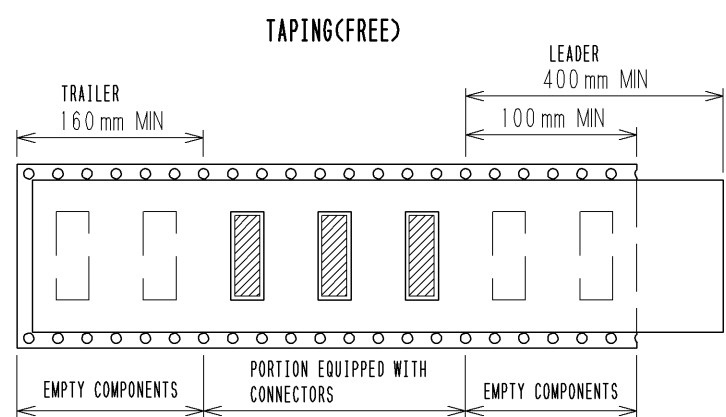
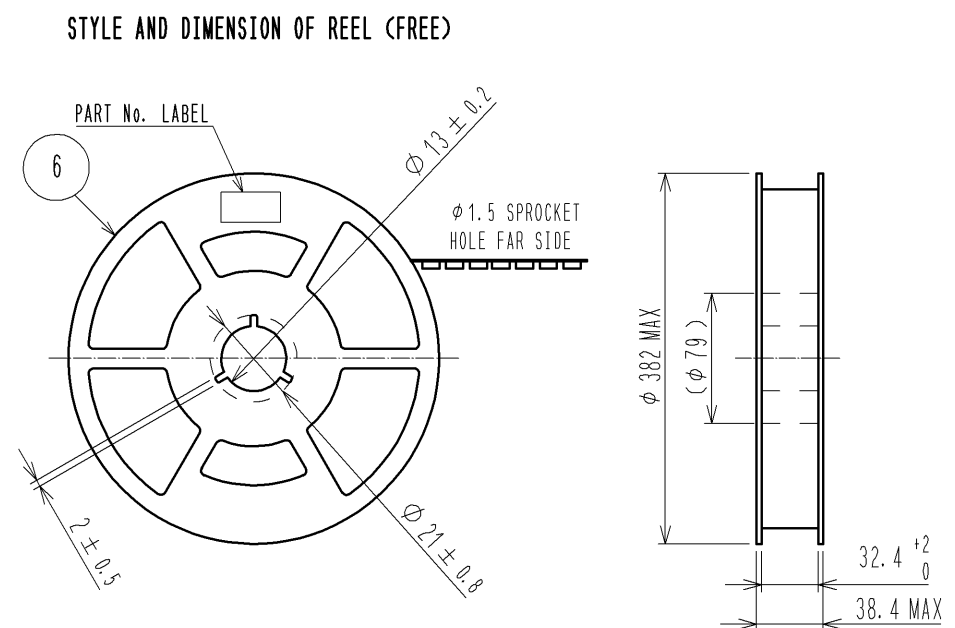
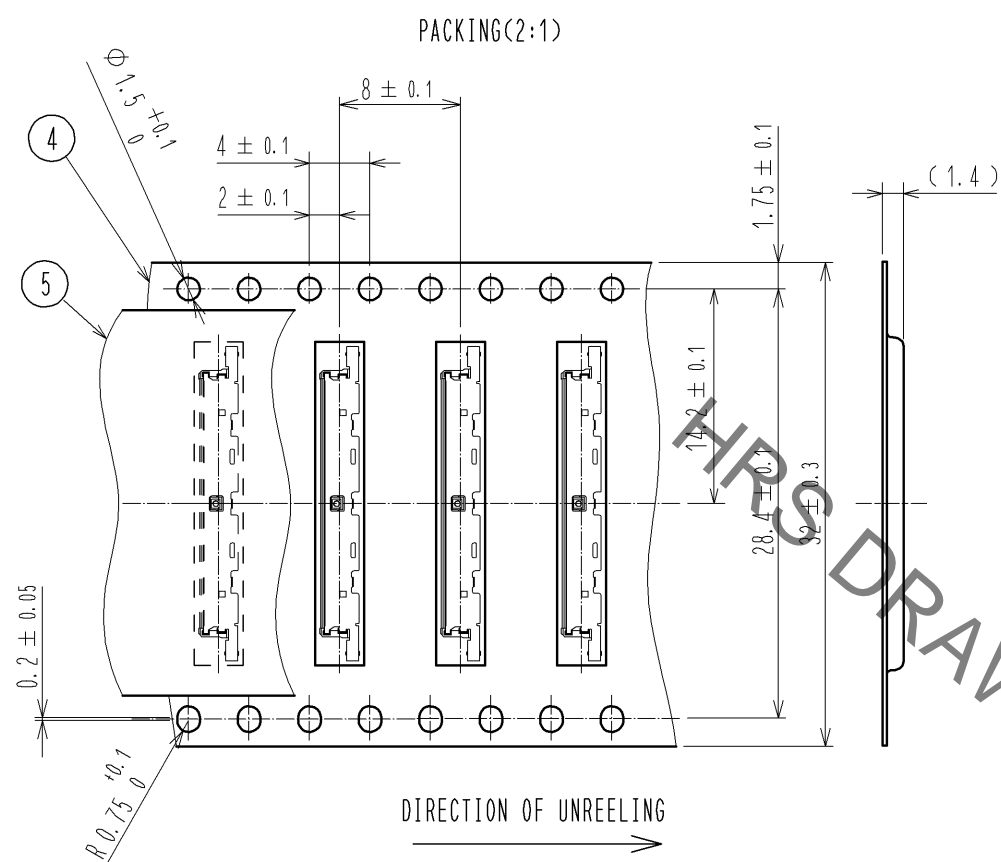

DETAIL OF PART No. LABEL

生産月日	年月日
図番	CL662-8120-1-51
品名	DF81D-40P-0.4SD(51)
納入数量	8000個
納入者	ヒロセ電機株式会社

SUPPLIER  
 QUANTITY  
 PART No.  
 CODE No.  
 DATE OF MANUFACTURED

<b>HRS</b>	DRAWING NO.	EDC3-351669-02
	PART NO.	DF81D-40P-0.4SD(51)
	CODE NO.	CL662-8120-1-51
		△ 2/2

# Mouser Electronics

Authorized Distributor

Click to View Pricing, Inventory, Delivery & Lifecycle Information:

[Hirose Electric:](#)

[DF81D-40P-0.4SD\(51\)](#)