

Sep.1.2021 Copyright 2021 HIROSE ELECTRIC CO., LTD. All Rights Reserved.
In case of consideration for using Automotive equipment / device which demand high reliability, kindly contact our sales window correspondents.

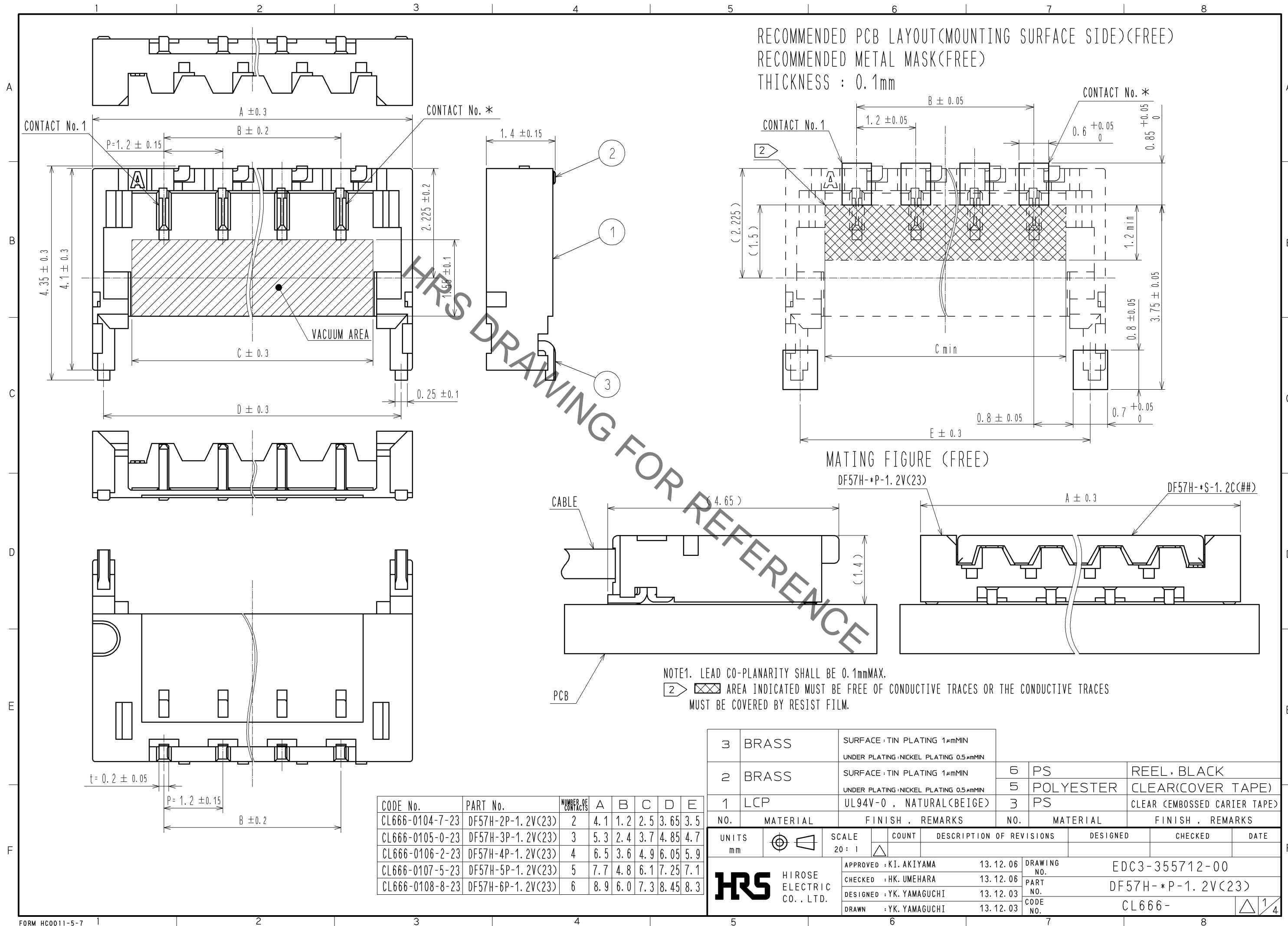

RECOMMENDED PCB LAYOUT(MOUNTING SURFACE SIDE)(FREE)
RECOMMENDED METAL MASK(FREE)
THICKNESS : 0.1mm

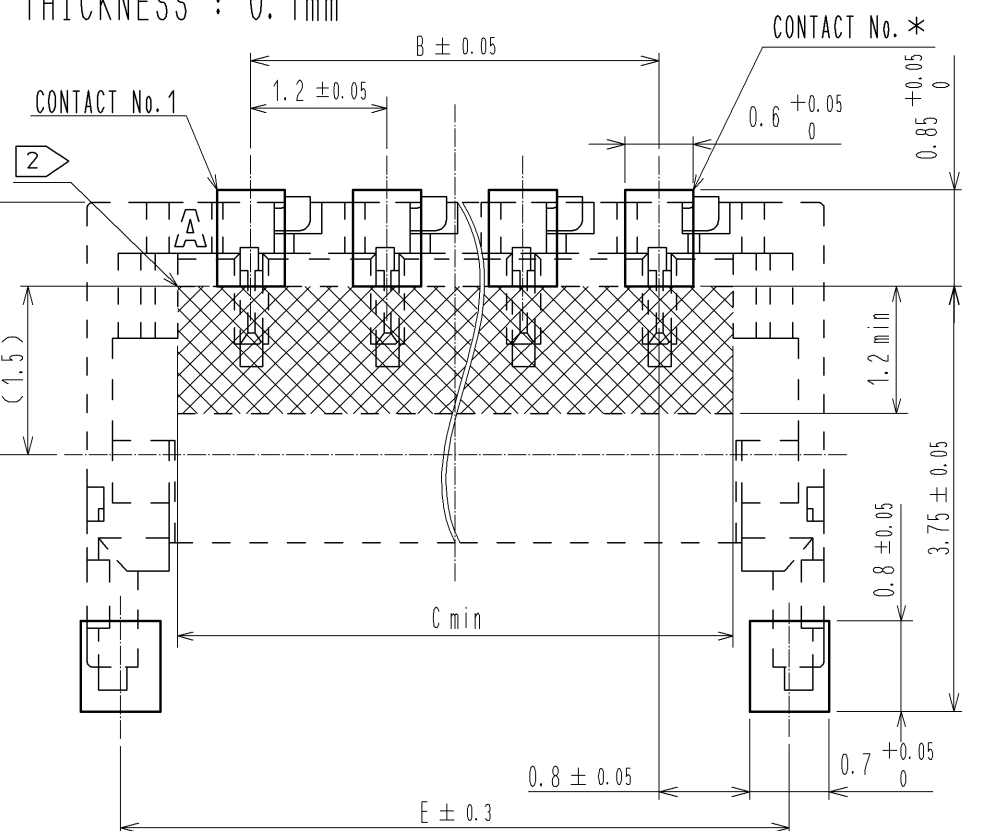

MATING FIGURE (FREE)

DF57H-*P-1.2V(23)

DF57H-*S-1.2C(##)

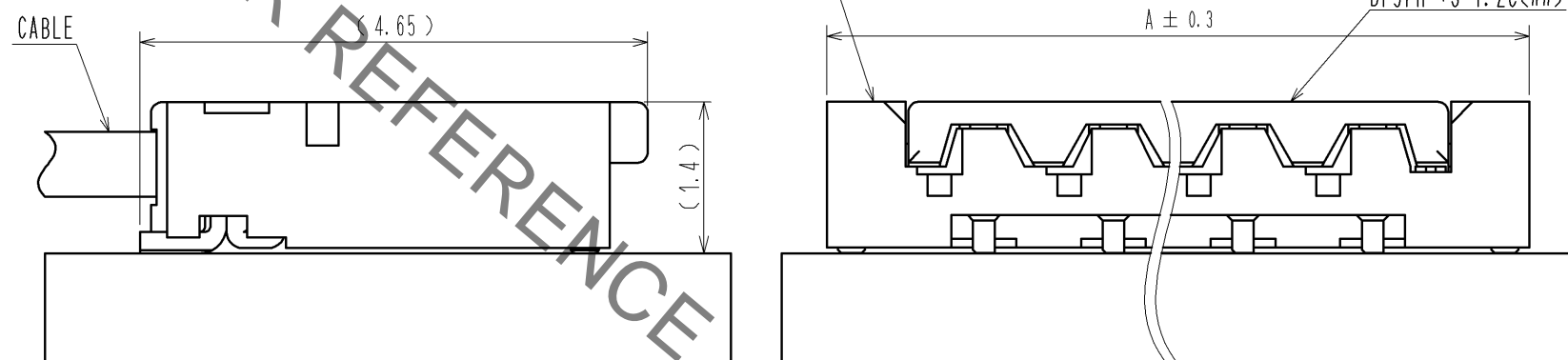

NOTE1. LEAD CO-PLANARITY SHALL BE 0.1mmMAX.

2 AREA INDICATED MUST BE FREE OF CONDUCTIVE TRACES OR THE CONDUCTIVE TRACES MUST BE COVERED BY RESIST FILM.

CODE No.	PART No.	NUMBER OF CONTACTS	A	B	C	D	E
CL666-0104-7-23	DF57H-2P-1.2V(23)	2	4.1	1.2	2.5	3.65	3.5
CL666-0105-0-23	DF57H-3P-1.2V(23)	3	5.3	2.4	3.7	4.85	4.7
CL666-0106-2-23	DF57H-4P-1.2V(23)	4	6.5	3.6	4.9	6.05	5.9
CL666-0107-5-23	DF57H-5P-1.2V(23)	5	7.7	4.8	6.1	7.25	7.1
CL666-0108-8-23	DF57H-6P-1.2V(23)	6	8.9	6.0	7.3	8.45	8.3

NO.	MATERIAL	FINISH	REMARKS	NO.	MATERIAL	FINISH	REMARKS
3	BRASS		SURFACE : TIN PLATING 1μmMIN UNDER PLATING : NICKEL PLATING 0.5μmMIN	6	PS		REEL · BLACK
2	BRASS		SURFACE : TIN PLATING 1μmMIN UNDER PLATING : NICKEL PLATING 0.5μmMIN	5	POLYESTER		CLEAR(COVER TAPE)
1	LCP		UL94V-0 , NATURAL(BEIGE)	3	PS		CLEAR (EMBOSSED CARRIER TAPE)

UNITS	SCALE	COUNT	DESCRIPTION OF REVISIONS	DESIGNED	CHECKED	DATE
mm	20 : 1	△				

APPROVED : KI. AKIYAMA	13.12.06	DRAWING NO.	EDC3-355712-00
CHECKED : HK. UMEHARA	13.12.06	PART NO.	DF57H-*P-1.2V(23)
DESIGNED : YK. YAMAGUCHI	13.12.03	CODE NO.	CL666-
DRAWN : YK. YAMAGUCHI	13.12.03		

Sep.1.2021 Copyright 2021 HIROSE ELECTRIC CO., LTD. All Rights Reserved.
 In case of consideration for using Automotive equipment / device which demand high reliability, kindly contact our sales window correspondents.

DF57H-2P-1.2V(23)
 DF57H-3P-1.2V(23)

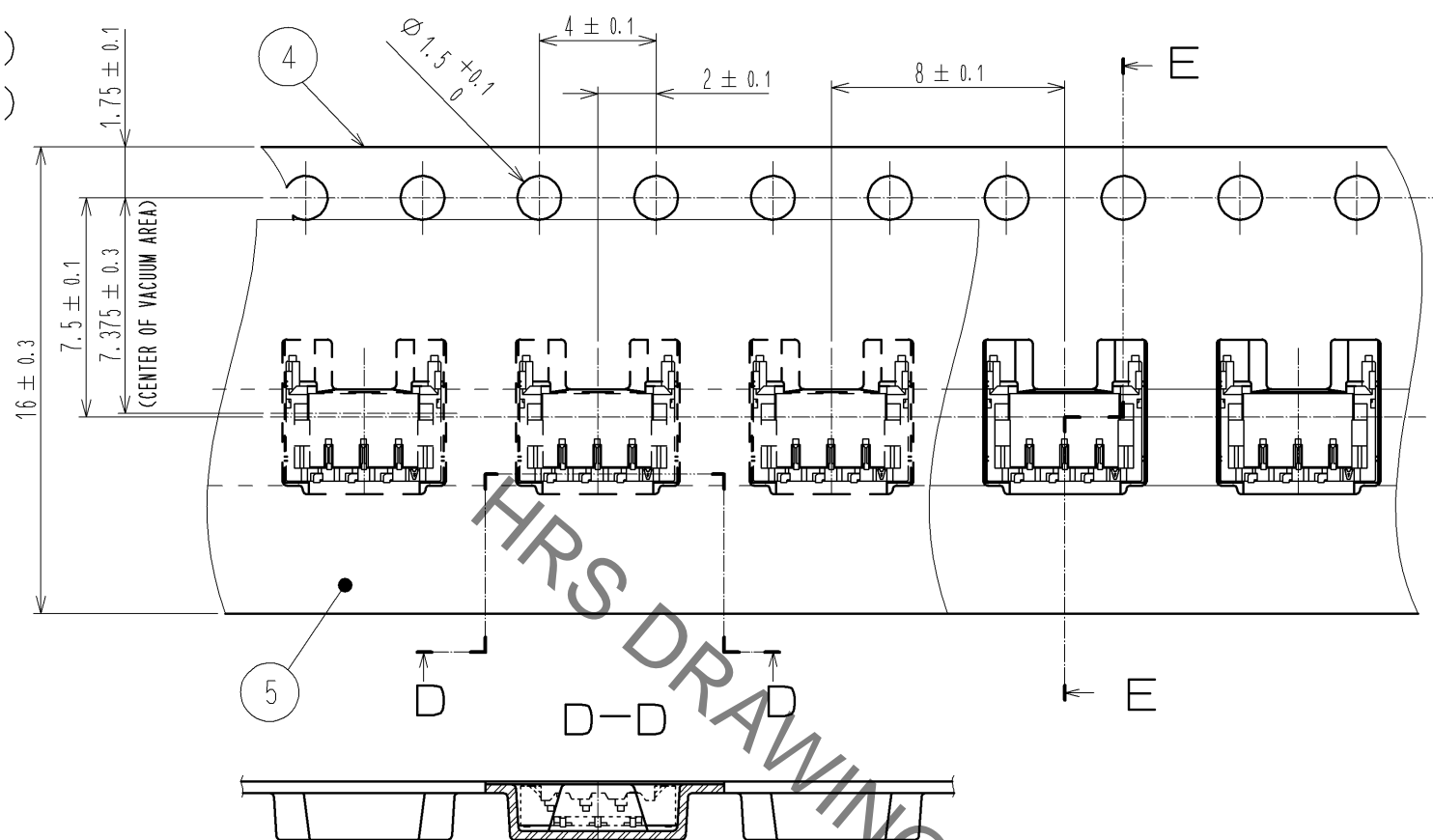

E-E

DIRECTION OF UNREELING

DF57H-4P-1.2V(23)
 DF57H-5P-1.2V(23)
 DF57H-6P-1.2V(23)

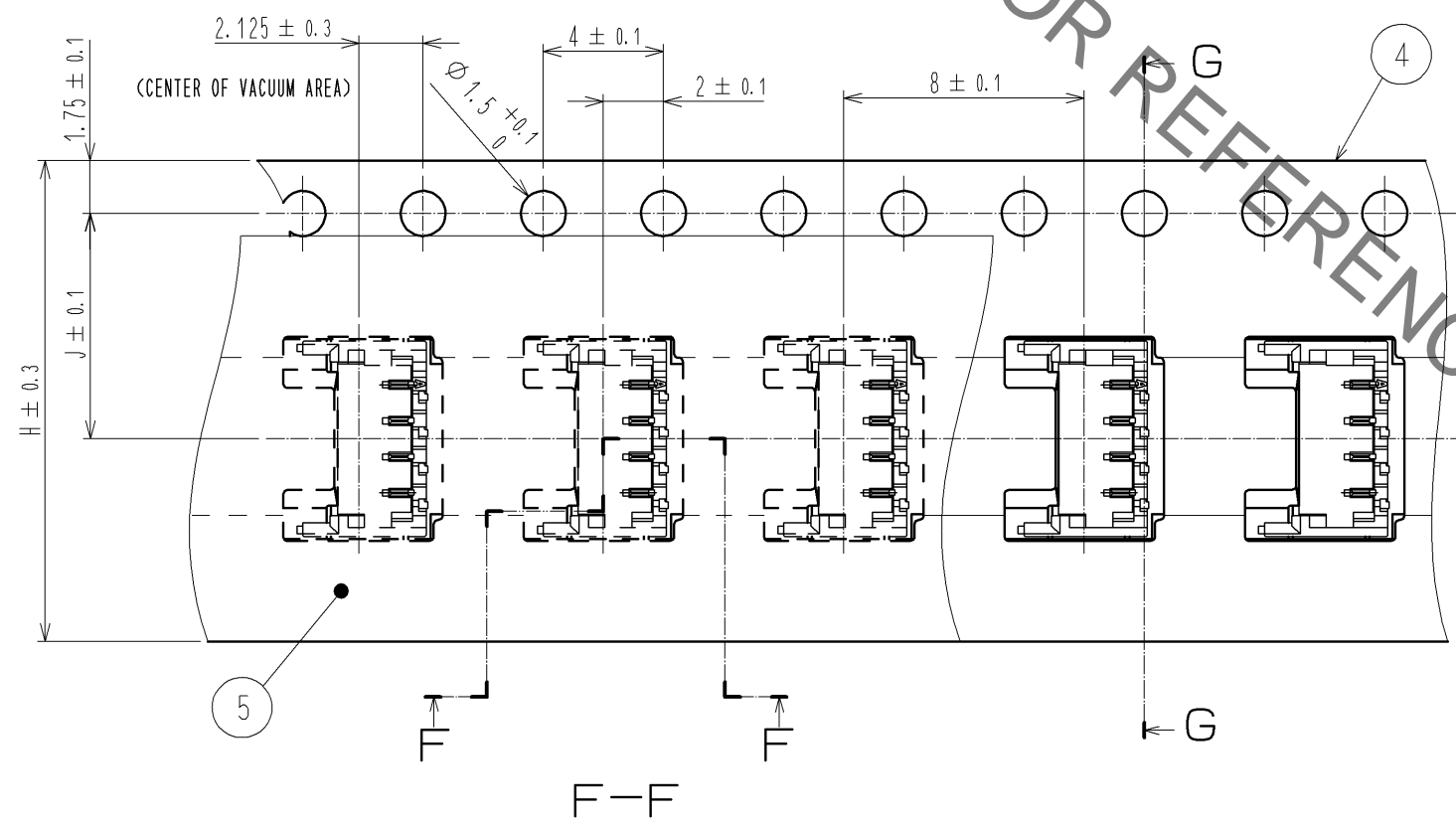

G-G

DIRECTION OF UNREELING

CODE No.	NUMBER OF CONTACTS	H	J
DF57H-4P-1.2V(23)	4	16	7.5
DF57H-5P-1.2V(23)	5	16	7.5
DF57H-6P-1.2V(23)	6	24	11.5

HRS	DRAWING NO.	EDC3-355712-00
	PART NO.	DF57H-*P-1.2V(23)
	CODE NO.	CL666- △ 2/4

Sep.1.2021 Copyright 2021 HIROSE ELECTRIC CO., LTD. All Rights Reserved.
In case of consideration for using Automotive equipment / device which demand high reliability, kindly contact our sales window correspondents.

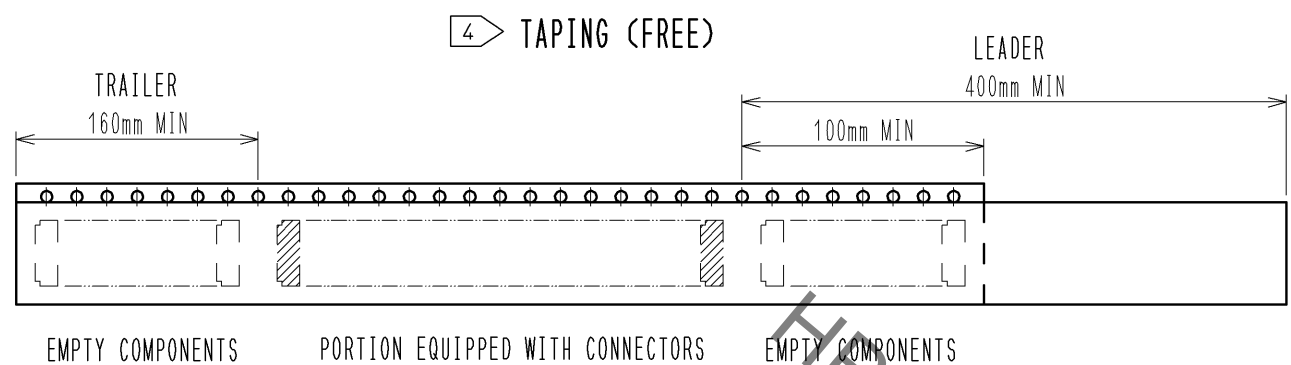

STYLE AND DIMENSION OF REEL (FREE)

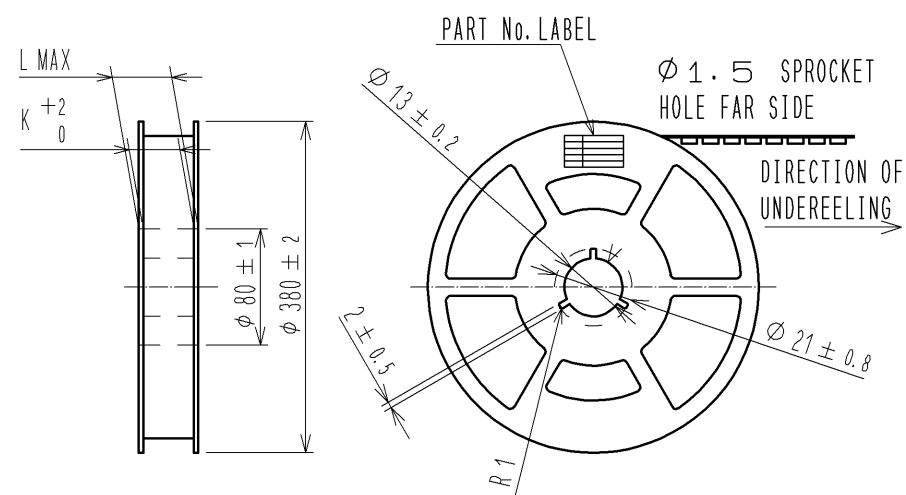

DETAIL OF PART No. LABEL

生産月日	年 月 日
☒ 番	CL666-****-**-23
品名	DF57H-*P-1.2V(23)
納入数量	5000 KO
納入者	ヒロセ電機(株)

CODE No.	NUMBER OF CONTACTS	K	L
DF57H-2P-1.2V(23)	2	16.4	22.4
DF57H-3P-1.2V(23)	3	16.4	22.4
DF57H-4P-1.2V(23)	4	16.4	22.4
DF57H-5P-1.2V(23)	5	16.4	22.4
DF57H-6P-1.2V(23)	6	24.4	30.4

REFLOW TEMPERATURE PROFILE USING LEAD-FREE SOLDER PASTE (REFERENCE)

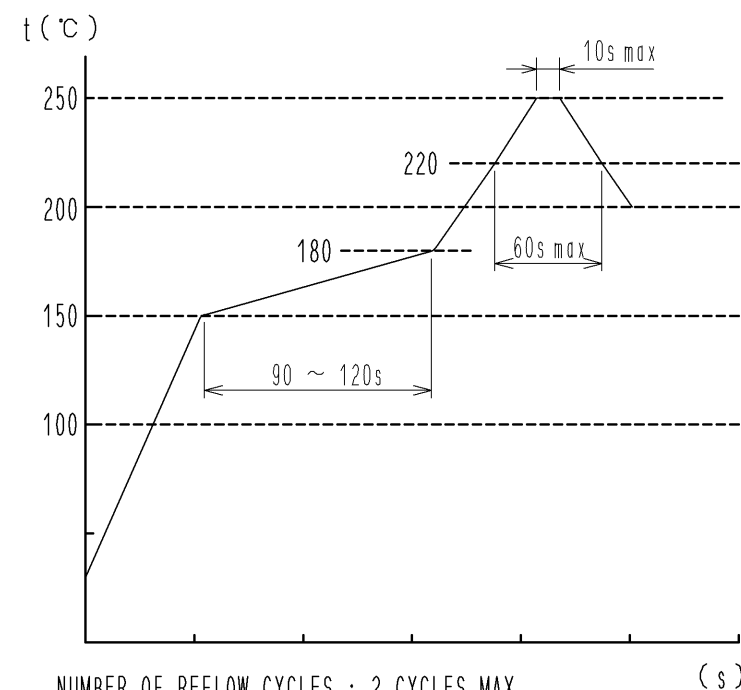

NUMBER OF REFLOW CYCLES : 2 CYCLES MAX.
THE TEMPERATURE IS MEASURED IN THE TERMINAL LEAD PART.

ADDITIONAL FACTORS, SUCH AS SOLDER PASTE TYPE, PCB SIZE AND OTHER MOUNTED COMPONENTS COULD AFFECT THE PROFILE. THEREFORE, A THOROUGH EVALUATION OF MOUNTING CONDITION IS REQUIRED PRIOR TO PRODUCTION. TEMPERATURE IS MEASURED AT CONTACT LEAD.

NOTE3. 1REEL : 5000 CONNECTORS

4 REEL TO JIS C 0806. (PACKAGING OF COMPONENTS FOR AUTOMATIC HANDLING)

NOTE5. THE DIMENSIONS IN PARENTHESES ARE FOR REFERENCE.

HRS

DRAWING NO.	EDC3-355712-00
PART NO.	DF57H-*P-1.2V(23)
CODE NO.	CL666-

3/4

DF57 Series Mating / Unmating Operation Instruction

Mating

① By positioning the convexity of the socket sides to the header concavity, align the centers of the socket and the header in pitch direction.

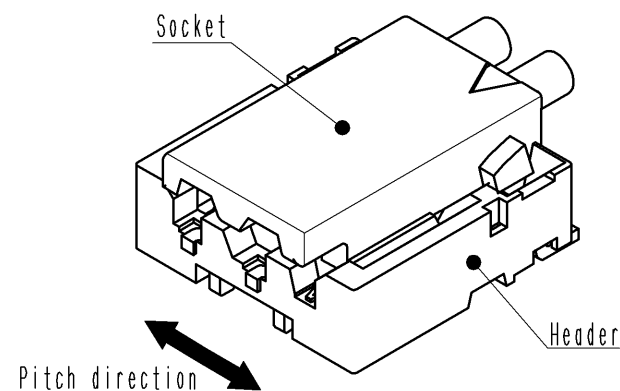

② Slightly press the socket down at cable side to tilted angle.

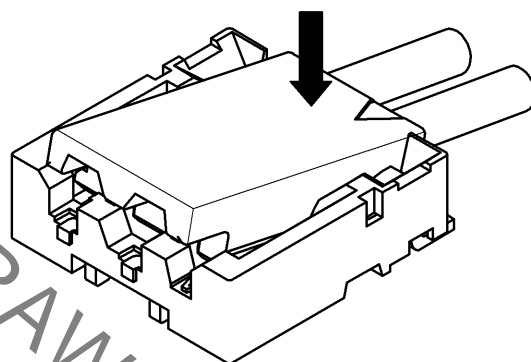

③ Press down at the lever side with stabilizing the cable side to insert. Mating completes.

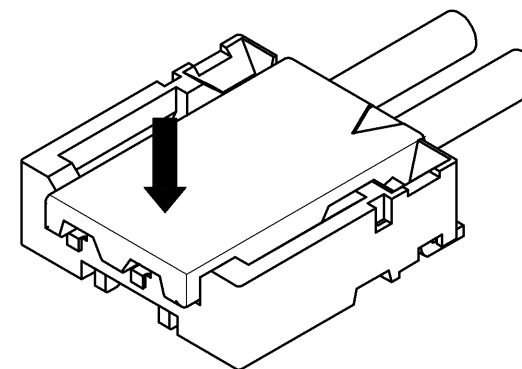

Unmating

① Hook the lever with finger nail.

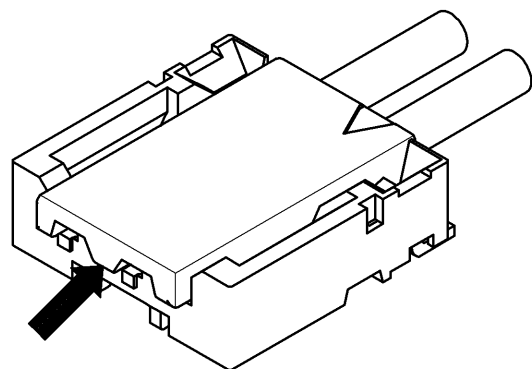

② Lift up to the upper direction and friction lock is released.

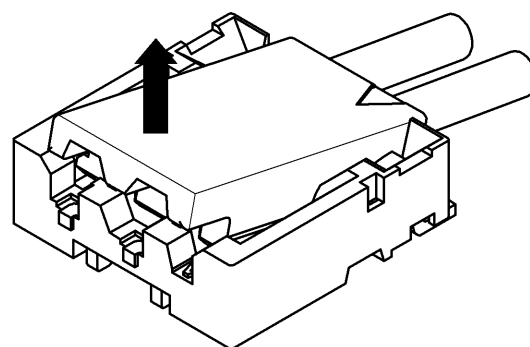

③ Lift up to the upper direction and positive lock is released. Removal completes.

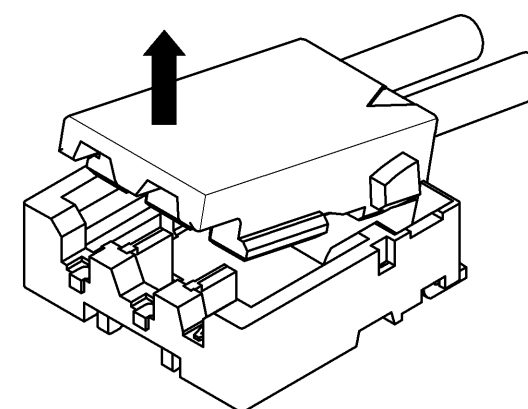

HRS DRAWING FOR REFERENCE

HRS	DRAWING NO.	EDC3-355712-00
	PART NO.	DF57H-*P-1.2V<23>
	CODE NO.	CL666-
		△ 4/4

Sep.1.2021 Copyright 2021 HIROSE ELECTRIC CO., LTD. All Rights Reserved. In case of consideration for using Automotive equipment / device which demand high reliability, kindly contact our sales window correspondents.

Mouser Electronics

Authorized Distributor

Click to View Pricing, Inventory, Delivery & Lifecycle Information:

[Hirose Electric:](#)

[DF57H-6P-1.2V\(23\)](#)