

Aug.1.2021 Copyright 2021 HIROSE ELECTRIC CO., LTD. All Rights Reserved.
In case of consideration for using Automotive equipment / device which demand high reliability, kindly contact our sales window correspondents.

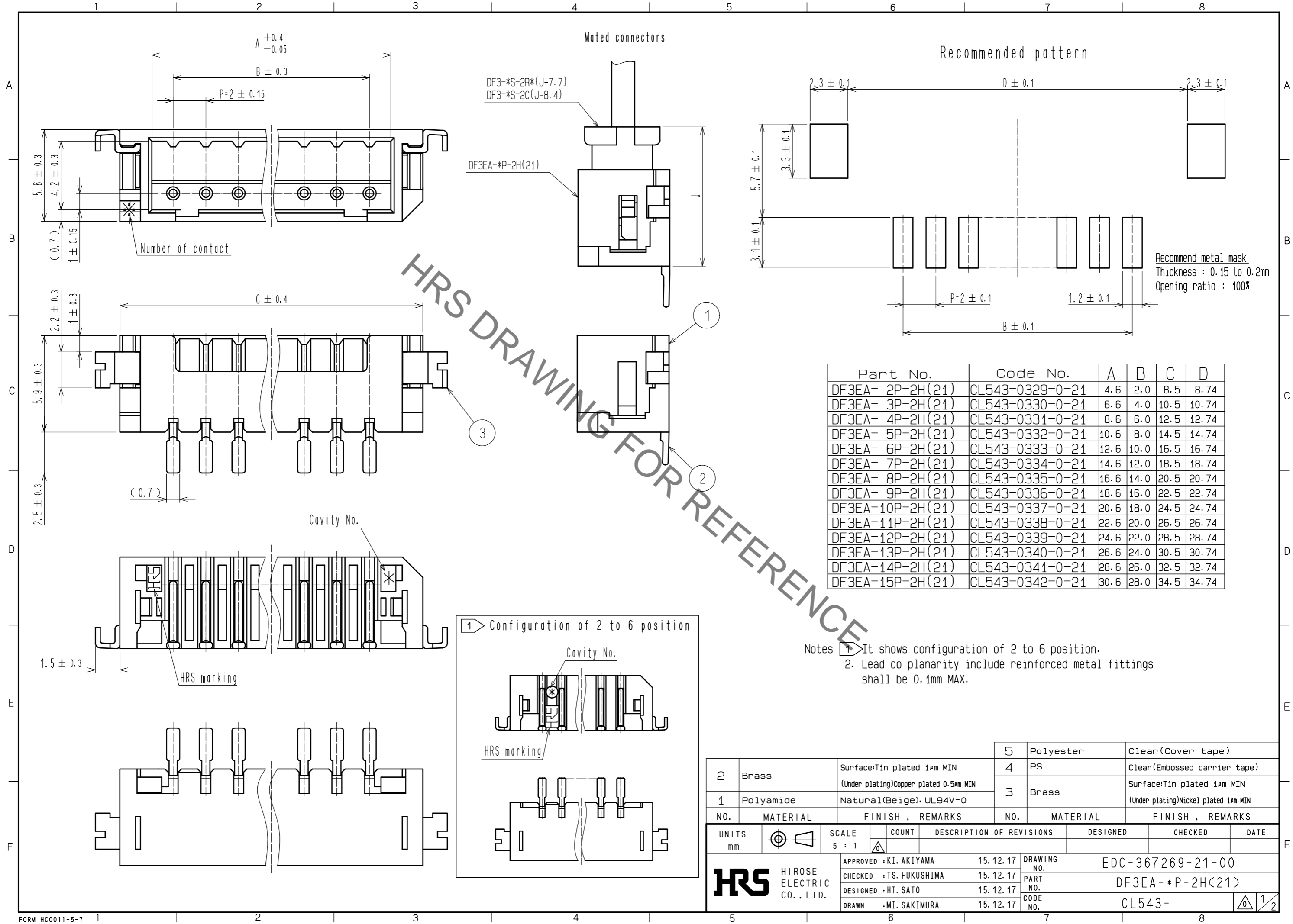

Part No.	Code No.	A	B	C	D
DF3EA- 2P-2H(21)	CL543-0329-0-21	4.6	2.0	8.5	8.74
DF3EA- 3P-2H(21)	CL543-0330-0-21	6.6	4.0	10.5	10.74
DF3EA- 4P-2H(21)	CL543-0331-0-21	8.6	6.0	12.5	12.74
DF3EA- 5P-2H(21)	CL543-0332-0-21	10.6	8.0	14.5	14.74
DF3EA- 6P-2H(21)	CL543-0333-0-21	12.6	10.0	16.5	16.74
DF3EA- 7P-2H(21)	CL543-0334-0-21	14.6	12.0	18.5	18.74
DF3EA- 8P-2H(21)	CL543-0335-0-21	16.6	14.0	20.5	20.74
DF3EA- 9P-2H(21)	CL543-0336-0-21	18.6	16.0	22.5	22.74
DF3EA-10P-2H(21)	CL543-0337-0-21	20.6	18.0	24.5	24.74
DF3EA-11P-2H(21)	CL543-0338-0-21	22.6	20.0	26.5	26.74
DF3EA-12P-2H(21)	CL543-0339-0-21	24.6	22.0	28.5	28.74
DF3EA-13P-2H(21)	CL543-0340-0-21	26.6	24.0	30.5	30.74
DF3EA-14P-2H(21)	CL543-0341-0-21	28.6	26.0	32.5	32.74
DF3EA-15P-2H(21)	CL543-0342-0-21	30.6	28.0	34.5	34.74

Notes
 1 It shows configuration of 2 to 6 position.
 2. Lead co-planarity include reinforced metal fittings shall be 0.1mm MAX.

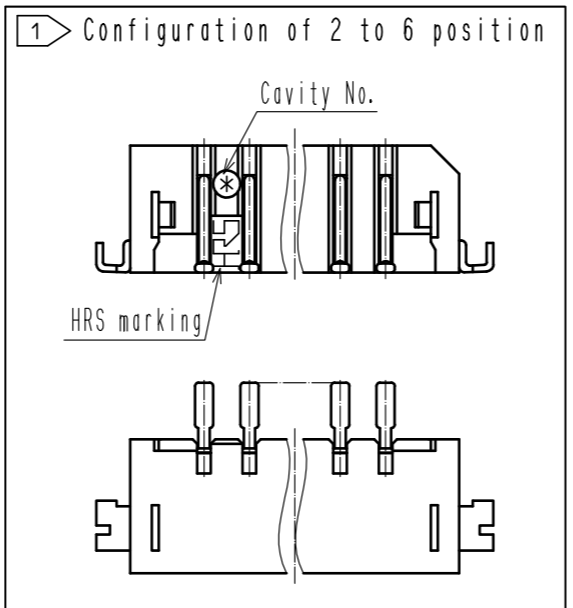

NO.	MATERIAL	FINISH .	REMARKS	NO.	MATERIAL	FINISH .	REMARKS
2	Brass	Surface: Tin plated 1μm MIN (Under plating) Copper plated 0.5μm MIN		5	Polyester		Clear(Cover tape)
1	Polyamide	Natural(Beige), UL94V-0		4	PS		Clear(Embossed carrier tape)
				3	Brass	Surface: Tin plated 1μm MIN (Under plating) Nickel plated 1μm MIN	

UNITS	SCALE	COUNT	DESCRIPTION OF REVISIONS	DESIGNED	CHECKED	DATE
mm	5 : 1	△				

APPROVED : KI. AKIYAMA	15.12.17	DRAWING NO.	EDC-367269-21-00
CHECKED : TS. FUKUSHIMA	15.12.17	PART NO.	DF3EA-*P-2H(21)
DESIGNED : HT. SATO	15.12.17	CODE NO.	CL543-
DRAWN : MI. SAKIMURA	15.12.17		

Aug.1.2021 Copyright 2021 HIROSE ELECTRIC CO., LTD. All Rights Reserved.
In case of consideration for using Automotive equipment / device which demand high reliability, kindly contact our sales window correspondents.

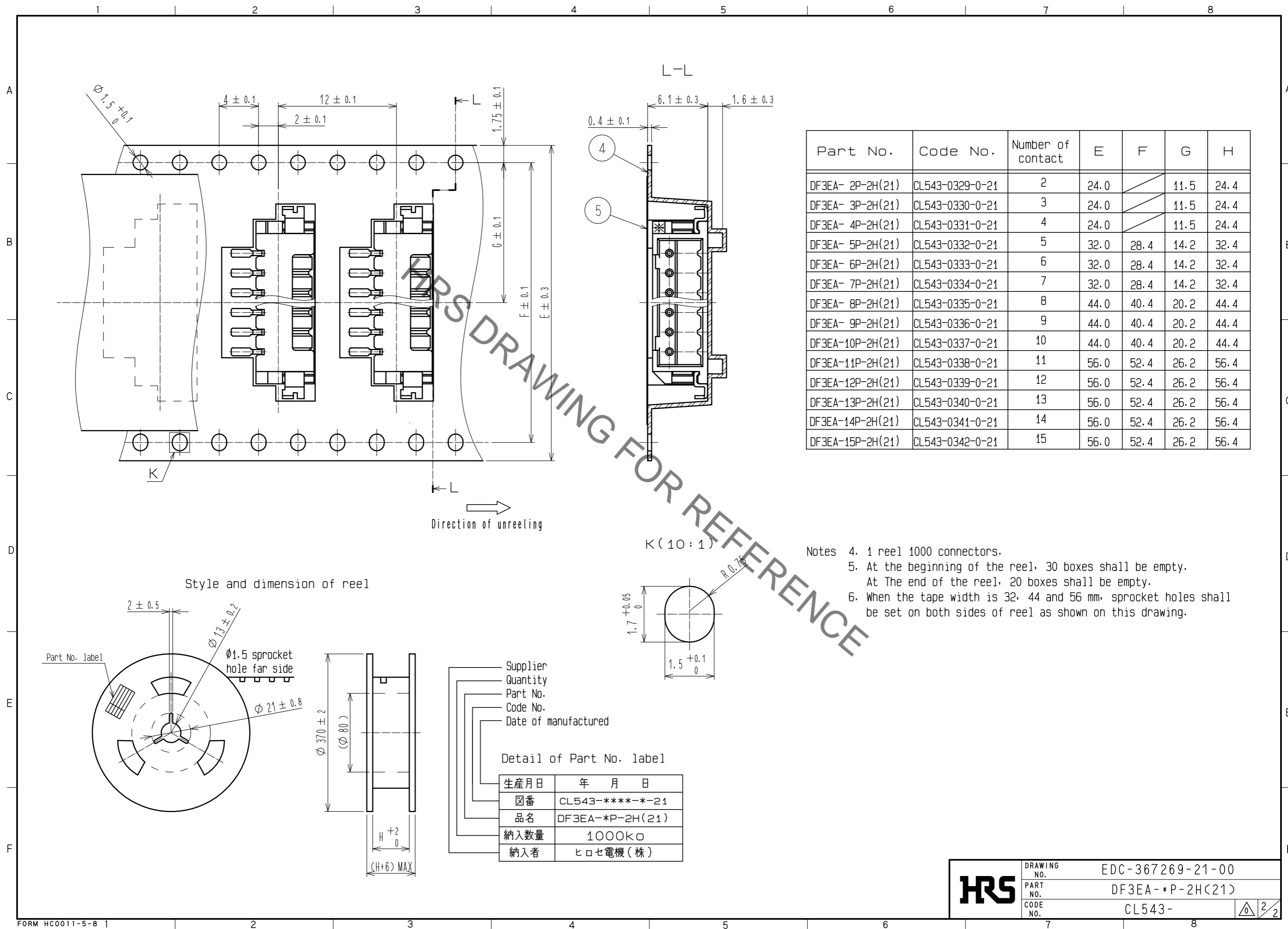

HRS	DRAWING NO.	EDC-367269-21-00
	PART NO.	DF3EA-*P-2H(21)
	CODE NO.	CL543-

Mouser Electronics

Authorized Distributor

Click to View Pricing, Inventory, Delivery & Lifecycle Information:

[Hirose Electric:](#)

[DF3EA-10P-2H\(21\)](#)