

Sep.1.2021 Copyright 2021 HIROSE ELECTRIC CO., LTD. All Rights Reserved.  
In case of consideration for using Automotive equipment / device which demand high reliability, kindly contact our sales window correspondents.

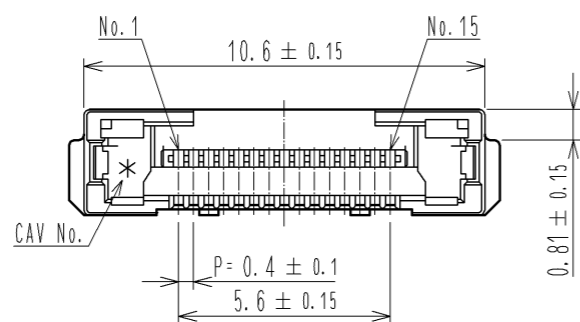

RECOMMENDED CABLE SUBASSEMBLY

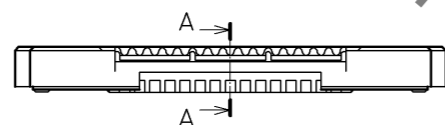
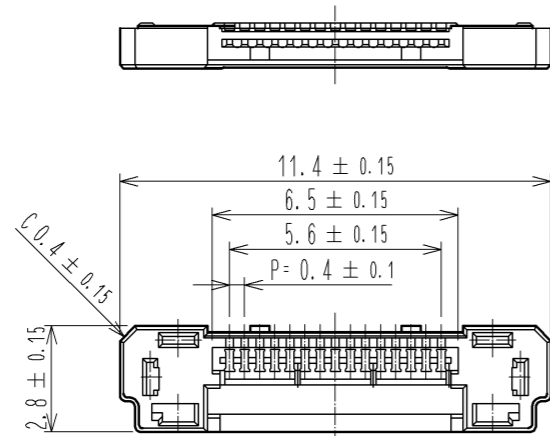
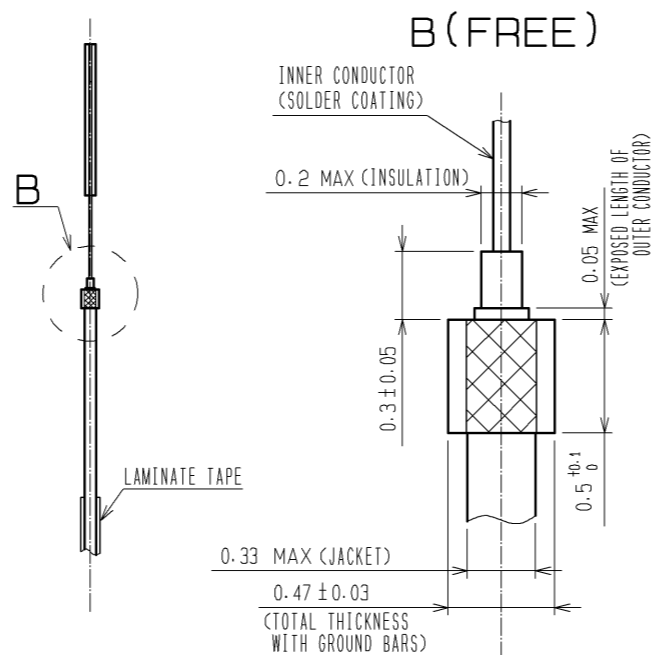
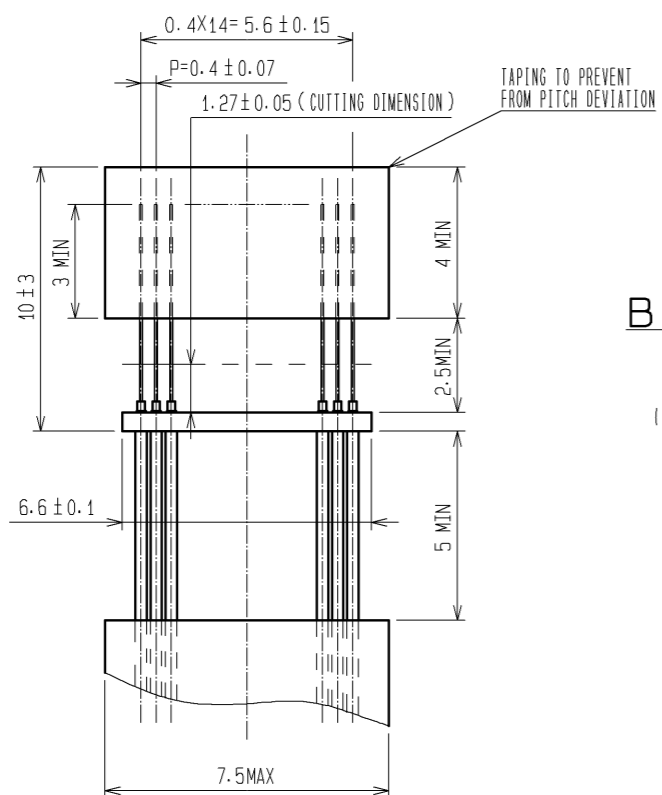

A-A (FREE)

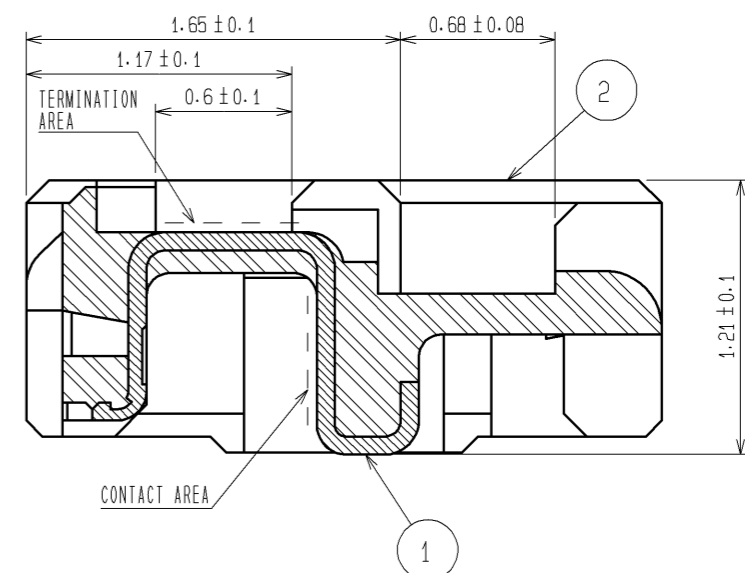

CABLE TERMINATION FIGURE (FREE)

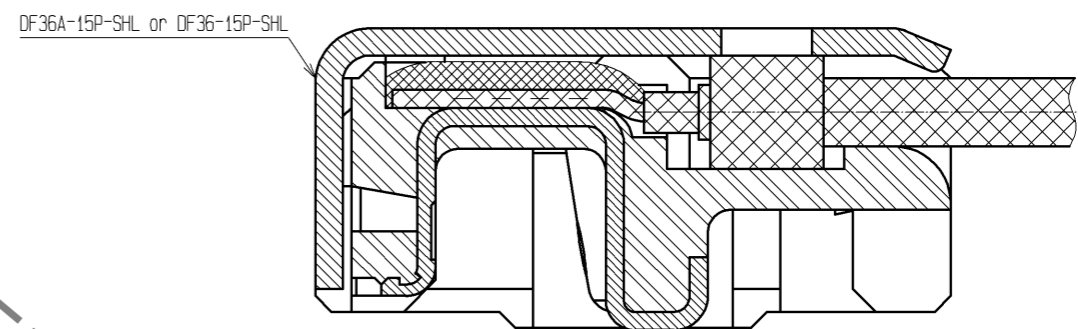

- NOTES 1. APPLICABLE CABLE: THIN COAXIAL CABLE (AWG#42-AWG#46)  
 2. THIS CONNECTOR IS NOT HOT PLUGGABLE. MATE AND UNMATE WHILE THE POWER IS OFF.  
 3. THE ASSEMBLY IS COMPLETED BY COMBINING TWO PARTS "CONNECTOR UNIT AND METAL SHIELDING". REFER TO THE TABLE FOR EACH ITEM No., PART NAME, PART No. AND CODE No. APPLICABLE SHELL IS DIFFERENT DEPENDING ON THE PART No. OF MATED CONNECTOR. USE DF36A-15P-SHL FOR DF36A-15S-0.4V(\*\*), USE DF36-15P-SHL FOR DF36-15S-0.4V(\*\*).

ITEM No.	PART NAME	PART No.	CODE No.
1, 2	CONNECTOR UNIT	DF36C-15P-0.4SD(51)	CL662-4035-2-51
-	METAL SHIELDING	DF36A-15P-SHL	CL662-4511-7-00
-	METAL SHIELDING	DF36-15P-SHL	CL662-4526-1-00

4. BLACK MARKS MAY OCCASIONALLY OCCUR IN MOLD RESIN, YET THEY NOT AFFECT CONNECTOR QUALITY.

NO.	MATERIAL	FINISH	REMARKS	NO.	MATERIAL	FINISH	REMARKS
2	LCP		UL94V-0, BEIGE	2	PS		BLACK
1	PHOSPHOR BRONZE	CONTACT AREA	Au PLATING 0.1µm min	4	POLYESTER		CLEAR
		TERMINATION AREA	Au PLATING 0.1µm min	3	PS		CLEAR
UNDER PLATING	Ni PLATING 1µm min						

  

UNITS	SCALE	COUNT	DESCRIPTION OF REVISIONS	DESIGNED	CHECKED	DATE
mm	5 : 1	△				

  

APPROVED : TS. SAKATA	11.11.08	DRAWING NO.	EDC3-320250-01
CHECKED : HS. OZAWA	11.11.08	PART NO.	DF36C-15P-0.4SD(51)
DESIGNED : TP. MATSUMOTO	11.11.07	CODE NO.	CL662-4035-2-51
DRAWN : TP. MATSUMOTO	11.11.07		

Sep.1.2021 Copyright 2021 HIROSE ELECTRIC CO., LTD. All Rights Reserved.  
 In case of consideration for using Automotive equipment / device which demand high reliability, kindly contact our sales window correspondents.

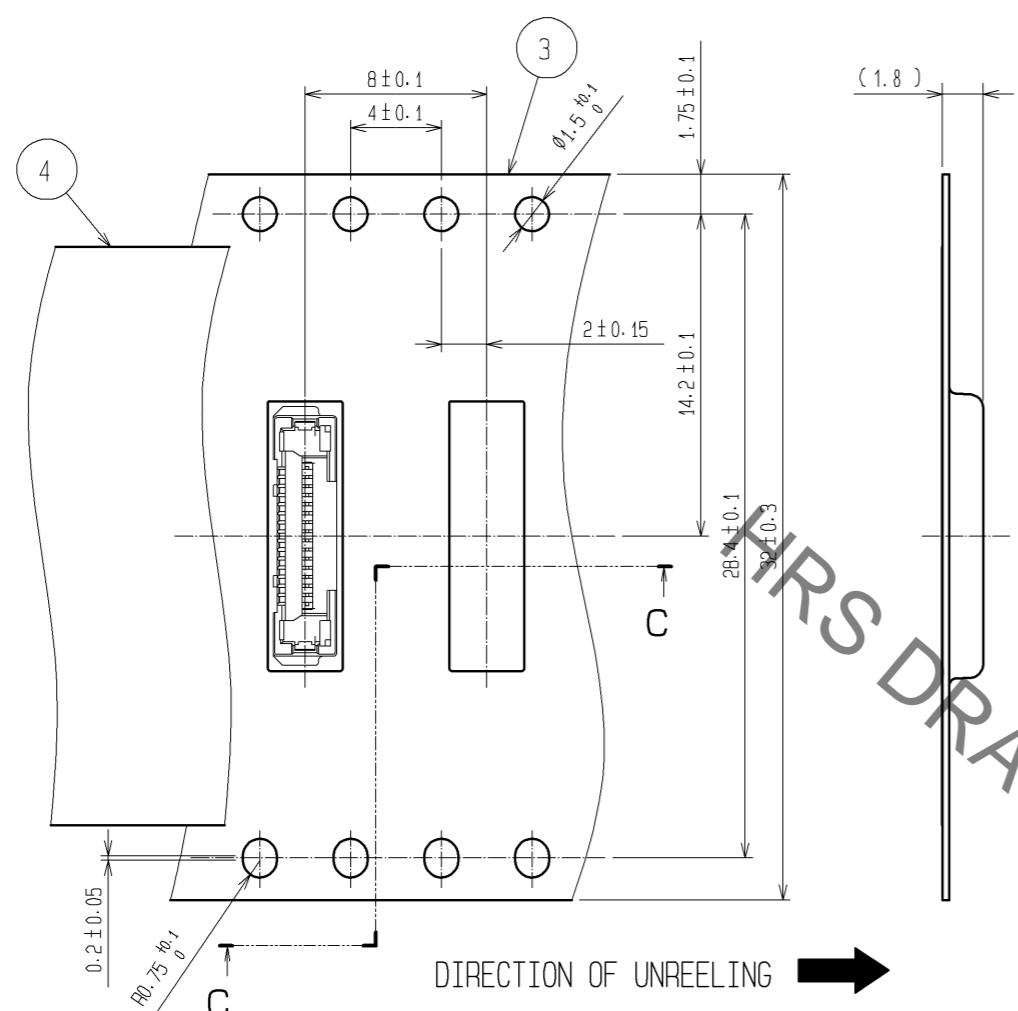

STYLE AND DIMENSION OF REEL (FREE)

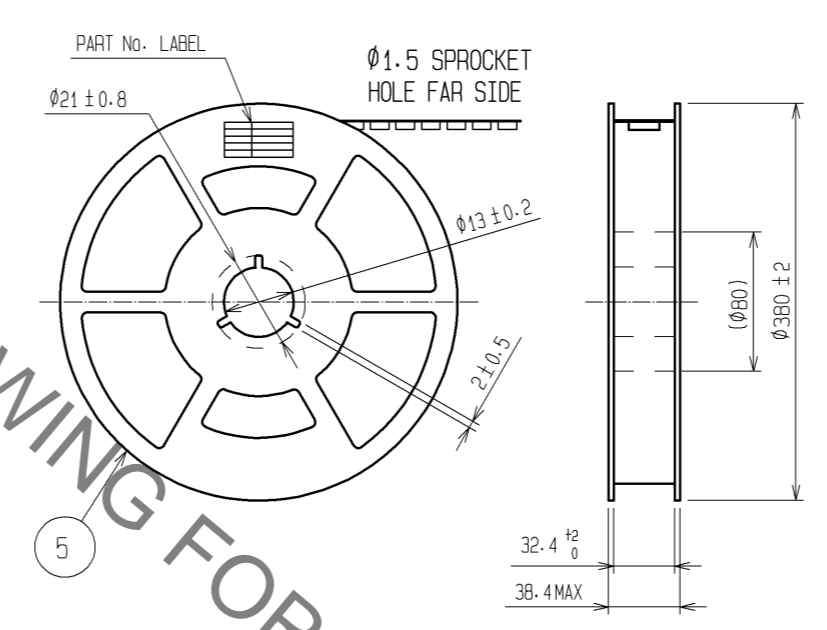

DETAIL OF PART No. LABEL

生産月日	年 月 日
製品コード	CL662-4035-2-51
製品名	DF36C-15P-0.4SD(51)
納入数量	5,000pcs
納入者	ヒロセ電機(株)

\_\_\_\_\_ SUPPLIER  
 \_\_\_\_\_ QUANTITY  
 \_\_\_\_\_ PART No.  
 \_\_\_\_\_ CODE No.  
 \_\_\_\_\_ DATE OF MANUFACTURED

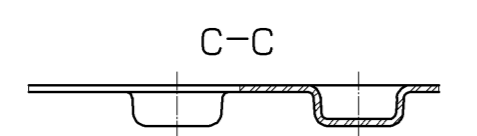

6 TAPING (FREE)

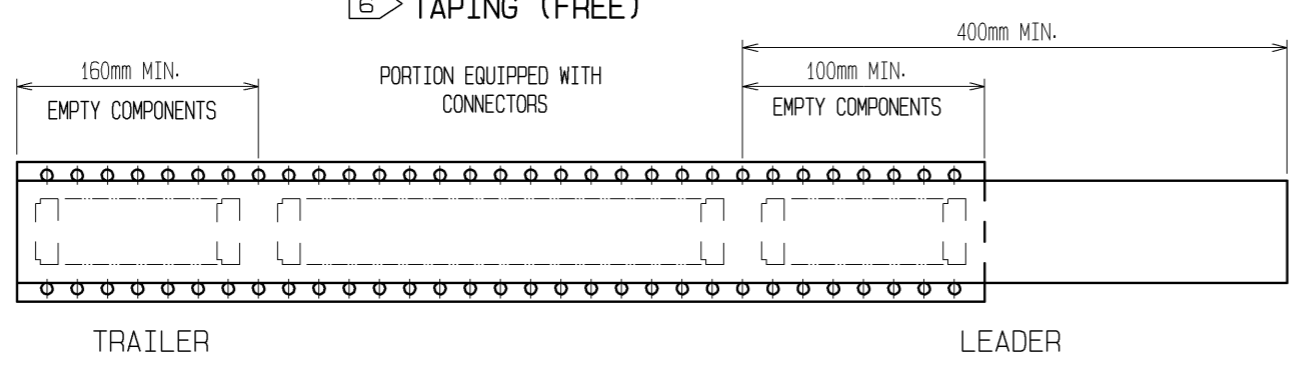

NOTES 5. PER REEL: 5000 COMPONENTS.  
 6 REFER TO JIS C 0806. (PACKAGING OF COMPONENTS FOR AUTOMATIC HANDLING)  
 7. THE DIMENSIONS IN PARENTHESES ARE FOR REFERENCE.

HRS DRAWING FOR REFERENCE

HRS	DRAWING NO.	EDC3-320250-01
	PART NO.	DF36C-15P-0.4SD(51)
	CODE NO.	CL662-4035-2-51
		△ 2/2

# Mouser Electronics

Authorized Distributor

Click to View Pricing, Inventory, Delivery & Lifecycle Information:

[Hirose Electric:](#)

[DF36C-15P-0.4SD\(51\)](#)