

| NO. | DESCRIPTION OF REVISIONS | BY | CHKD | DATE | COUNT | DESCRIPTION OF REVISIONS | BY | CHKD | DATE |
|-----|--------------------------|----|------|------|-------|--------------------------|----|------|------|
| | | | | | | | | | |
| | | | | | | | | | |
| | | | | | | | | | |

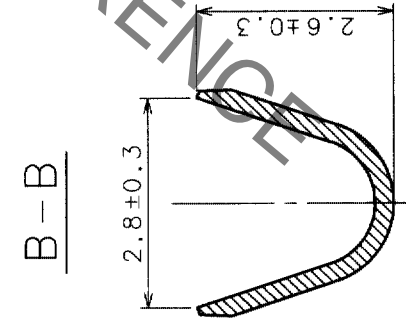
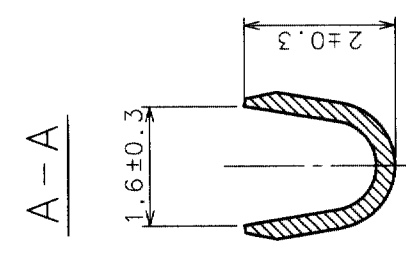
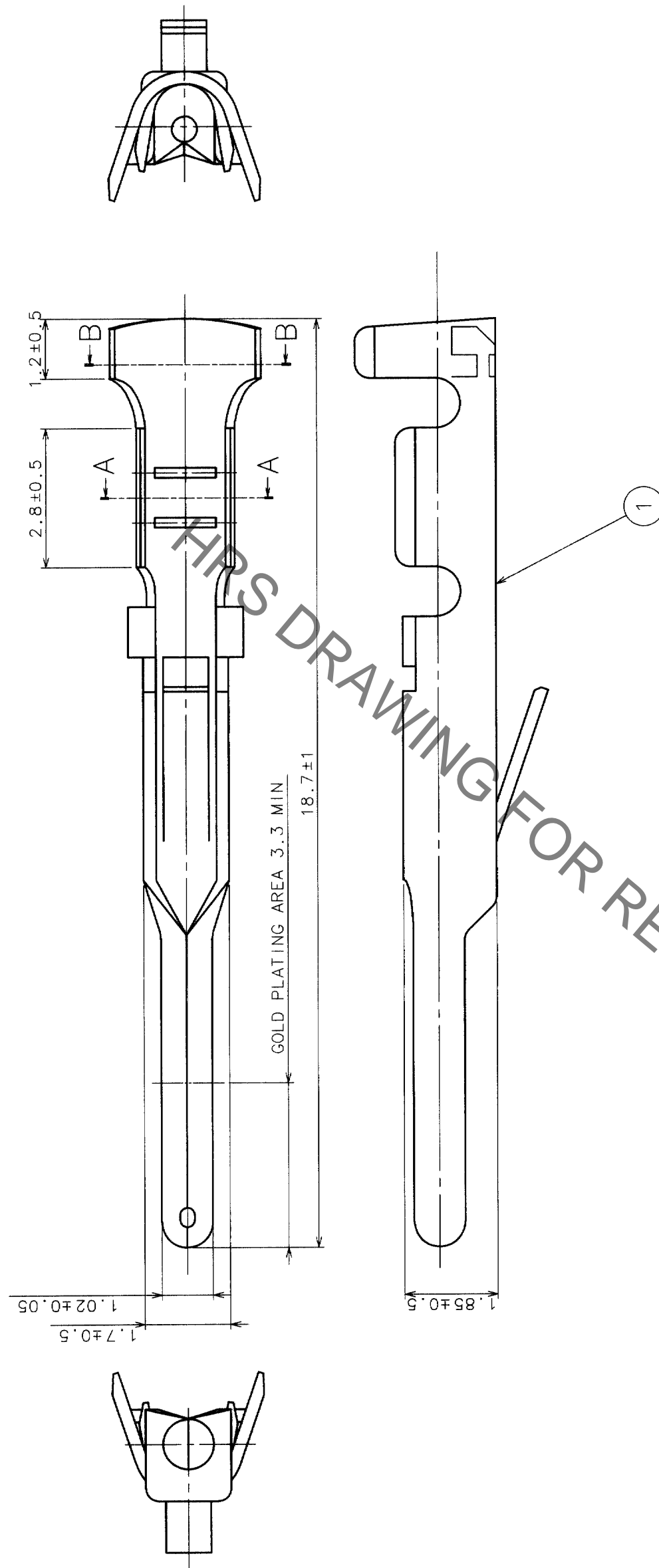

| | |
|----|--|
| TO | |
| Q1 | |
| | |
| | |

| NO. | MATERIAL | FINISH, REMARKS | FINISH, REMARKS | NO. | MATERIAL | FINISH, REMARKS |
|-----|-----------------|---|-----------------|-----|----------|-----------------|
| 1 | PHOSPHOR BRONZE | CONTACT AREA: GOLD 0.2μm min UNDER PLATING: NICKEL 1μm min | | | | |

| | | | |
|----------------|--------|-------------|--------------|
| CODE NO. (OLD) | | CODE NO. | CL211-0185-8 |
| SCALE | 10 : 1 | PART NO. | CD-PC-111 |
| UNITS | MM | DRAWING NO. | EDC3-009096 |
| | | | |

| | | | | | | | |
|-------|-------------|---------|-------------|----------|-------------|----------|--|
| DRAWN | M. Shingema | CHECKED | M. Shingema | APPROVED | M. Shingema | RELEASED | |
| | 03.3.31 | | 03.3.31 | | 03.3.31 | | |

Mouser Electronics

Authorized Distributor

Click to View Pricing, Inventory, Delivery & Lifecycle Information:

[Hirose Electric:](#)

[CD-PC-111](#)