

Aug.1.2021 Copyright 2021 HIROSE ELECTRIC CO., LTD. All Rights Reserved.  
In case of consideration for using Automotive equipment / device which demand high reliability, kindly contact our sales window correspondents.

DRAWING FOR REFERENCE  
This is subject to change without notice

COUNT	DESCRIPTION OF REVISIONS	B	Y	CHKD	DATE	COUNT	DESCRIPTION OF REVISIONS	B	Y	CHKD	DATE
2	RE-6-0742			LYJ	JHW	16.09.27					
3	RE-6-0806			MSH	JHW	17.01.05					

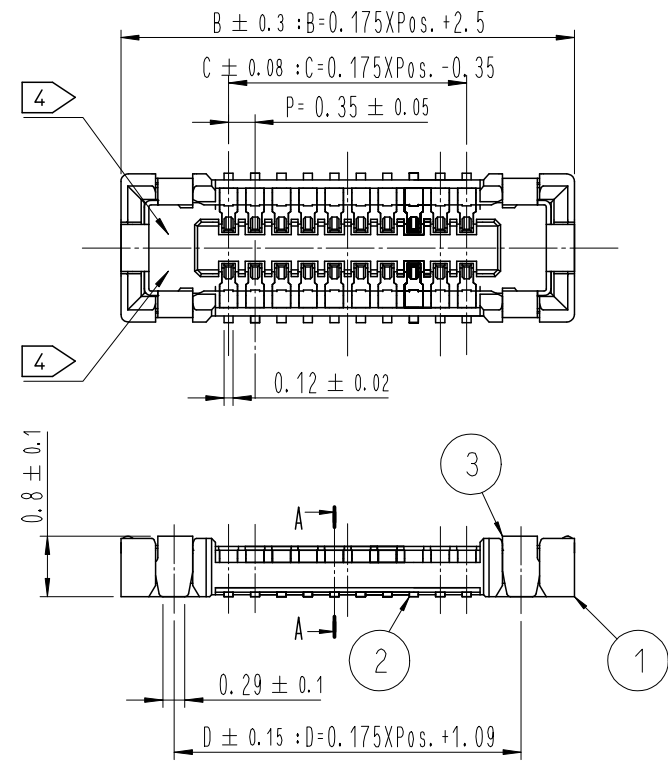

A-A(50:1)

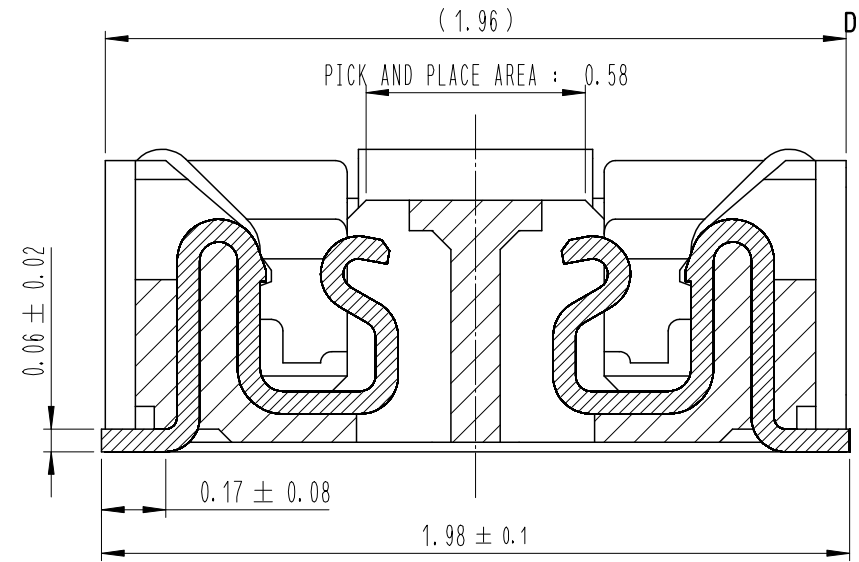

ENGAGEMENT FIGURE (50:1)

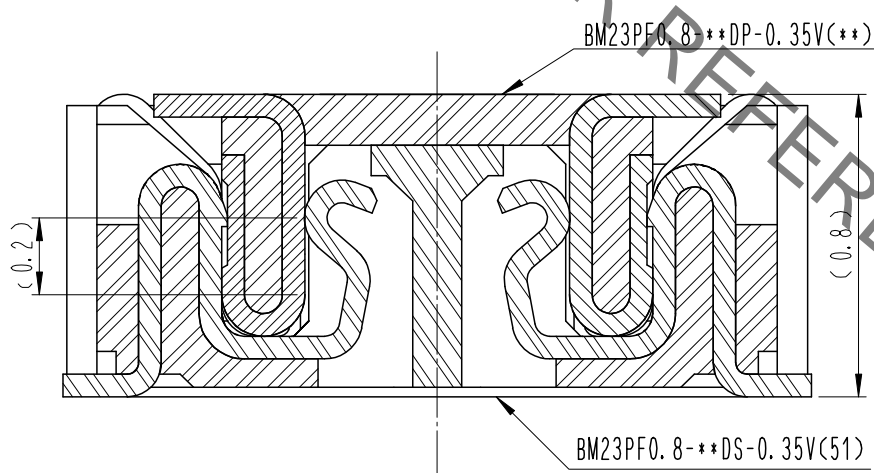

PART No.	CODE No.	POS.	B	C	D
BM23PF0.8-10DS-0.35V(51)	-	10	4.25	1.40	2.84
BM23PF0.8-14DS-0.35V(51)	-	14	4.95	2.10	3.54
BM23PF0.8-20DS-0.35V(51)	-	20	6.00	3.15	4.59
BM23PF0.8-24DS-0.35V(51)	-	24	6.70	3.85	5.29
BM23PF0.8-40DS-0.35V(51)	-	40	9.50	6.65	8.09
BM23PF0.8-42DS-0.35V(51)	-	42	9.85	7.00	8.44
BM23PF0.8-46DS-0.35V(51)	-	46	10.55	7.70	9.14
BM23PF0.8-54DS-0.35V(51)	-	54	11.95	9.10	10.54

- NOTE
- 1. ALL LEAD CO-PLANARITY SHALL BE 0.08mm MAX.
  - 2. CONTACT PLATING SPECIFICATIONS.  
CONTACT AREA : GOLD 0.05 μm MIN.  
SMT LEAD : GOLD 0.05 μm MIN.  
UNDERPLATING : NICKEL 1 μm MIN.  
( SURFACE : SEALING )
  - 3. METAL FITTING PLATING SPECIFICATIONS.  
SMT LEAD : GOLD 0.05 μm MIN.  
UNDERPLATING : NICKEL 1 μm MIN.  
( SURFACE : SEALING )
  - 4. HRS MARK AND CAV NO. IS INDICATED IN APPROX POSITION SHOWN.

4	PS	CLEAR (EMBOSSED CARRIER TAPE)			
3	COOPER ALLOY	3	7	PS	CLEAR (REINFORCEMENT COLLAR)
2	COOPER ALLOY	2	6	PS	BLACK (PLASTIC REEL)
1	LCP	UL94 V-0, BLACK	5	POLYESTER	CLEAR (COVER TAPE)
NO.	MATERIAL	FINISH, REMARKS	NO.	MATERIAL	FINISH, REMARKS
REMARKS			DRAWN	DESIGNED	CHECKED
			Y. J. LEE	Y. J. LEE	H. W. JO
			15.11.23	15.11.23	15.11.23
			APPROVED	RELEASED	
			T. S. KANG	15.11.23	15.11.23
CODE NO. (OLD)	DRAWING NO.	PART NO.		CODE NO.	
	EDC3-*****	BM23PF0.8-**-DS-0.35V(51)		CL 66**-*****-***	
SCALE	UNITS	HRS HIROSE KOREA CO., LTD.		1/3	
10:1	mm				

Aug.1.2021 Copyright 2021 HIROSE ELECTRIC CO., LTD. All Rights Reserved.  
In case of consideration for using Automotive equipment / device which demand high reliability, kindly contact our sales window correspondents.

6 RECOMMENDED PCB LAYOUT

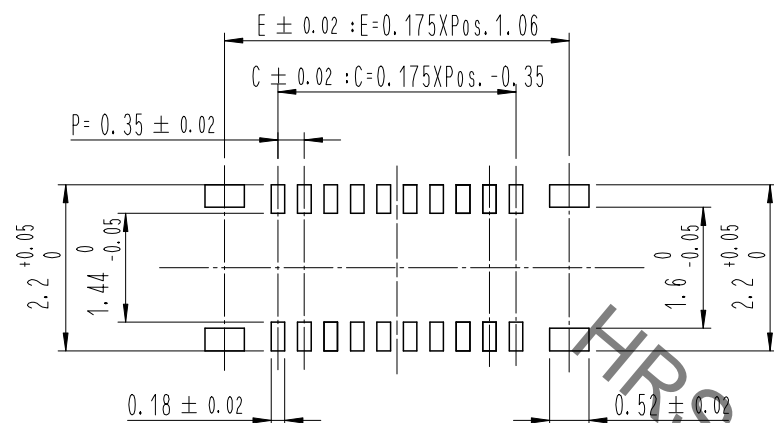

POS.	C	E
10	1.40	2.81
14	2.10	3.51
20	3.15	4.56
24	3.85	5.26
40	6.65	8.06
42	7.00	8.41
46	7.70	9.11
54	9.10	10.51

RECOMMENDED METAL MASK DIMENSIONS  
MATAL MASK THICKNESS : 100 μm

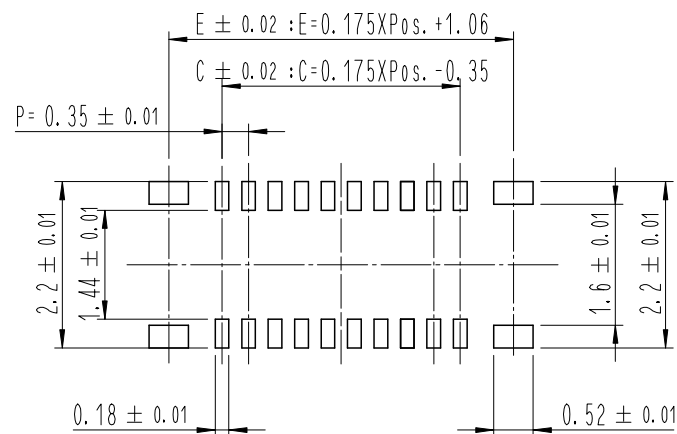

5 RECOMMENDED REFLOW TEMPERATURE PROFILE USING LEAD-FREE SOLDER PASTE.

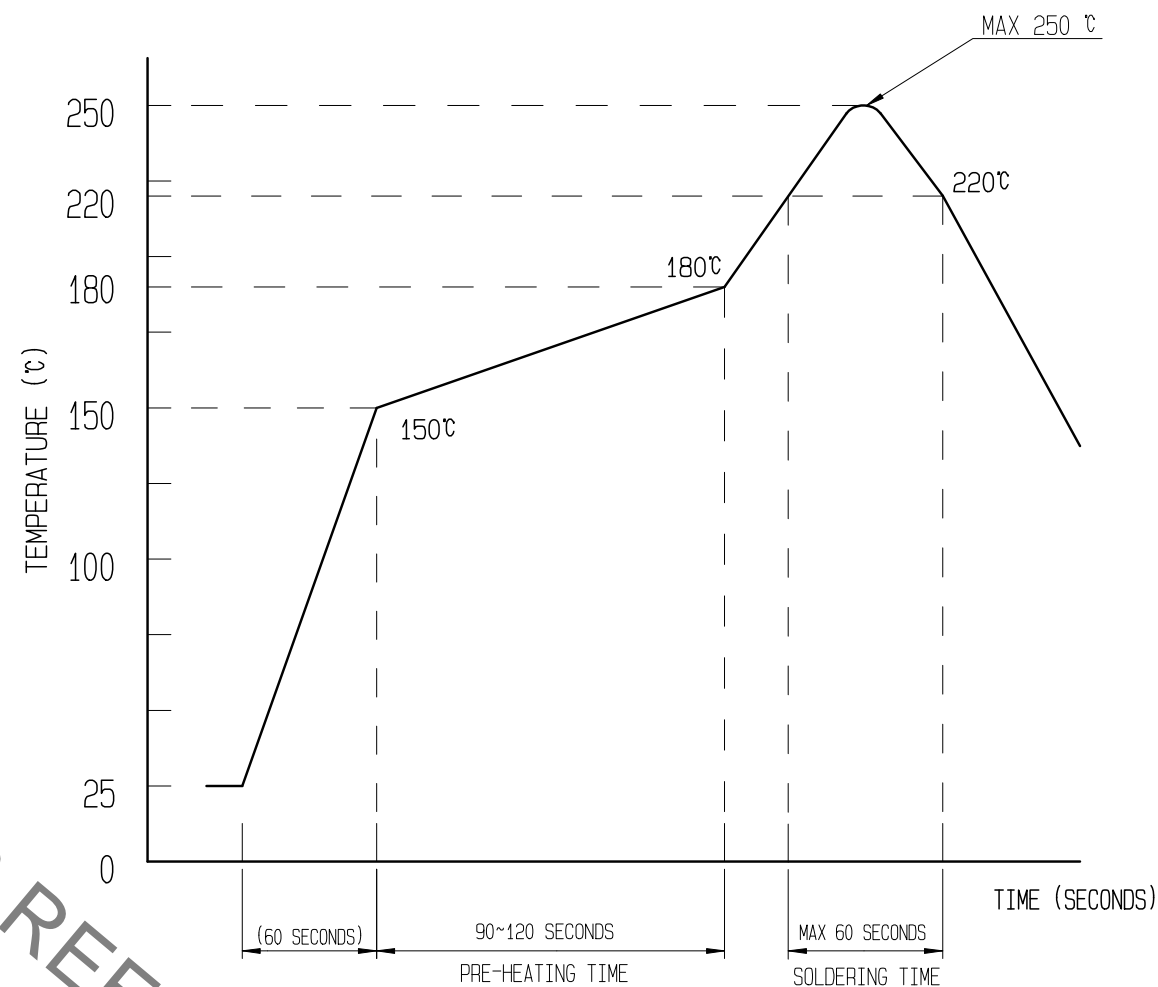

REFLOW METHOD: IR REFLOW  
NUMBER OF REFLOW CYCLES: 2 CYCLES MAX.  
1) REFLOW TIME  
DURATION ABOVE 220°C, 60 SEC MAX.  
(PEAK TEMPERATURE: 250°C MAX)  
2) PRE-HEAT TIME  
PRE-HEAT TEMPERATURE(MIN): 150°C  
PRE-HEAT TEMPERATURE(MAX): 180°C  
PRE-HEAT TIME: 90-120 SEC.

- 5 THIS TEMPERATURE PROFILE IS PER THE CONDITIONS SHOWN ABOVE. ADDITIONAL FACTORS, SUCH AS SOLDER PASTE TYPE, PCB SIZE AND OTHER MOUNTED COMPONENTS COULD AFFECT THE PROFILE. THEREFORE, A THOROUGH EVALUATION OF MOUNTING CONDITION IS REQUIRED PRIOR TO PRODUCTION. TEMPERATURE IS MEASURED AT CONTACT LEAD.
- 6 PLEASE CONTACT US IN CASE YOU WILL MAKE DIFFERENT SETTINGS FROM OUR RECOMMENDATION.

 SCALE 10:1 UNITS mm	DRAWING NO.	EDC3-*****	PART NO.	BM23PF0.8-**DS-0.35V(51)
	HIROSE KOREA CO., LTD.		CODE NO.	CL 66**-*****-***
				2/3

Aug.1.2021 Copyright 2021 HIROSE ELECTRIC CO., LTD. All Rights Reserved.  
 In case of consideration for using Automotive equipment / device which demand high reliability, kindly contact our sales window correspondents.

# EMBOSSED CARRIER TAPE PACKAGING (5:1)

△ POS.	F	G	H	J	K
10	16	7.5	4.36	17.5	21.5
14	16	7.5	5.06	17.5	21.5
20	16	7.5	6.11	17.5	21.5
24	16	7.5	6.81	17.5	21.5
40	24	11.5	9.61	25.5	29.5
42	24	11.5	9.96	25.5	29.5
46	24	11.5	10.66	25.5	29.5
54	24	11.5	12.06	25.5	29.5

L-L (5:1)

N (10:1)

M-M (5:1)

DIRECTION OF UNREELING →

STYLE AND DIMENTION OF REEL (FREE)

## DETAIL OF PART No. LABEL

—	SUPPLIER
—	QUANTITY
—	PART NO.
—	CODE NO.
—	DATE OF MANUFACTURED
生産月日	年 月 日
図番	** ** *
品名	BM23PF0.8-**-DS-0.35V(51)
納入数量	10,000個
納入者	HIROSE KOREA

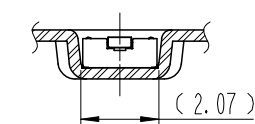

Q-Q (FREE)

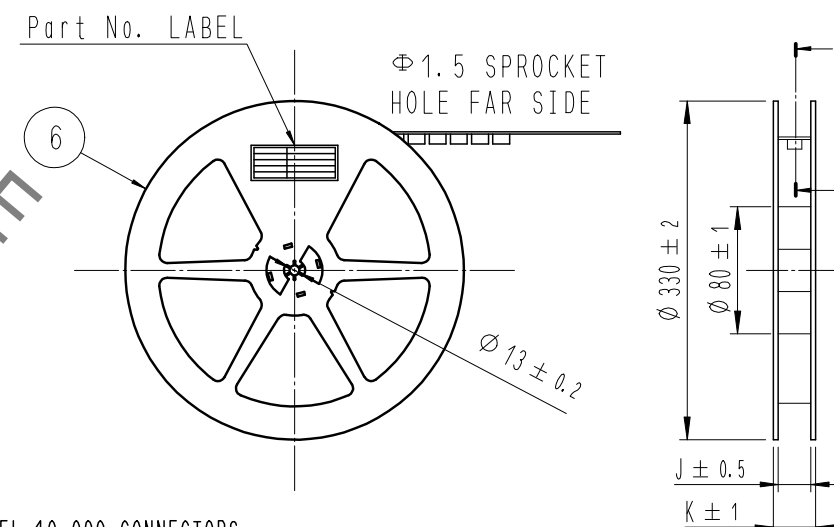
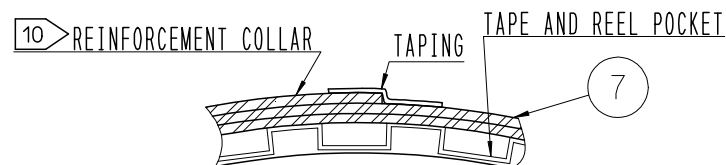

9 TAPING(FREE)

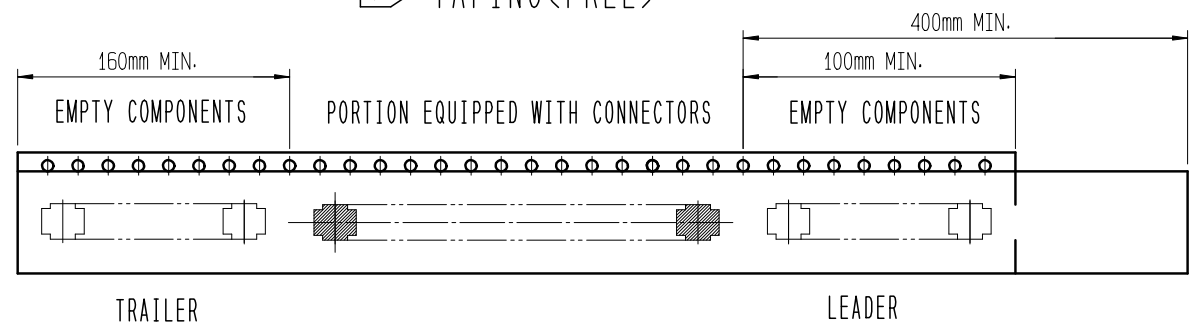

7 . PER REEL 10,000 CONNECTORS.

8 . THE DIMENSIONS IN PARENTHESES ARE FOR REFERENCE.

9 REFER TO JIS C 0806, IEC-60286-3 (PACKAGING OF COMPONENTS FOR AUTOMATIC HANDLING)

10 AFTER PACKAGING. ROLL 2 METERS OF THE REINFORCEMENT COLLAR TO OUTER CIRCUMFERENCE OF TAPE AND REEL POCKET. AND TAPE DOWN AT THE END THE COLLAR.

 SCALE 10:1 UNITS mm	DRAWING NO. EDC3-*****	PART NO. BM23PF0.8-**-DS-0.35V(51)
	<b>HRS</b> HIROSE KOREA CO., LTD.	
	CODE NO. CL 66**-*****-***	3/3

# Mouser Electronics

Authorized Distributor

Click to View Pricing, Inventory, Delivery & Lifecycle Information:

[Hirose Electric:](#)

[BM23PF0.8-10DS-0.35V\(51\)](#)