

Sep.1.2021 Copyright 2021 HIROSE ELECTRIC CO., LTD. All Rights Reserved.
In case of consideration for using Automotive equipment / device which demand high reliability, kindly contact our sales window correspondents.

COUNT	DESCRIPTION OF REVISIONS	B	Y	CHKD	DATE	COUNT	DESCRIPTION OF REVISIONS	B	Y	CHKD	DATE
4	RE-6-1800	YDK	JHW		20. 04. 17						
2	RE-6-1973	JHK	JHW		20. 08. 25						

ENGAGEMENT FIGURE (50:1)

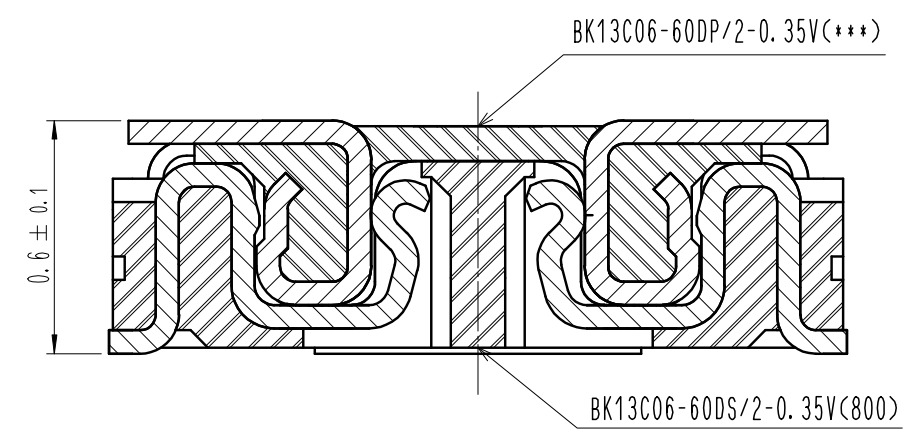

SIGNAL CONTACT

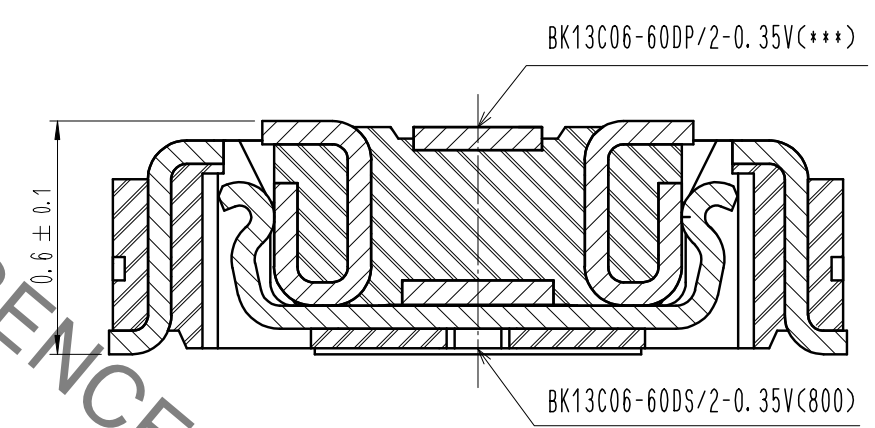

POWER CONTACT

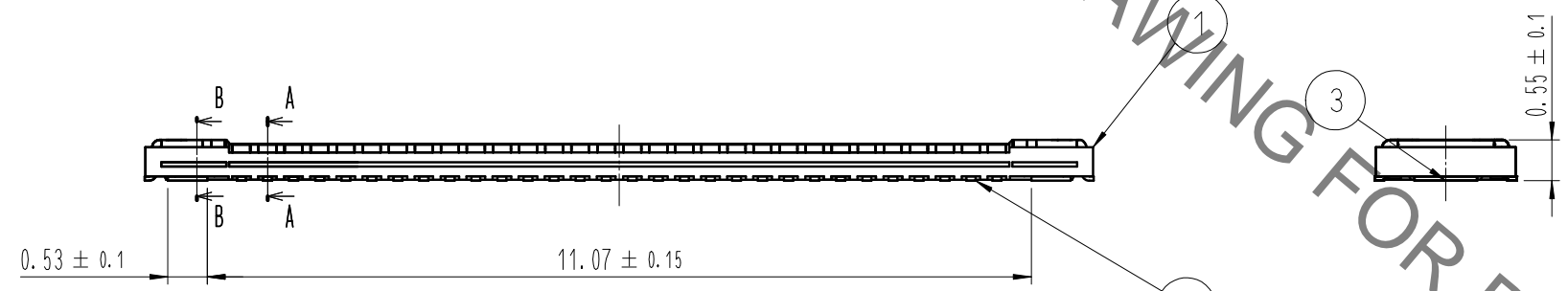
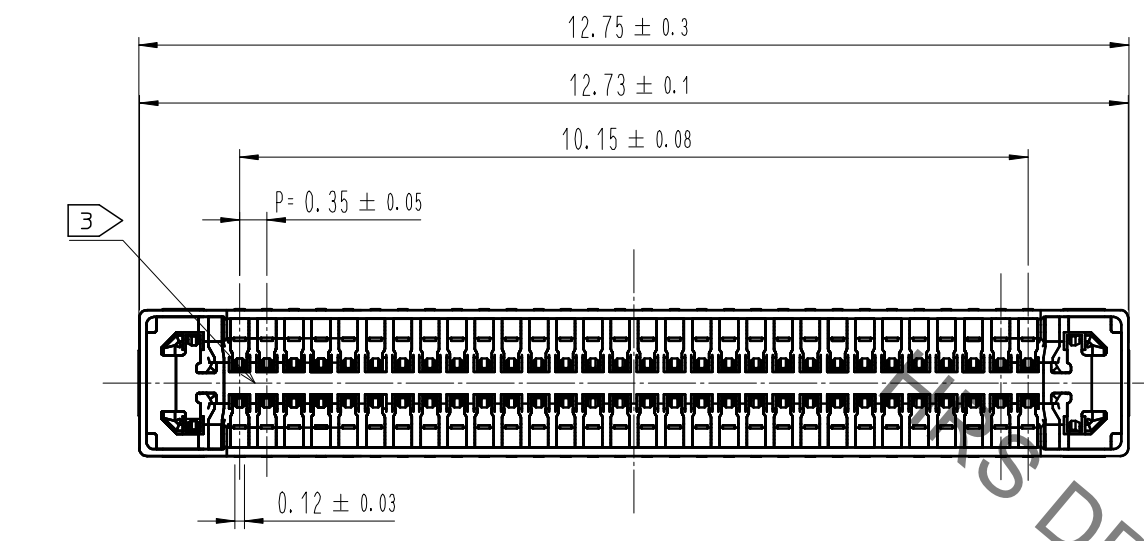

A-A (30:1)

B-B (30:1)

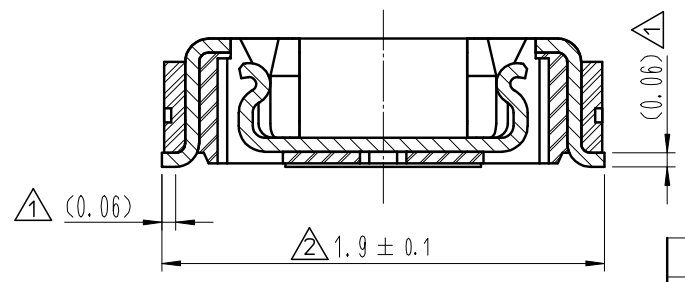
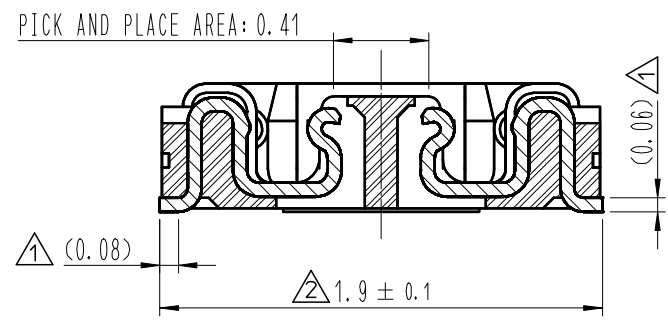

- NOTE
- 1. ALL LEAD CO-PLANARITY SHALL BE 0.08mm MAX.
 - 2. CONTACT PLATING SPECIFICATIONS
 CONTACT AREA : GOLD 0.05 μm MIN
 SMT LEAD : GOLD 0.05 μm MIN
 UNDERPLATING : NICKEL 1 μm MIN
 (SURFACE : SEALING)
 - 3. CAV NO. ARE INDICATED IN APPROX POSITION SHOWN.

4	PS	CLEAR (EMBOSSED CARRIER TAPE)			
3	COPPER ALLOY	2			
2	COPPER ALLOY	2			
1	LCP	UL94 V-0, BLACK	6	PS	BLACK (PLASTIC REEL)
			5	POLYESTER	CLEAR (COVER TAPE)
NO.	MATERIAL	FINISH, REMARKS	NO.	MATERIAL	FINISH, REMARKS
REMARKS			DRAWN	DESIGNED	CHECKED
			H. K. JEON	H. K. JEON	H. W. JO
			20. 02. 18	20. 02. 18	20. 02. 18
			APPROVED	RELEASED	
			H. W. JO		20. 02. 18
CODE NO. (OLD)	DRAWING NO. EDC3-632999-80		PART NO. BK13C06-60DS/2-0.35V(800)		
SCALE 10:1	UNITS mm		CODE NO. CL 6665-0030-6-800		1/3
		HRS HIROSE KOREA CO., LTD.			

Sep.1.2021 Copyright 2021 HIROSE ELECTRIC CO., LTD. All Rights Reserved.
In case of consideration for using Automotive equipment / device which demand high reliability, kindly contact our sales window correspondents.

5 RECOMMENDED PCB LAYOUT

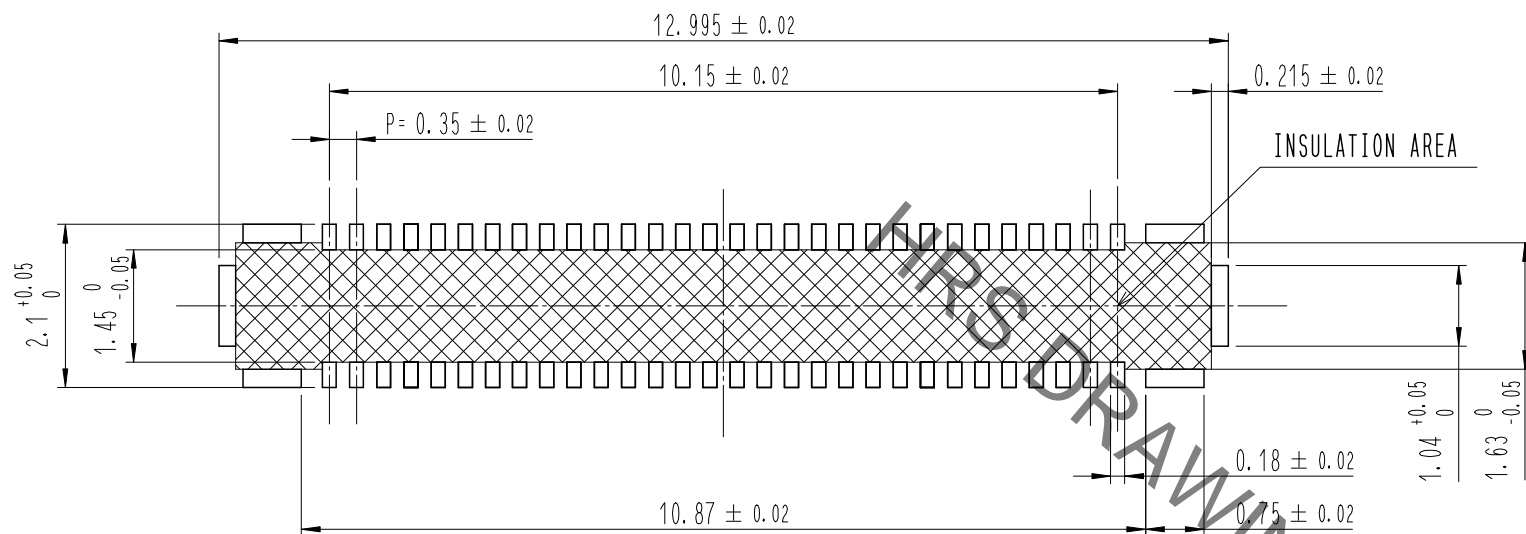

RECOMMENDED METAL MASK DIMENSIONS

METAL MASK THICKNESS : 80 μm

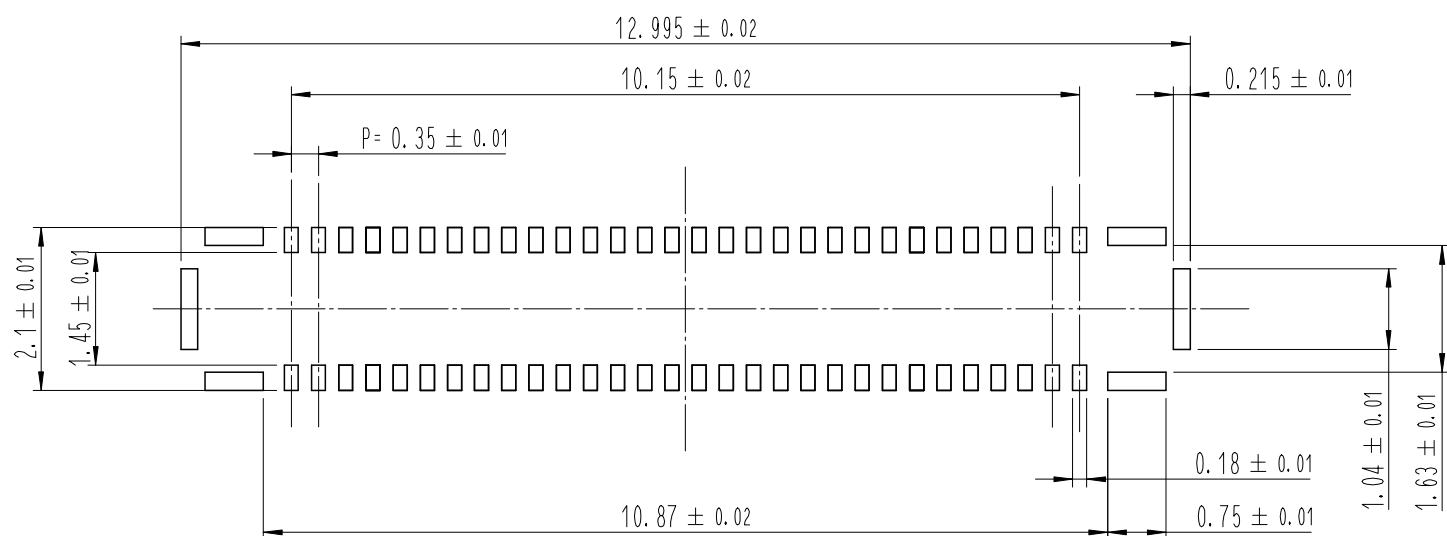

4 RECOMMENDED REFLOW TEMPERATURE PROFILE USING LEAD-FREE SOLDER PASTE.

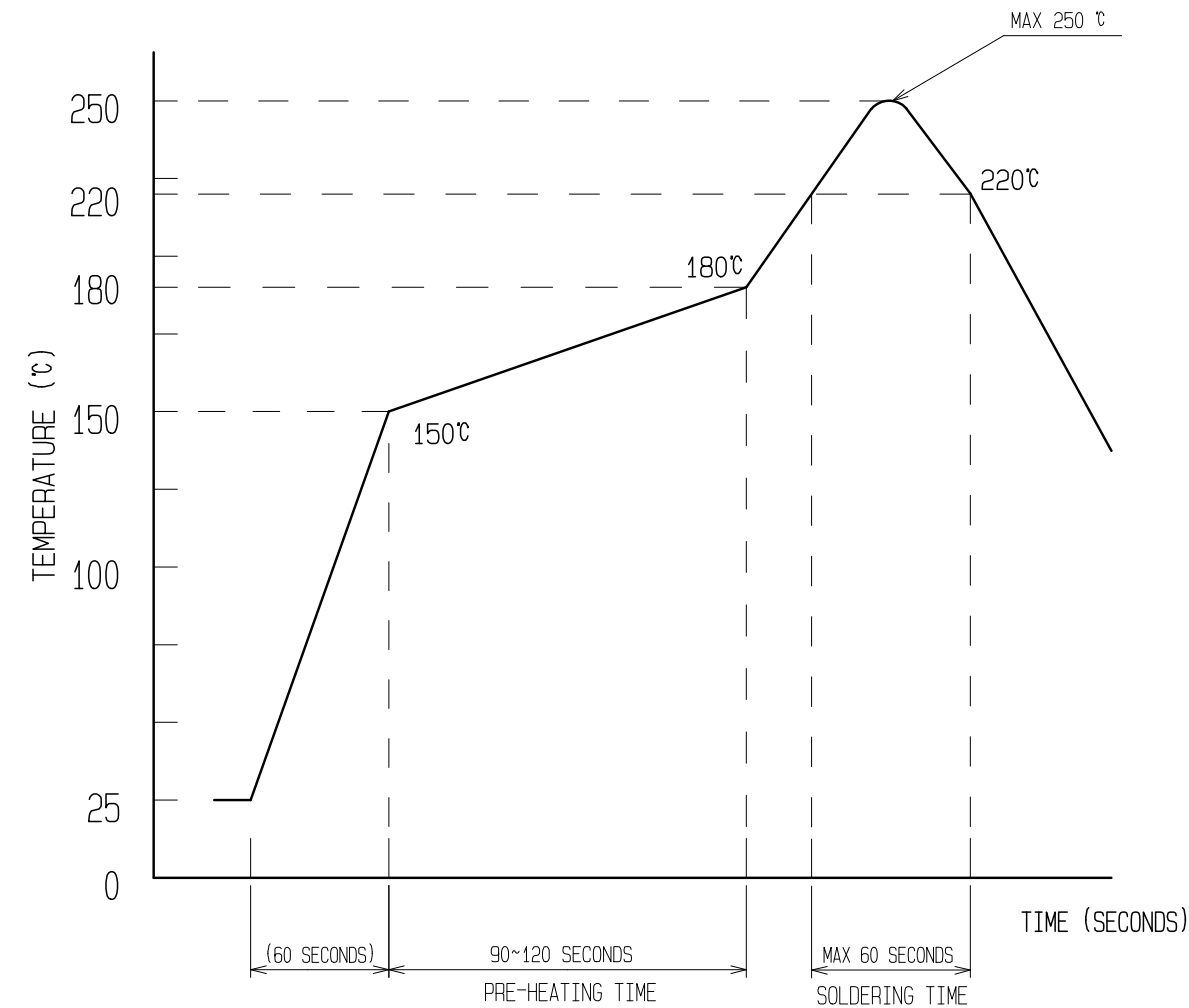

REFLOW METHOD : N₂ REFLOW
 NUMBER OF REFLOW CYCLES : 2 CYCLES MAX.
 1) REFLOW TIME
 DURATION ABOVE 220°C, 60 SEC MAX.
 (PEAK TEMPERATURE : 250°C MAX)
 2) PRE-HEAT TIME
 PRE-HEAT TEMPERATURE(MIN): 150°C
 PRE-HEAT TEMPERATURE(MAX): 180°C
 PRE-HEAT TIME: 90-120 SEC.

- 4. THIS TEMPERATURE PROFILE IS PER THE CONDITIONS SHOWN ABOVE. ADDITIONAL FACTORS SUCH AS SOLDER PASTE TYPE, PCB SIZE AND OTHER MOUNTED COMPONENTS COULD AFFECT THE PROFILE. THEREFORE, A THOROUGH EVALUATION OF MOUNTING CONDITION IS REQUIRED PRIOR TO PRODUCTION. TEMPERATURE IS MEASURED AT CONTACT LEAD.
- 5. PLEASE CONTACT US IN CASE YOU WILL MAKE DIFFERENT SETTINGS FROM OUR RECOMMENDATION.
- 6. THIS PRODUCT SATISFIES HALOGEN FREE REQUIREMENTS DEFINED AS 900ppm MAXIMUM CHLORINE, 900ppm MAXIMUM BROMINE, AND 1500ppm MAXIMUM TOTAL OF CHLORINE AND BROMINE.
- 7. THIS PRODUCT COMPLY WITH RoHS.

	DRAWING NO.	EDC3-632999-80	PART NO.	BK13C06-60DS/2-0.35V(800)
	SCALE	10:1	CODE NO	CL 6665-0030-6-800
UNITS	HRS HIROSE KOREA CO., LTD.			2/3

In case of consideration for using Automotive equipment / device which demand high reliability, kindly contact our sales window correspondents.

EMBOSSED CARRIER TAPE PACKAGING (5:1)

STYLE AND DIMENSION OF REEL (FREE)

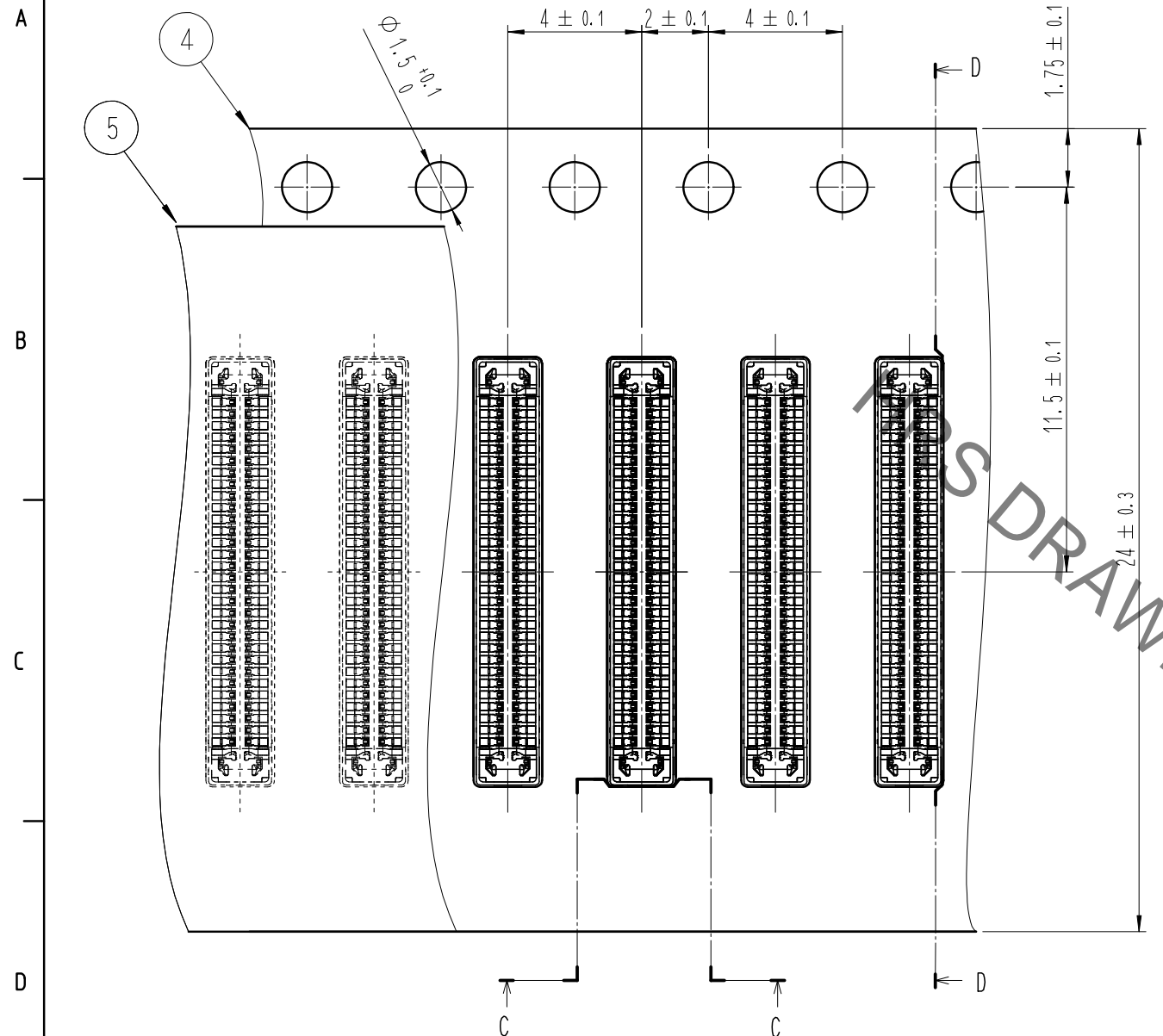

D-D (5:1)

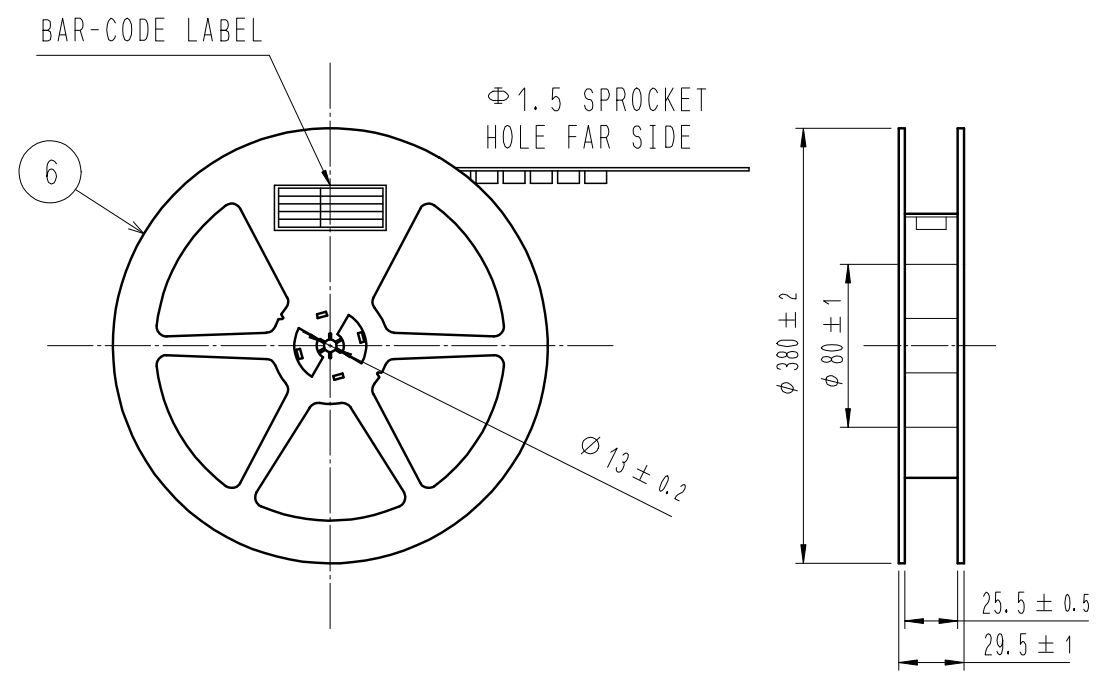
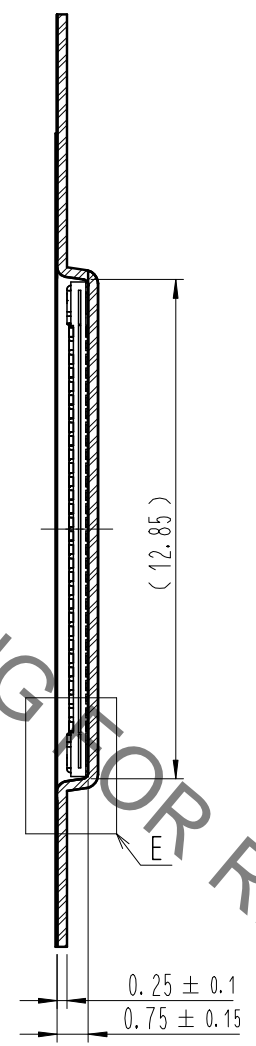

E (10:1)

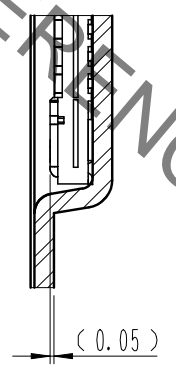

DETAIL OF PART No. LABEL

—	SUPPLIER	
—	QUANTITY	
—	PART NO.	
—	CODE NO.	
—	DATE OF MANUFACTURED	
—	生産月日	年 月 日
—	箱番	** ** *
—	品名	BK13C06-60DS/2-0.35V(800)
—	納入数量	20,000個
—	納入者	HIROSE KOREA

C-C (5:1)

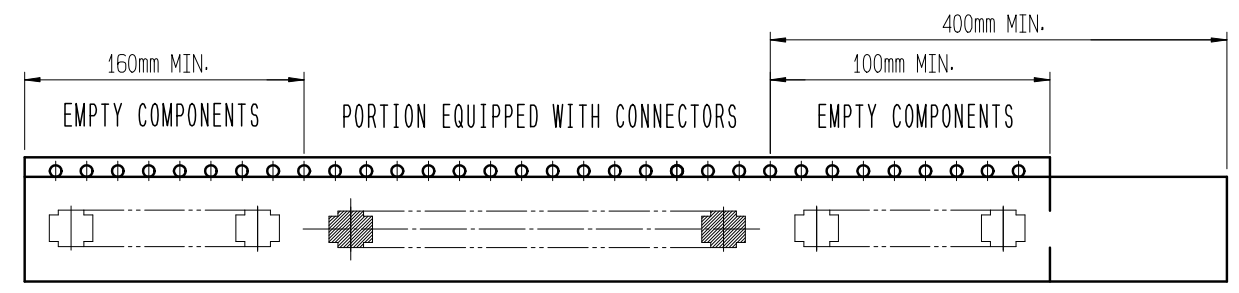
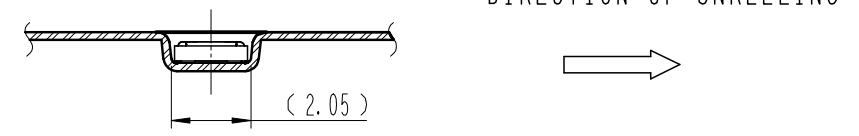

10 TAPING(FREE)

- 8 . PER REEL 20,000 CONNECTORS.
- 9 . THE DIMENSIONS IN PARENTHESES ARE FOR REFERENCE.
- 10 > REFER TO JIS C 0806, IEC-60286-3 (PACKAGING OF COMPONENTS FOR AUTOMATIC HANDLING)

	DRAWING NO.	EDC3-632999-80	PART NO.	BK13C06-60DS/2-0.35V(800)	
	SCALE	10:1	CODE NO.	CL 6665-0030-6-800	3/3
	UNITS	mm			

Mouser Electronics

Authorized Distributor

Click to View Pricing, Inventory, Delivery & Lifecycle Information:

[Hirose Electric:](#)

[BK13C06-60DS/2-0.35V\(800\)](#)