

Sep.1.2021 Copyright 2021 HIROSE ELECTRIC CO., LTD. All Rights Reserved.  
In case of consideration for using Automotive equipment / device which demand high reliability, kindly contact our sales window correspondents.

COUNT	DESCRIPTION OF REVISIONS	B	Y	CHKD	DATE	COUNT	DESCRIPTION OF REVISIONS	B	Y	CHKD	DATE
4	RE-6-1800	YDK	JHW		20. 04. 17						

### ENGAGEMENT FIGURE (50:1)

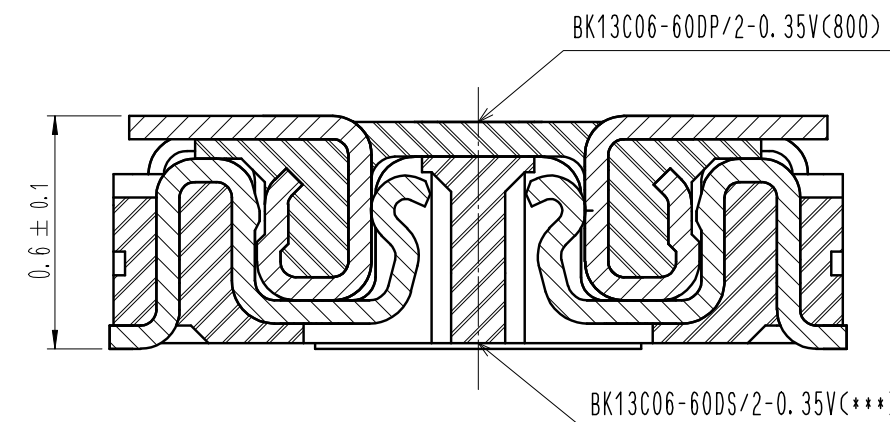

SIGNAL CONTACT

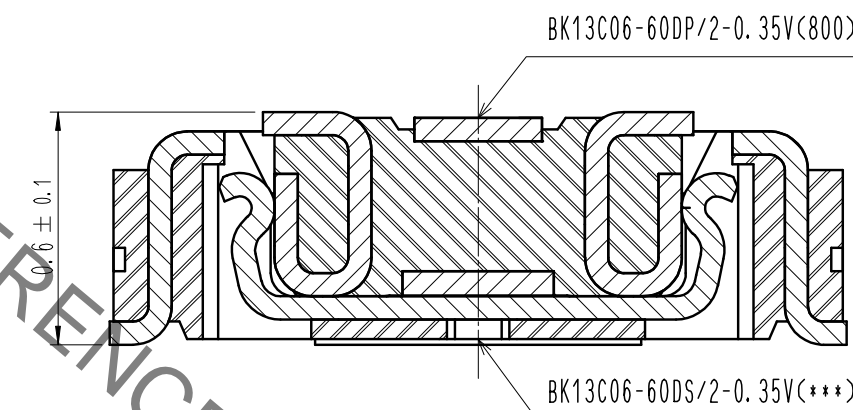

POWER CONTACT

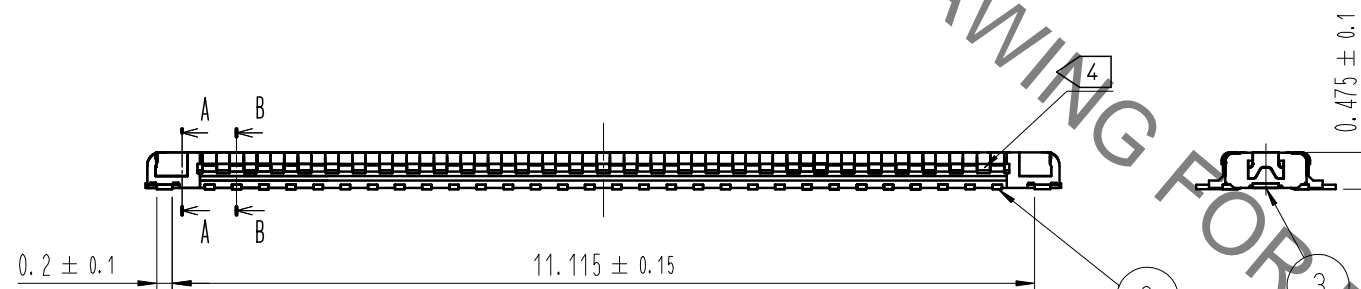
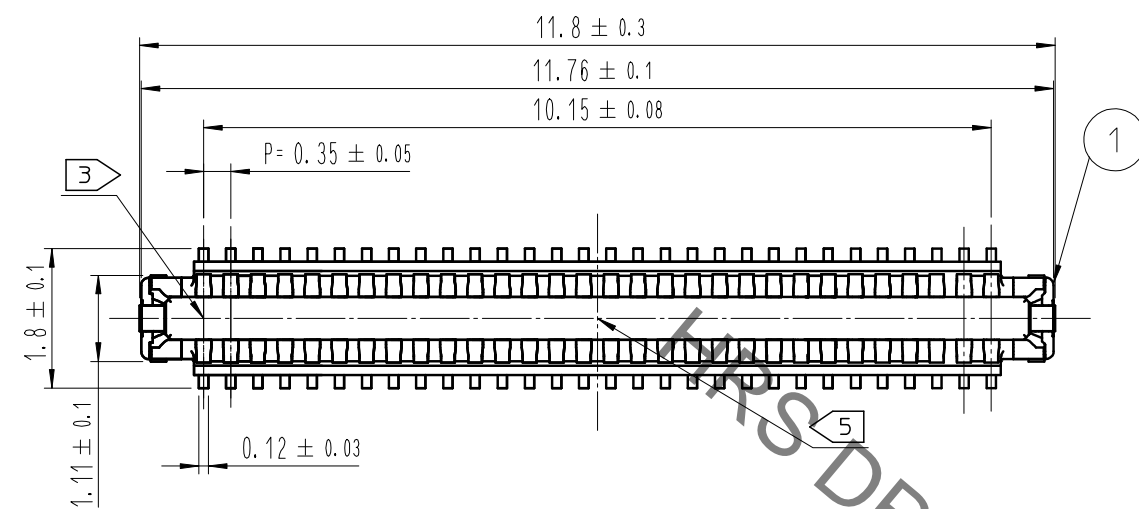

B-B (30:1)

A-A (30:1)

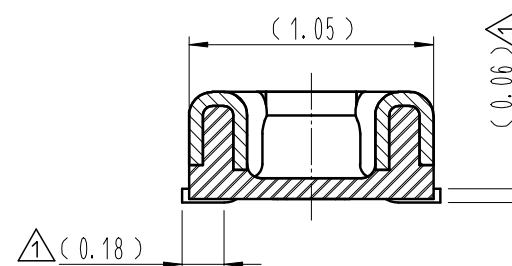
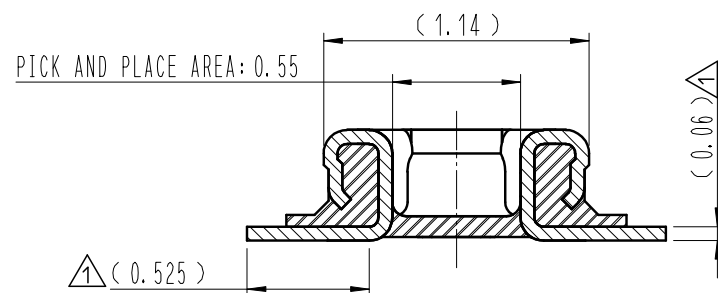

- NOTE
- 1. ALL LEAD CO-PLANARITY SHALL BE 0.08mm MAX.
  - 2. CONTACT PLATING SPECIFICATIONS  
CONTACT AREA : GOLD 0.05 μm MIN  
SMT LEAD : GOLD 0.05 μm MIN  
UNDERPLATING : NICKEL 1 μm MIN  
( SURFACE : SEALING )
  - 3. CAV NO. ARE INDICATED IN APPROX POSITION SHOWN.
  - 4. A PART OF THE WALL COULD BE NOTCHED
  - 5. DENT EXISTS IN THE INDICATED AREA FOR MANUFACTURING CONVENIENCE.

4	PS	CLEAR (EMBOSSD CARRIER TAPE)			
3	COPPER ALLOY	2			
2	COPPER ALLOY	2			
1	LCP	UL94 V-0, BLACK	6	PS	BLACK (PLASTIC REEL)
			5	POLYESTER	CLEAR (COVER TAPE)
NO.	MATERIAL	FINISH, REMARKS	NO.	MATERIAL	FINISH, REMARKS
REMARKS			DRAWN	DESIGNED	CHECKED
			H. K. JEON	H. K. JEON	H. W. JO
			20. 02. 18	20. 02. 18	20. 02. 18
			APPROVED	RELEASED	
			H. W. JO	H. W. JO	20. 02. 18
			20. 02. 18	20. 02. 18	20. 02. 18
CODE NO. (OLD)	SCALE	DRAWING NO.	PART NO.		
	10:1	EDC3-632998-80	BK13C06-60DP/2-0.35V(800)		
	UNITS	HRS HIROSE KOREA CO., LTD.	CODE NO.		
	mm		CL 6665-0031-9-800		
					1/3

Sep.1.2021 Copyright 2021 HIROSE ELECTRIC CO., LTD. All Rights Reserved.  
In case of consideration for using Automotive equipment / device which demand high reliability, kindly contact our sales window correspondents.

7 **RECOMMENDED PCB LAYOUT**

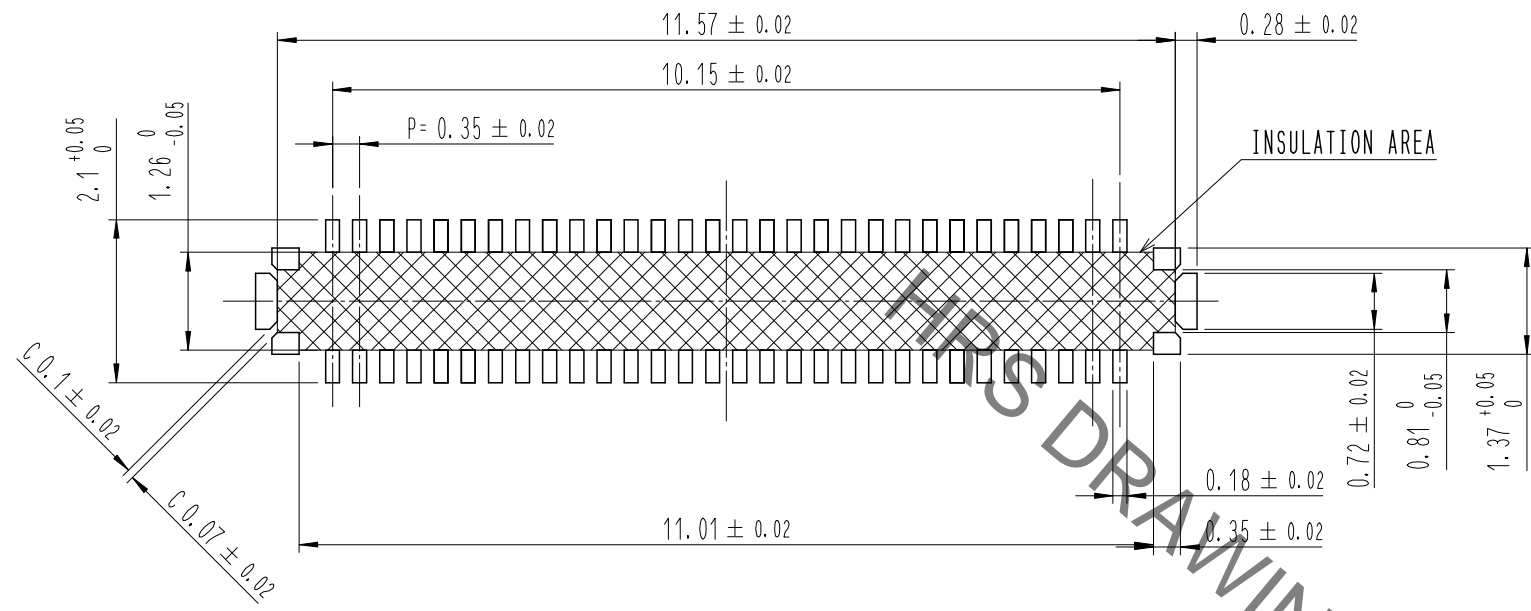

8 **RECOMMENDED METAL MASK DIMENSIONS**  
METAL MASK THICKNESS : 80 μm

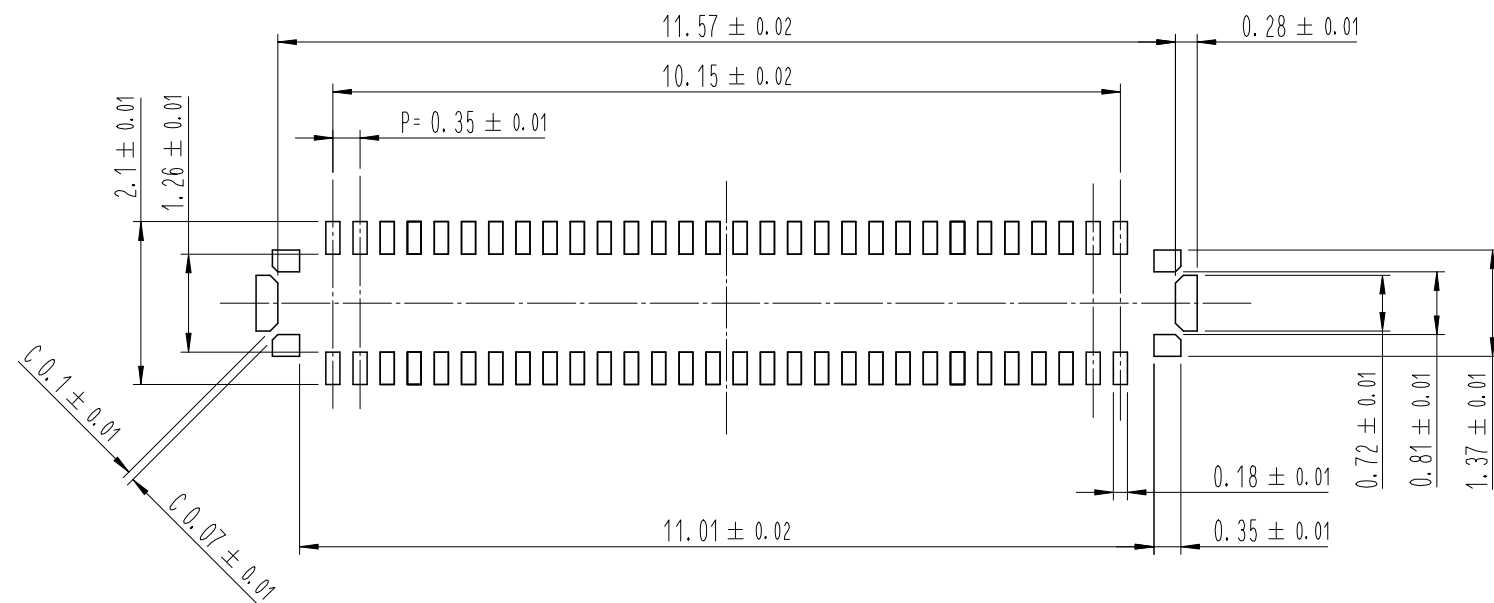

6 **RECOMMENDED REFLOW TEMPERATURE PROFILE USING LEAD-FREE SOLDER PASTE.**

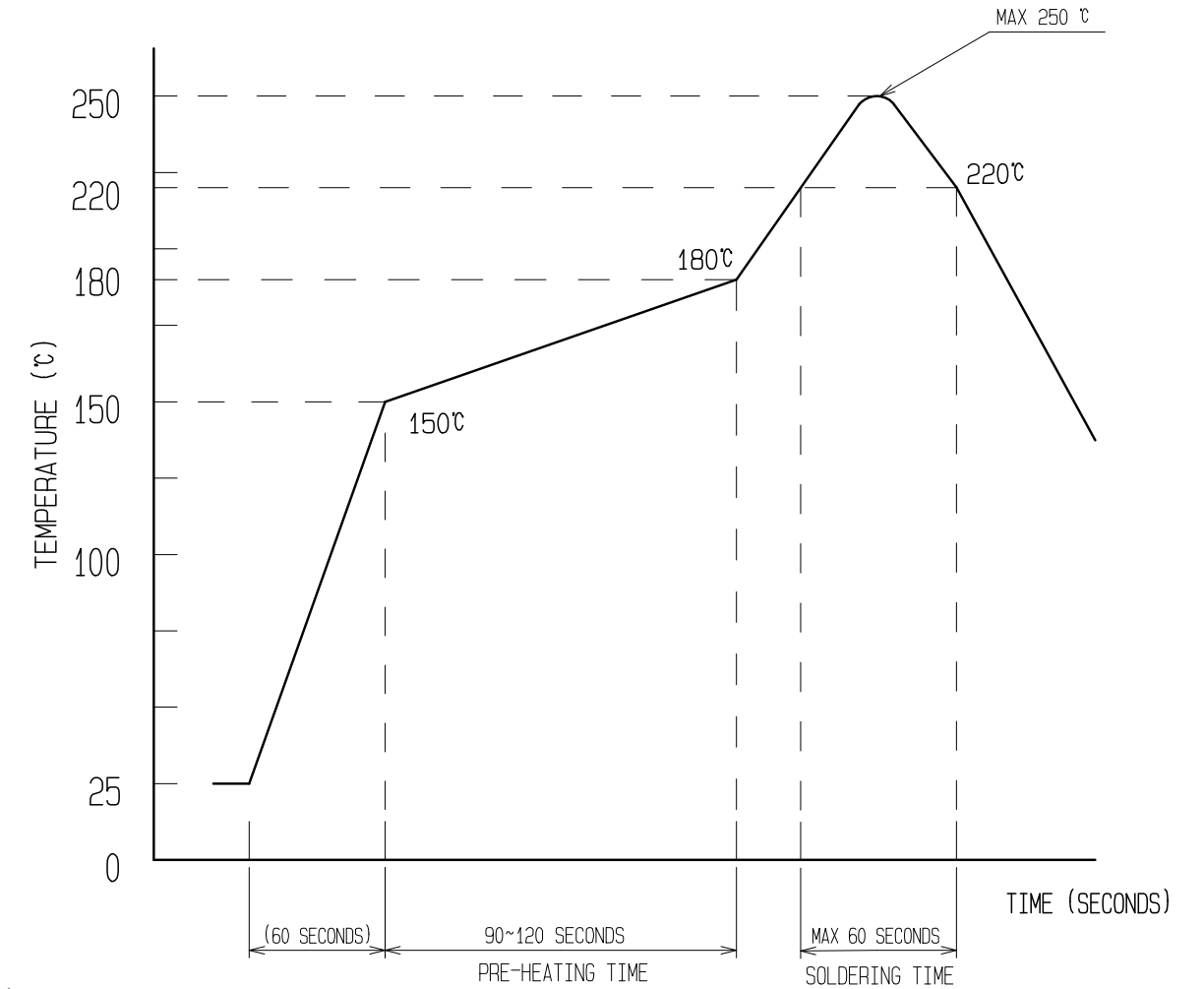

- REFLOW METHOD : N<sub>2</sub> REFLOW  
 NUMBER OF REFLOW CYCLES : 2 CYCLES MAX.  
 1) REFLOW TIME  
 DURATION ABOVE 220°C, 60 SEC MAX.  
 (PEAK TEMPERATURE : 250°C MAX)  
 2) PRE-HEAT TIME  
 PRE-HEAT TEMPERATURE(MIN): 150°C  
 PRE-HEAT TEMPERATURE(MAX): 180°C  
 PRE-HEAT TIME: 90-120 SEC.

- 6 THIS TEMPERATURE PROFILE IS PER THE CONDITIONS SHOWN ABOVE. ADDITIONAL FACTORS SUCH AS SOLDER PASTE TYPE, PCB SIZE AND OTHER MOUNTED COMPONENTS COULD AFFECT THE PROFILE. THEREFORE, A THOROUGH EVALUATION OF MOUNTING CONDITION IS REQUIRED PRIOR TO PRODUCTION. TEMPERATURE IS MEASURED AT CONTACT LEAD.
- 7 PLEASE CONTACT US IN CASE YOU WILL MAKE DIFFERENT SETTINGS FROM OUR RECOMMENDATION.
- 8 THIS PRODUCT SATISFIES HALOGEN FREE REQUIREMENTS DEFINED AS 900ppm MAXIMUM CHLORINE, 900ppm MAXIMUM BROMINE, AND 1500ppm MAXIMUM TOTAL OF CHLORINE AND BROMINE.
- 9 THIS PRODUCT COMPLY WITH RoHS.

	DRAWING NO.	EDC3-632998-80	PART NO.	BK13C06-60DP/2-0.35V(800)
	SCALE	10:1	CODE NO	CL 6665-0031-9-800
UNITS	HRS HIROSE KOREA CO., LTD.			2/3

Sep.1.2021 Copyright 2021 HIROSE ELECTRIC CO., LTD. All Rights Reserved.  
In case of consideration for using Automotive equipment / device which demand high reliability, kindly contact our sales window correspondents.

# EMBOSSED CARRIER TAPE PACKAGING (5:1)

# STYLE AND DIMENSION OF REEL (FREE)

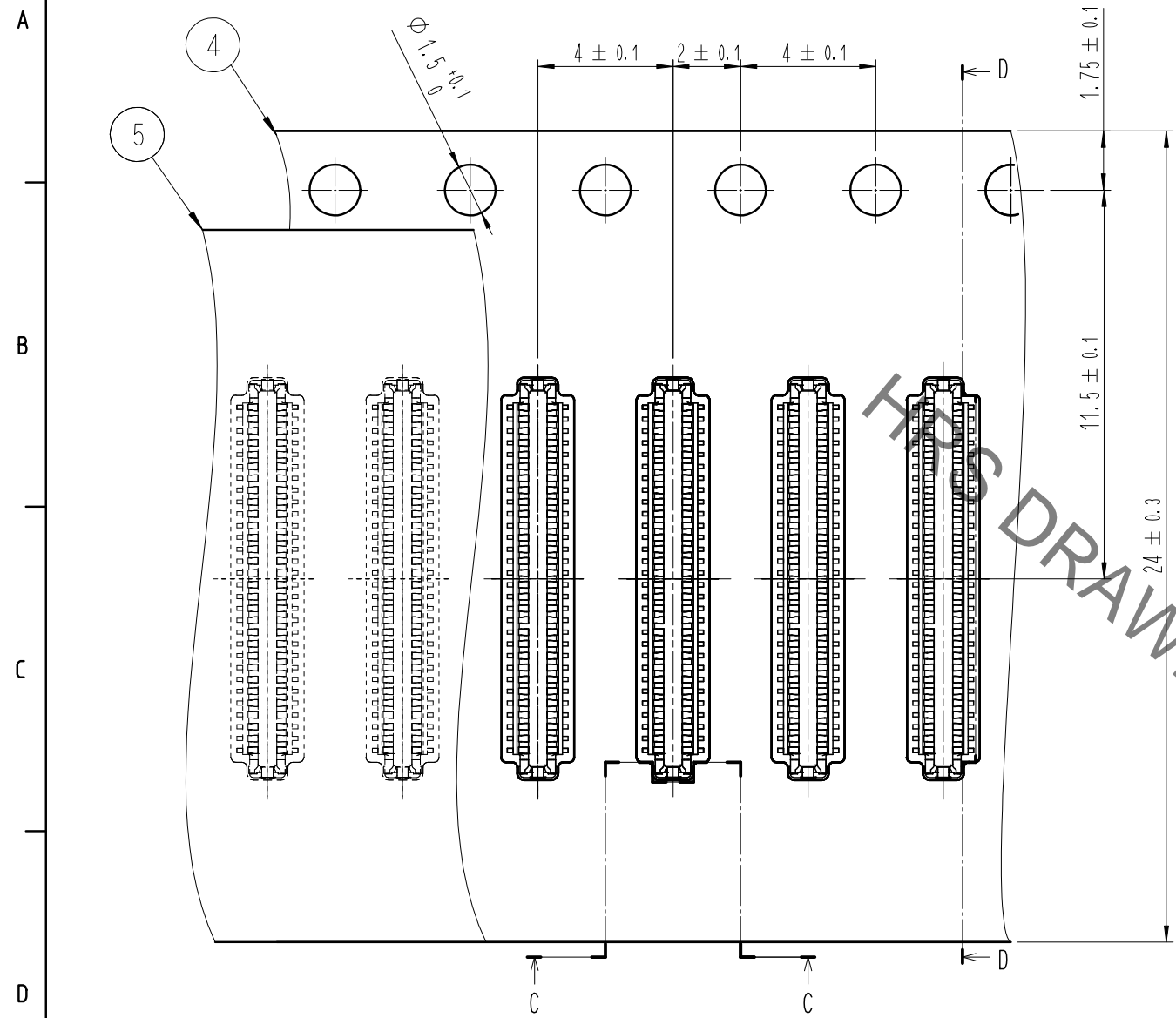

D-D (5:1)

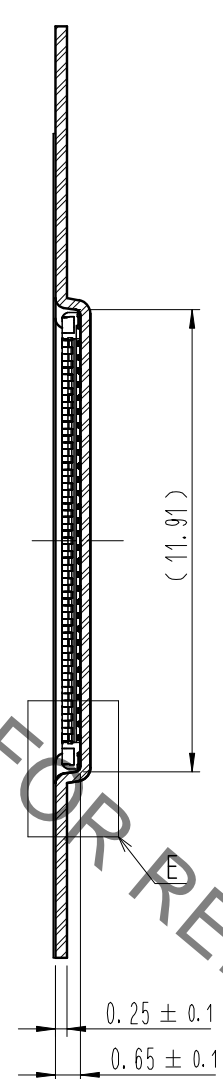

BAR-CODE LABEL

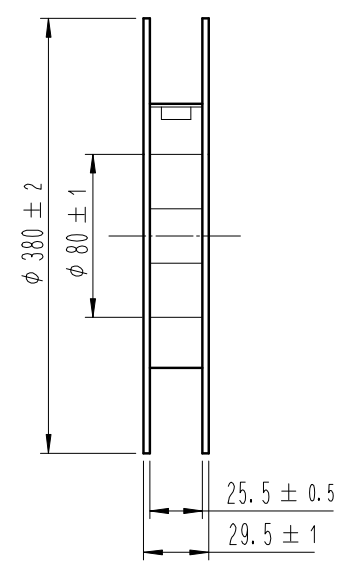
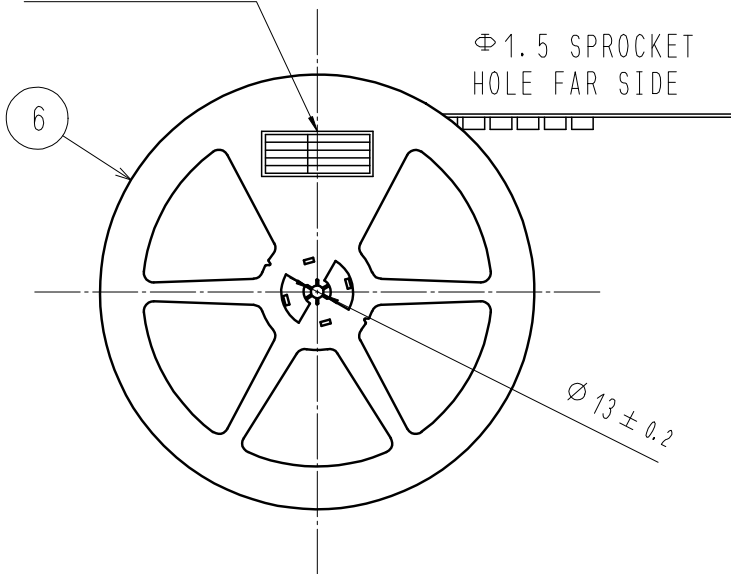

C-C (5:1)

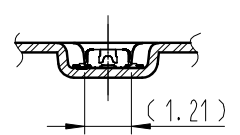

DIRECTION OF UNREELING

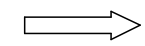

E (10:1)

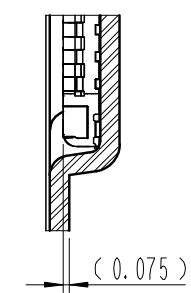

DETAIL OF PART No. LABEL

SUPPLIER	HIROSE ELECTRIC CO., LTD.
QUANTITY	20,000
PART NO.	BK13C06-60DP/2-0.35V(800)
CODE NO.	CL 6665-0031-9-800
DATE OF MANUFACTURED	生産月日 年 月 日
箱番	** ** *
品名	BK13C06-60DP/2-0.35V(800)
納入数量	20,000個
納入者	HIROSE KOREA

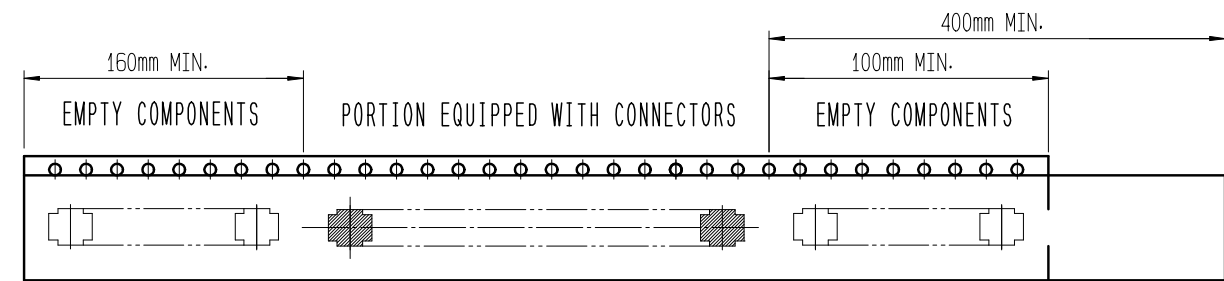

TRAILER

LEADER

TAPING(FREE)

- 10 . PER REEL 20,000 CONNECTORS.
- 11 . THE DIMENSIONS IN PARENTHESES ARE FOR REFERENCE.
- 12 > REFER TO JIS C 0806, IEC-60286-3 (PACKAGING OF COMPONENTS FOR AUTOMATIC HANDLING)

 SCALE 10:1 UNITS mm	DRAWING NO.	EDC3-632998-80	PART NO.	BK13C06-60DP/2-0.35V(800)	
	 HIROSE KOREA CO., LTD.		CODE NO.	CL 6665-0031-9-800	3/3

# Mouser Electronics

Authorized Distributor

Click to View Pricing, Inventory, Delivery & Lifecycle Information:

[Hirose Electric:](#)

[BK13C06-60DP/2-0.35V\(800\)](#)