

THIS DOCUMENT IS SUBJECT TO CHANGE WITHOUT NOTICE. IT IS CONFIDENTIAL AND A PROPERTY OF AMPHENOL LTW. DISCLOSURE TO THIRD PARTY HAS TO BE AUTHORIZED BY AMPHENOL LTW.

REV.	ECN NO.	DATE	SIGN	DESCRIPTION
B	LEN-8B0555	2008/09/19	Shin	Add Note and Update Drawing to New Format

ALTW
CONFIDENTIAL
 2012-03-08
R&D DEPT.

ALTW
 DCC. DEPT.
 CONFIDENTIAL
 2012-03-21
ISSUED

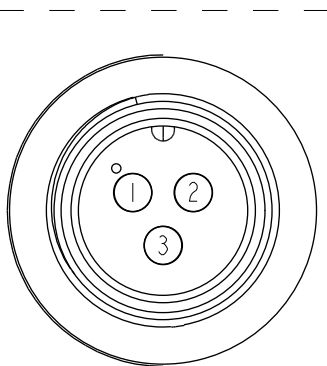
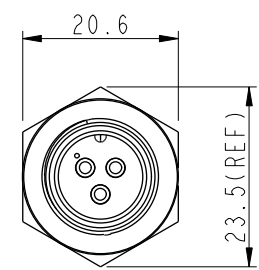
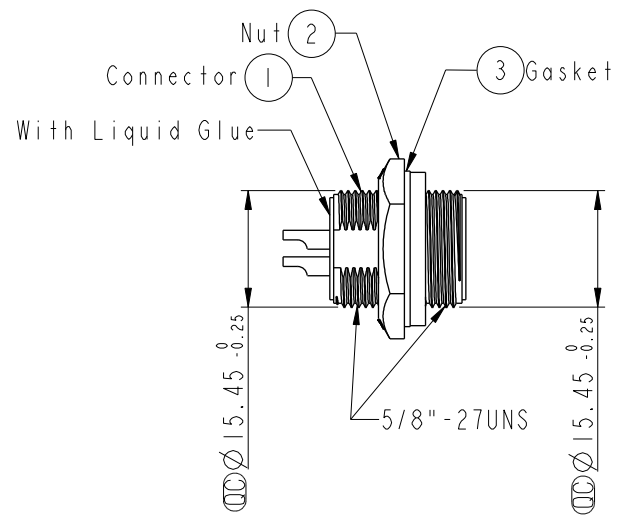
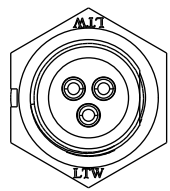

Pin Assignments
 Front View

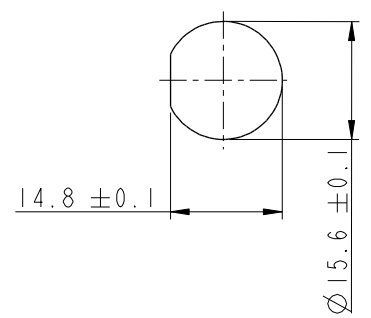

Recommended Panel Cut-Out

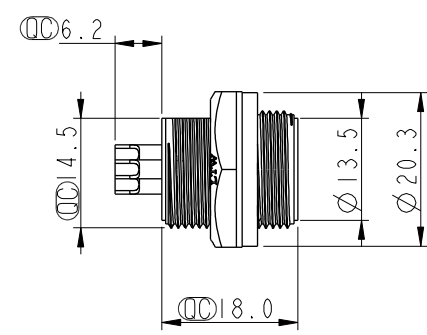

Note:

- * \varnothing Important Dimension To Check.
- * Waterproof Rate : IP67
- * Housing: Nylon+GF, Black
- * Male Pin: Copper Alloy, Gold Plated
- * Nut: Nylon+GF, Black
- * Gasket: EPDM, Black
- $\triangle B$ * Use with waterproof cap or dust cap
 Panel Thickness Max: 4.0mm
- $\triangle A$ * Use without waterproof cap or dust cap
 Panel Thickness Max: 5.0mm

UNIT:mm	
TOLERANCE	
.X	±0.25
.XX	±0.1
.XXX	±0.05
ANGLES	±1°

TITLE Standard, Rear Screw 3P M Conn M Pin			
SCALE 1:1	SIZE A4	SHEET 1 OF 1	
REV. B	WC-REV. A.2	\varnothing : Inspection item	

Amphenol LTW
 安費諾亮泰企業股份有限公司

ITEM NO. BB-03RMMS-SC7001	DRAWN BY SamChang	DATE 2012-03-08
DWG NO. BB-03RMMS-SC7001	CHECKED BY Jeffrey	DATE 2012-03-21
CUSTOMER ALTW	APPROVED BY Kevin	DATE 2012-03-21

Mouser Electronics

Authorized Distributor

Click to View Pricing, Inventory, Delivery & Lifecycle Information:

[Amphenol:](#)

[BB-03RMMS-SC7001](#)