

NOTES:

1. MATERIALS AND FINISHES:
 BODY, LOCKWASHER, HEX NUT - STAINLESS STEEL, PASSIVATED
 CONTACT - BeCu, GOLD PLATING
 BULLET CONTACT, SLEEVE, INNER FERRULE - BRASS, GOLD PLATING
 INSULATOR - PTFE
2. ELECTRICAL:
 A. IMPEDANCE: 50 OHM
 B. FREQUENCY RANGE: DC - 6 GHz
 D. VSWR: 1.3 FROM DC TO 6 GHz
 C. DIELECTRIC WITHSTANDING VOLTAGE: 500 VRMS
3. MECHANICAL:
 A. DURABILITY: 500 CYCLES MIN.
 B. TEMPERATURE RANGE: -65° C TO +165° C
4. PACKAGING:
 A. QUANTITY: SINGLE PACK
 B. MARKING: BAG TO BE MARKED
 "AMPHENOL RF, 901-10460, AND DATE CODE"
5. CABLE ASSEMBLY INSTRUCTIONS:
 A. STRIP CABLE TO DIMENSIONS SHOWN.
 B. INSERT CABLE THROUGH INNER FERRULE, AND PEEL BRAID BACK, OVER INNER FERRULE.
 C. INSTALL SLEEVE, AND INSULATOR DISC OVER CABLE DIELECTRIC, BOTTOMING ON INNER FERRULE.
 D. SOLDER BULLET CONTACT TO CABLE CENTER CONDUCTOR, BOTTOMING ON INSULATOR DISC.
 E. INSERT CABLE INTO CONNECTOR UNTIL IT BOTTOMS.
 F. CRIMP BODY OVER INNER FERRULE USING .105" HEX.

6 SHOWS CABLE ENTRY DIMENSIONS.

7. MAX PANEL THICKNESS 3.0 mm

THIRD ANGLE PROJ.

REVISIONS

REV	DESCRIPTION	DATE	ECO	APPR
A	RELEASE TO MFG.	24-Feb-15	50372	JTS

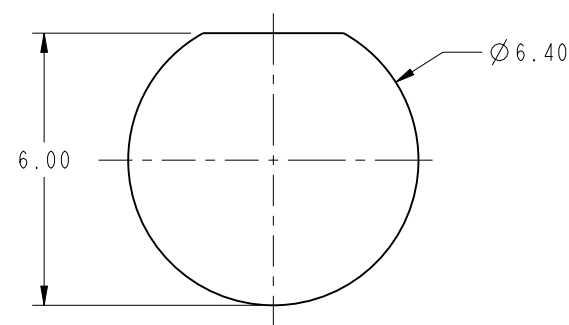

RECOMMENDED MOUNTING HOLE DIMENSIONS

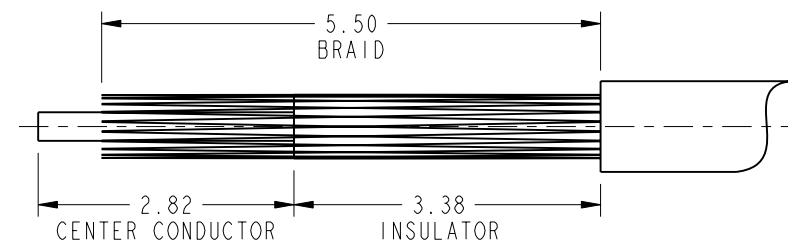

RECOMMENDED CABLE STRIPPING DIMENSIONS

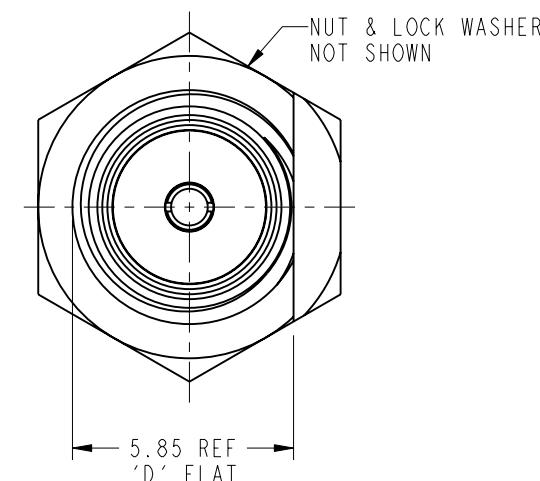
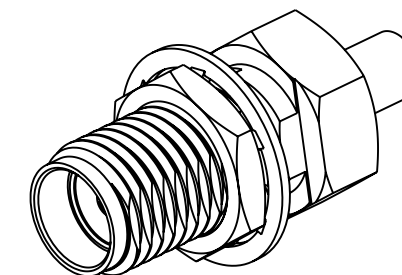

SCALE 5.000

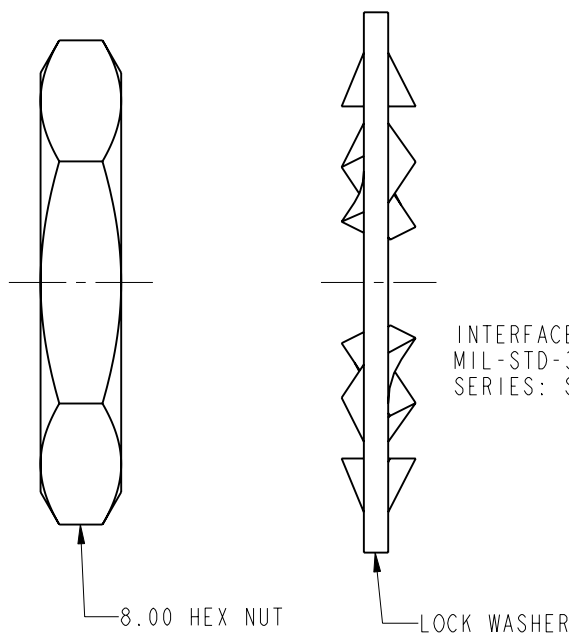

INTERFACE PER:
MIL-STD-348
SERIES: SMA JACK

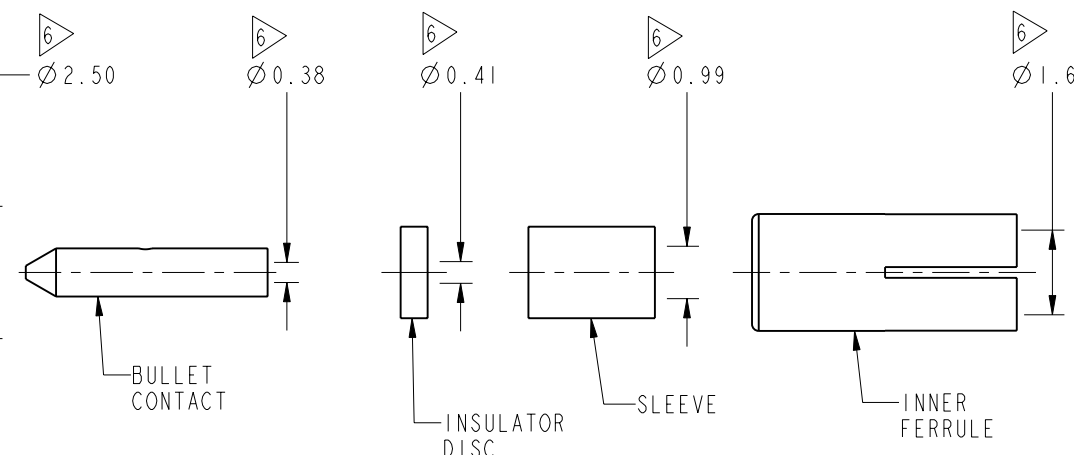
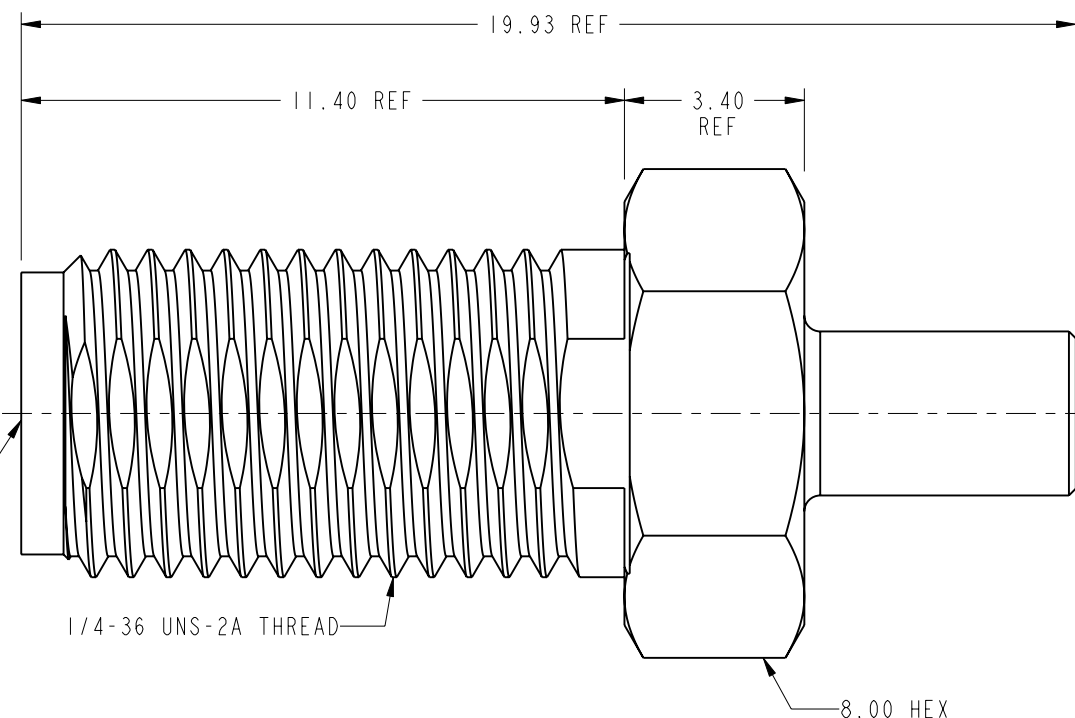

CUSTOMER OUTLINE DRAWING

ALL OTHER SHEETS ARE FOR INTERNAL USE ONLY

UNLESS OTHERWISE SPECIFIED, DIMENSIONS ARE IN METRIC AND TOLERANCES ARE: <0.5mm ±0.05mm 0.5 - 6mm ±0.1mm 6 - 30mm ±0.2mm 30 - 120mm ±0.3mm ANGLES ±1°	MATERIAL	DRAWN	DATE	TITLE SMA STR BHD JACK FOR 1.37 MM CABLE		Amphenol RF www.amphenolrf.com	
	SEE NOTES	R.MAO	13-Feb-15				
	REFERENCE	ENGINEER	DATE	SCALE: 7.0:1.0 SHEET 2 OF 2		DRAWING NO. 901-10460	
	EAR # 5838	CLEMENT	07-Aug-13				
NOTICE - These drawings, specifications, or other data (1) are, and remain the property of Amphenol corp. (2) must be returned upon request; and (3) are confidential and not to be disclosed to any person other than those to whom they are given by Amphenol Corp. the furnishing of these drawings, specifications, or other data by Amphenol Corp., or to any other person for any purpose is not to be regarded by implication or otherwise in any manner licensing, granting rights to permitting such holder or any other person to manufacture, use or sell any product, process or design, patented or otherwise, that may in any way be related to or disclosed by said drawings, specifications, or other data.	CONFIGURATION LEVEL: In Work	APPROVED	DATE	DWG SIZE REV B A		ITEM NO. 901-10460 PART NO. 901-10460	
FINISH	S.HSIEH	24-Feb-15					

Mouser Electronics

Authorized Distributor

Click to View Pricing, Inventory, Delivery & Lifecycle Information:

[Amphenol:](#)

[901-10460](#)