

REV.	ECN NO.	DATE	SIGN	DESCRIPTION
D	LEN-9C0088	2009/12/14	Vicky	REF. TO ECR/N. NOTE.
E	LEN1741230	2017/04/13	Ruru	Change Logo
F	CI90268	2019/03/05	Ruru	Modify Note

**ALTW**  
**CONFIDENTIAL**  
 2019-03-05  
 R&D DEPT.

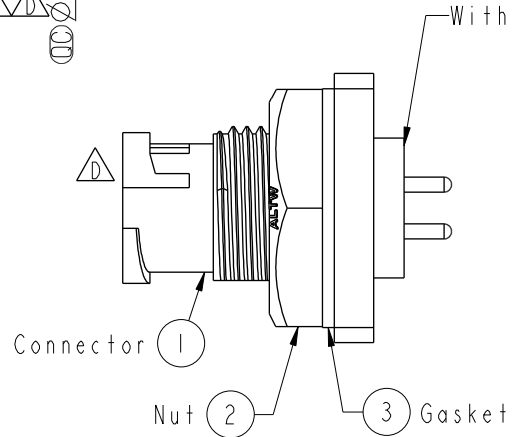
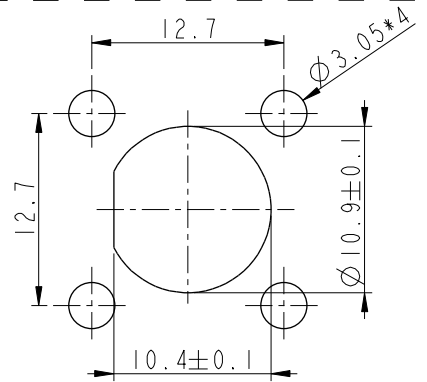
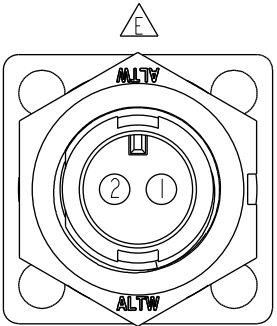
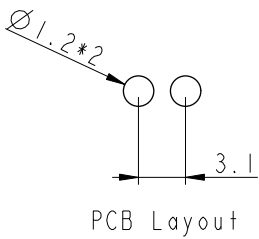
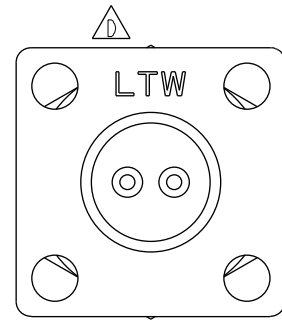
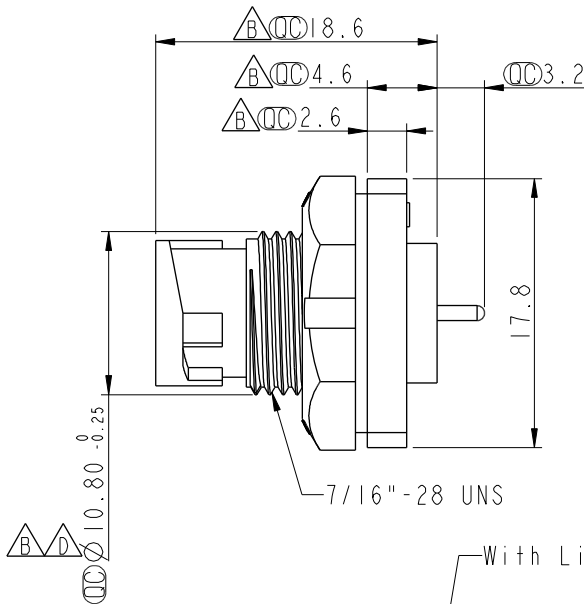
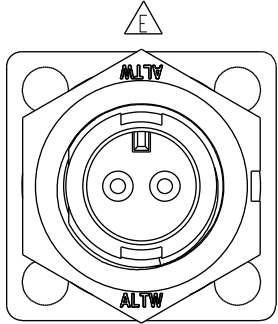

- Note:  $\triangle$
- \*  $\text{⌀}$  Important Dimension.
  - \* Waterproof Rate: IP67, Unmated
  - \* Housing: Thermoplastic, Black
  - \* Pin: Copper Alloy, Gold Plated
  - $\triangle$  \* Shield: Metal, Nickel Plated
  - \* Nut: Thermoplastic, Black
  - \* Gasket: Rubber, Black
  - $\triangle$  \* Use with waterproof cap or dust cap  
Panel Thickness Max. 2.5mm.
  - $\triangle$  \* Use without waterproof cap or dust cap  
Panel Thickness Max. 3.5mm.
  - \* Gasket and Nut are packed separately in PE bags.

UNIT:mm

TOLERANCE	
.X	±0.25
.XX	±0.1
.XXX	±0.05
ANGLES	±1°

TITLE Mini Panel Lock 2Pin M Conn. M Pin			
SCALE 2:1	SIZE A4	SHEET 1 OF 1	
REV. F	WC-REV. A.2	$\text{⌀}$ : Inspection item	

**Amphenol LTW**  
 安費諾亮泰企業股份有限公司

ITEM NO ASD-02PMMP-LS7001	DRAWN BY Ruru	DATE 2019-03-05
DWG NO ASD-02PMMP-LS7001	CHECKED BY Rita	DATE 2019-03-05
CUSTOMER ALTW	APPROVED BY Max	DATE 2019-03-05

THIS DOCUMENT IS SUBJECT TO CHANGE WITHOUT NOTICE. IT IS CONFIDENTIAL AND A PROPERTY OF Amphenol LTW. DISCLOSURE TO THIRD PARTY HAS TO BE AUTHORIZED BY Amphenol LTW.

# Mouser Electronics

Authorized Distributor

Click to View Pricing, Inventory, Delivery & Lifecycle Information:

[Amphenol:](#)

[ASD-02PMMP-LS7001](#)