

10086534-X MM DD Y Y LF

LEAD FREE
 OVERALL LENGTH IN CENTIMETER
 OVERALL LENGTH IN METER
 EXAMPLE OF MM DD: 1.5M CABLE= 0150
 5M CABLE= 0500
 SIGNAL WIRE GAGE
 N: 26 AWG

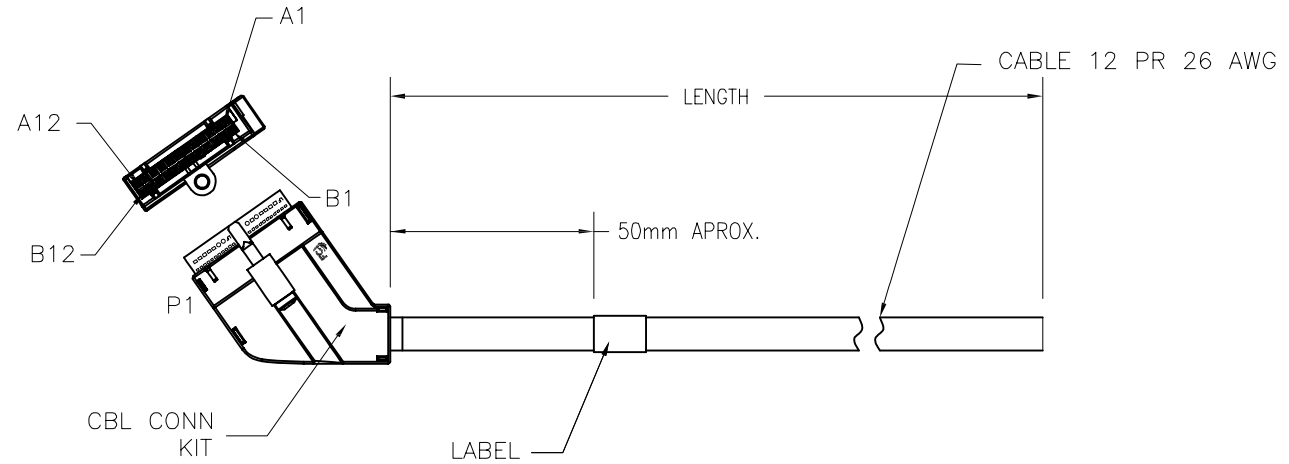

WIRING DIAGRAM		
POS P1-P2	COLOR CODE	TWISTED PAIR
B1	BLUE	1
A2	WHITE	
B2	ORANGE	2
A1	WHITE	
B3	GREEN	3
A4	WHITE	
B4	BROWN	4
A3	WHITE	
B5	BLUE	5
A6	RED	
B6	ORANGE	6
A5	RED	
B7	GREEN	7
A8	RED	
B8	BROWN	8
A7	RED	
B9	BLUE	9
A10	BLACK	
B10	ORANGE	10
A9	BLACK	
B11	GREEN	11
A12	BLACK	
B12	BROWN	12
A11	BLACK	

NOTES:

- ELECTRICAL TEST: CONTINUITY, HI POT TEST, RESISTANCE NO LESS THAN 2Mohms, 10mS.
- PART NUMBER WITH "LF" SUFFIX AT THE END ARE LEAD FREE.
- LABEL INFORMATION:
 FCI
 FCI PART NO.
 DATE CODE
 COUNTRY ORIGIN
- TOLERANCES:
 0-1 = ±15mm
 1-10 = ± 2%
 <10 = ± 4%
- PACKAGE PER GS-14-920 FOR LEAD FREE PACKAGING REQUIREMENTS.

mat'l. code		surface ISO 1302 ✓		tolerance ISO 406 ISO 1101		projection METER		product family CABLE ASSEMBLY	
ltr	ecn no	dr	date	tolerances unless otherwise specified		SEE TABLE		title SIGNAL CABLE ASSEMBLY OPEN END	
A	M08-0039	AGS	02/12/08	angles	linear	METER		dwg no 10086534	
B	M08-0105	AGS	04/11/08			scale NTS		sheet 1 of 1 size A3	
		dr	A. GARCIA	02/12/08	FCI		type Product Customer Drawing		
		enrg	J.DUARTE	02/12/08					
		chr	J.DUARTE	02/12/08					
		appd	J.DUARTE	02/12/08					
sheet index	revision	B							
	sheet	1							



This document is the property of and embodies CONFIDENTIAL and PROPRIETARY information of FCI. No part of the information shown on this document may be used in any way or disclosed to others without the written consent of FCI.
 Copyright FCI

Mouser Electronics

Authorized Distributor

Click to View Pricing, Inventory, Delivery & Lifecycle Information:

[FCI / Amphenol:](#)

[10086534-N0320YYLF](#)