

| REVISIONS | | | | |
|-----------|-----|------------------------|-----------|--------------|
| REV | ECO | DESCRIPTION | DATE | BY APPR |
| A1 | - | RELEASED DRAWING | Nov-9-17 | Rookie Tommy |
| A2 | - | ADD THE GS PART NUMBER | Jan-28-19 | Blirik Tommy |

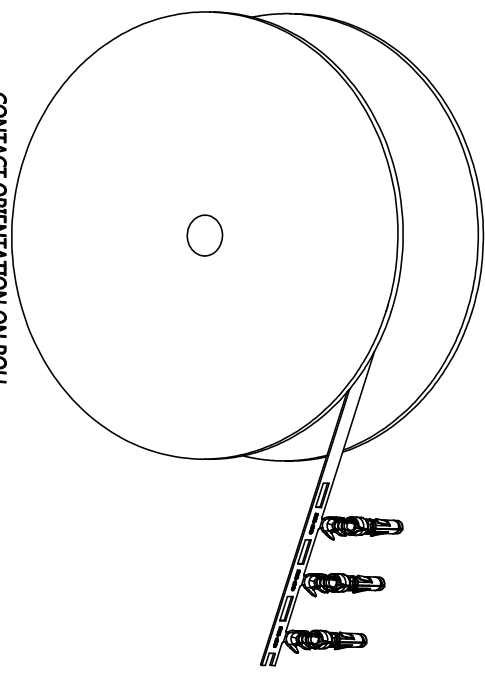

CONTACT ORIENTATION ON ROLL

NOTES : (UNLESS OTHERWISE SPECIFIED)

1. MATERIAL :
 - 1.1. CONTACT BODY : COPPER ALLOY.
 - 1.2. OUTER SPRING : STAINLESS STEEL.
2. SPECIFICATIONS :
 - 2.1 CURRENT RATING : 5A MAX.
 - 2.2 TERMINATION TYPE : CRIMPING.
 - 2.3 WIRE RANGE : 22~20AWG.
 - 2.4 WIRE INSULATION DIA(MAX) : Ø2.6mm.
3. ROHS COMPLIANT.
4. ALL DIMENSIONS ARE FOR REFERENCE USE ONLY.
5. AVAILABLE TOOLS :
 - 5.1 HAND CRIMPER : MFX-3954.
 - 5.2 CRIMP APPLICATOR : MFX-3957.
 - 5.3 EXTRACTION TOOL : QXRT20.

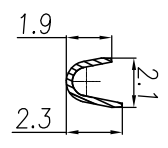
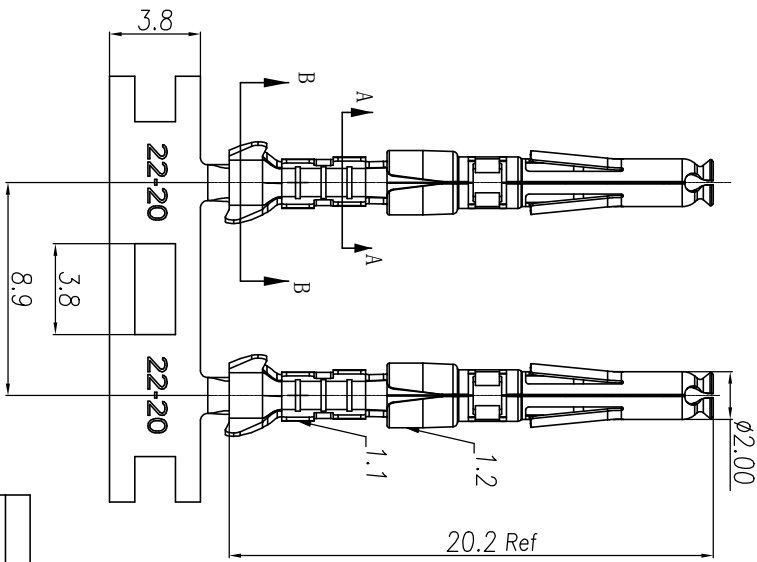

SECTION A-A

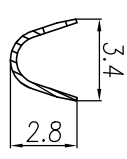

SECTION B-B

| P/N | CONTACT PLATING(MATING AREA) |
|-----------|---------------------------------|
| SS20W2T | TIN PLATING OVER NICKEL. |
| SS20W2N | NICKEL PLATING OVER COPPERIZE. |
| SS20W2F | GOLD FLASH PLATING OVER NICKEL. |
| SS20W2G5 | 5µ" GOLD PLATING OVER NICKEL. |
| SS20W2G10 | 10µ" GOLD PLATING OVER NICKEL. |
| SS20W2G15 | 15µ" GOLD PLATING OVER NICKEL. |
| SS20W2G30 | 30µ" GOLD PLATING OVER NICKEL. |

A2

| QUANTITY | PART NUMBER | DESCRIPTION | ITEM |
|--|-------------|---|------|
| | | MATERIALS LIST | |
| <p>UNLESS OTHERWISE SPECIFIED</p> <p>1) All dimensions are in metric(mm).</p> <p>2) Tolerances are as follows:</p> <p>3 PL DEC 2018 Angles ±1°</p> <p>3) Note reference = </p> | | | |
| <p>MATERIAL SPECIFICATIONS:</p> <p>CUSTOMER: Tommy DATE: Jan-28-19</p> <p>APPROVAL: Tommy DATE: Jan-28-19</p> | | | |
| <p>PROCESS SPECIFICATIONS:</p> <p>THIS DRAWING IS SUPPLIED FOR INFORMATION ONLY. DESIGN FEATURES, INFORMATION, CORROSION, NO RIGHTS SHOWN. HEREON ARE THE PROPERTY OF SINE SYSTEMS. ALL DIMENSIONS ARE SUBJECT TO NORMAL MANUFACTURING VARIATIONS.</p> | | | |
| <p>SIZE: B</p> <p>TYPE: C-</p> <p>SCALE: NONE</p> | | <p>DWG NO: SS20W2XX</p> <p>DATE: 20-22AWG, SIZE 20</p> <p>STAMPED: 20-22AWG, SIZE 20</p> | |
| <p>ECO-MATE SOCKET CONTACT,</p> | | <p>ECO-MATE SOCKET CONTACT,</p> | |
| <p>Sine Systems - www.amphenol-sine.com</p> <p>44724 Morley Drive</p> <p>Clinton Township, MI 48036</p> | | <p>44724 Morley Drive</p> <p>Clinton Township, MI 48036</p> | |
| <p>STAMPED: SS20W2XX</p> | | <p>STAMPED: SS20W2XX</p> | |
| <p>SHEET 1 OF 1</p> | | <p>SHEET 1 OF 1</p> | |

Mouser Electronics

Authorized Distributor

Click to View Pricing, Inventory, Delivery & Lifecycle Information:

[Amphenol:](#)

[SS20W2T](#)