

REVISIONS				
REV	ECO	DESCRIPTION	DATE	BY APPR
A1	-	RELEASED DRAWING	Jul-16-18	Flan Tommy

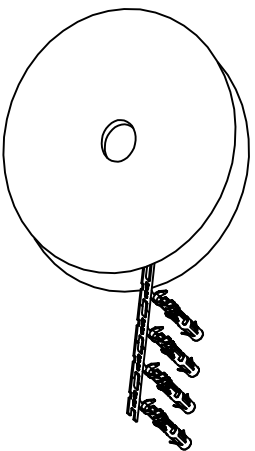

CONTACT ORIENTATION ON ROLL (3000PCS/COIL)

NOTES : (UNLESS OTHERWISE SPECIFIED)

1. MATERIAL :
  - 1.1. CONTACT BODY : COPPER ALLOY.
  - 1.2. OUTER SPRING : STAINLESS STEEL.
2. SPECIFICATIONS :
  - 2.1 CURRENT RATING : 13A MAX.
  - 2.2 TERMINATION TYPE : CRIMPING.
  - 2.3 WIRE RANGE : 20~22AWG.
  - 2.4 WIRE INSULATION DIA(MAX) :  $\phi$ 2.5mm.
3. ROHS COMPLIANT.
4. ALL DIMENSIONS ARE FOR REFERENCE USE ONLY.
5. AVAILABLE TOOLS :
  - 5.1 HAND CRIMPER : MFX-3954.
  - 5.2 CRIMP APPLICATOR : MFX-3957.
  - 5.3 EXTRACTION TOOL : QXRTL16.

P/N	CONTACT PLATING(MATING AREA)
SS20M2T	TIN PLATING OVER NICKEL.
SS20M2N	NICKEL PLATING OVER COPPERIZE.
SS20M2F	GOLD FLASH PLATING OVER NICKEL.
SS20M2G5	5 $\mu$ "GOLD PLATING OVER NICKEL.
SS20M2G10	10 $\mu$ "GOLD PLATING OVER NICKEL.
SS20M2G15	15 $\mu$ "GOLD PLATING OVER NICKEL.
SS20M2G30	30 $\mu$ "GOLD PLATING OVER NICKEL.

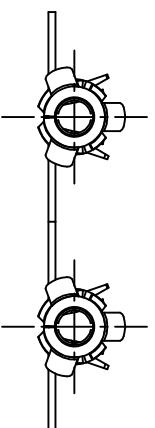
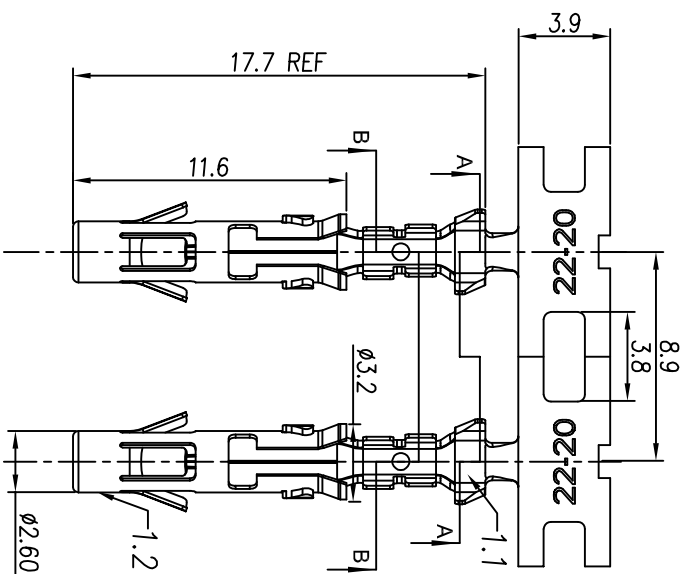
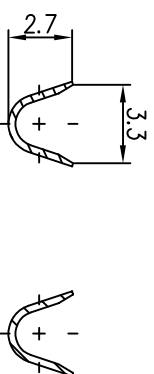
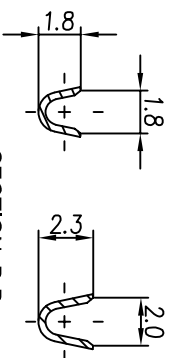

QUANTITY	PART NUMBER	DESCRIPTION	ITEM

MATERIALS LIST

UNLESS OTHERWISE SPECIFIED	SIGNATURES	DATE	ECO-MATE SOCKET CONTACT, STAMPED, 22-20AWG, SIZE 16
1) All dimensions are in millimeters. 2) Tolerances are as follows: 1 PL DEC 2010 Fractions 1/16" 3 PL DEC 2010 Angles 1°	Flan	Jul-16-18	<p><b>Amphenol</b></p> <p>Sine Systems - <a href="http://www.amphenol-sine.com">www.amphenol-sine.com</a> 44724 Morley Drive Clinton Township, MI 48036</p>
3) Note reference = $\Delta$	Tommy	Jul-16-18	

PROCESS SPECIFICATIONS	CUSTOMER	SIZE	TYPE	SCALE	SHEET	OF
<p>1) All dimensions are in millimeters. 2) Tolerances are as follows: 1 PL DEC 2010 Fractions 1/16" 3 PL DEC 2010 Angles 1°</p> <p>3) Note reference = <math>\Delta</math></p>	Tommy	B	C-	NONE	1	1

# Mouser Electronics

Authorized Distributor

Click to View Pricing, Inventory, Delivery & Lifecycle Information:

[Amphenol:](#)

[SS20M2G15](#)