

LEGEND  = KEY PRODUCT CHARACTERISTICS

REVISION HISTORY

REV	DESCRIPTION	DATE	BY	ECN
0	FIRST ISSUE	09/06/21	MH	----

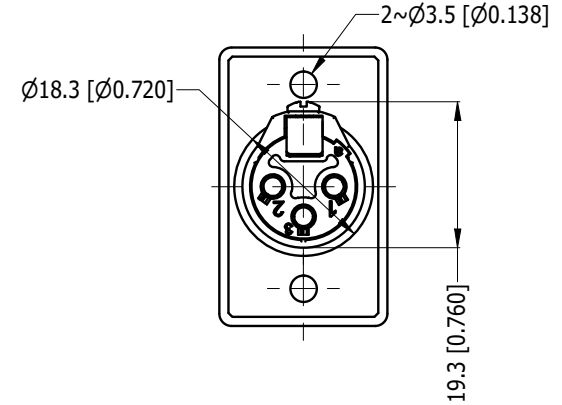
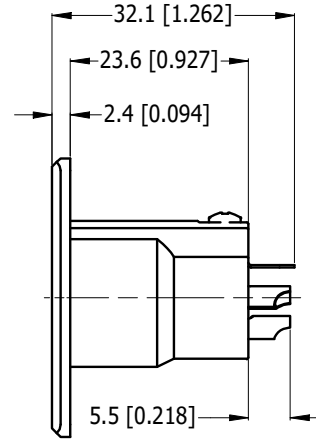
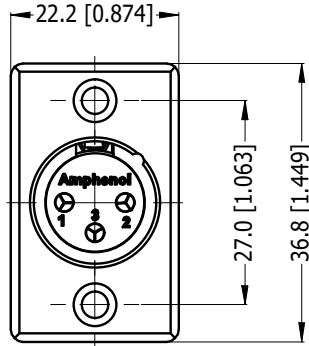
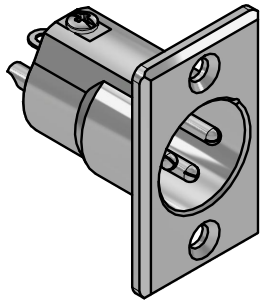

3D VIEWS

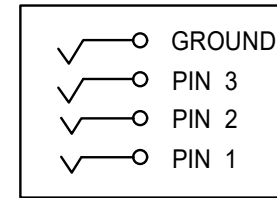
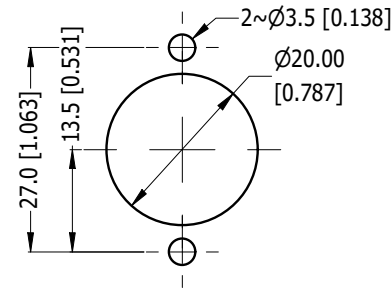
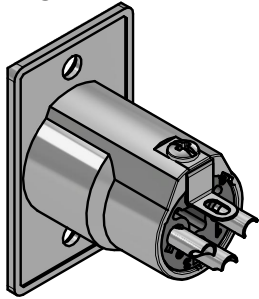

NOTES: ADD "BULK" TO THE PN FOR BULK PACKING, FOR EXAMPLE - AC3MPNZ BULK

RECOMMENDED PANEL CUT OUT

SCHEMATIC CHART

PART NUMBER	SHELL FINISH	STAMPED CONTACT FINISH
AC3MPNZ	NICKEL PLATED	SILVER PLATED
AC3MPNZB	MATT BLACK COATING	SILVER PLATED
AC3MPNZ-AU	NICKEL PLATED	GOLD PLATED
AC3MPNZB-AU	MATT BLACK COATING	GOLD PLATED

UNLESS OTHERWISE SPECIFIED TOLERANCE TO BE	
LINEAR	ANGULAR
X ± 0.5	X' ± 1
X.X ± 0.2	X.X' ± 30'
X.XX ± 0.1	X.XX" ± 15'

THIS DOCUMENT IS THE PROPERTY OF AMPHENOL AUSTRALIA PTY. LTD. NO PART THEREOF MAY BE REPRODUCED AND USED WITHOUT THE PRIOR WRITTEN CONSENT OF THE OWNER			
MATERIAL: SEE COMPONENT	DRN: M.H	DATE: 09/06/21	TITLE: AC3MPNZ PANEL MOUNT CUSTOMER DWG
DO NOT SCALE	CKD: M.H	DATE: 09/06/21	PART No. SEE TABLE
FINISH: SEE TABLE	APP'D: P.M	DATE: 09/06/21	DRAWING No. 55011453-000-1
DIMENSIONS IN MILLIMETRES	SCALE: 1:1	SIZE: A4	SHEET 2/2

Amphenol Amphenol Australia Pty.Ltd,
22 Industry Boulevard, Carrum Downs, VIC 3201



Mouser Electronics

Authorized Distributor

Click to View Pricing, Inventory, Delivery & Lifecycle Information:

[Amphenol:](#)

[AC3MPNZ](#)