

# MIL-PRF-24758-6 Straight Conduit to Tapered Pipe Thread Fitting

A

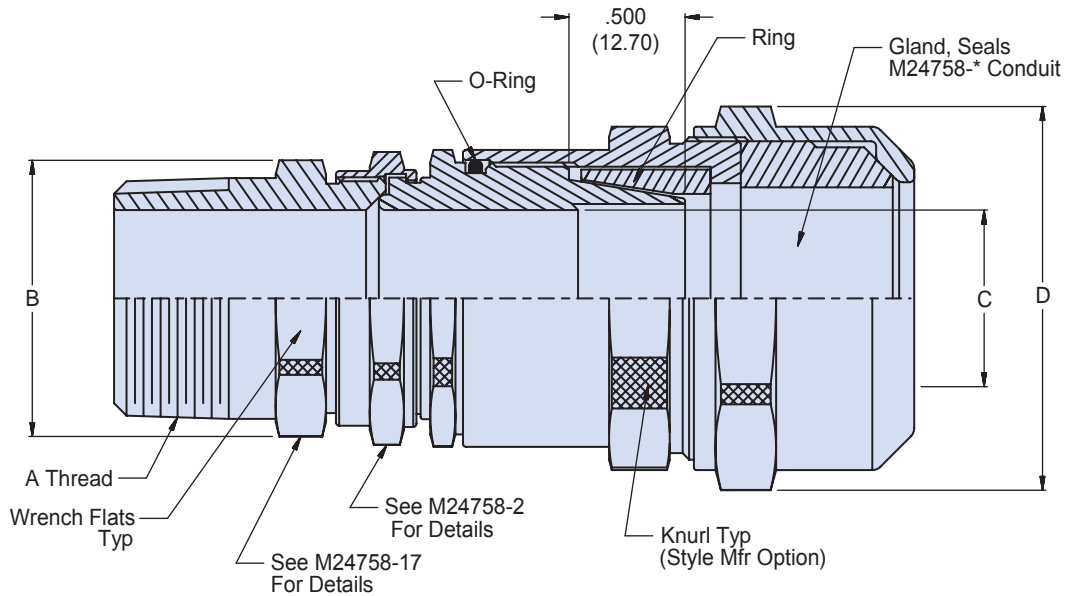
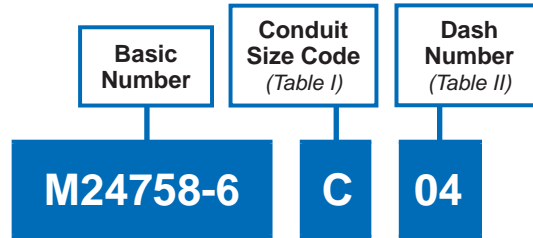

## APPLICATION NOTES

1. Assembly identified with manufacturer's code identification number (Glenair, part number and classification code 490).
2. The function of the M24758-6 fitting is to terminate M24758-\* flexible shielding conduit to a reusable fitting having an external tapered pipe thread.
3. See M24758-2 for recommended torque values.
4. Material / Finish:  
Adapter, nuts, sleeve & ring - 316L SST/Electroless nickel, matte finish.  
O-Ring and gland - Silicone rubber / NA.
5. Metric dimensions (mm) are indicated in parentheses.

# MIL-PRF-24758-6 Straight Conduit to Tapered Pipe Thread Fitting



MIL-PRF  
24758A

A

CONDUIT SIZE CODE	C DIA MIN	D DIA MIN
A	.245 (6.2)	1.140 (29.0)
B	.495 (12.6)	1.460 (37.1)
C	.745 (18.9)	1.780 (45.2)
D	.995 (25.3)	2.030 (51.6)
E	1.245 (31.6)	2.280 (57.9)
F	1.495 (38.0)	2.530 (64.3)
G	1.995 (50.7)	3.140 (79.8)
H	2.495 (63.4)	3.650 (92.7)
J	.370 (9.4)	1.340 (34.0)
K	.620 (15.7)	1.650 (41.9)
L	2.995 (76.1)	4.150 (105.4)

DASH NUMBER	A EXTERNAL TAPER PIPE THREAD	B DIA MAX
1	.250-18 NPT	1.000 (25.40)
2	.375-18 NPT	1.130 (28.70)
3	.500-14 NPT	1.250 (31.75)
4	.750-14 NPT	1.500 (38.10)
5	1.000-11.5 NPT	1.750 (44.45)
6	1.250-11.5 NPT	2.130 (54.10)
7	1.500-11.5 NPT	2.380 (60.45)
8	2.000-11.5 NPT	2.880 (73.15)
9	2.500-8 NPT	3.380 (85.85)
10	3.000-8 NPT	4.130 (104.90)

CONDUIT SIZE CODE	± 5 Inch lbs.	
	A THREAD	SLEEVE
A	40	120
B	45	140
C	50	150
D	80	170
E	80	170
F	80	170
G	80	170
H	80	170
J	45	120
K	50	140
L	80	170

# Mouser Electronics

Authorized Distributor

Click to View Pricing, Inventory, Delivery & Lifecycle Information:

[Glenair:](#)

[M24758-6D05](#) [M24758-6C02](#) [M24758-6F07](#) [M24758-6B04](#) [M24758-6B05](#) [M24758-6E05](#) [M24758-6C05](#) [M24758-6B06](#) [M24758-6D06](#) [M24758-6F06](#) [M24758-6E07](#) [M24758-6C03](#) [M24758-6C06](#)