

A

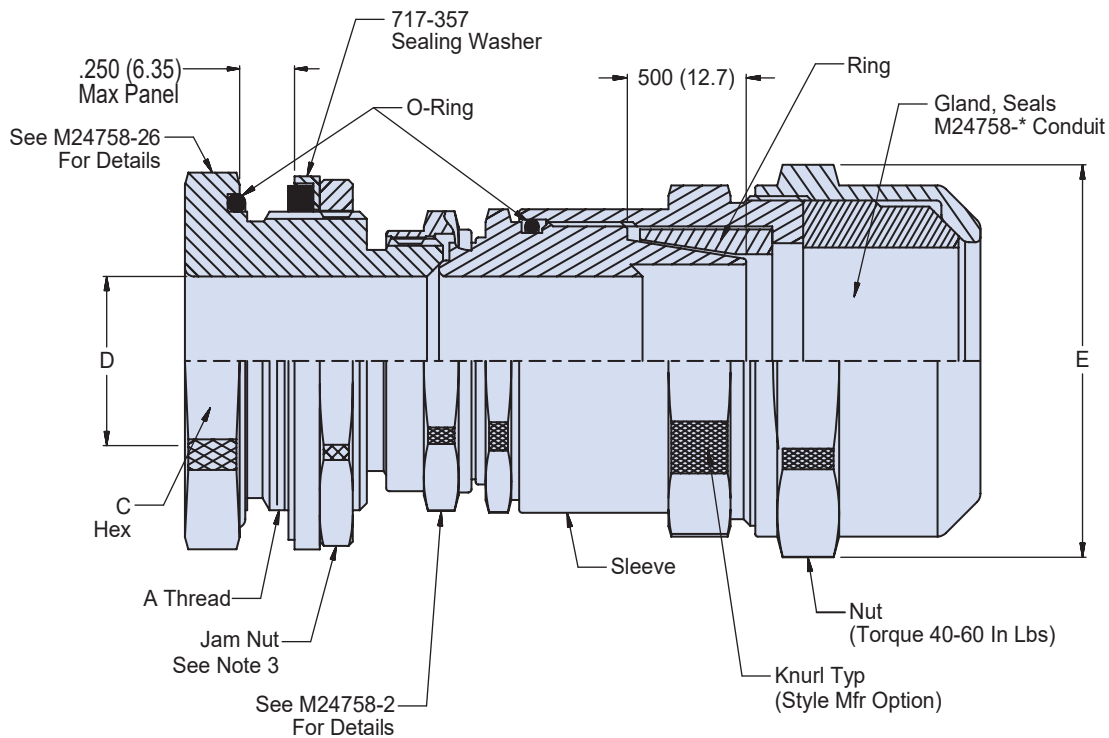
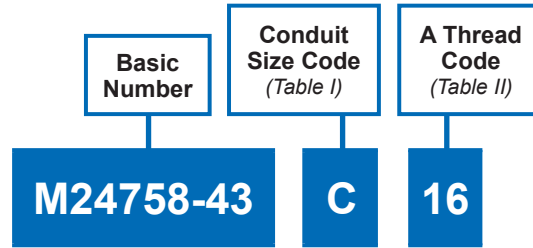

APPLICATION NOTES

1. Assembly identified with manufacturer's code identification number (Glenair, part number and classification code 490).
2. The function of the M24758-43 fitting is to terminate M24758-* flexible shielding conduit with a reusable adapter panel termination.
3. Use Glenair 600-176 jam nut wrench.
4. Material / Finish:
Adapter, nuts, sleeve and ring - 316L SST/Electroless nickel matte finish.
O-Ring and gland - Silicone rubber/NA
Sealing washer - See individual drawing.
5. Metric dimensions (mm) are indicated in parentheses.

MIL-PRF-24758-43 Straight Adapter • Conduit to Panel Termination



MIL-PRF
24758A

A

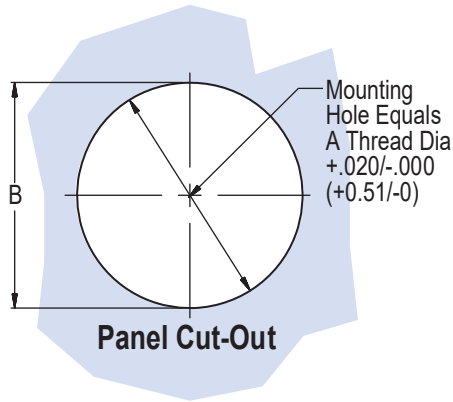

TABLE I: CONDUIT SIZE CODE

CONDUIT SIZE CODE	D MIN DIA	E MAX DIA
A	.245 (6.22)	1.18 (29.97)
B	.495 (12.57)	1.45 (36.83)
C	.745 (18.92)	1.79 (45.47)
D	.995 (24.88)	2.06 (52.32)
E	1.245 (31.62)	2.32 (58.93)
F	1.495 (37.97)	2.59 (65.79)
G	1.995 (50.67)	3.26 (82.80)
H	2.495 (63.37)	3.80 (96.52)
J	.370 (9.40)	1.32 (33.53)
K	.620 (15.75)	1.66 (42.16)
L	2.995 (76.07)	4.34 (110.24)

TABLE II

DASH NO	A CLASS - 2A THREAD	B +.03 (0.8) -0.00	C FLATS	MAX SIZE CODE (TABLE I)		RECOMMENDED TORQUE VALUES INCH LBS (See Note 3)
				J	B	
20	5/8-24 UNEF	.630 (16.0)	.875 (22.2)	J	B	40 - 50
24	3/4-20 UNEF	.750 (19.1)	1.000 (25.4)	B	K	
28	7/8-20 UNEF	.880 (22.4)	1.125 (28.6)	K	C	50 - 60
32	1-20 UNEF	1.000 (25.4)	1.250 (31.8)	C	-	
36	1 1/8-18 UNEF	1.130 (28.7)	1.375 (34.9)	C	D	80 - 90
40	1 1/4-18 UNEF	1.250 (31.8)	1.500 (38.1)	D	-	
42	1 5/16-18 UNEF	1.310 (33.3)	1.625 (41.3)	D	-	
48	1 1/2-18 UNEF	1.500 (38.1)	1.750 (44.5)	D	E	
56	1 3/4-16 UN	1.750 (55.5)	2.000 (50.8)	E	F	100 - 110
64	2-16 UN	2.000 (50.8)	2.250 (57.15)	F	-	
80	2 1/2-16 UN	2.500 (63.50)	2.750 (69.85)	G	-	150 - 160
96	3-16 UN	3.000 (76.20)	3.250 (82.55)	H	-	
112	3 1/2-16 UN	3.500 (88.90)	3.750 (95.25)	L	-	

Type 1 Type 2

Mouser Electronics

Authorized Distributor

Click to View Pricing, Inventory, Delivery & Lifecycle Information:

[Glenair:](#)

[M24758-43B24](#) [M24758-43B28](#) [M24758-43B32](#) [M24758-43B36](#) [M24758-43C28](#) [M24758-43C32](#) [M24758-43D40](#)
[M24758-43D48](#) [M24758-43D64](#) [M24758-43E48](#) [M24758-43G80](#) [M24758-43J32](#)