

A

Basic
NumberConduit
Size Code
(Table I)

M24758-4

C

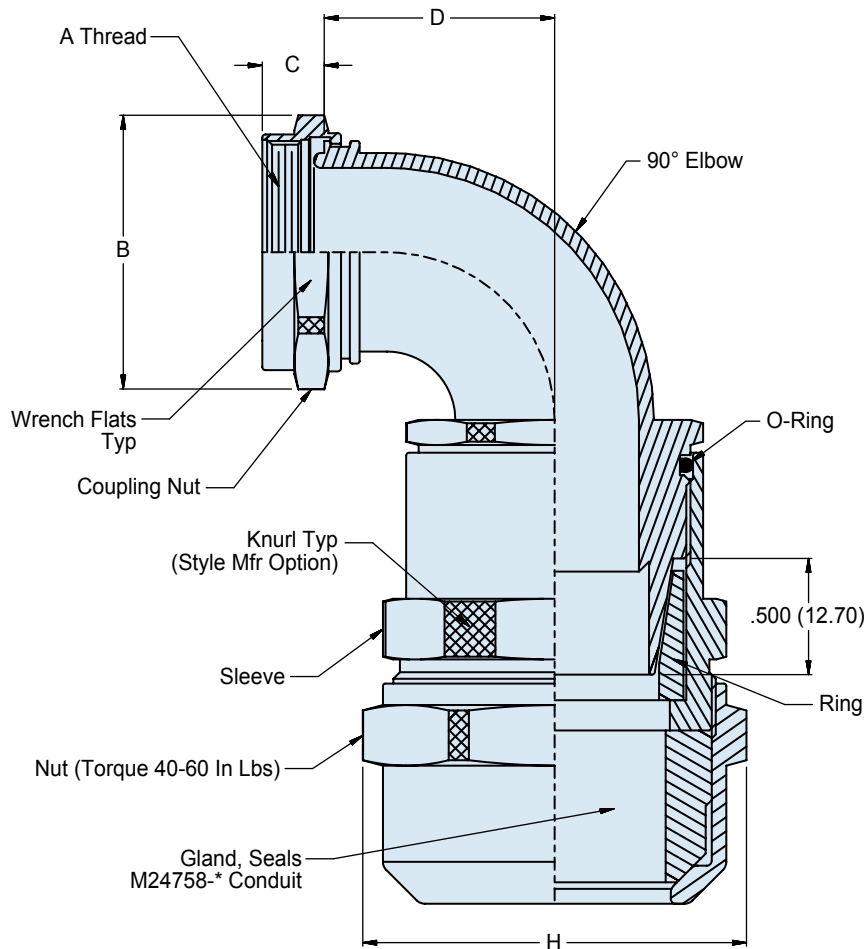

APPLICATION NOTES

1. Assembly identified with manufacturer's code identification number (Glenair, part number and classification code 490).
2. The function of the M24758-4 fitting is to terminate M24758-* flexible shielding conduit and to provide a standard thread for attaching onto M24758-9 through M24758-25 fittings.
3. Material / Finish:
Adapter, nuts, sleeve & ring - 316 / electroless nickel, matte finish.
O-ring and gland - silicone rubber / NA.
4. Metric dimensions (mm) are indicated in parentheses.

TABLE I

CONDUIT SIZE CODE	C CLASS - 2B THREAD	B DIA MAX	C DIM MIN	D DIM Max	H MAX DIA
A	.438-28 UNEF	.88 (22.35)	.205 (5.21)	.81 (20.57)	1.18 (29.97)
B	.688-24 UNEF	1.13 (28.70)	.245 (6.22)	1.12 (28.45)	1.45 (36.83)
C	.938-20 UNEF	1.38 (35.05)	.305 (7.75)	1.47 (37.34)	1.79 (45.47)
D	1.250-18 UNEF	1.69 (42.93)	.365 (9.27)	1.81 (45.97)	2.06 (52.32)
E	1.563-18 UNEF	2.00 (50.80)	.365 (9.27)	2.12 (53.85)	2.32 (58.93)
F	1.875-16 UN	2.31 (58.67)	.425 (10.80)	2.50 (63.50)	2.59 (65.79)
G	2.375-16 UN	2.94 (74.68)	.425 (10.80)	3.12 (79.25)	3.26 (82.80)
H	2.875-16 UN	3.44 (87.38)	.425 (10.80)	3.25 (82.55)	3.80 (96.52)
J	.563-24 UNEF	.940 (23.88)	.245 (6.22)	.93 (23.62)	1.32 (33.53)
K	.813-20 UNEF	1.19 (30.23)	.305 (7.75)	1.25 (31.75)	1.66 (42.16)
L	3.375-16 UN	3.94 (100.08)	.425 (10.80)	4.50 (114.30)	4.34 (110.24)

TABLE II
RECOMMENDED TORQUE

CONDUIT SIZE CODE	± 5 Inch lbs.		
	C THREAD	SLEEVE	Nut
A	50	120	40-60
B	75	140	40-60
C	100	150	40-60
D	120	170	40-60
E	140	170	40-60
F	150	170	40-60
G	170	170	40-60
H	170	170	40-60
J	50	120	40-60
K	75	140	40-60
L	170	170	40-60

Mouser Electronics

Authorized Distributor

Click to View Pricing, Inventory, Delivery & Lifecycle Information:

[Glenair:](#)

[M24758-5B](#) [M24758-5C](#)