

A

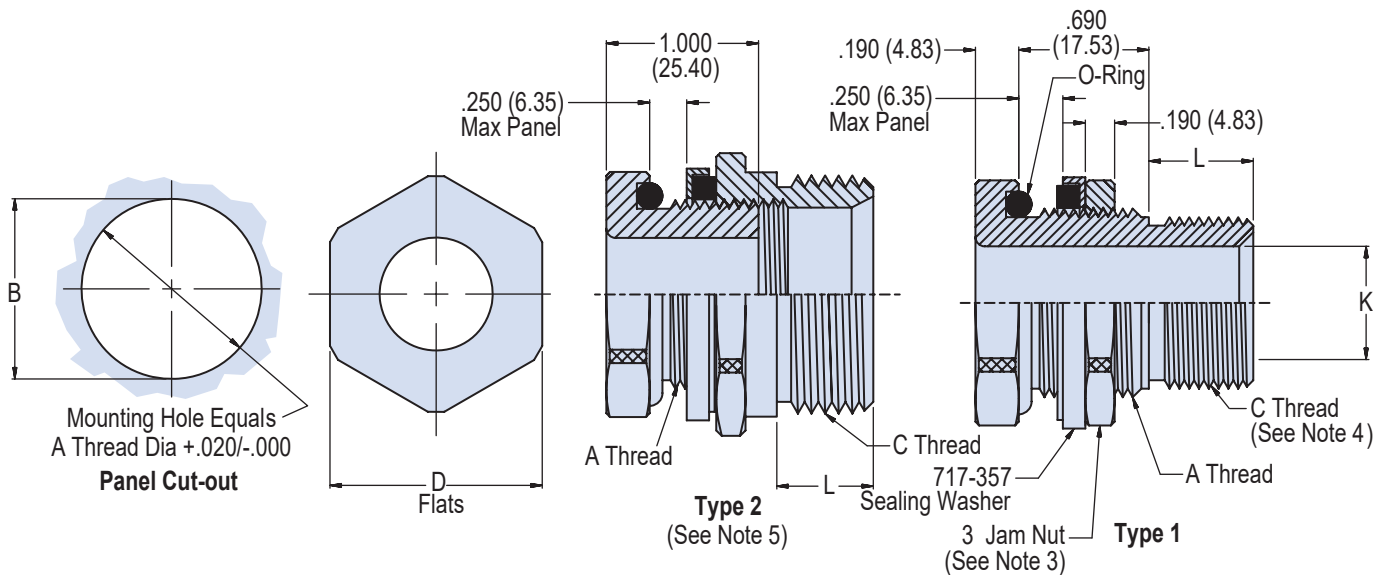
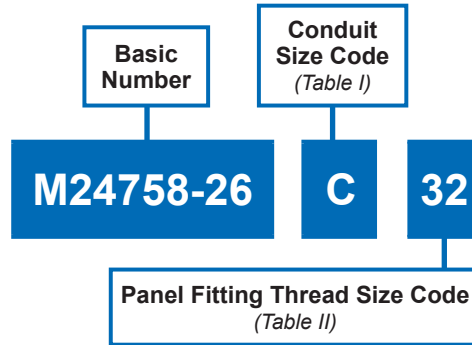

APPLICATION NOTES

- Assembly identified with manufacturer's code identification number (Glenair, part number and classification code 490).
- The M24758-26 adapter provides the capability of terminating a M24758-2, M24758-3 or M24758-4 fitting to a panel.
- Use Glenair 600-176 jam nut wrench.
- See M24758-2 for C thread torque values.
- Type 2 supplied when C thread exceeds A thread (see Table II).
- Metric dimensions (mm) are indicated in parentheses.
- Material / Finish:
 - Adapter, jam nut - 316L stainless steel/electroless nickel, matte finish
 - O-Ring - silicone rubber/N.A.
 - Sealing washer - See individual drawing.

MIL-PRF-24758-26 Adapter for Panel Termination



MIL-PRF
24758A

A

TABLE I

CONDUIT SIZE CODE	C CLASS - 2A THREAD	L + .03 (0.76) - .00	K DIA MIN
A	.438-28 UNEF	.210 (5.33)	.245 (6.22)
B	.688-24 UNEF	.250 (6.35)	.495 (12.57)
C	.938-20 UNEF	.310 (7.87)	.745 (18.92)
D	1.250-18 UNEF	.370 (9.40)	.995 (25.27)
E	1.563-18 UNEF	.370 (9.40)	1.245 (31.62)
F	1.875-16 UN	.430 (10.92)	1.495 (37.97)
G	2.375-16 UN	.430 (10.92)	1.995 (50.67)
H	2.875-16 UN	.430 (10.92)	2.495 (63.37)
J	.563-24 UNEF	.250 (6.35)	.370 (9.40)
K	.813-20 UNEF	.310 (7.87)	.620 (15.75)
L	3.375-16 UN	.430 (10.92)	2.995 (76.07)

TABLE II

DASH NO	A CLASS - 2A THREAD	B + .03 (0.8) - .00	D FLATS	MAX SIZE CODE (TABLE I)		RECOMMENDED TORQUE VALUES INCH LBS (See Note 3)
20	5/8-24 UNEF	.630 (16.0)	.875 (22.2)	J	B	40 - 50
24	3/4-20 UNEF	.750 (19.1)	1.000 (25.4)	B	K	50 - 60
28	7/8-20 UNEF	.880 (22.4)	1.125 (28.6)	K	C	
32	1-20 UNEF	1.000 (25.4)	1.250 (31.8)	C	-	
36	1 1/8-18 UNEF	1.130 (28.7)	1.375 (34.9)	C	D	
40	1 1/4-18 UNEF	1.250 (31.8)	1.500 (38.1)	D	-	80 - 90
42	1 5/16-18 UNEF	1.310 (33.3)	1.625 (41.3)	D	-	
48	1 1/2-18 UNEF	1.500 (38.1)	1.750 (44.5)	D	E	
56	1 3/4-16 UN	1.750 (55.5)	2.000 (50.8)	E	F	100 - 110
64	2-16 UN	2.000 (50.8)	2.250 (57.15)	F	-	
80	2 1/2-16 UN	2.500 (63.50)	2.750 (69.85)	G	-	150 - 160
96	3-16 UN	3.000 (76.20)	3.250 (82.55)	H	-	
112	3 1/2-16 UN	3.500 (88.90)	3.750 (95.25)	L	-	
				Type 1	Type 2	

Mouser Electronics

Authorized Distributor

Click to View Pricing, Inventory, Delivery & Lifecycle Information:

[Glenair:](#)

[M24758-26J28](#)