

| TABLE I |            |                   |       |       |          |  |
|---------|------------|-------------------|-------|-------|----------|--|
| DASH NO | SHELL SIZE | A THREAD CLASS 2B | B DIA | C MAX | D APPROX |  |
| 8       | 8S         | 7/16-28 UNEF      | .562  | .690  | .784     |  |
| 10      | 10S        | 1/2-28 UNEF       | .625  | .690  | .784     |  |
| 11      | 10SL       | 9/16-24 UNEF      | .687  | .690  | .784     |  |
| 12      | 12         | 5/8-24 UNEF       | .750  | .690  | .784     |  |
| 13      | 12S        | 5/8-24 UNEF       | .750  | .690  | .784     |  |
| 14      | 14         | 3/4-20 UNEF       | .875  | .690  | .784     |  |
| 15      | 14S        | 3/4-20 UNEF       | .875  | .690  | .784     |  |
| 16      | 16         | 7/8-20 UNEF       | 1.000 | .846  | .940     |  |
| 17      | 16S        | 7/8-20 UNEF       | 1.000 | .690  | .784     |  |
| 18      | 18         | 1 -20 UNEF        | 1.125 | .846  | .940     |  |
| 20      | 20         | 1 1/8-18 UNEF     | 1.250 | .856  | .950     |  |
| 22      | 22         | 1 1/4-18 UNEF     | 1.375 | .856  | .950     |  |
| 24      | 24         | 1 3/8-18 UNEF     | 1.500 | .800  | .894     |  |
| 28      | 28         | 1 5/8-16 UNEF     | 1.812 | .793  | .887     |  |
| 32      | 32         | 1 7/8-16 UN       | 2.062 | .731  | .825     |  |
| 36      | 36         | 2 1/8-16 UN       | 2.312 | .731  | .825     |  |
| 40      | 40         | 2 3/8-16 UN       | 2.562 | 1.159 | 1.253    |  |

| TABLE II |                   |             |
|----------|-------------------|-------------|
| DASH NO  | E THREAD CLASS 2B | CABLE ENTRY |
| 3        | 1/2-28 UNEF       | .38         |
| 4        | 5/8-24 UNEF       | .50         |
| 6        | 3/4-20 UNEF       | .63         |
| 8        | 7/8-20 UNEF       | .75         |
| 10       | 1 -20 UNEF        | .88         |
| 12       | 1 3/16-18 UNEF    | 1.00        |
| 13       | 1 1/4 -18 UNEF    | 1.06        |
| 16       | 1 7/16-18 UNEF    | 1.25        |
| 20       | 1 3/4 -18 UNS     | 1.50        |
| 24       | 2 -18 UNS         | 1.75        |
| 28       | 2 1/4 -16 UN      | 2.00        |
| 32       | 2 1/4 -16 UN      | 2.25        |
| 40       | 3 -16 UN          | 2.75        |

| TABLE III |                                                    |
|-----------|----------------------------------------------------|
| SYM       | FINISH DESCRIPTION                                 |
| A         | CADMIUM PLATE / BRIGHT DIP                         |
| B         | CADMIUM PLATE / OLIVE DRAB                         |
| E         | GOLD IRIDITE                                       |
| J         | GOLD IRIDITE OVER CADMIUM PLATE OVER NICKEL PLATE  |
| L         | CADMIUM PLATE / BRIGHT DIP OVER ELECTROLESS NICKEL |
| M         | ELECTROLESS NICKEL                                 |
| N         | CADMIUM PLATE / OLIVE DRAB OVER NICKEL PLATE       |
| P         | NICKEL PLATE                                       |
| T         | CADMIUM PLATE OVER NICKEL PLATE                    |
| W         | LEACHED IRIDITE                                    |
| Y         | GOLD IRIDITE OVER CADMIUM PLATE                    |
| Z         | SPECIAL PER PURCHASE ORDER                         |

| REVISIONS |                       |          |          |
|-----------|-----------------------|----------|----------|
| SYM.      | DESCRIPTION           | DATE     | APPROVED |
| J         | REDRAWN PER DCN 09600 | 03/03/92 | T.L.     |

PART NUMBER DEVELOPMENT

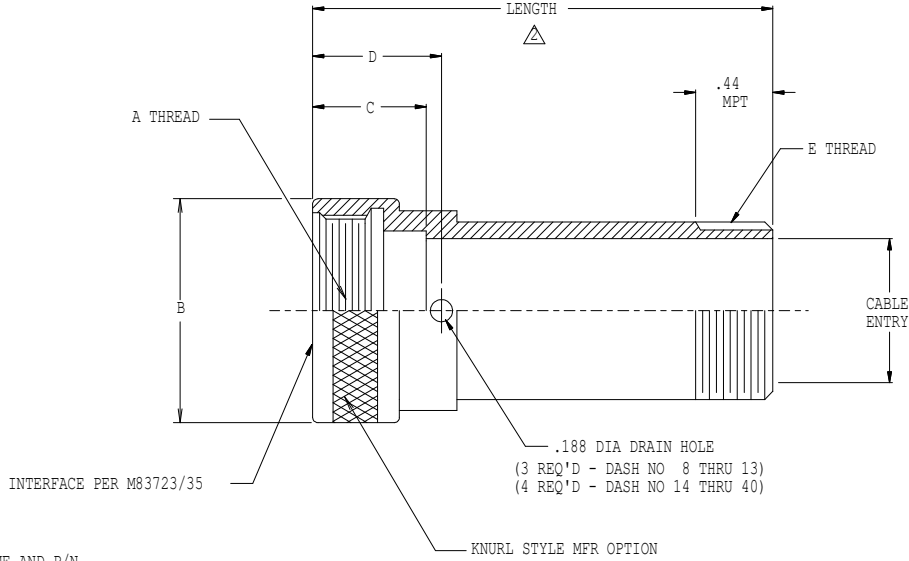
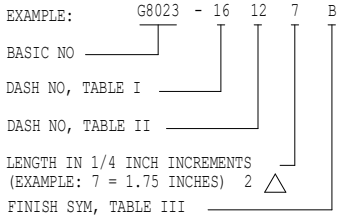

NOTES:

- ASSEMBLY IDENTIFIED WITH MANUFACTURER'S NAME AND P/N, SPACE PERMITTING.
- STANDARD MIN LENGTH: 1.75 INCHES. FOR SHORTER LENGTH, CONSULT FACTORY.
- DISCARD CONNECTOR REAR HARDWARE, WITH THE EXCEPTION OF THE WIRE SEAL FERRULE. WHICH MUST BE RETAINED.
- ADAPTER ACCOMMODATES: BENDIX 90-484, CANON CV, MATRIX M723, AND MI-C-83723, SERIES 2 CONNECTORS.
- MATERIAL/FINISH:  
ADAPTER - AL ALLOY/SEE TABLE III.

|                                                                                                                                               |              |                               |                 |                                                                                                                                                           |              |     |   |
|-----------------------------------------------------------------------------------------------------------------------------------------------|--------------|-------------------------------|-----------------|-----------------------------------------------------------------------------------------------------------------------------------------------------------|--------------|-----|---|
| UNLESS OTHERWISE SPECIFIED<br>DIMENSIONS ARE IN INCHES<br>TOLERANCES:<br>FRACTIONS ± 1/16<br>DECIMALS .XX ± .03<br>.XXX ± .015<br>ANGLES ± 2° | DRAWN        | T. LE                         | 03/03/92        | <b>GLENAIR, INC.</b> <small>EST. 1952</small><br>1211 AIR WAY - GLENDALE - CALIFORNIA 91201<br>ADAPTER TO AN3054, FOR<br>MIL-C-83723, SERIES 2 CONNECTORS |              |     |   |
|                                                                                                                                               | CHECK        | G. BURGE                      | 03/03/92        |                                                                                                                                                           |              |     |   |
|                                                                                                                                               | ENGR         | P. OAKES                      | 03/03/92        |                                                                                                                                                           |              |     |   |
| DO NOT SCALE THIS DRAWING                                                                                                                     | RELEASE DATE | 03/03/92                      | CODE IDENT. NO. | SIZE                                                                                                                                                      | G8023        | REV | J |
| B/F 7198                                                                                                                                      | E/C 360KS    | NON REPARABLE COMMERCIAL ITEM | SCALE N/A       | WEIGHT N/A                                                                                                                                                | SHEET 1 OF 1 |     |   |

# Mouser Electronics

Authorized Distributor

Click to View Pricing, Inventory, Delivery & Lifecycle Information:

[Glenair:](#)

[G8023-2013-9N](#)