

310-017 Composite Shrink Boot Adapter with Direct Coupling Nut

A

CONNECTOR DESIGNATOR:	
A	MIL-DTL-5015, -26482, Series II and -83723 Series I and III
F	MIL-DTL-38999 Series I, II
H	MIL-DTL-38999 Series III and IV
DIRECT COUPLING	

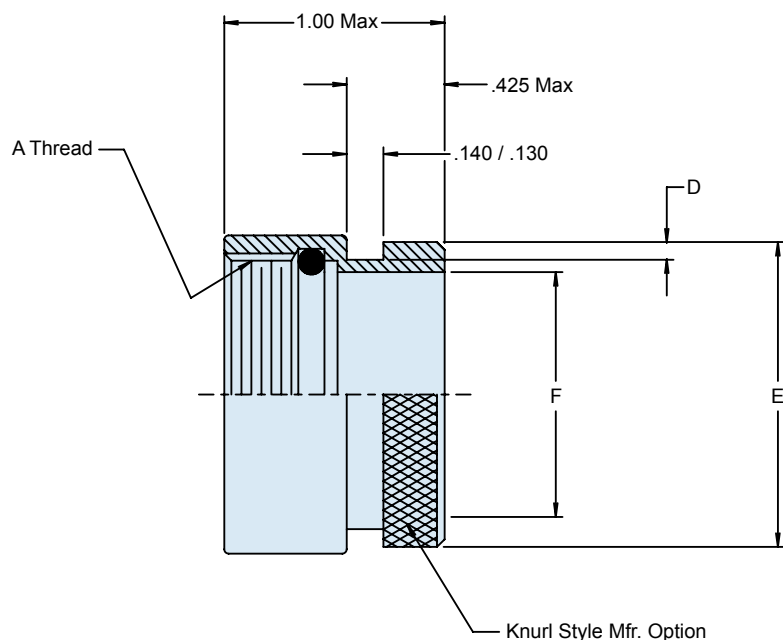
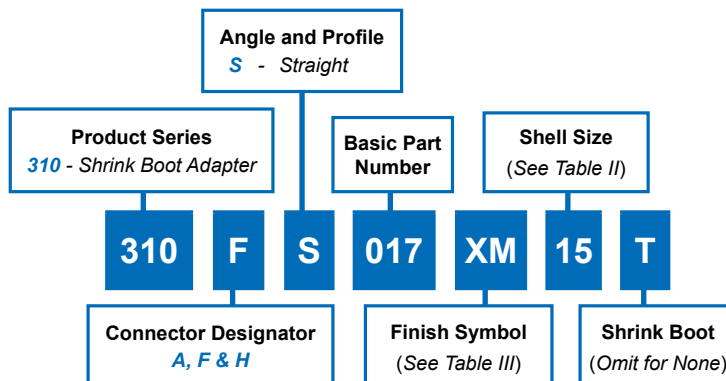

TABLE III: FINISH	
Symbol	Finish Description
XB	No Plating - Black Color (Non-Conductive Finish)
XO	Composite Material—No Plating, Color Black and Brown, Brass Interface Shroud and Adapter—Nickel Plated
XM	2000 Hour Corrosion Resistant Electroless Nickel
XMT	2000 Hour Corrosion Resistant Ni-PTFE, Nickel-Fluorocarbon Polymer. 1000 Hour Grey™
XW	2000 Hour Corrosion Resistant Cadmium/Olive Drab over Electroless Nickel

TABLE II: SHELL SIZE			
Shell Size	D	E	F
	+ .008 - .000	+ .000 - .045	
H			
09	.044 (1.1)	.612 (15.5)	.346 (8.8)
11	.044 (1.1)	.732 (18.6)	.475 (12.1)
13	.044 (1.1)	.857 (21.8)	.589 (15.0)
15	.044 (1.1)	.980 (24.9)	.714 (18.1)
17	.044 (1.1)	1.100 (27.9)	.839 (21.3)
19	.069 (1.8)	1.215 (30.9)	.945 (24.0)
21	.069 (1.8)	1.345 (34.2)	1.070 (27.2)
23	.069 (1.8)	1.465 (37.2)	1.195 (30.4)
25	.069 (1.8)	1.590 (40.4)	1.320 (33.5)

- | NOTES |
|---|
| 1. See Table I in Intro for front-end dimensional details. |
| 2. (Straight) 770-001S**-0 shrink boot supplied with "T" option. For angled shrink boot, contact Glenair engineering. See shrink boot product page for more details. |
| 3. O-Ring will not be supplied with Connector Designator A. |

Mouser Electronics

Authorized Distributor

Click to View Pricing, Inventory, Delivery & Lifecycle Information:

[Glenair:](#)

[310HS017XM11](#)