

805-006 Mighty Mouse Hermetic Receptacles with PC Tails or Solder Cups How to Order Information

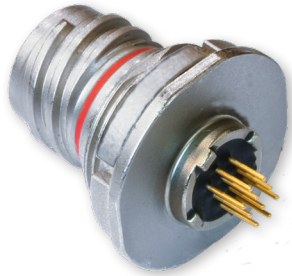

Series 805 Hermetic Receptacles feature 304L stainless steel shells, fused vitreous glass insulator and alloy 52 gold plated contacts. Triple-start ACME thread provides fast mating and cross-threading protection. 1 X 10⁻⁷ cc/second maximum helium leak rate.

Four Shell Styles: jam nut, square flange, solder mount or weld mount.

Solder Cup Contacts or PC Tails
Solder cup contacts accommodate up to size #22 AWG wire. For attachment to flexible or rigid circuits select PC tails.

HOW TO ORDER SERIES 800 HERMETIC RECEPTACLES

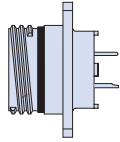
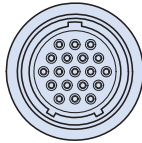
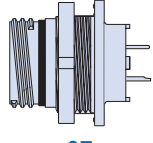
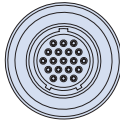
| Sample Part Number | | | | | |
|---------------------------------------|---|--|---------------------------------------|--------------------------------|--|
| 805-006 | -07 | Z1 | 12-26 | C | A |
| Series | Shell Style | Shell Material / Finish | Shell Size- Insert Arrangement | Contact Type | Shell Key Position |
| 805-006 Hermetic Receptacle |  -02 Square Flange | Z1 Stainless Steel / Passivated ZL Stainless Steel / Nickel Plated *Titanium and Inconel® shell materials are available. Consult factory for ordering information. | See Page C-4 for Contact Arrangements | P Pin, Solder Cup | A Position A (Normal) |
| |  -03 Solder Mount | | | C Pin, PC Tail | B Position B |
| |  -07 Jam Nut | | | S Socket, Solder Cup | C Position C |
| |  -13 Weld Mount | | | D Socket, PC Tail | D Position D E Position E F Position F |

Dimensions in Inches (millimeters) are subject to change without notice.



805-006-02 Mighty Mouse

Hermetic Receptacles with PC Tails or Solder Cups

Flange Mount Hermetic Receptacles

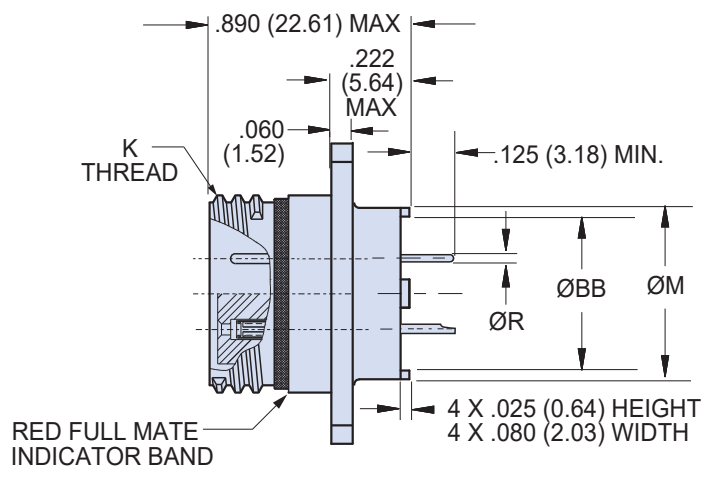
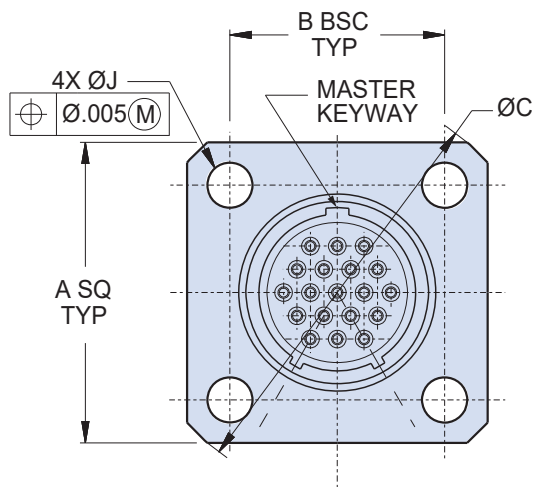

Dimensions

| Shell Size | A SQ | B BSC | BB | Ø C | Ø J Holes | K Threads | Ø M | Ø R Tail Dia. |
|------------|---------------|---------------|---------------|---------------|----------------------------------|----------------------|---------------|---------------------------------|
| 8 | .850 (21.59) | .660 (16.76) | .236 (5.99) | 1.150 (29.21) | .096 (2.44) | .5000-.1P-.3L-TS-2A | .330 (8.38) | #23 .018/.022 (0.46/0.56) |
| 9 | .913 (23.19) | .723 (18.36) | .322 (8.18) | 1.230 (31.24) | | .5625-.1P-.3L-TS-2A | .432 (10.97) | |
| 10 | .975 (24.76) | .785 (19.94) | .386 (9.80) | 1.330 (33.78) | | .6250-.1P-.3L-TS-2A | .493 (12.52) | #20 .024/.028 (0.61/0.71) |
| 11 | 1.039 (26.39) | .848 (21.54) | .442 (11.23) | 1.410 (35.81) | | .6875-.1P-.3L-TS-2A | .553 (14.05) | |
| 12 | 1.099 (27.91) | .909 (23.09) | .513 (13.03) | 1.500 (38.10) | | .7500-.1P-.3L-TS-2A | .620 (15.75) | #16 .060/.064 (1.52/1.63) |
| 13 | 1.163 (29.54) | .973 (24.71) | .554 (14.07) | 1.590 (40.39) | | .8125-.1P-.3L-TS-2A | .661 (16.79) | |
| 15 | 1.288 (32.72) | 1.058 (26.87) | .594 (15.09) | 1.750 (44.45) | .130 .126 (3.30) (3.20) | .9375-.1P-.3L-TS-2A | .703 (17.86) | #12 .092/.096 (2.34/2.44) |
| 18 | 1.475 (37.47) | 1.255 (31.88) | .755 (19.18) | 2.000 (50.80) | | 1.1250-.1P-.3L-TS-2A | .863 (21.92) | |
| 19 | 1.537 (39.04) | 1.327 (33.71) | .805 (20.45) | 2.094 (53.19) | | 1.1875-.1P-.3L-TS-2A | .912 (23.16) | |
| 21 | 1.663 (42.24) | 1.452 (36.88) | .910 (23.11) | 2.270 | | 1.3125-.1P-.3L-TS-2A | 1.017 (25.83) | |
| 23 | 1.787 (45.39) | 1.576 (40.03) | 1.055 (26.80) | 2.440 (61.98) | 1.4375-.1P-.3L-TS-2A | 1.162 (29.51) | | |

Performance Specifications

| | |
|-----------------------|---|
| DWV (VAC Sea Level) | #23 500 V., #20HD 750 V., #12 AND #16 1800 V. |
| Insulation Resistance | 5000 Megohms Minimum |
| Operating Temperature | -55° C. to +150° C. |
| Immersion, Mated | MIL-STD-810 Method 512. One Meter for One Hour. |
| Hermeticity | 1 x 10 ⁻⁷ cc/sec Helium Leak Rate @ 1 Atmosphere Diff. |

Materials And Finishes

| | |
|-----------|-----------------------------|
| Shell | 304L Stainless Steel |
| Insulator | Fused Vitreous Glass |
| Seals | Fluorosilicone Rubber, Blue |
| Contacts | Iron Alloy (Alloy 52) |

Series 805 Key Positions

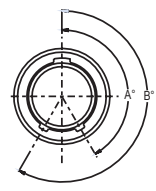

| Key Position | Key Rotation | |
|--------------|--------------|------|
| | A° | B° |
| Normal (A) | 150° | 210° |
| B | 75° | 210° |
| C | 95° | 230° |
| D | 140° | 275° |
| E | 75° | 275° |
| F | 95° | 210° |

Dimensions in Inches (millimeters) are subject to change without notice.

805-006-03 Mighty Mouse Hermetic Receptacles with PC Tails or Solder Cups Solder Mount Receptacles

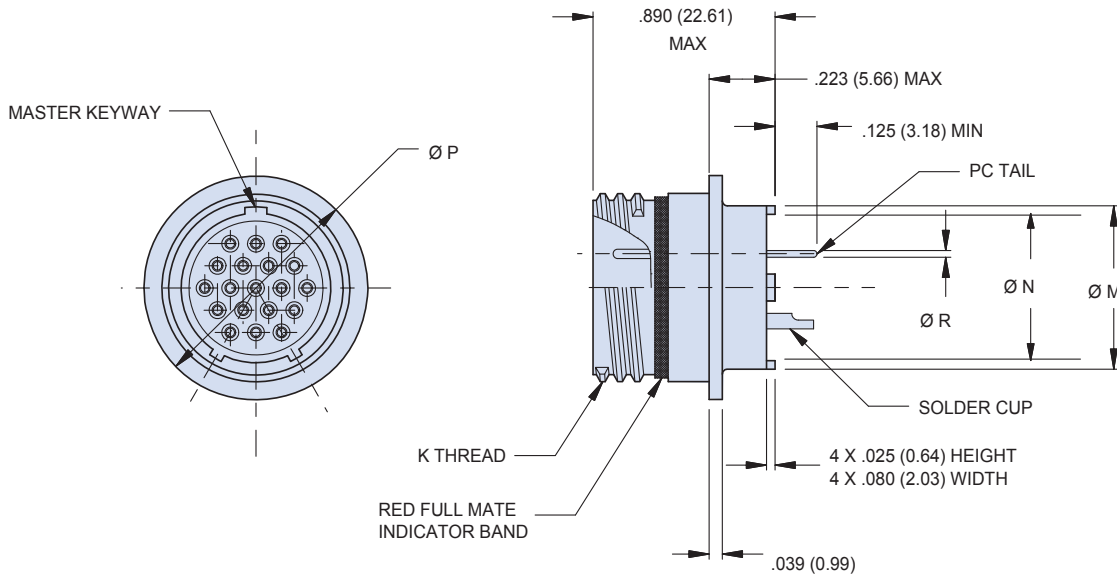

| Dimensions | | | | | |
|------------|---------------|----------------------|---------------|---------------|---------------------------------|
| Shell Size | Ø P | K Thread | M Ø | N Ø | Ø R Tail Dia. |
| 8 | .625 (15.88) | .5000-.1P-.3L-TS-2A | .330 (8.38) | .236 (5.99) | #23 .018/.022 (0.46/0.56) |
| 9 | .688 (17.48) | .5625-.1P-.3L-TS-2A | .432 (10.97) | .322 (8.18) | |
| 10 | .750 (19.05) | .6250-.1P-.3L-TS-2A | .493 (12.52) | .386 (9.80) | #20 .024/.028 (0.61/0.71) |
| 11 | .812 (20.62) | .6875-.1P-.3L-TS-2A | .553 (14.05) | .442 (11.23) | |
| 12 | .875 (22.23) | .7500-.1P-.3L-TS-2A | .620 (15.75) | .513 (13.03) | #16 .060/.064 (1.52/1.63) |
| 13 | .938 (23.83) | .7500-.1P-.3L-TS-2A | .661 (16.79) | .554 (14.07) | |
| 15 | 1.062 (26.97) | .9375-.1P-.3L-TS-2A | .703 (17.86) | .594 (15.09) | #12 .092/.096 (2.34/2.44) |
| 18 | 1.250 (31.75) | 1.1250-.1P-.3L-TS-2A | .863 (21.92) | .755 (19.18) | |
| 19 | 1.312 (33.32) | 1.1875-.1P-.3L-TS-2A | .912 (23.16) | .805 (20.45) | |
| 21 | 1.438 (36.53) | 1.3725-.1P-.3L-TS-2A | 1.017 (25.83) | .910 (23.11) | |
| 23 | 1.562 (39.67) | 1.4375-.1P-.3L-TS-2A | 1.162 (29.51) | 1.055 (26.80) | |

| Series 805 Key Positions | | |
|--------------------------|--------------|------|
| | | |
| Key Position | Key Rotation | |
| | A° | B° |
| Normal (A) | 150° | 210° |
| B | 75° | 210° |
| C | 95° | 230° |
| D | 140° | 275° |
| E | 75° | 275° |
| F | 95° | 210° |

Dimensions in Inches (millimeters) are subject to change without notice.



805-006-07 Mighty Mouse Hermetic Receptacles with PC Tails or Solder Cups Jam-Nut Mount Receptacles

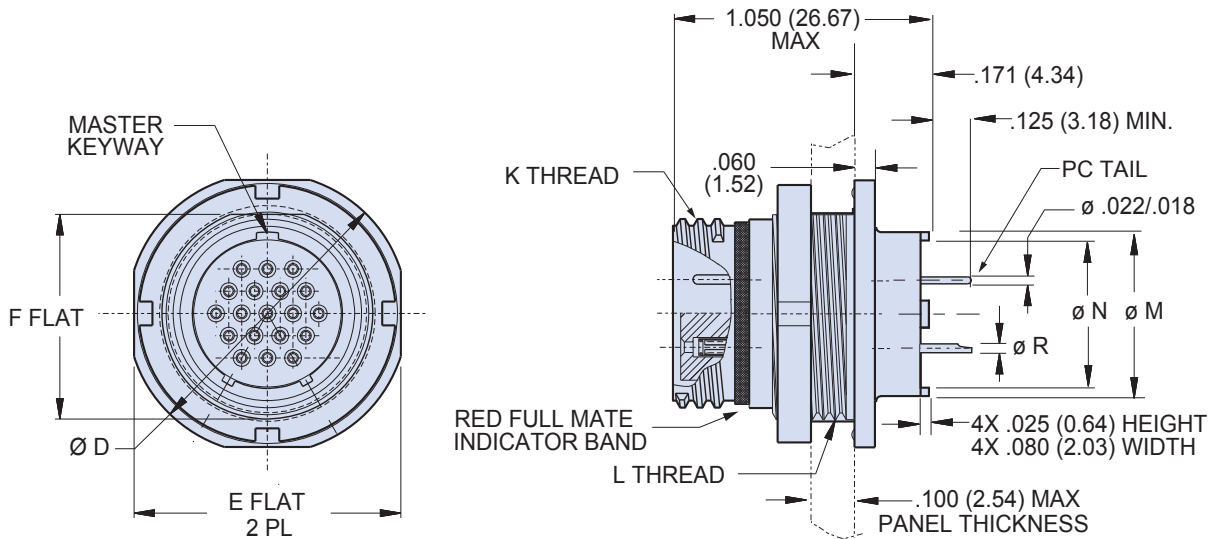

| Dimensions | | | | | | | | |
|------------|---------------|---------------|---------------|---------------|---------------|---------------------|------------------|---------------------------------|
| Shell Size | Ø D | E Flat | F Flat | Ø M | Ø N | K Thread | L Thread | Ø R Tail Dia. |
| 8 | .760 (19.30) | .730 (18.54) | .535 (13.59) | .330 (8.38) | .236 (5.99) | .5000-1P-.3L-TS-2A | .5625-28 UNEF-2A | #23 .018/.022 (0.46/0.56) |
| 9 | .880 (22.35) | .850 (21.59) | .661 (16.79) | .432 (10.97) | .322 (8.18) | .5625-1P-.3L-TS-2A | .6875-28 UN-2A | #20 .024/.028 (0.61/0.71) |
| 10 | .880 (22.35) | .850 (21.59) | .661 (16.79) | .493 (12.52) | .386 (9.80) | .6250-1P-.3L-TS-2A | .6875-28 UN-2A | #16 .060/.064 (1.52/1.63) |
| 11 | .955 (24.26) | .925 (23.50) | .721 (18.31) | .553 (14.05) | .442 (11.23) | .6875-1P-.3L-TS-2A | .7500-28 UN-2A | #12 .092/.096 (2.34/2.44) |
| 12 | 1.060 (26.92) | 1.035 (26.29) | .784 (19.91) | .620 (15.75) | .513 (13.03) | .7500-1P-.3L-TS-2A | .8125-28 UN-2A | |
| 13 | 1.120 (28.45) | 1.090 (27.69) | .843 (21.41) | .661 (16.79) | .554 (14.07) | .8125-1P-.3L-TS-2A | .8750-28 UN-2A | |
| 15 | 1.203 (30.56) | 1.173 (29.79) | .970 (24.64) | .703 (17.86) | .594 (15.09) | .9375-1P-.3L-TS-2A | 1.0000-28 UN-2A | |
| 18 | 1.389 (35.28) | 1.359 (34.52) | 1.147 (29.13) | .863 (21.92) | .755 (19.18) | 1.1250-1P-.3L-TS-2A | 1.1875-28 UN-2A | |
| 19 | 1.450 (36.83) | 1.420 (36.07) | 1.221 (31.01) | .912 (23.16) | .805 (20.45) | 1.1875-1P-.3L-TS-2A | 1.2500-28 UN-2A | |
| 21 | 1.580 (40.13) | 1.550 (39.37) | 1.350 (34.29) | 1.017 (25.83) | .910 (23.11) | 1.3125-1P-.3L-TS-2A | 1.3750-28 UN-2A | |
| 23 | 1.705 (43.31) | 1.675 (42.55) | 1.470 (37.34) | 1.162 (29.51) | 1.055 (26.80) | 1.4375-1P-.3L-TS-2A | 1.5000-25 UN-2A | |

| Panel Cutout For Jam Nut Receptacle | | |
|-------------------------------------|------------------------|---------------------|
| Shell Size | G Flat ±.002 (0.05) | Ø H ±.002 (0.05) |
| 8 | .545 (13.84) | .573 (14.55) |
| 9 | .671 (17.04) | .698 (17.73) |
| 10 | .671 (17.04) | .698 (17.73) |
| 11 | .731 (18.57) | .760 (19.30) |
| 12 | .794 (20.17) | .823 (20.90) |
| 13 | .851 (21.62) | .885 (22.48) |
| 15 | .979 (24.87) | 1.010 (25.65) |
| 18 | 1.157 (29.39) | 1.198 (30.43) |
| 19 | 1.231 (31.27) | 1.260 (32.00) |
| 21 | 1.358 (34.49) | 1.385 (35.18) |
| 23 | 1.479 (37.57) | 1.510 (38.35) |

| Series 805 Key Positions | | |
|--------------------------|--------------|------|
| Key Position | Key Rotation | |
| | A° | B° |
| Normal (A) | 150° | 210° |
| B | 75° | 210° |
| C | 95° | 230° |
| D | 140° | 275° |
| E | 75° | 275° |
| F | 95° | 210° |

Dimensions in Inches (millimeters) are subject to change without notice.

805-006-13

Series 805 Mighty Mouse Triple-Start
Weld Mount, Front Panel Mount Receptacle Dimensions



Series 80
Mighty Mouse

C

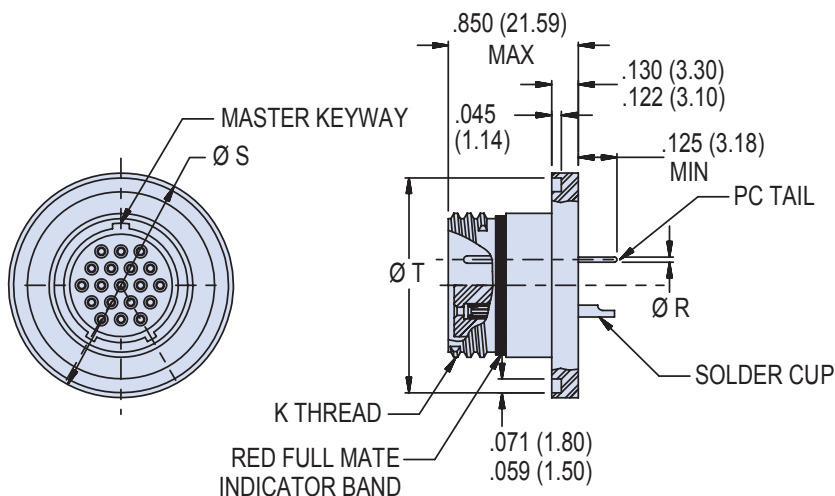

| DIMENSIONS | | | | | | |
|------------|-----------------|---------------|-------|---------------|-------|------------------------------|
| Shell Size | K Thread | Ø S ± .002 | | Ø T ± .006 | | Ø R Tail Dia. |
| | | In. | mm. | In. | mm. | |
| 8 | .5000-1p-3L-TS | .788 | 20.02 | .745 | 18.92 | #23 .018/.022 (0.46/0.56) |
| 9 | .5625-1p-3L-TS | .912 | 23.16 | .869 | 22.07 | |
| 10 | .6250-1p-3L-TS | .975 | 24.77 | .933 | 23.70 | |
| 11 | .6875-1p-3L-TS | 1.038 | 26.37 | .995 | 25.27 | #20 .024/.028 (0.61/0.71) |
| 12 | .7500-1p-3L-TS | 1.100 | 27.94 | 1.057 | 26.85 | |
| 13 | .8125-1p-3L-TS | 1.162 | 29.51 | 1.119 | 28.42 | #16 .060/.064 (1.52/1.63) |
| 15 | .9375-1p-3L-TS | 1.288 | 32.72 | 1.245 | 31.63 | |
| 18 | 1.1250-1p-3L-TS | 1.475 | 37.47 | 1.430 | 36.32 | #12 .092/.096 (2.34/2.44) |
| 19 | 1.1875-1p-3L-TS | 1.540 | 39.12 | 1.495 | 37.97 | |
| 21 | 1.3125-1p-3L-TS | 1.665 | 42.29 | 1.620 | 41.15 | |
| 23 | 1.4375-1p-3L-TS | 1.795 | 45.59 | 1.750 | 44.45 | |

| SERIES 805 KEY POSITIONS | | |
|--------------------------|--------------|------|
| | | |
| Key Position | Key Rotation | |
| | A° | B° |
| Normal (A) | 150° | 210° |
| B | 75° | 210° |
| C | 95° | 230° |
| D | 140° | 275° |
| E | 75° | 275° |
| F | 95° | 210° |

| PANEL CUTOUT FOR WELD MOUNT RECEPTACLE | | | | | |
|--|---------------|------------|-------|--|--|
| Shell Size | Ø U ± .003 | Ø V Min | | | |
| | | In. | mm. | | |
| 8 | .794 | .350 | 8.89 | | |
| 9 | .918 | .455 | 11.56 | | |
| 10 | .981 | .520 | 13.21 | | |
| 11 | 1.044 | .575 | 14.61 | | |
| 12 | 1.106 | .650 | 16.51 | | |
| 13 | 1.168 | .685 | 17.40 | | |
| 15 | 1.294 | .730 | 18.54 | | |
| 18 | 1.481 | .890 | 22.61 | | |
| 19 | 1.546 | .940 | 23.88 | | |
| 21 | 1.671 | 1.040 | 26.42 | | |
| 23 | 1.801 | 1.190 | 30.23 | | |

Dimensions in Inches (millimeters) are subject to change without notice.

Mouser Electronics

Authorized Distributor

Click to View Pricing, Inventory, Delivery & Lifecycle Information:

[Glenair:](#)

[805-006-07Z110-2PA](#)