

**MIL-DTL-38999 Series III Type**

**233-265 Receptacles with removable crimp contacts**

Part Number Development									
Sample Part Number	233-265			-H2	Z1	17-26	P	N	02
Series / Basic Part No.	Series 23 SuperNine Hermetic								
Connector Style	H2 = Box Mount H7 = Jam-Nut Mount								
Finish*	Z1 = CRES, Passivated ZL = CRES, Nickel Finish								
Shell Size/Insert Arrangement*	Per MIL-DTL-38999/MIL-STD-1560								
Contact Style	P = Pin S = Socket								
Polarization*	A, B, C, D, E, N = Normal								
Panel Thickness	01 = .200 inches max 02 = .375 inches max; for jam-nut (H7) version only, omit for box mount (H2) connector								

\*Refer to Section A for complete details, consult factory for additional options  
Modification codes may be added directly to the end of any valid part number

**233-265-H7 JAM NUT RECEPTACLE**

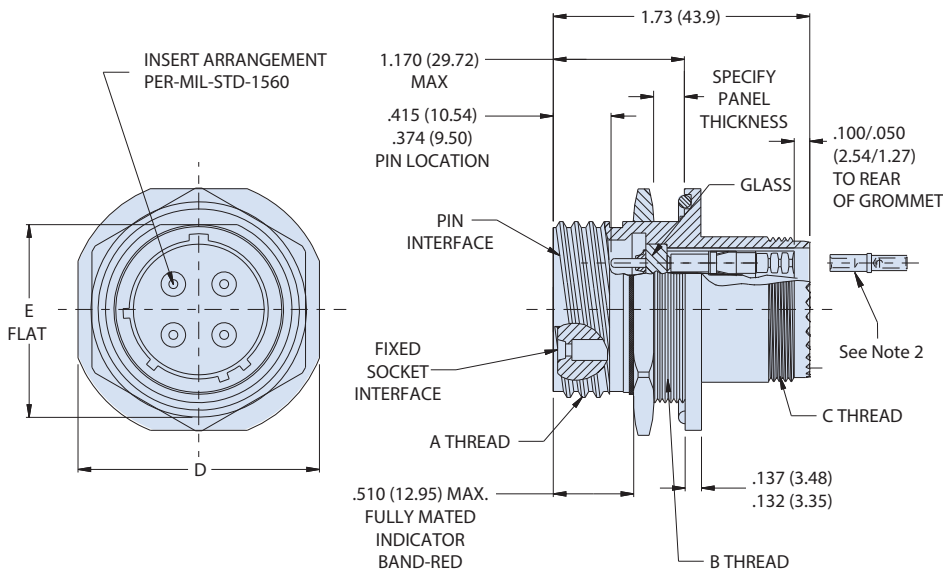

**Material/finish:**

- Shell and jam-nut (H7 only): 300 series CRES/per part number development
- Contacts, pin: alloy 52/gold plated
- Contacts, socket: copper alloy/gold plated
- Insulator: fused vitreous glass/N.A.
- Insulator: high grade rigid dielectric/ N.A.
- Seals: fluorosilicone/N.A

**NOTES**

1. Hermeticity:  $<1 \times 10^{-7}$  ccHe/sec @ 1 ATM, delta pressure
2. Crimp removable socket contacts to conform to M39029/57-359 (size 12) M39029/57-358 (size 16), M39029/57-357 (size 20) and M39029/57-354 (size 22D) contacts required to fully populate rear, plus spares as required by mil-spec, are shipped loose with the connector.

Dimensions								
SHELL SIZE	SHELL SIZE CODE	A - THREAD	B - THREAD	C THREAD	D ±0.016	E +.004 -0.006	PANEL THICKNESS 01 MAX	PANEL THICKNESS 02 MAX
9	A	.6250-.1P3L-TS-2A	M17X1-6g 0.100R	M12X1-6g 0.100R	1.062 (26.97)	0.651 (16.54)	0.200 (5.08)	0.375 (9.52)
11	B	.7500-.1P3L-TS-2A	M20X1-6g 0.100R	M15X1-6g 0.100R	1.252 (31.80)	0.751 (19.08)		
13	C	.8750-.1P3L-TS-2A	M25X1-6g 0.100R	M18X1-6g 0.100R	1.374 (34.90)	0.938 (23.83)		
15	D	1.000-.1P3L-TS-2A	M28X1-6g 0.100R	M22X1-6g 0.100R	1.500 (38.10)	1.062 (26.97)		
17	E	1.1875-.1P3L-TS-2A	M32X1-6g 0.100R	M25X1-6g 0.100R	1.626 (41.30)	1.187 (30.15)		
19	F	1.250-.1P3L-TS-2A	M35X1-6g 0.100R	M28X1-6g 0.100R	1.811 (46.00)	1.312 (33.32)		
21	G	1.375-.1P3L-TS-2A	M38X1-6g 0.100R	M31X1-6g 0.100R	1.937 (49.20)	1.437 (36.50)		
23	H	1.500-.1P3L-TS-2A	M41X1-6g 0.100R	M34X1-6g 0.100R	2.063 (52.40)	1.562 (39.67)		
25	J	1.625-.1P3L-TS-2A	M44X1-6g 0.100R	M37X1-6g 0.100R	2.189 (55.60)	1.687 (42.85)		

## MIL-DTL-38999 Series III Type

### 233-265 Receptacles with removable crimp contacts

HERMETIC CONNECTORS

#### 233-265-H2 BOX MOUNT RECEPTACLE

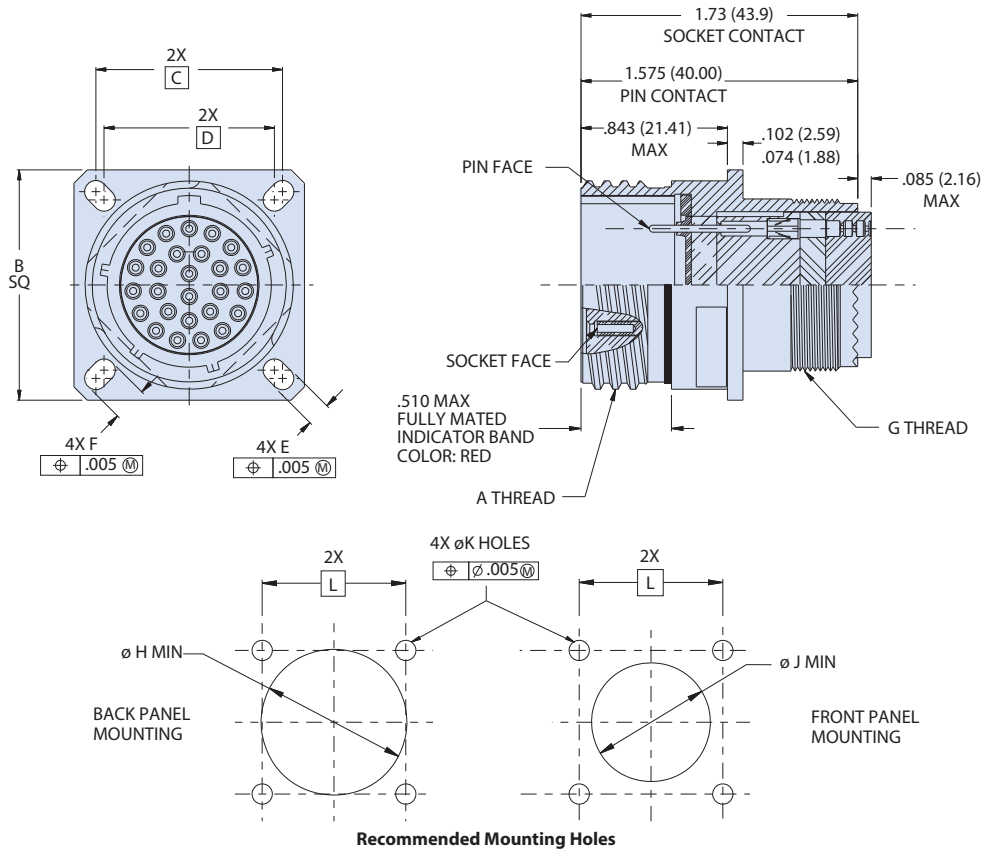

Recommended Mounting Holes

Dimensions												
SHELL SIZE CODE	SHELL SIZE	A THREAD	B SQ	C BSC	D BSC	E	F	G THREAD	ØH MIN	ØJ MIN	ØK HOLES	L BSC
A	9	.6250-.1P-.3L-TS-2A	.949 (24.10) .925 (23.50)	.719 (18.26)	.594 (15.09)	.136 (3.45) .120 (3.05)	.224 (5.69) .208 (5.28)	M12 X 1.0-6g .100R	.656 (16.66)	.516 (13.11)	.133 (3.38) .123 (3.12)	.719 (18.26)
B	11	.7500-.1P-.3L-TS-2A	1.043 (26.49) 1.019 (25.88)	.812 (20.62)	.719 (18.26)		.202 (5.13) .186 (4.72)	M15 X 1.0-6g .100R	.796 (20.22)	.625 (15.88)		.812 (20.62)
C	13	.8750-.1P-.3L-TS-2A	1.138 (28.91) 1.114 (28.30)	.906 (23.01)	.812 (20.62)		.181 (4.60) .165 (4.19)	M18 X 1.0-6g .100R	.922 (23.42)	.750 (19.05)		.906 (23.01)
D	15	1.0000-.1P-.3L-TS-2A	1.232 (31.29) 1.208 (30.68)	.969 (24.61)	.906 (23.01)		M22 X 1.0-6g .100R	1.047 (26.59)	.906 (23.01)	.969 (24.61)		
E	17	1.1875-.1P-.3L-TS-2A	1.323 (33.60) 1.299 (32.99)	1.062 (26.97)	.969 (24.61)		M25 X 1.0-6g .100R	1.219 (30.96)	1.016 (25.81)	1.062 (26.97)		
F	19	1.2500-.1P-.3L-TS-2A	1.449 (36.80) 1.425 (36.20)	1.156 (29.36)	1.062 (26.97)		M28 X 1.0-6g .100R	1.297 (32.94)	1.141 (28.98)	1.156 (29.36)		
G	21	1.3750-.1P-.3L-TS-2A	1.575 (40.00) 1.551 (39.40)	1.250 (31.75)	1.156 (29.36)		M31 X 1.0-6g .100R	1.422 (36.12)	1.266 (32.16)	1.250 (31.75)		
H	23	1.5000-.1P-.3L-TS-2A	1.701 (43.21) 1.677 (42.60)	1.375 (34.92)	1.250 (31.75)	.162 (4.11)	.250 (6.35)	M34 X 1.0-6g .100R	1.547 (39.29)	1.375 (34.92)	.159 (4.04) .149 (3.78)	1.375 (34.92)
J	25	1.6250-.1P-.3L-TS-2A	1.823 (46.30) 1.799 (45.69)	1.500 (38.10)	1.375 (34.92)	.146 (3.71)	.234 (5.94)	M37 X 1.0-6g .100R	1.672 (42.47)	1.484 (37.69)	.155 (3.94) .145 (3.68)	1.500 (38.10)

# Mouser Electronics

Authorized Distributor

Click to View Pricing, Inventory, Delivery & Lifecycle Information:

[Glenair:](#)

[233-265-H7ZL15-35SN-01](#)