

FEATURES

- Small size (1-pole, 2-contacts: 6.8×2.0mm; small mounting area)
- Slim slide switch (1.2mm in height when installed)
- Suitable for SMT reflow soldering
- Tape packaging supporting the auto mounting
- Travel length : 1.5mm
- Horizontal knobs and vertical knobs are available

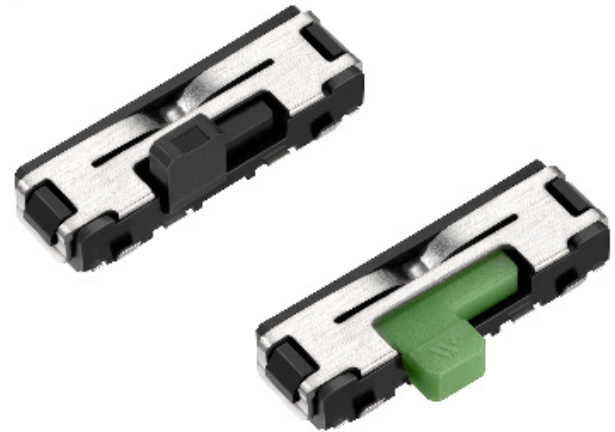

APPLICATIONS

- Smartphones
- Video players
- Remote controllers
- Power switches, hold switches, mold select switches

PART NUMBER CODE

Series	Number of Circuits	Number of Contacts	Operating Force	Orientation	Boss	Packaging
<div style="display: flex; gap: 5px;"> <div style="border: 1px solid black; width: 20px; height: 20px;"></div> <div style="border: 1px solid black; width: 20px; height: 20px;"></div> <div style="border: 1px solid black; width: 20px; height: 20px;"></div> </div>	<div style="border: 1px solid black; width: 20px; height: 20px;"></div>	<div style="border: 1px solid black; width: 20px; height: 20px;"></div>	<div style="border: 1px solid black; width: 20px; height: 20px;"></div>	<div style="border: 1px solid black; width: 20px; height: 20px;"></div>	<div style="border: 1px solid black; width: 20px; height: 20px;"></div>	<div style="border: 1px solid black; width: 20px; height: 20px;"></div>
SSU	1	2	1 (1.5N)	A (horizontal) B (vertical)	R (with)	T (taping)

SPECIFICATIONS

Switch Type	SPDT, SP3T	Slide
Electrical Characteristics	Rating (Resistive Load)	DC 4V, 0.3 A
	Contact Resistance	1Ω or less
	Insulation Resistance	10MΩ or more
	Withstand Voltage	1 minute at AC 100V
Mechanical Characteristics	Operating Force	2 contacts type: 1.5 ± 1.0N
Life		10,000 cycles

TYPE

Model Name	Model No.	Number of Poles	Number of Contacts	Travel	Knob Direction	Earth Terminal	Pcs/Reel
SSU-121ART	R 667016	1	2	1.5mm	Horizontal	Without	5,000
SSU-121BRT	R 667053	1	2	1.5mm	Vertical	Without	3,000

DIMENSIONS

SSU-121ART

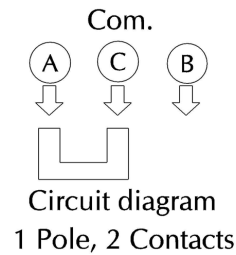
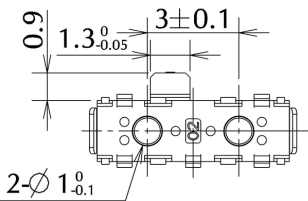
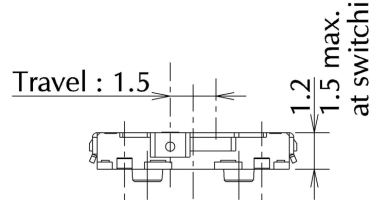
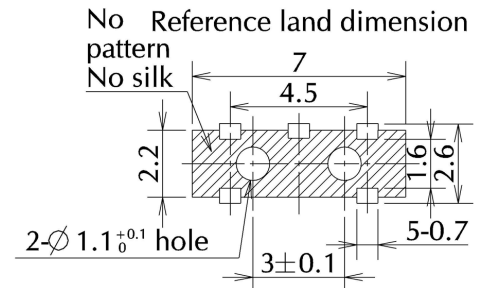
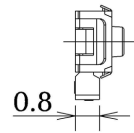
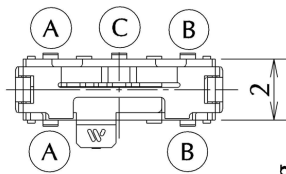
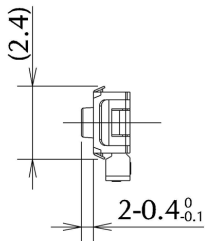
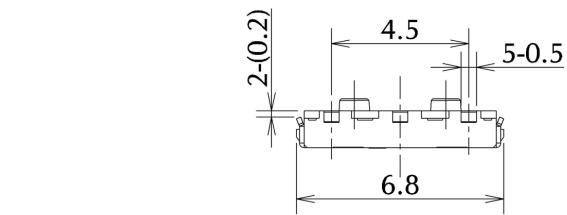

SSU SERIES

H = 1.2mm Slide Switch

MITSUMI

TACTILE SWITCHES

SLIDE SWITCHES

SWITCH SHEETS

SWITCH KITS

DIMENSIONS

SSU-121BRT

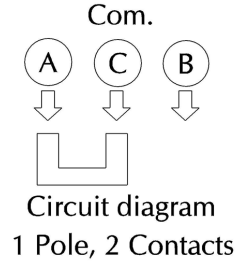
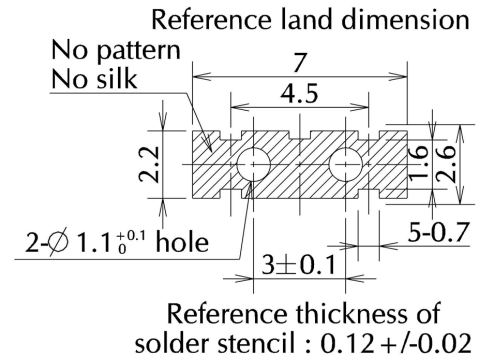
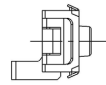
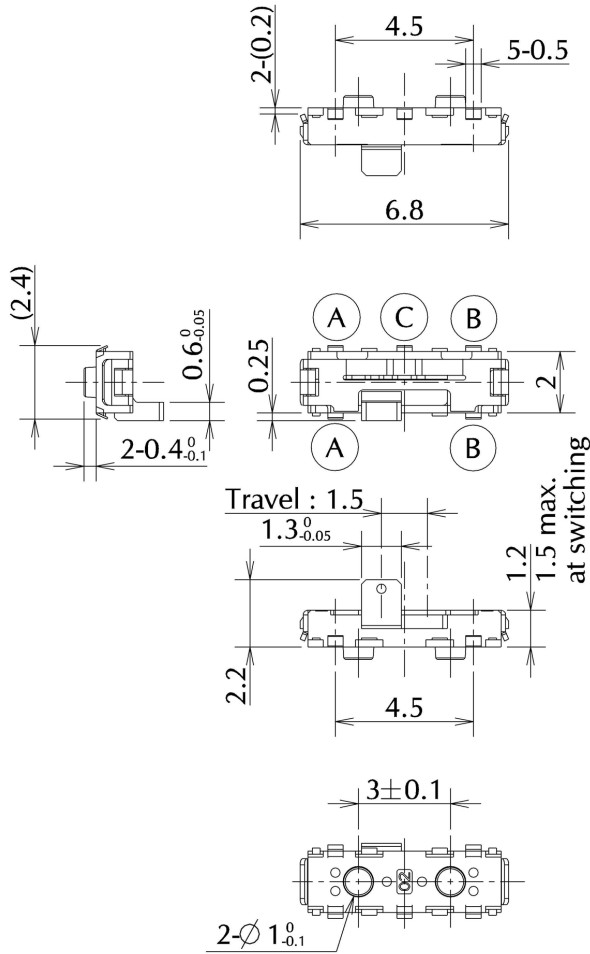

Mouser Electronics

Authorized Distributor

Click to View Pricing, Inventory, Delivery & Lifecycle Information:

[MinebeaMitsumi:](#)

[SSU-121ART](#) [SSU-121BRT](#)