

TW3882



Multi-Constellation Dual-Band Antenna

Frequency Coverage: GPS L1, L2 | GALILEO E1, E5b | BEIDOU B1, B2b | GLONASS G1, G2, G3

The TW3882 employs Calian's patented Accutenna® technology providing dual-band GPS-L1/L2, GLONASS-G1/G2 + BeiDou B1/B2b + Galileo E1 coverage and is especially designed for precision dual frequency positioning.

The TW3882 features a precision tuned, circular dual-feed, stacked patch element. The signals from the two orthogonal feeds are combined in a hybrid combiner, amplified in a wideband LNA, then band-split for narrow filtering in each band and further amplified prior to recombination at the output.

The TW3882 has a pre-filter which increases the antenna's immunity to high amplitude signals, such as LTW and other cellular signals. The TW3882 offers excellent axial ratio and a tightly grouped phase centre variation.

The TW3882 covers GPS L2 (1227.6MHz), GLONASS G2 (1248MHz centre), GPS-L1/WAAS/EGNOS/MSAS (1575.42 MHz), GLONASS-G1 (1602 MHz, centre), BeiDou B1/B2 (1575 and 1207 MHz) and Galileo E1 (1561 and 1589 MHz).

The TW3882 is housed in a through-hole mount, weatherproof enclosure for permanent installations. L Bracket or Pipe Mount (part numbers 23-0040-0, 23-0065-0 respectively) are available for non-rooftop installation. A 100 mm ground plane is provided optimal performance. This product is also available in an OEM format (TW3887).



Applications

- Precision GPS position
- Dual-frequency RTK receivers
- Mission Critical GPS Timing
- Law enforcement and public safety
- Network timing & synchronization

Features

- Very low noise preamp (< 2.5 dB typ.)
- Low axial ratio (< 2.0 dB typ.)
- Tight phase centre variation
- High-gain LNA (35 dB typ.)
- Low current (24 mA typ.)
- ESD circuit protection (15 kV)
- Invariant performance from 2.5 to 16 VDC

Benefits

- Excellent multipath rejection
- Increased system accuracy
- Excellent signal-to-noise ratio
- CE RED, RoHS, and REACH compliant
- EN45545-2, EN50121, EN50155, and EN61373 compliant

About Calian: With global headquarters and manufacturing in Ottawa, Canada, Calian is a leading manufacturer of high-precision antennas and components for Global Navigation Satellite System (GNSS) applications. Calian's mission is to support the needs of a new generation of positioning systems by delivering unprecedented antenna precision at competitive prices. Learn more at www.calian.com

Revision: 202407

Contact us:
info@tallysman.com
T: +1 613 591-3131

Multi-Constellation Dual-Band Antenna

Frequency Coverage: GPS L1, L2 | GALILEO E1, E5b | BEIDOU B1, B2b | GLONASS G1, G2, G3

Antenna - Measured with a 100 mm ground plane

Technology Dual-feed Stacked RHCP ceramic patch

		Gain	Axial Ratio
		dBic typ. at Zenith	dB at Zenith
GNSS			
GPS / QZSS	L1	4.5	≤ 1.0
	L2	4.0	≤ 1.5
	L5	-	-
GLONASS	G1	4.0	≤ 1.0
	G2	3.0	≤ 1.5
	G3	2.8	≤ 1.5
Galileo	E1	4.0	≤ 1.0
	E5A	-	-
	E5B	2.8	≤ 1.5
	E6	-	-
BeiDou	B1	4.0	≤ 1.0
	B2b	2.8	≤ 1.5
	B2a	-	-
	B3	-	-
IRNSS / NavIC	L5	-	-
QZSS	L6	-	-
L-Band Services (1539 MHz - 1559 MHz)	-	-	-
Satellite Communications			
Iridium	-	-	-
Globalstar	-	-	-
Other			
Axial Ratio at 10°	-	Efficiency	-
PCV Φ > 15°	± 10 mm	PCO	-

Mechanicals

Size	66.5 mm (dia.) x 21 mm (h.)
Weight	185 g
Radome	LEXAN™ EXL9330, Base: Zamac Metal
Mount	Through-hole (100 mm ground plane provided)
Available Connectors	Please refer to ordering guide

Environmental

Operating Temperature	-40 °C to +85 °C
Storage Temperature	-55 °C to +95 °C
Vibration	MIL-STD-810-E - Test Method 514.5
Shock	MIL-STD-810-G - Test Method 516.6
Salt Fog	MIL-STD-810-F - Test Method 509.5
Other Tests	Hail, Humidity, Dust, Rain, Sand, Solar
IP Rating	IP69K
Compliance	IPC-A-610, FCC, CE RED, RoHS, REACH

Warranty

Parts and Labour	3-year standard warranty
------------------	--------------------------

Low Noise Amplifier (LNA) - Measured at 3V and 25°C

Frequency Bandwidth	Out of Band Rejection
Lower Band	1191 - 1255 MHz
	≥ 40 dB @ ≤ 1150 MHz ≥ 20 dB @ ≤ 1130 MHz ≥ 50 dB @ ≥ 1350 MHz
L-Band Corr.	-
Upper Band	1559 - 1606 MHz
	≥ 40 dB @ ≤ 1450 MHz ≥ 30 dB @ ≥ 1520 MHz ≥ 35 dB @ ≥ 1650 MHz

Architecture	Pre-filtered
Gain	35 dB typ., 32 dB min.
Noise Figure	2.5 dB typ.
VSWR	< 1.5:1 typ., 1.8:1 max.
Supply Voltage Range	2.5 to 16 VDC nominal, up to 50mV p-p ripple
Supply Current	24 mA typ., 25 mA max. at 75 °C.
ESD Circuit Protection	15 kV air discharge
P 1dB Output	-
Group Delay	-

Mechanical Diagram - Units in 'mm' or 'inches' where specified

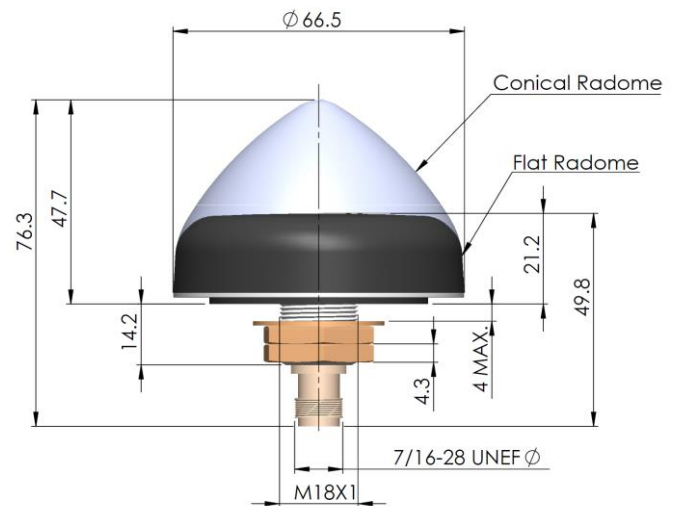

Ordering Information

Part Number **33-3882-xx-yy-zzzz**

Where xx = connector type, yy = shape and colour of radome and zzzz = cable length in mm (where applicable)

Please refer to our **Ordering Guide** to review available radomes and connectors at: <https://www.tallysman.com/resource/tallysman-ordering-guide/>

Mouser Electronics

Authorized Distributor

Click to View Pricing, Inventory, Delivery & Lifecycle Information:

[Calian:](#)

[33-3882-01-00](#)