

Low-Power 1-ch ADC with AAA and Audio Buffer**1. General Description**

The AK5707 is a low power 16-bit monaural ADC featuring the Acoustic Activity Analyzer (AAA), which may be configured by the user to detect specific types of acoustic events. The AK5707 can extend the battery life of connected products by allowing the system SoC to sleep until user-defined qualified audio activity occurs. The AK5707 consumes only 34 μA while the AAA listens for the target sound to occur. Once qualifying audio activity has been detected, the integrated audio buffer begins recording and a wakeup interrupt is sent to the system SoC. The SoC may then read the AK5707's audio buffer and further analyze the contents without having missed audio activity that occurred during boot. The AK5707's AAA feature is well-suited for battery-operated smart security devices that listen for sounds such as glass breaking, intercom ring tones, or specific alarm patterns. Additionally, the AK5707's ADC, which may be powered on and off independently of the AAA, consumes only 200 μA during operation; the efficiency of the ADC makes it equally well-suited for products such as voice-triggered wearable devices, which may require constant audio data capture to the integrated buffer.

2. Features

1. **Acoustic Activity Analyzer (AAA)**
 - **Power Supply Current**
 - High Accuracy Mode (All filters on): 34 μA
 - External Trigger Mode: 8 μA
 - **Two Interrupt Outputs**
2. **Built-in Audio Buffer: 32 kB for up to 1 sec of recording**
3. **Audio Capture**
 - **1-Channel Low-Power 16-bit ADC**
 - S/N, DR: 96 dB
 - **Single-ended Inputs or Full-differential Inputs**
 - **MIC Amplifier Gain: +24 dB to 0 dB, 3 dB step**
 - **Selectable Digital Filter (Low-latency Sharp Roll-off or Voice)**
 - **1-output MEMS Microphone Power Supply**
 - AVDD (1.8 V) / Internal LDO (1.22 V) Selectable
4. **External Trigger Input for AAA / ADC Power-up**
5. **Digital Audio Interface**
 - **Slave Mode**
 - **Sampling Frequency**
 - 8 kHz to 48 kHz
 - **Interface Format**
 - 16-bit I²S / MSB justified (Serial audio interface)
 - PDM (Digital mic interface [64fs / 32fs / 48fs / 24fs], Direct interface [64fs])
 - 16-bit I²C-bus / SPI (Audio buffer access)
6. **Built-in PLL**
7. **Power-on Reset Circuit**
8. **Control I/F: I²C-bus (400 kHz) / SPI (13 MHz)**
9. **Operation Temperature Range: Ta = -40 to 85 °C**
10. **Power Supply:**
 - AVDD (ADC, MIC, PLL, LDO): 1.7 to 1.9 V
 - TVDD (Host & Audio I/F): 1.65 to 3.6 V
11. **Package: 16-pin CSP (1.5173 x 1.5677 mm, 0.4mm pitch)**

3. Block Diagram

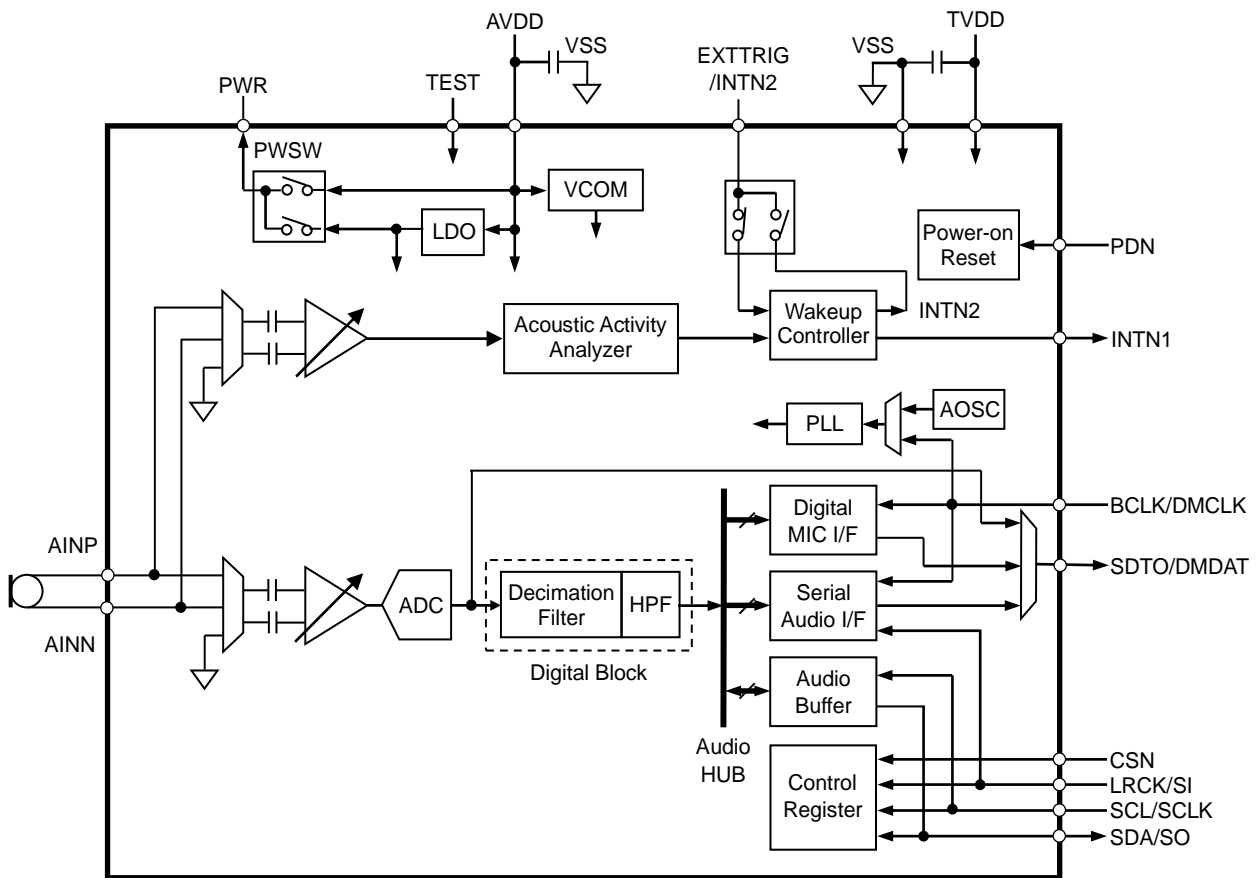
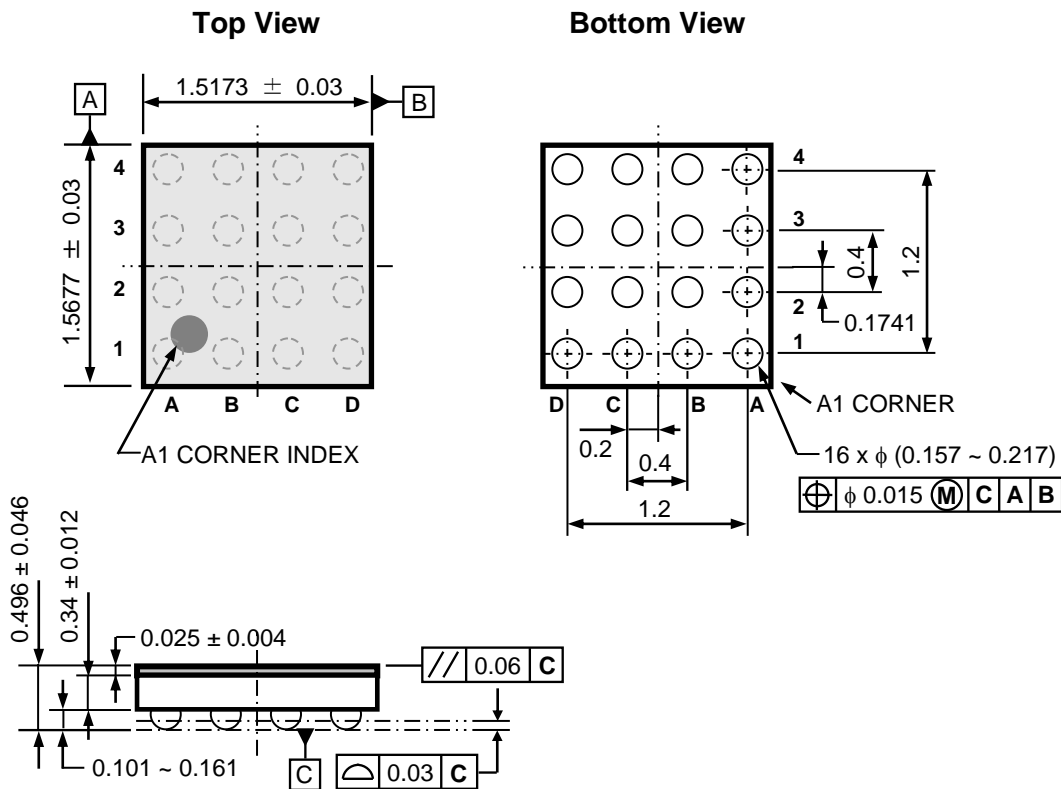

Figure 1. AK5707 Block Diagram

4. Package

11.1. Outline Dimensions

16-pin CSP (1.5173 x 1.5677 mm, 0.4mm pitch)



11.2. Material & Lead finish

Package molding compound: Epoxy, Halogen free
 Solder ball material: SnAgCu

11.3. Marking

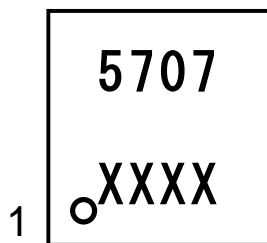

A
 XXXX: Date code (4 digits)
 Pin #A1 indication

IMPORTANT NOTICE

0. Asahi Kasei Microdevices Corporation (“AKM”) reserves the right to make changes to the information contained in this document without notice. When you consider any use or application of AKM product stipulated in this document (“Product”), please make inquiries the sales office of AKM or authorized distributors as to current status of the Products.
1. All information included in this document are provided only to illustrate the operation and application examples of AKM Products. AKM neither makes warranties or representations with respect to the accuracy or completeness of the information contained in this document nor grants any license to any intellectual property rights or any other rights of AKM or any third party with respect to the information in this document. You are fully responsible for use of such information contained in this document in your product design or applications. **AKM ASSUMES NO LIABILITY FOR ANY LOSSES INCURRED BY YOU OR THIRD PARTIES ARISING FROM THE USE OF SUCH INFORMATION IN YOUR PRODUCT DESIGN OR APPLICATIONS.**
2. The Product is neither intended nor warranted for use in equipment or systems that require extraordinarily high levels of quality and/or reliability and/or a malfunction or failure of which may cause loss of human life, bodily injury, serious property damage or serious public impact, including but not limited to, equipment used in nuclear facilities, equipment used in the aerospace industry, medical equipment, equipment used for automobiles, trains, ships and other transportation, traffic signaling equipment, equipment used to control combustions or explosions, safety devices, elevators and escalators, devices related to electric power, and equipment used in finance-related fields. Do not use Product for the above use unless specifically agreed by AKM in writing.
3. Though AKM works continually to improve the Product’s quality and reliability, you are responsible for complying with safety standards and for providing adequate designs and safeguards for your hardware, software and systems which minimize risk and avoid situations in which a malfunction or failure of the Product could cause loss of human life, bodily injury or damage to property, including data loss or corruption.
4. Do not use or otherwise make available the Product or related technology or any information contained in this document for any military purposes, including without limitation, for the design, development, use, stockpiling or manufacturing of nuclear, chemical, or biological weapons or missile technology products (mass destruction weapons). When exporting the Products or related technology or any information contained in this document, you should comply with the applicable export control laws and regulations and follow the procedures required by such laws and regulations. The Products and related technology may not be used for or incorporated into any products or systems whose manufacture, use, or sale is prohibited under any applicable domestic or foreign laws or regulations.
5. Please contact AKM sales representative for details as to environmental matters such as the RoHS compatibility of the Product. Please use the Product in compliance with all applicable laws and regulations that regulate the inclusion or use of controlled substances, including without limitation, the EU RoHS Directive. AKM assumes no liability for damages or losses occurring as a result of noncompliance with applicable laws and regulations.
6. Resale of the Product with provisions different from the statement and/or technical features set forth in this document shall immediately void any warranty granted by AKM for the Product and shall not create or extend in any manner whatsoever, any liability of AKM.
7. This document may not be reproduced or duplicated, in any form, in whole or in part, without prior written consent of AKM.

Mouser Electronics

Authorized Distributor

Click to View Pricing, Inventory, Delivery & Lifecycle Information:

[Asahi Kasei Microdevices:](#)

[AK5707ECB](#)