

SMD ▪ MID Power LED

67-23ST/KKX-5MXXXXXX96Z10/2T



Features

- PLCC-2 package
- Top view white LED
- High luminous intensity output
- Wide viewing angle
- Pb-free
- ANSI Binning
- The product itself will remain within RoHS compliant version.
- Compliance with EU REACH.
- Compliance Halogen Free .(Br<900ppm,Cl<900ppm,Br+Cl<1500ppm)

Description

The Everlight 67-23ST package has high efficacy, high CRI, high power consumption, wide viewing angle and a compact form factor. These features make this package an ideal LED for all lighting applications.

Applications

- General lighting
- Decorative and Entertainment Lighting
- Indicators
- Illumination
- Switch lights

Product Number Explanation

67-23ST/ K KX – 5M XX XXX XX Z10 / 2 T

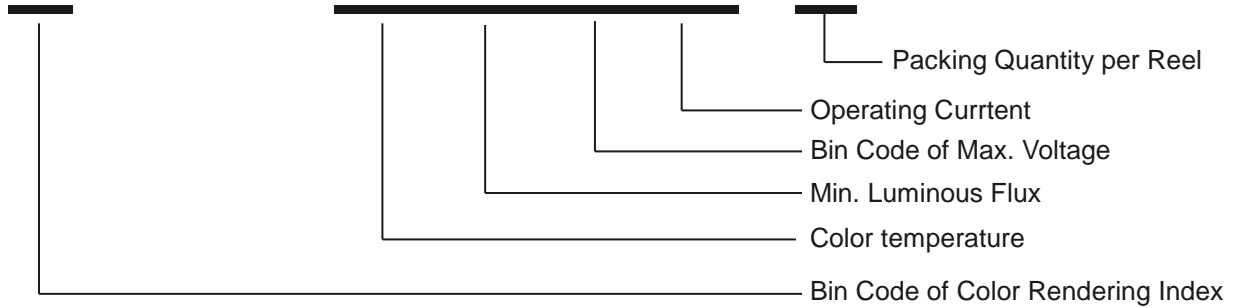

Table of Color Rendering Index

Symbol	Description
M	CRI(Min.) : 60
N	CRI(Min.) : 65
L	CRI(Min.) : 70
Q	CRI(Min.) : 75
K	CRI(Min.) : 80
P	CRI(Min.) : 85
H	CRI(Min.) : 90
J	CRI(Typ.) : 80

Note:
Tolerance of Color Rendering Index: ± 2

Table of Forward Current Index

Symbol	Description
Z10	IF:100mA

Table of Forward Voltage Index

Symbol	Description
96	9.6V max

Example:
67-23ST/KKX-5M4016096Z10/2T

CRI	80(min.)
CCT	4000K
Flux	160lm min
V_F	9.6V max
I_F	100mA

Mass Production List

Series For 4000K 155Lm

Product	CRI Min. (1)	CCT(K)	Φ(lm) Min. (2)	Φ(V _F) Max. (3)
67-23ST/KKX-5M2714096Z10/2T	80	2700K	140	9.6
67-23ST/KKX-5M3014596Z10/2T	80	3000K	145	9.6
67-23ST/KKX-5M3515096Z10/2T	80	3500K	150	9.6
67-23ST/KKX-5M4015596Z10/2T	80	4000K	155	9.6
67-23ST/KKX-5M5015596Z10/2T	80	5000K	155	9.6
67-23ST/KKX-5M5715596Z10/2T	80	5700K	155	9.6
67-23ST/KKX-5M6015596Z10/2T	80	6000K	155	9.6
67-23ST/KKX-5M6515096Z10/2T	80	6500K	150	9.6

Series For 4000K 160Lm

Product	CRI Min. (1)	CCT(K)	Φ(lm) Min. (2)	Φ(V _F) Max. (3)
67-23ST/KKX-5M2714596Z10/2T	80	2700K	145	9.6
67-23ST/KKX-5M3015096Z10/2T	80	3000K	150	9.6
67-23ST/KKX-5M3515596Z10/2T	80	3500K	155	9.6
67-23ST/KKX-5M4016096Z10/2T	80	4000K	160	9.6
67-23ST/KKX-5M5016096Z10/2T	80	5000K	160	9.6
67-23ST/KKX-5M5716096Z10/2T	80	5700K	160	9.6
67-23ST/KKX-5M6016096Z10/2T	80	6000K	160	9.6
67-23ST/KKX-5M6515596Z10/2T	80	6500K	155	9.6

Series For 4000K 165Lm

Product	CRI Min. (1)	CCT(K)	Φ (lm) Min. (2)	Φ (V _F) Max. (3)
67-23ST/KKX-5M2715096Z10/2T	80	2700K	150	9.6
67-23ST/KKX-5M3015596Z10/2T	80	3000K	155	9.6
67-23ST/KKX-5M3516096Z10/2T	80	3500K	160	9.6
67-23ST/KKX-5M4016596Z10/2T	80	4000K	165	9.6
67-23ST/KKX-5M5016596Z10/2T	80	5000K	165	9.6
67-23ST/KKX-5M5716596Z10/2T	80	5700K	165	9.6
67-23ST/KKX-5M6016596Z10/2T	80	6000K	165	9.6
67-23ST/KKX-5M6516096Z10/2T	80	6500K	160	9.6

Notes:

1. Tolerance of Color Rendering Index: ± 2
2. Tolerance of Luminous flux: $\pm 11\%$.
3. Tolerance of Forward Voltage: $\pm 0.1V$.

EVERLIGHT

Device Selection Guide

Chip Materials	Emitted Color	Resin Color
InGaN	Cool White Neutral White Warm White	Water Clear

Absolute Maximum Ratings (T_{Soldering}=25°C)

Parameter	Symbol	Rating	Unit
Forward Current	I _F	120	mA
Peak Forward Current (Duty 1/10 @10ms)	I _{FP}	200	mA
Power Dissipation	P _d	1152	mW
Operating Temperature	T _{opr}	-40 ~ +85	°C
Storage Temperature	T _{stg}	-40 ~ +100	°C
Thermal Resistance (Junction / Soldering point)	R _{th J-S}	17	°C/W
Junction Temperature	T _j	115	°C
Soldering Temperature	T _{sol}	Reflow Soldering : 260 °C for 10 sec. Hand Soldering : 350 °C for 3 sec.	

Note:

The products are sensitive to static electricity and must be carefully taken when handling products

Electro-Optical Characteristics (T_{Soldering}=25°C)

Parameter	Symbol	Min.	Typ.	Max.	Unit	Condition
Luminous Flux ⁽¹⁾	Φ	140	-----	----	lm	I _F =100mA
Forward Voltage ⁽²⁾	V _F	8.4	-----	9.6	V	I _F =100mA
Color Rendering Index ⁽³⁾	R _a	80	----	-----		I _F =100mA
	R ₉	0	----	----		I _F =100mA
Viewing Angle	2θ _{1/2}	-----	120	-----	deg	I _F =100mA
Reverse Current	I _R	-----	-----	50	μA	V _R =10V

Notes:

1. Tolerance of Luminous flux: ±11%.
2. Tolerance of Forward Voltage: ±0.1V.
3. Tolerance of Color Rendering Index: ±2

Bin Range of Luminous Flux

Series For 4000K 155Lm

Bin Code	Min.	Max.	Unit	Condition
140L5	140	145	lm	I _F =100mA
145L5	145	150		
150L5	150	155		
155L5	155	160		
160L5	160	165		
165L5	165	170		
170L5	170	175		

Series For 4000K 160Lm

Bin Code	Min.	Max.	Unit	Condition
145L5	145	150	lm	I _F =100mA
150L5	150	155		
155L5	155	160		
160L5	160	165		
165L5	165	170		
170L5	170	175		
175L5	175	180		

Series For 4000K 165Lm

Bin Code	Min.	Max.	Unit	Condition
150L5	150	155	lm	I _F =100mA
155L5	155	160		
160L5	160	165		
165L5	165	170		
170L5	170	175		
175L5	175	180		
180L5	180	185		

Note:
 Tolerance of Luminous flux: ±11%.

Bin Range of Forward Voltage

Group	Bin Code	Min.	Max.	Unit	Condition
8496	84C	8.4	8.7	V	I _F =100mA
	87C	8.7	9.0		
	90C	9.0	9.3		
	93C	9.3	9.6		

Note:

Tolerance of Forward Voltage: $\pm 0.1V$.

EVERLIGHT

Bin Code of Macadam 5 step

Step	CCT	Bin Code	Cx	Cy	a	b	theta
5	2700K	27-M5	0.4583	0.4104	0.0135	0.007	49.7
	3000K	30-M5	0.4345	0.4033	0.0139	0.0068	50.22
	3500K	35-M5	0.408	0.3919	0.01545	0.0069	51
	4000K	40-M5	0.3827	0.3803	0.01565	0.0067	54.8
	5000K	50-M5	0.3451	0.3559	0.0137	0.0059	64.12
	5700K	57-M5	0.3293	0.3423	0.01245	0.00535	66.51
	6000K	60-M5	0.3213	0.3357	0.01115	0.00475	64.57
	6500K	65-M5	0.3131	0.329	0.01115	0.00475	64.57

The C.I.E. 1931 Chromaticity Diagram

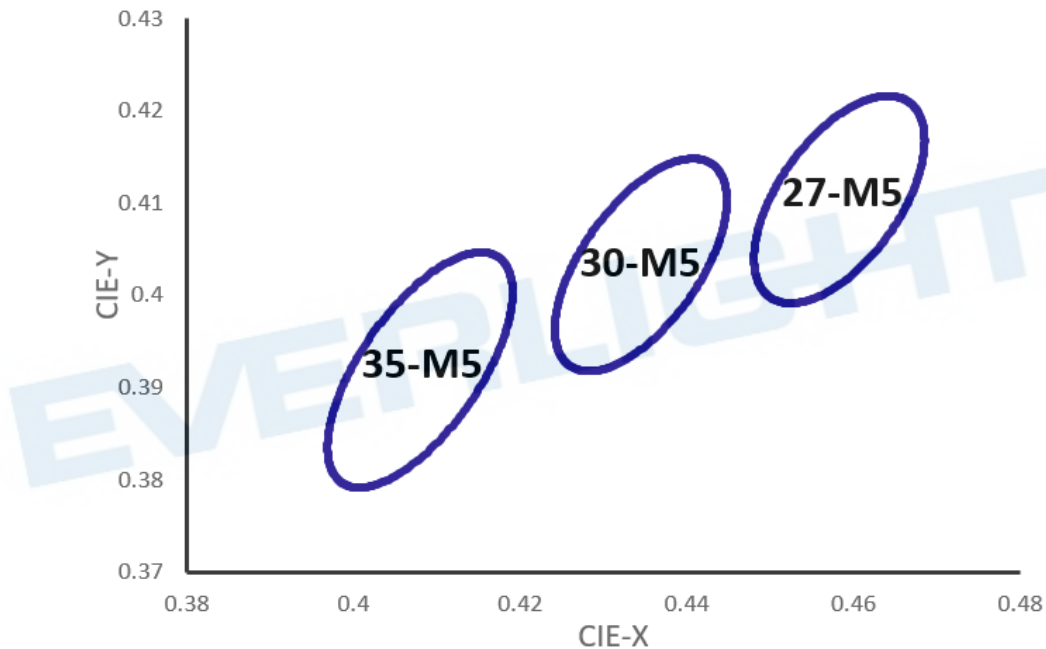

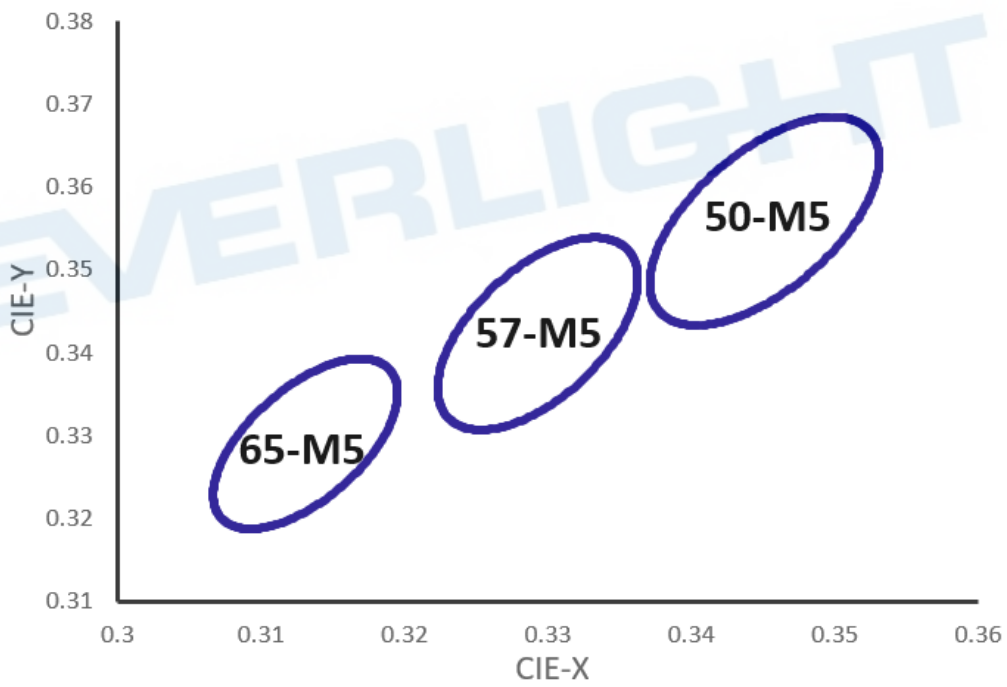
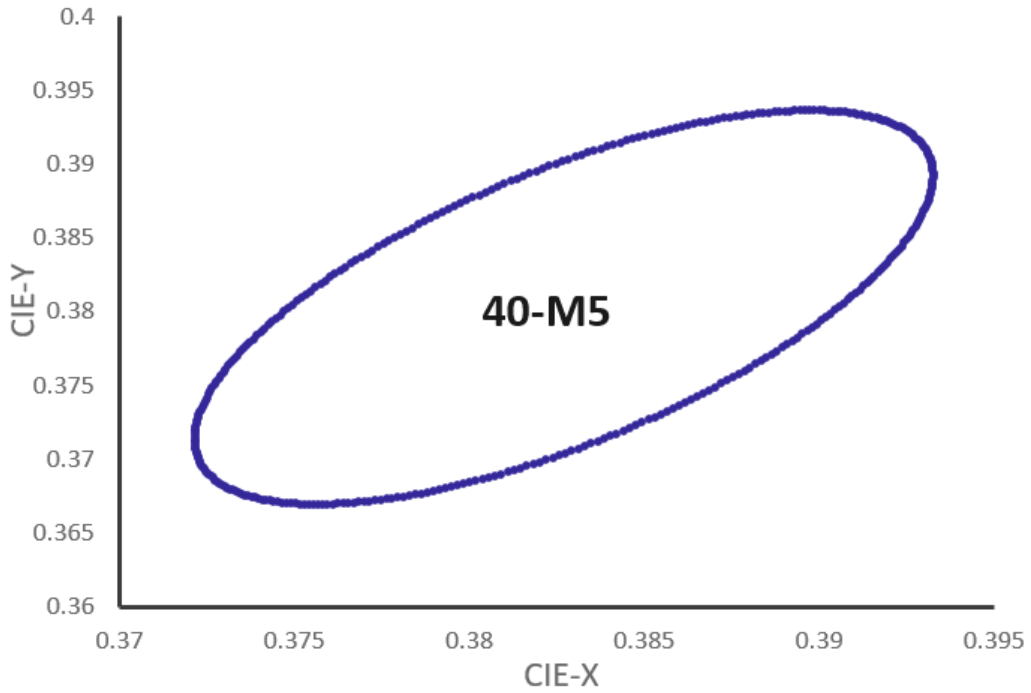

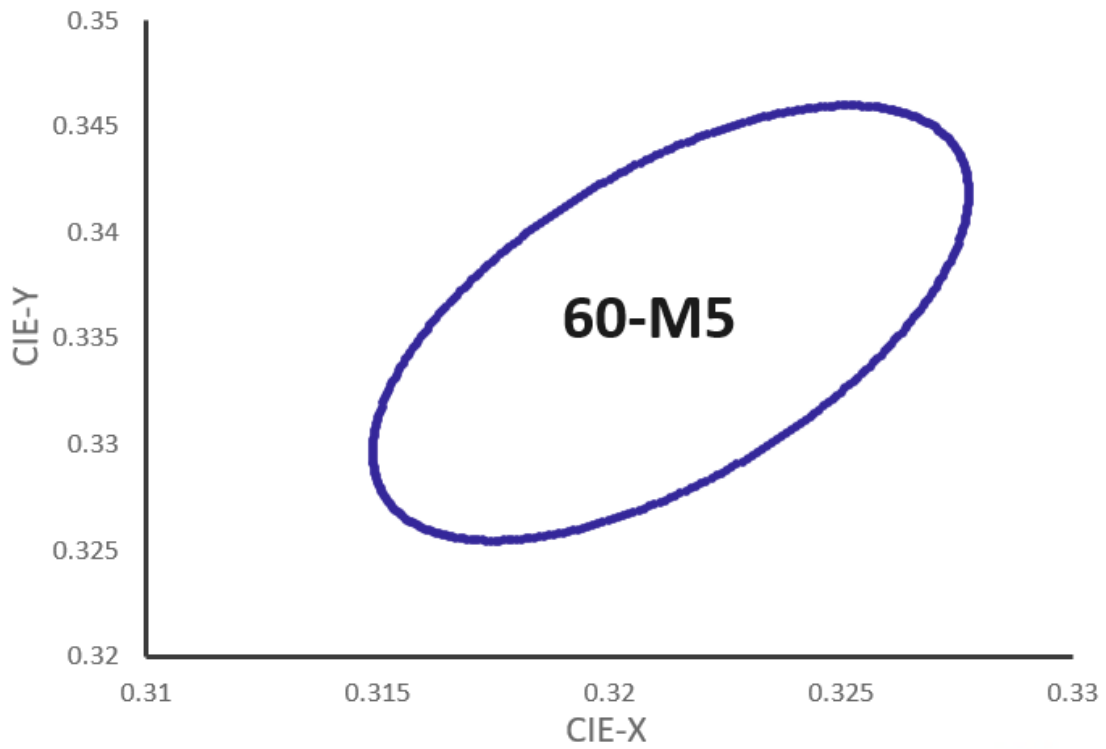

Notes:

1. The value is based on driving current by 100mA.
2. Tolerance of Chromaticity Coordinates: ± 0.01 .

EVERLIGHT

Spectrum Distribution

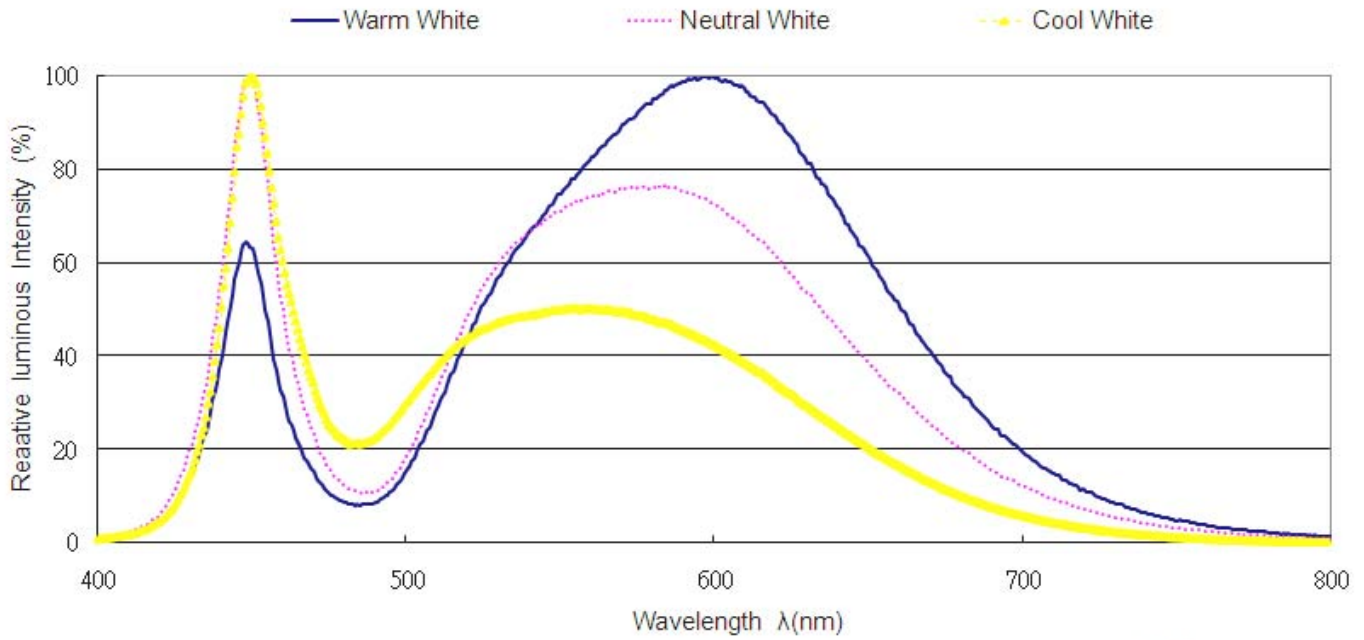

Typical Electro-Optical Characteristics Curves

Fig.1 – Forward Voltage Shift vs. Junction Temperature

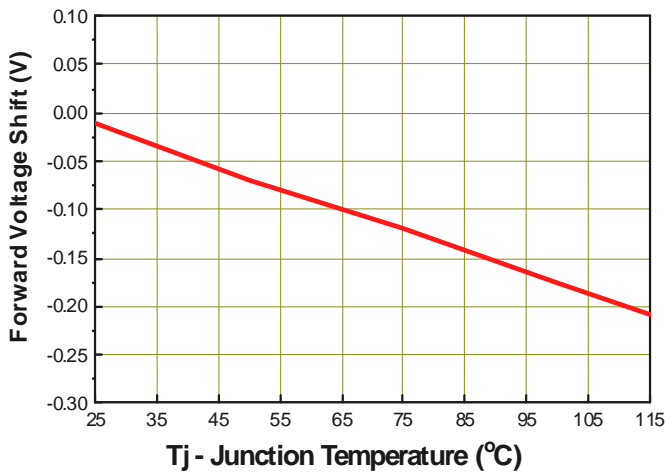
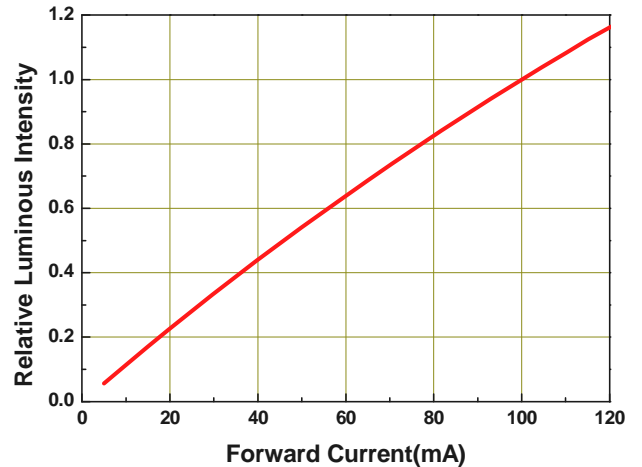

Fig.2 - Relative Luminous Intensity vs. Forward Current



Typical Electro-Optical Characteristics Curves

Fig.3 - Relative Luminous Intensity vs. Junction Temperature

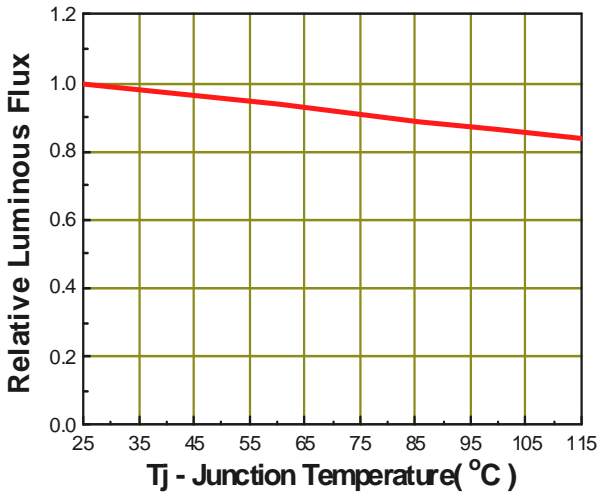

Fig.4 - Forward Current vs. Forward Voltage

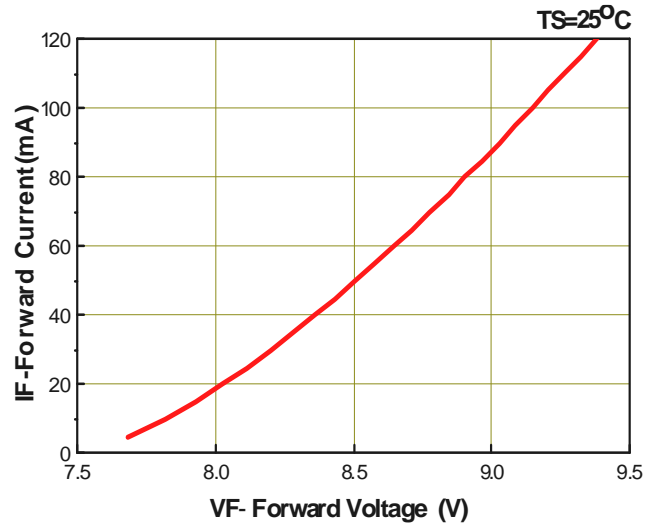

Fig.5 – Max. Driving Forward Current vs. Soldering Temperature

$R_{th\ j-s}=17\ ^\circ\text{C/W}$

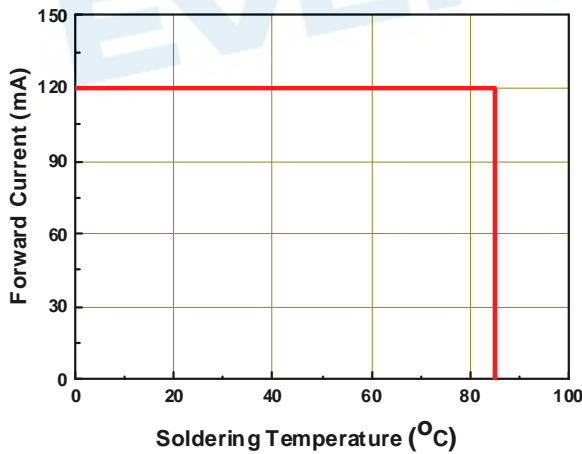
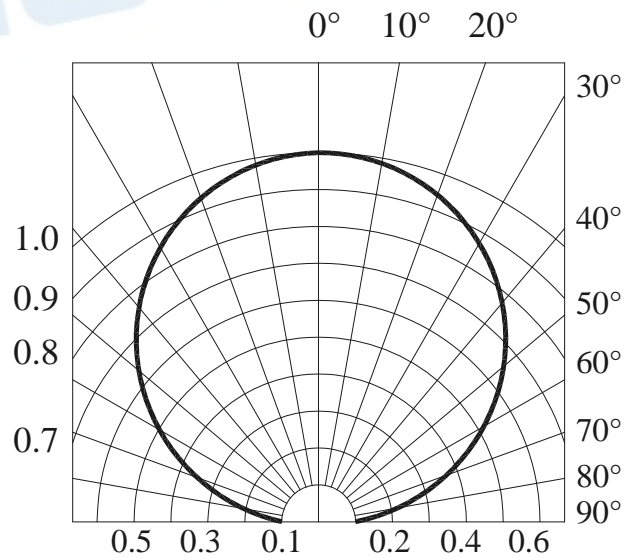
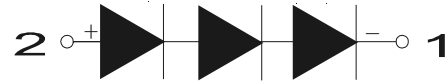
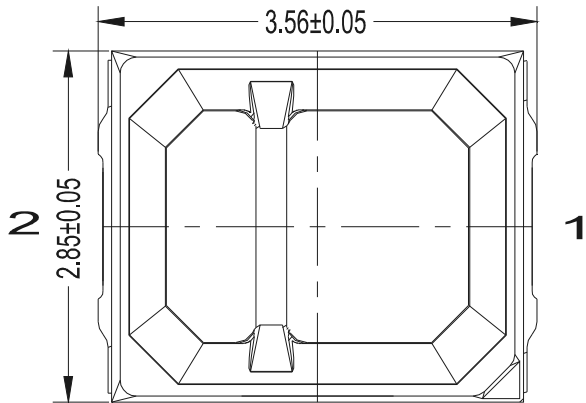

Fig.6 – Radiation Diagram



Package Dimension



Polarity

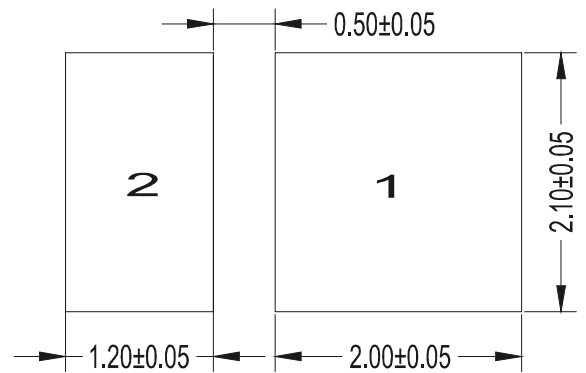
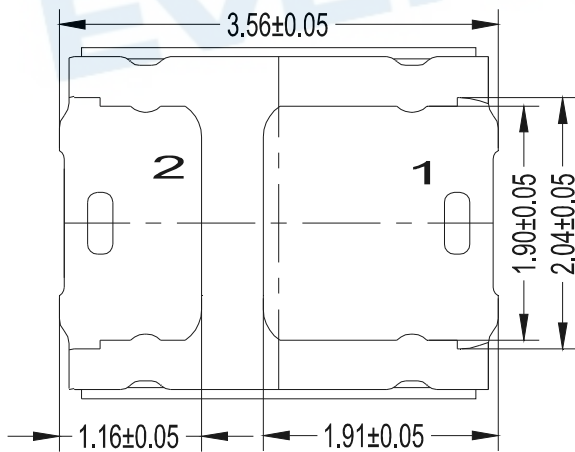
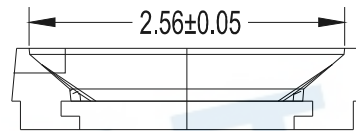
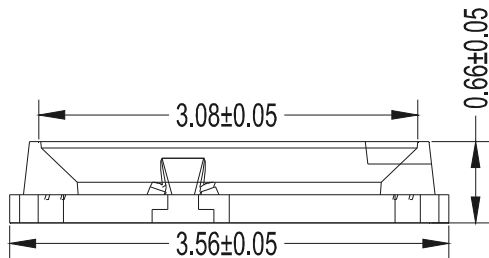

Soldering patterns

Note:
 Tolerance unless mentioned is ± 0.15 mm; Unit = mm

Moisture Resistant Packing Materials

Label Explanation

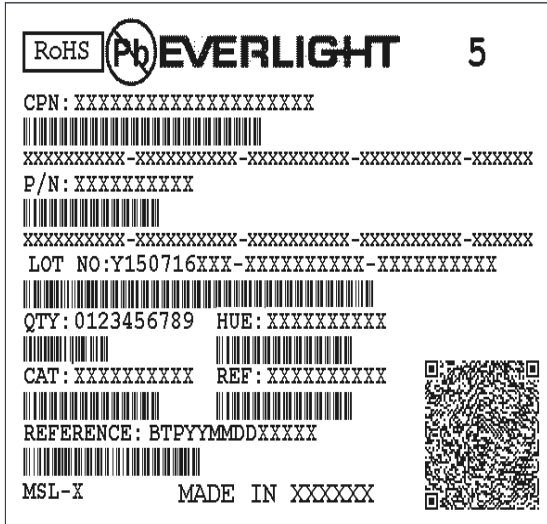

- CPN: Customer's Product Number
- P/N: Product Number
- QTY: Packing Quantity
- CAT: Luminous Intensity Rank
- HUE: Dom. Wavelength Rank
- REF: Forward Voltage Rank
- LOT No: Lot Number

Reel Dimensions

1.Carrier Tape Dimensions:

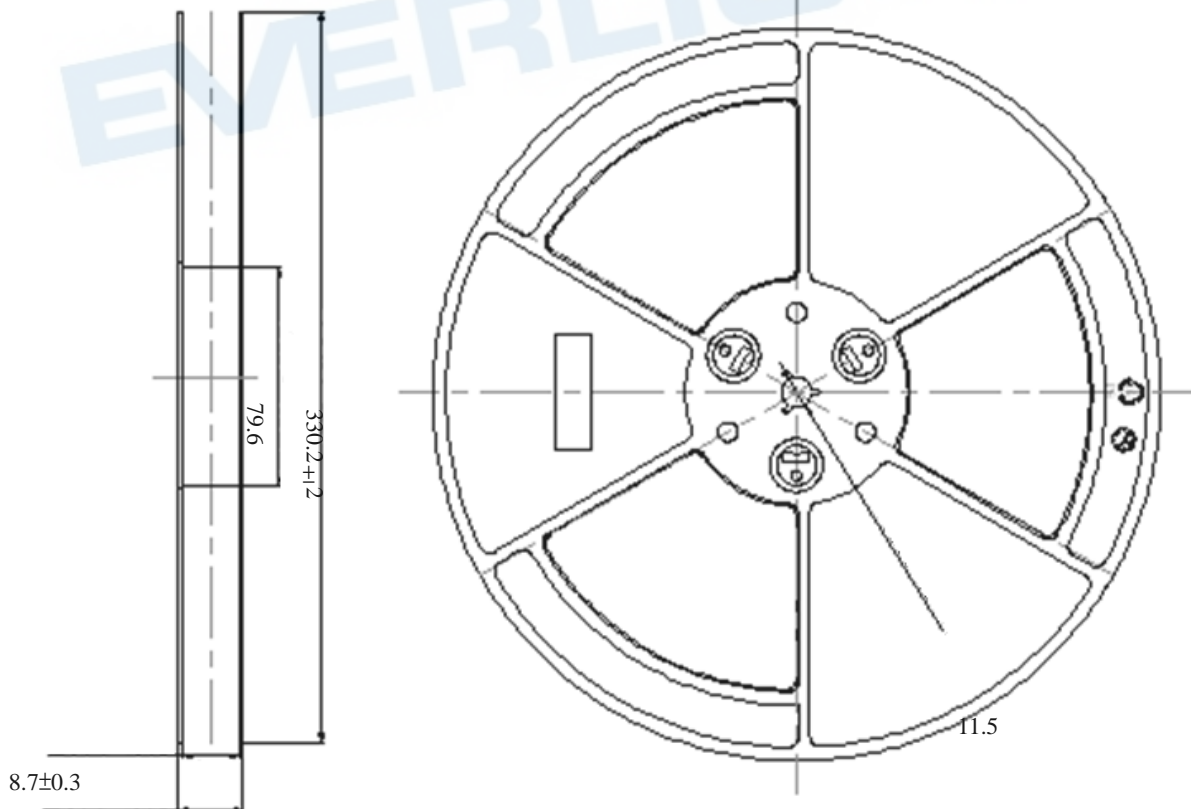

1-1. Loaded Quantity 16000 pcs Per Reel

2.Carrier Tape Dimensions:

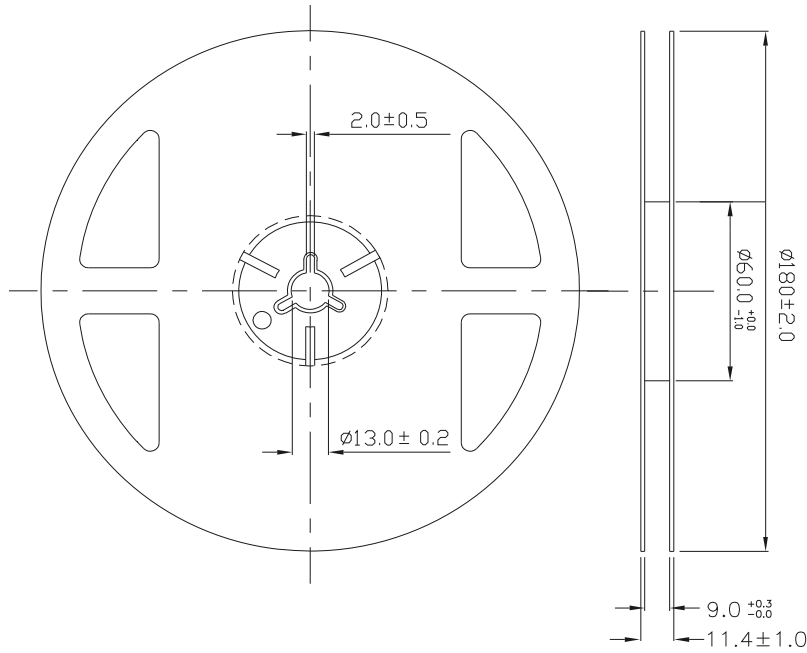

2-1.Loaded Quantity 500/1000/1500/2000/2500/3000/3500/4000 pcs Per Reel

Note:
Tolerances unless mentioned ± 0.1 mm. Unit = mm

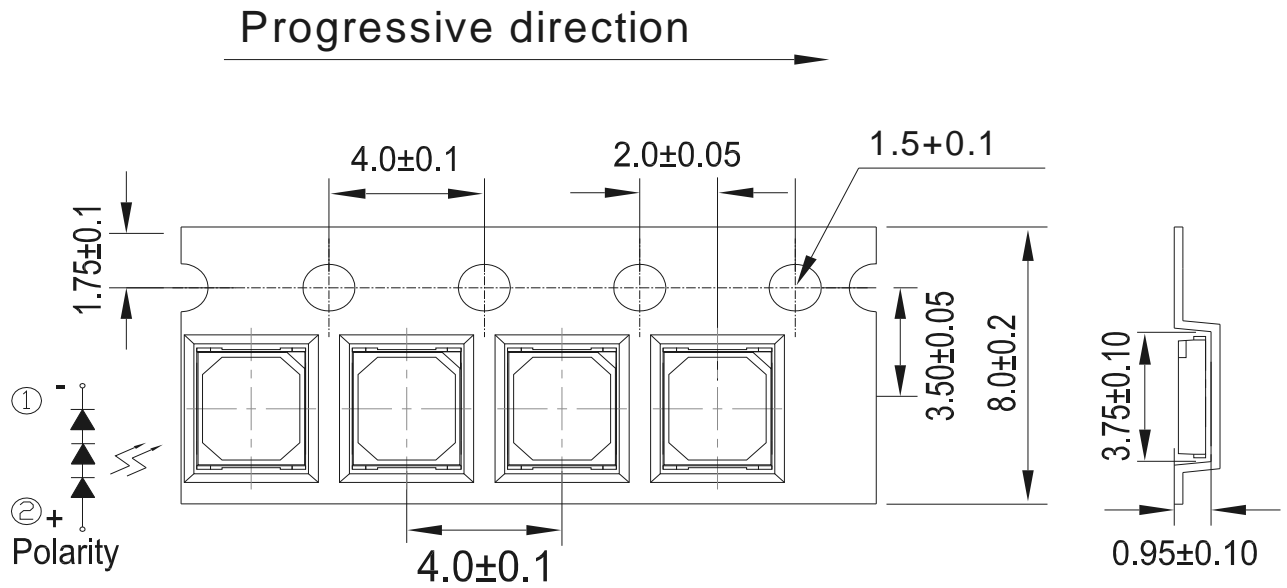

Note:
 1. Tolerance unless mentioned is ± 0.1 mm; Unit = mm

Moisture Resistant Packing Process

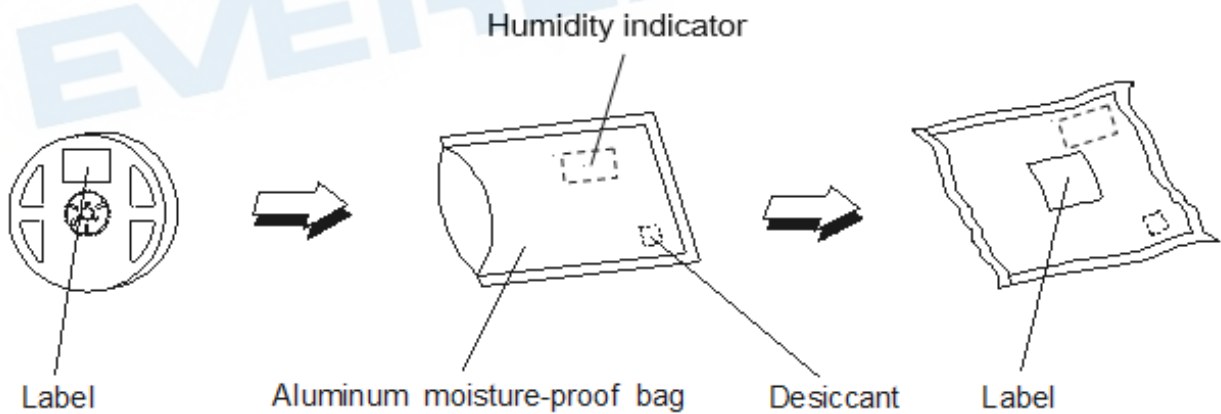

Reliability Test Items and Conditions

The reliability of products shall be satisfied with items listed below.
 Confidence level : 90%
 LTPD : 10%

No.	Items	Test Condition	Test Hours/Cycles	Sample Size	Ac/Re
1	Resistance to Solder Heat	Temp. : 260°C/10sec.	3 Times.	8 PCS.	0/1
2	Temperature Cycle	-40°C~100°C / Dwell time 30min	200 Cycles	8 PCS.	0/1
3	High Temperature/Humidity Life	Ta=85°C,85%RH, I _F = 120mA	1000 Hrs.	8 PCS.	0/1
4	Low Temperature Life	Ta=-40°C, I _F = 120 mA	1000 Hrs.	8 PCS.	0/1
5	High Temperature Life	Ta=60°C, I _F =120 mA	3000 Hrs.	8 PCS.	0/1
6	High Temperature Life	Ta=85°C, I _F =120 mA	3000 Hrs.	8 PCS.	0/1
7	Pulse	ON 30ms / OFF 2500ms	30000 CYCLES	8 PCS.	0/1
8	Thermal Shock	H : +100°C 20min ∩ 10 sec L : -40°C 20min	200 Cycles	8 PCS.	0/1
9	Power Temperature Cycle	H : +100°C 15min ∩ 5 min L : -40°C 15min I _F = 80 mA	200 Cycles	8 PCS.	0/1

Precautions for Use

1. Over-current-proof

Customer must apply resistors for protection; otherwise slight voltage shift will cause big current change (Burn out will happen).

2. Storage

2.1 Do not open moisture proof bag before the products are ready to use.

2.2 Before opening the package: The LEDs should be kept at 30°C or less and 90%RH or less.

2.3 After opening the package: The LED's floor life is 168 Hrs under 30°C or less and 60% RH or less. If unused LEDs remain, it should be stored in moisture proof packages.

2.4 If the moisture absorbent material (silica gel) has faded away or the LEDs have exceeded the storage time, baking treatment should be performed using the following conditions.

Baking treatment: 60±5°C for 24 hours.

3. Soldering Condition

3.1 Pb-free solder temperature profile

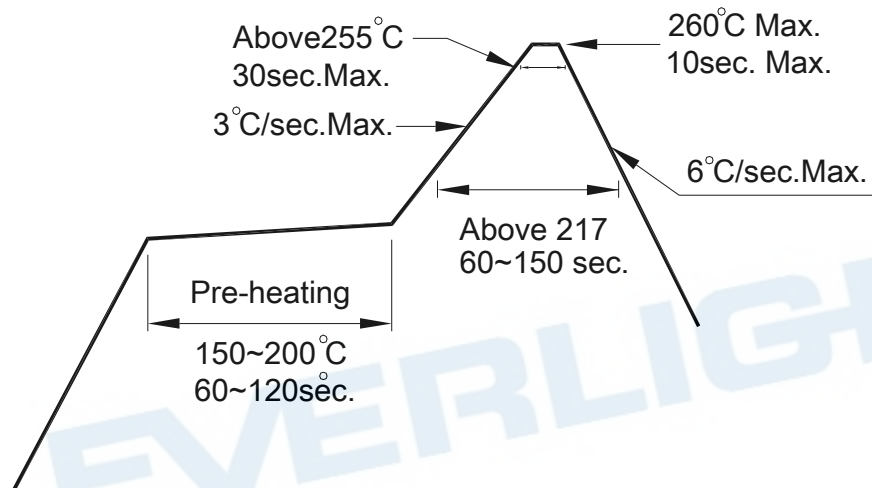

3.2 Reflow soldering should not be done more than two times.

3.3 When soldering, do not put stress on the LEDs during heating.

3.4 After soldering, do not warp the circuit board.

4. Soldering Iron

Each terminal is to go to the tip of soldering iron temperature less than 350°C for 3 seconds within once in less than the soldering iron capacity 25W. Leave two seconds and more intervals, and do soldering of each terminal. Be careful because the damage of the product is often started at the time of the hand solder.

5. Repairing

Repair should not be done after the LEDs have been soldered. When repairing is unavoidable, a double-head soldering iron should be used (as below figure). It should be confirmed beforehand whether the characteristics of the LEDs will or will not be damaged by repairing.

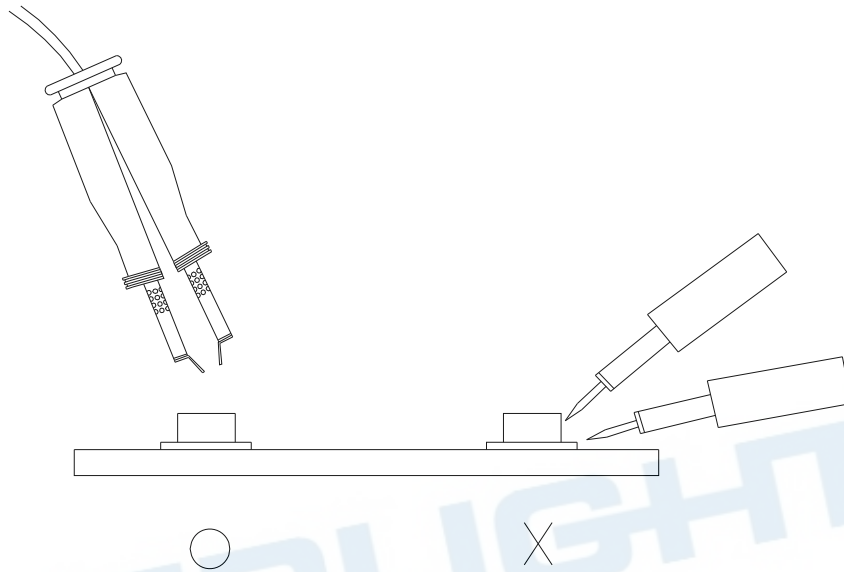

DISCLAIMER

1. EVERLIGHT reserves the right(s) on the adjustment of product material mix for the specification.
2. The product meets EVERLIGHT published specification for a period of twelve (12) months from date of shipment.
3. The graphs shown in this datasheet are representing typical data only and do not show guaranteed values.
4. When using this product, please observe the absolute maximum ratings and the instructions for using outlined in these specification sheets. EVERLIGHT assumes no responsibility for any damage resulting from the use of the product which does not comply with the absolute maximum ratings and the instructions included in these specification sheets.
5. These specification sheets include materials protected under copyright of EVERLIGHT. Reproduction in any form is prohibited without obtaining EVERLIGHT's prior consent.
6. This product is not intended to be used for military, aircraft, automotive, medical,

EVERLIGHT

Mouser Electronics

Authorized Distributor

Click to View Pricing, Inventory, Delivery & Lifecycle Information:

[Everlight:](#)

[67-23ST/KKX-5M4016596Z10/2T](#)